

kaise

BATTERY CHECKER

Instruction Manual

SK-8535



KAISE CORPORATION

INTRODUCTION

Thank you for purchasing "BATTERY CHECKER SK-8535". To obtain the maximum performance of this instrument, read this Instruction Manual carefully, and take safe measurement.

CONTENTS

SAFETY PRECAUTIONS	1 - 3
OPERATING PRECAUTIONS	4
FEATURES	5
UNPACKING AND INSPECTION	6
NAME ILLUSTRATION	7 - 8
SPECIFICATIONS	
1. General Specifications	9
2. Measurement Specifications	9
BEFORE USE	
1. Technical Words	10 - 11
2. Language / Date & Time Settings	11
3. Others	11
MEASUREMENT PROCEDURES	
1. Battery Test	12 - 19
2. Battery System Test	20 - 22
3. Print out	23 - 25
4. Test Result Saving	26 - 27
5. View the Saved Data	28
6. Delete the Saved Data	29
7. Connecting to PC	30 - 31
8. Setting of Date and Time	32
9. Setting of Language	33
10. Contrast Adjustment	33
11. Temperature Setting	34
12. CCA Value List for Battery Manufacturers and Their Models	35 - 36
MAINTENANCE	
1. Printing Paper Setup	37 - 38
2. Formatting of Removable Disk	39 - 40
3. Periodical Check and Calibration	40
4. Software Version Update	40
5. Others	40
TROUBLE SHOOTING & REPAIR	41

SAFETY PRECAUTIONS (strict observance is required)

This instruction manual contains the important contents to prevent harm to user or others and damage of property, and to use the instrument safely and correctly.

Read this manual carefully and obey the contents after having understand the following terms and symbols.

- The points where the following symbols are attached in this manual describe the degree of harm and damage that would be caused by incorrect usage due to neglect of this description.



WARNING

This symbol in this manual advises the user of an electrical shock hazard that could result in serious injury or even death.



CAUTION

This symbol in this manual advises the user of an electrical shock hazard that could cause injury or material damages.

- The points where the following symbols are attached in this manual describe the matters which must obey in accordance with the each meanings. (following symbols are some examples.)



This symbol shows the warnings and cautions.



This symbol shows the prohibited matters.



This symbol shows the matters that is forced to do.

SAFETY PRECAUTIONS (strict observance is required)

WARNING

Take the measurement under well-ventilated environment.

The hydrogen gas which stayed around battery catches fire from the spark that occurred when connecting the Battery Clips and might explode.



Make sure that the shift lever is set to "Parking" position (set to "Neutral" for stick shift car).

The car runs accidentally and could cause unexpected accident, electric shock, fire or damage to the instrument or the car.



Make sure that the parking brake is applied.

The car runs accidentally and could cause unexpected accident, electric shock, fire or damage to the instrument or the car.



Keep the instrument away from babies or children.

Important to prevent any accident, injury, or electric shock hazard.



Do not use this instrument with the hands or Battery Clips wetting.

Accident, electric shock, fire, or damage to the instrument or the car may occur.



Do not take the measurement around inflammables such as gasoline or oil.

Fire or explosion may occur.



Do not take the measurement for the battery which does not have enough battery fluid.

It causes combustion and the explosion of the battery.



Do not drive the car keeping the instrument connected.

Accident, electric shock, fire, or damage to the instrument or the car may occur.



Do not work in the dark place.

Accident, electric shock, fire, or damage to the instrument or the car may occur.



Do not get the instrument wet.

Fire or electric shock may occur.



Do not use the faulty instrument that can recognize such as display trouble, switch failure.

Stop using the instrument immediately and consult with your local dealer. Using the faulty instrument may cause the unexpected accident, fire, or electric shock.



Do not touch the USB port with finger or insert the foreign objects in the USB port.

Unexpected accident, electric shock, fire, or damage to the instrument may occur.



Do not place this instrument in any place where it will be subjected to direct sunlight, high temperatures or the inside of the sun-heated cars.

Fire, electric shock or damage to the instrument may occur.



Do not touch the heated part of the engine such as exhausting parts.

Important to prevent burn injury.



SAFETY PRECAUTIONS (strict observance is required)

WARNING

Be careful about your hands, gloves and clothes not to be caught in the engine belt or cooling fan.

Important to prevent injury.



Do not use the instrument if it is in the abnormal condition.

Stop using the instrument immediately and consult with your local dealer when recognizing smoke, strange smell, or abnormal noise.

Using the faulty instrument may cause the unexpected accident, fire, or electric shock.



Do not attempt to disassemble or modify the instrument.

Fire, electric shock, or damage to the instrument may occur.



Do not use the cables with which coating were damaged.

Fire or electric shock may occur.



CAUTION

Be careful not to get the battery fluid into eyes or not to attach it to skin and clothes.

Loss of eyesight or injury may occur. If it gets into eyes, rinse immediately and submit to medical treatment.



Be careful not to jam the fingers in the Battery Clip.

It causes injury.



Be careful about the instrument or the cables not to be caught in the engine belt or cooling fan.

Short circuit or wire breaking may occur that could cause unexpected accident, electric shock, or damage to the instrument or the car.



Be careful about the instrument or the cables not to touch the heated part of the engine such as exhausting parts.

Important to prevent any accident, or damage to the instrument or the car.



Connect the Battery Clips to the battery with the correct polarity.

Reverse connection causes damage to the instrument.



When testing the battery on vehicle, take the measurement after stopping the engine and turning off the power supply of all in-vehicle apparatuses.

It causes injury or damage to the instrument.



Disconnect this instrument from battery soon after finishing the test.

It causes consumption of the battery and the ignition.



Do not hit, thrust and make scratch on the LCD display part.

It causes trouble or damage to the LCD.



Do not use the other USB cable except the supplied one.

Damage to the instrument or PC may occur.



OPERATING PRECAUTIONS

- Do not apply the engine oil to the metal part of the Battery Clips or USB Plug to prevent contact failure.
- Do not apply engine oil, gasoline, antifreeze or battery fluid to the instrument to prevent any damage on its surface.
- Do not polish the case with the fluid that contains alcohol to prevent the cracking.
- Use this instrument under the environment of -10°C to 50°C, 80%RH or less to obtain the accurate measurement. (Printer is operating at 0°C to 50°C)
- Cables which coating are heat damaged might cause the short circuit. Do not use them and replace into the new ones.
- Disconnect this instrument from battery soon after finishing the test to prevent trouble of this instrument and running out of battery power.
- Do not touch the inside of the printer with finger to prevent trouble of this instrument.
- Do not put serious pressure on Printer Lever or Printer Cover to prevent trouble or damage to this instrument.
- If Date and Time are not able to set, built-in battery for backup is exhausted. Ask KAISE AUTHORIZED SERVICE AGENCY through your local dealer for repair service.
- Keep this instrument in supplied Carrying Case to avoid malfunction of the printer trouble by dust penetration.

Cautions for Handling

- Do not apply mechanical shock.
The shock such as dropping or beating might damage the instrument and may cause the trouble.
- Do not pull cables forcibly.
Pulling the cables forcibly, such as when removing the Battery Clips from the battery or USB Plugs from USB Port, may cause trouble such as the breaking of wire.

Cautions for Safekeeping

- Keep away the instrument from the following place.
 - Dusty area
 - The place where has the water splash
 - The place where applies the hard shock
 - -20°C or less, 60°C or more, 70%RH or more
 - The place where has the condensation
 - The place where is exposed to direct sunlight

FEATURES

■ SK-8535 can test State of Charge (SOC), State of Health (SOH), Start Performance and Charging System of the car battery.

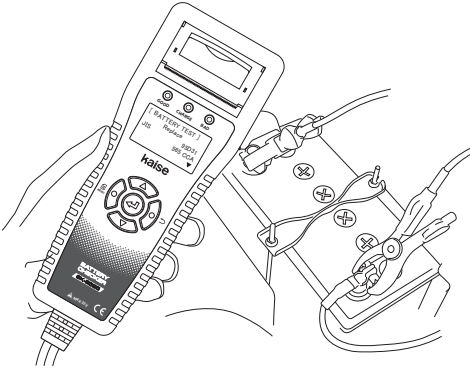

■ Auxiliary battery for hybrid car is testable.

■ Portable instrument that can operate with one hand.

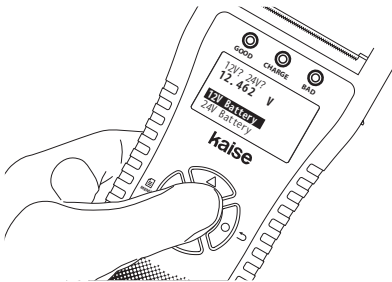

■ Capable of saving the test results up to 99 data. Moreover, the test data can edit on PC as text data by using the supplied USB cable.

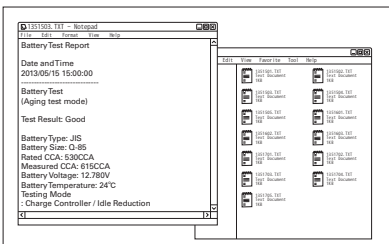

■ Batteries for the vehicle equipped with charge control system or idle reduction system are testable.

■ Test result can be printed on site by built-in printer. Printing language is selectable from Japanese, English and Simplified Chinese.

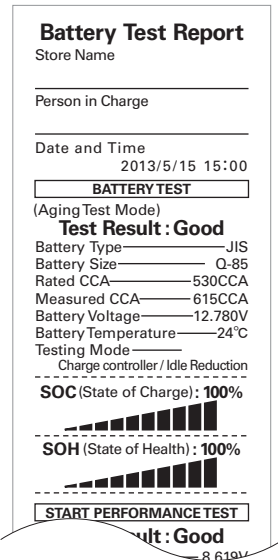

■ The software is upgradeable by connecting supplied USB cable with PC.(※)

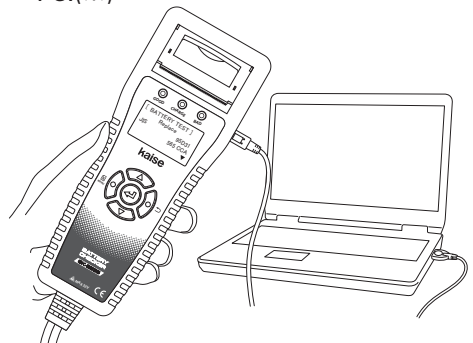

※PC with Internet access is necessary.

UNPACKING AND INSPECTION (Check before use)

Confirm if the following items are contained in the package in good condition.
If there are any damages or missing items, ask your local dealer for replacement.

① Battery Checker...1 pce.

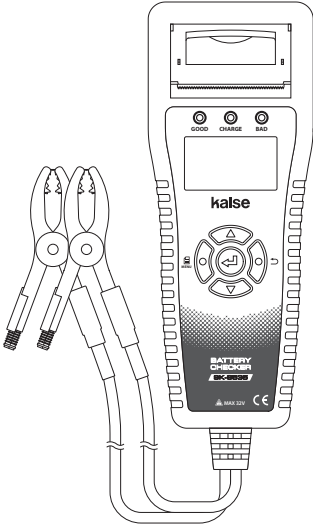

② USB Cable (937)...1 pce.



③ Printer Paper...2 rolls
(installed, and spare)

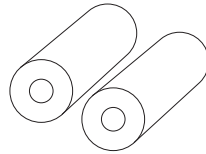

④ Carrying Case...1 pce.

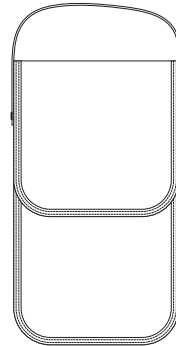

⑤ Instruction Manual...1 pce.

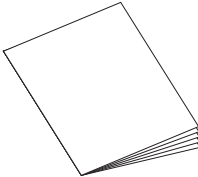

※The following desiccant is enclosed in the package for maintenance of quality. Throw it away after opening the package.



Available Printer Paper (10pcs per set)
Parts number : 851
(Paper width : approx. 57mm,
length : approx. 5.8m)

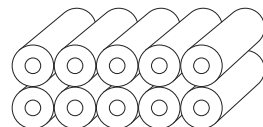

• Use above parts number when ordering.

NAME ILLUSTRATION

Front Side

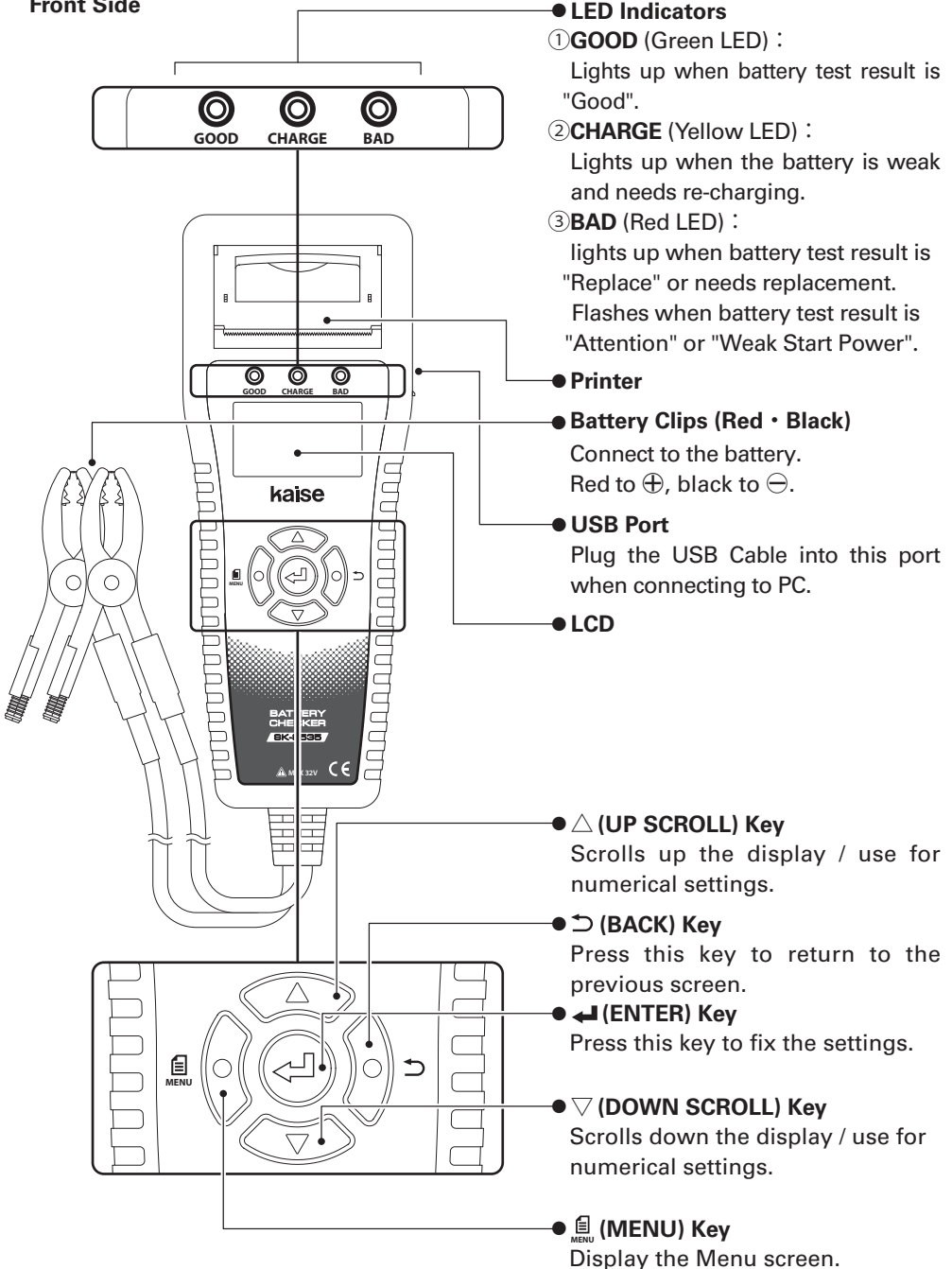

● LED Indicators

- ① **GOOD** (Green LED) :
Lights up when battery test result is "Good".
- ② **CHARGE** (Yellow LED) :
Lights up when the battery is weak and needs re-charging.
- ③ **BAD** (Red LED) :
lights up when battery test result is "Replace" or needs replacement.
Flashes when battery test result is "Attention" or "Weak Start Power".

● Printer

● Battery Clips (Red • Black)

Connect to the battery.
Red to ⊕, black to ⊖.

● USB Port

Plug the USB Cable into this port when connecting to PC.

● LCD

● △ (UP SCROLL) Key

Scrolls up the display / use for numerical settings.

● ↶ (BACK) Key

Press this key to return to the previous screen.

● ⏏ (ENTER) Key

Press this key to fix the settings.

● ▽ (DOWN SCROLL) Key

Scrolls down the display / use for numerical settings.

● ☰ (MENU) Key

Display the Menu screen.

NAME ILLUSTRATION

Rear Side

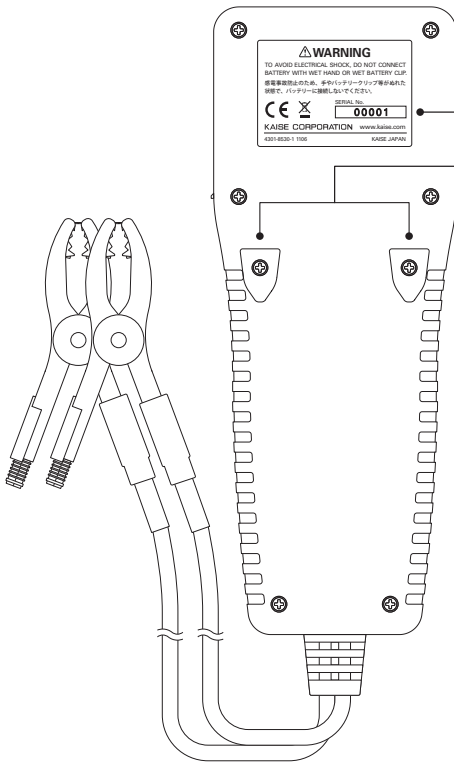

● Serial Number

● Battery Clip Holder

Clip Battery Clips here when not in use.

How to clip :

Open the battery clip widely and clip it to the holder in the plastic part of the clip. (Do not clip in the metal part)

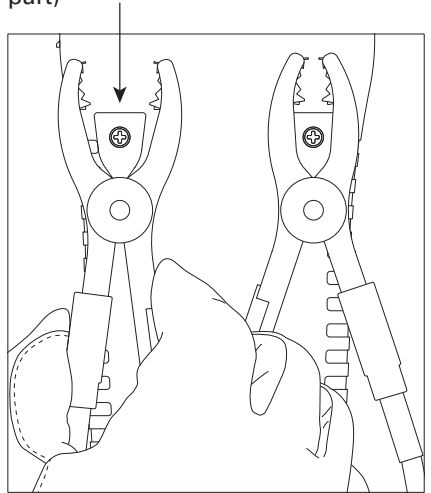

CAUTION

● Do not clip in the metal part of the Battery clip. To prevent any damages of the Battery Clip and Clip Holder.

SPECIFICATIONS

1. General Specifications

1. LCD	Dot presentation, 128×64dots
2. LANGUAGE	Japanese, English, Chinese (Default: English)
3. DISPLAY RATE OF VOLTAGE MEASUREMENT	1 time/second
4. LED INDICATION	Green : Lights up when battery test result is "Good" Yellow : Lights up when battery is weak and needs re-charging Red : Lights up when battery test result is "Replace" Flashes when battery test result is "Attention" or "Weak Start Power"
5. PRINTER	Built-in
6. BATTERY CABLE LENGTH	Approx.70cm (Clip and Bush are not included)
7. POWER SUPPLY	Testing battery or USB connection
8. TESTING VOLTAGE	DC8V to 32V (Testing battery), DC5V (USB Connection)
9. TESTABLE BATTERIES	12V lead batteries ※For 24V battery, only Start-up Performance Test or Charging System Test are possible.
10. TESTABLE BATTERY STANDARDS	JIS, DIN, EN, SAE, BCI, CCA and Industrial Rating
11. TESTABLE BATTERY PERFORMANCE	CCA : 100 to 1400, Industrial Rating : 1.0mΩ to 50.0mΩ
12. MEASURABLE TESTS	12V battery : Battery Test / Start Performance Test and Charging System Test 24V battery : Start Performance Test and Charging System Test
13. TEMPERATURE COEFFICIENT FOR VOLTAGE MEASUREMENT	Accuracy at 23°C±5°C×0.01/°C
14. DATA SAVING	Test results can be saved to the internal memory up to 99 data. ※The data can be sent to PC via USB connection
15. SOFTWARE UPDATE	From web site via USB connection
16. OPERATING TEMPERATURE & HUMIDITY	0°C to 50°C, less than 80%RH (in non-condensing)
17. STORAGE TEMPERATURE & HUMIDITY	-20°C to 60°C, less than 70%RH (in non-condensing)
18. SAFETY LEVEL	CE marking approved EN61326-1
19. DIMENSION	248mm(H)×96mm(W)×50mm(D) ※Cable and Bush are not included
20. WEIGHT	Approx. 550g ※Printer paper is not included

※Specification and appearance are subject to change without notice.

2. Measurement Specifications (23°C±5°C, <80%RH in non-condensing)

Battery Voltage

Range	Accuracy	Resolution	Maximum Input
16.000V	(8V to 16V) : ±0.15%±3dgt	1mV	Lower than 32V
32.000V	(16V~32V) : ±0.15%±3dgt		

※Overload indication : "Over voltage" is displayed.

Temperature

Range	Accuracy	Resolution	Maximum Input
-20°C to 60°C	±3°C	1°C	-20°C to 60°C

※Accuracy is applied when measuring after leaving under constant temperature more than an hour.

BEFORE USE

1. Technical Words

●What is CCA?

CCA stands for Cold Cranking Amperes. It is defined as the current a battery at 0°F (-18°C) can discharge for 30 seconds and maintain at least 7.2V (for JIS, SAE and BCI). And it is defined as the current a battery at 0°F (-18°C) can discharge for 10 seconds and maintain at least 7.5V (for EN and DIN). The battery which has the bigger CCA, the higher ability to start an engine, CCA is one of the criterion for selection of the battery.

CCA definition of various standards

Standards	CCA Definition	Countries
JIS	The current discharge at 0°F (-18°C) for 30 seconds and maintain at least 7.2V.	Japan
SAE		USA
BCI		USA
EN	The current discharge at 0°F (-18°C) for 10 seconds and maintain at least 7.5V.	EU
DIN		Germany

●What is SOH (State of Health)?

SOH is the health condition of the battery, the state is expressed in percentage (%).

Definition of SOH in this product :

SK-8535 defines SOH 23% as the threshold of the battery replacement recommendation.

Test result shows "Replacement is necessary" when measured SOH is 23% or less and test result of SOC is not "Charge/Retest".

※SOH(%) is calculated as the ratio of CCA standard value to CCA measured value.

※SOH(%) fluctuates due to the rate of deterioration and charging condition.

●What is SOC (State of Charge)?

SOC is the charging condition of the battery, the state is expressed in percentage (%).

Definition of SOC in this product :

SK-8535 defines as SOC 100% when the battery voltage is higher than 12.756V. (Higher than 13.056V for the battery for industry)

※SK-8535 does not show the exact measurement voltage when testing the battery just after an engine shutdown or just after charging. Test the battery after reducing the stimulated condition according to the procedure mentioned in Page 12.

BEFORE USE

●What is Ripple Voltage?

Ripple Voltage is the feeble change of charging voltage which occurs when rectifying the generated voltage by diode. If diode is damaged, the ripple voltage fluctuated sharply and adversely affects battery and in-vehicle apparatus.

2. Language / Date & Time Settings

- Set date and time before using this instrument. (Refer to "8. Setting of Date and Time" on Page 32).
- Language changeable from English (default setting) to Japanese or simplified Chinese. (Refer to "9. Setting of Language" on Page 33).

3. Others

- Protection film is put on the front plate of the unit before shipment. Tear off the protection film before using this instrument.

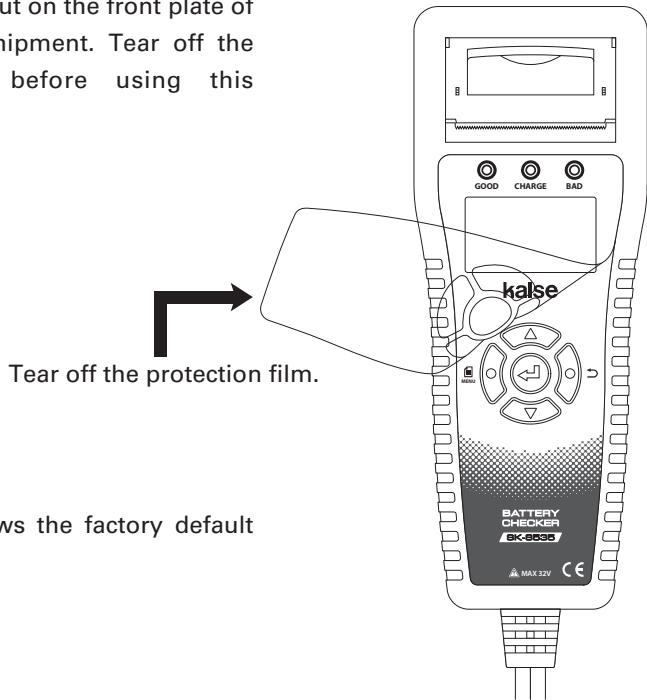

- Initial display shows the factory default settings.

MEASUREMENT PROCEDURES

1. Battery Test

CAUTION

- This instrument forced to be restarted if the testing battery is extremely exhausted and cannot afford to supply the workable current.
- Test the battery in the state of the engine shutdown to obtain the accurate measurement.
- When testing 24V battery, test each 12V battery which is connected in series.
- When testing the battery on vehicle, test the parked car after turning off the power supply of all in-vehicle apparatuses which are using the electricity from battery and locking the car door to obtain the accurate measurement.
- Test result may change when testing the same battery repeatedly. Also, test result may change when testing the weak battery after using the printer.
- Test result may change, even when testing the same battery, depending on the battery condition or change the storage environment.
- Test results may be higher than usual just after driving. When testing the battery test of such a car, test it after doing the following procedure.
 - Turn on the headlights for approx. 20 seconds.
 - Turn off the headlights and test it more than 3 minutes after turning off the headlights.

In case of the test result is "Charge/Retest" by turning on the headlights, shorten the time of turning on the headlights after re-charging the battery, and lengthen the time of intervals before testing.

When you do not perform the procedure mentioned above or testing battery unit just after charging, test after an interval more than 2 hours.

- This instrument judges the battery condition with testing the basic use of the lead battery such as charge-discharge characteristics. Test result is not for judging whether the special control function can use for the vehicle or not.
- This instrument judges the battery condition with testing the basic use of the lead battery such as charge-discharge characteristics. Test result is not for judging whether the special control function can use for the vehicle or not.

Special purpose battery such as idling stop battery may not work idling stop function due to decreasing charge acceptance occurring with long-term use. In this case ask your car dealer for check and maintenance of the battery.
- The maximum CCA displayed with this unit is up to 1400CCA.

MEASUREMENT PROCEDURES

Test Preparation

- Check the battery visually before connecting Battery Clips to the battery terminals.
- Replace the Battery Terminals if there is corrosion or crack occurs on the Terminals.
- Connect the Battery Clips to the Battery Terminals tightly without loosening.
- Clean up the Battery Terminals and Battery Clips if there is greasy dirt.
- Replace the battery which is damaged, deformed of the Battery and broken the Battery Terminals.
- Add the purified water and do auxiliary charge if the level of battery fluid decreases near to the border of LOWER.
- Replace the battery that the level of battery fluid is lower than the border of LOWER with discolored battery fluid.

Test the SOC (State of Charge) and SOH (State of Health) of the battery.

- ① Connect Black clip and Red clip to battery minus \ominus terminal and plus \oplus terminal respectively.

When you cannot connect battery clips to battery terminal directly, connect them to the point from the terminals well as close as possible.

- ※ In this case a CCA may be measured lower than a real value.

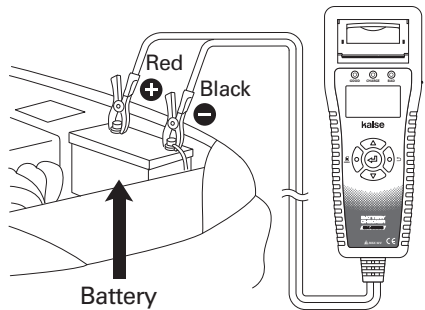

CAUTION

- Make sure to connect the Battery Clips to Battery Terminals to obtain the accurate measurement.
- Clean up the Battery Terminals and the Battery Clips before testing to obtain the accurate measurement.

MEASUREMENT PROCEDURES

- ②The instrument is powered on automatically and enters Test Battery Selection (step ③) after showing the following model number / software version number indication.

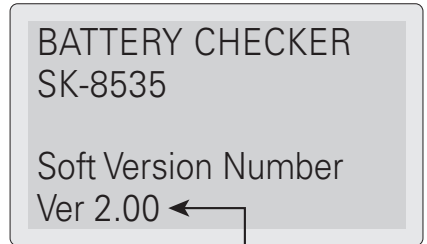
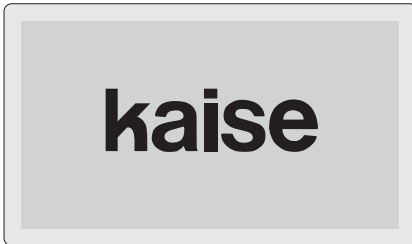

Current version number

- ③Select the battery voltage to be tested. Choose the battery voltage from 12V or 24V with using \triangle (UP SCROLL) / ∇ (DOWN SCROLL) Keys, then press \blacktriangleleft (ENTER) Key. Choose **12V battery** : Proceed to the next step ④.
Choose **24V battery** : Proceed to the step of 2. Battery System Test on Page 18.

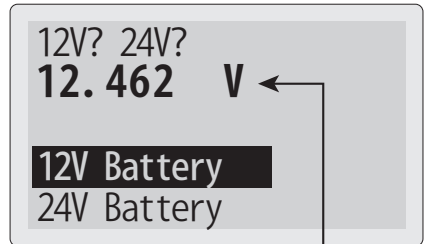

Battery voltage

※Battery voltage is displayed on the LCD.

- ④Select the battery type to be tested. Choose the battery type from the choices with using \triangle (UP SCROLL) / ∇ (DOWN SCROLL) Keys and press \blacktriangleleft (ENTER) Key.

※In case of the measurement voltage is higher than 13.6V, battery cannot be tested. WARNING screen is displayed on LCD.

※In case of the measurement voltage is higher than 16V, "OVER VOLTAGE" is displayed on LCD.

※Choose "Input CCA" if the CCA is described on the battery, otherwise choose "Industry" when testing the battery for Golf cart, Leisure boat, and Deep-cycle battery.

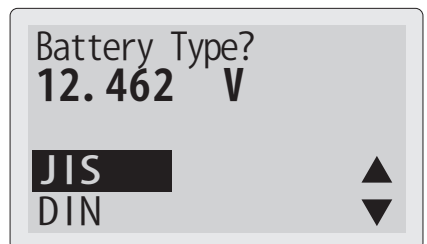

Press \blacktriangleright (BACK) Key to go back to the Battery Voltage Selection screen (Step ③).

MEASUREMENT PROCEDURES

⑤ Choose testing mode with using Δ (**UP SCROLL**) / ∇ (**DOWN SCROLL**) **Keys** and press \leftarrow (**ENTER**) **Key**. In the case of battery for the cars with charge controller or idle reduction systems, choose "Charge Controller / Idle Reduction". Otherwise choose "Standard".

※ "Industrial Rating" screen in Page 16 is displayed when choosing "Industry" at Step ④.

● If you want to test the auxiliary battery for hybrid car, choose "Hybrid Auxiliary" with using Δ (**UP SCROLL**) / ∇ (**DOWN SCROLL**) **Keys** and press \leftarrow (**ENTER**) **Key**. "Select JIS" screen in step ⑦ is displayed.

※ "Hybrid Auxiliary" cannot be selected when choosing EN(DIN), SAE(BCI), CCA Input in Step ④ on Page 14.

⑥ Select Test Mode.

Aging Test :

Choose it for deterioration check.

Unused Battery Test :

Choose it for condition check of the unused battery

Press \rightarrow (**BACK**) **Key** to go back to the Battery Type Selection screen (Step ④ on Page 14).

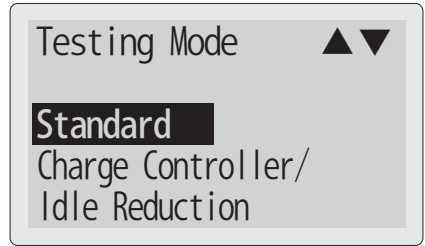

Press \rightarrow (**BACK**) **Key** to go back to the Battery Type Selection screen (Step ④ on Page 14).

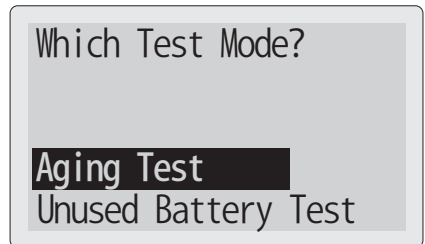
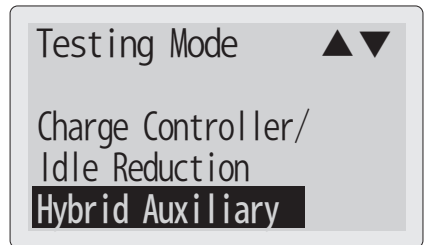

⑦ The following screen is displayed depending on the selected standards.

● **When choosing "JIS"**

Select conformable JIS type with using Δ (**UP SCROLL**) / ∇ (**DOWN SCROLL**) **Keys** and press \leftarrow (**ENTER**) **Key**. Battery test starts.

Press \rightarrow (**BACK**) **Key** to go back to the Battery Type Selection screen (Step ④ on Page 14).

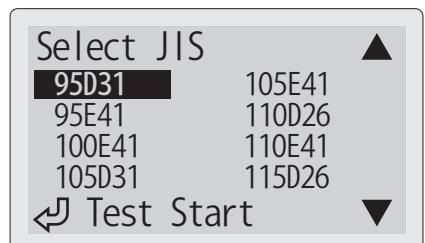

MEASUREMENT PROCEDURES

※Chosen battery standard is retained.

※If knowing only battery size like B24, D31, etc., select JIS of the greatest specifications which is replaceable.

●When choosing "EN(DIN)", "SAE(BCI)" or "CCA input"

Input the Rating with using Δ (UP SCROLL) / ∇ (DOWN SCROLL) Keys and press \leftarrow (ENTER) Key. Battery test starts.

Press \rightarrow (BACK) Key to go back to the Battery Type Selection screen (Step ④ on Page 14).

※Chosen battery standard is retained.

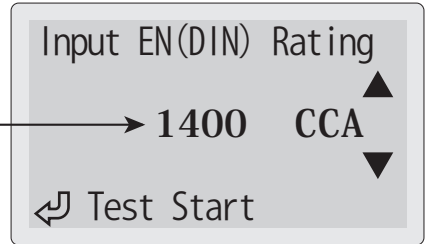

Input CCA rating

●When choosing "Industry"

Select "YES" for inputting Industrial Rating with using Δ (UP SCROLL) / ∇ (DOWN SCROLL) Keys and press \leftarrow (ENTER) Key. Battery test starts when choosing "NO".

※When choosing "NO", battery condition (good / bad) is not tested.

Press \rightarrow (BACK) Key to go back to the Battery Type Selection screen (Step ④ on Page 14).



- When testing the battery for industry, disconnect the all electric loads from the battery to obtain the accurate measurement.
- Battery test is effective for only 12V lead battery.
- Generally, industrial battery is recommended to be replaced when the internal resistance comes up to double of the unused battery. Based on this, SK-8535 judges "Bad" when the test result becomes double of the input industrial rating.

MEASUREMENT PROCEDURES

(When choosing "YES")

Input $m\Omega$ value with using Δ (UP SCROLL) / ∇ (DOWN SCROLL) Keys and press \leftarrow (ENTER) Key. Battery test starts.

Press \rightarrow (BACK) Key to go back to the Input Industrial Rating screen.

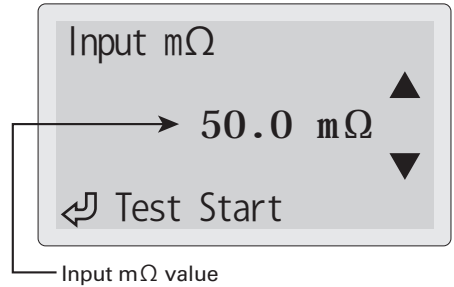

Can you find default internal resistance value of the testing battery which may be written in its body or user's manual?

YES

Input that value in this step.

NO

Select "NO" in the previous step, and test the unused (new) battery without inputting rating value to check the default internal resistance value. Then, input that value in this step.

● Inputting Battery Temperature (When temperature input setting is set "manual")
(Refer to "11. Temperature Setting" on Page 34)

When temperature input setting is set "manual", Battery Temperature Input screen is displayed as shown in the right, Input temperature in $^{\circ}\text{C}$ with using Δ (UP SCROLL) / ∇ (DOWN SCROLL) Keys and press \leftarrow (ENTER) Key. Battery test starts.
※ Input the temperatures of the battery fluid or \oplus terminal.

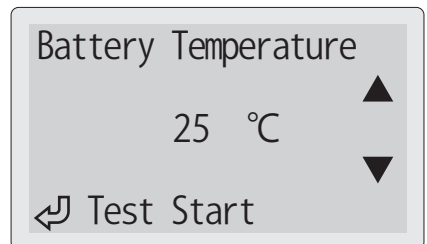

Press \rightarrow (BACK) Key to go back to input screen of each ratings

⑧ The following screen is displayed during battery testing.

※ LCD backlight turns off during testing.

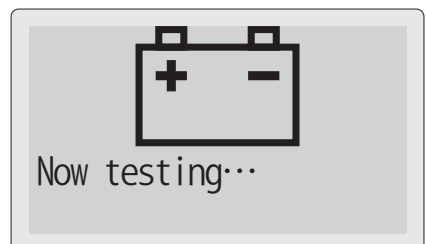

MEASUREMENT PROCEDURES

- ⑨When battery test is completed, the test result screen is displayed as shown in the right. Confirm test result with using \triangle (UP SCROLL) / ∇ (DOWN SCROLL) Keys.

LED indicator lights up or flashes depending on a test result as follows.

- Green LED lights up when the test result is "Good"
- Green & Yellow LED lights up when the battery is fine but needs re-charging
- Yellow LED lights up when the test result is "Charge/Retest"
- Yellow LED flashes when the test result is "Caution"
- Red LED lights up when battery test result is "Replace"

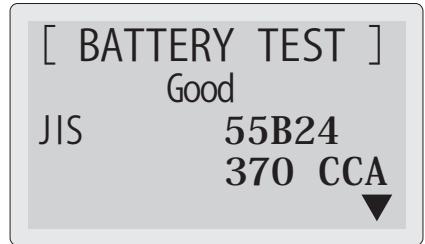
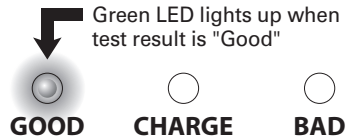

※The following results are displayed.

- Battery test result
- Model (JIS only)
- Selected battery type
- SOH (State of Health)
- CCA value (Standard $m\Omega$ for Industry)
- Measured CCA (measured $m\Omega$ for Industry)
- Temperature
- SOC (State of Charge)
- Battery voltage
- Testing method
- Testing Mode
- Comment

※Operating instructions are displayed in the last page of the test result.

Press \blacktriangleleft (ENTER) Key : Enter Battery System Test

Press  (MENU) Key : Move to Menu screen (Print / Save Data / Delete Save Data)

(Page 23)

※Make sure to input Industrial Rating when testing battery condition (good / bad) of industrial battery.

※In case of the test result of the Battery Test is "Replace (Cell Defect)", charge battery fully, and test it again and judge with observing a state of the battery.

※For the vehicle equipped with higher grade battery, start performance of engine may have no problem even if the judgment result is "Replace". In this case, battery replacement is recommended to prevent suddenly battery breakdown.

The battery which is not charged for a long term may be judged "Replace" due to decreasing CCA by self-discharge even if it is a new battery. Keep the battery with periodical auxiliary charge to prevent deterioration by leaving with exhausted condition for a long term.

MEASUREMENT PROCEDURES

※If the error message shown right is displayed, disconnect Battery Clips from the battery and check about the following items.

① **Check for the battery and car**

Make sure there are not any dirt or abnormality on the battery terminals and terminal cables.

② **Check for SK-8535**

Make sure there are not any dirt or abnormality on the metal part of battery clips and clip cables.

※Battery may be damaged if keeping getting errors in spite of checking above.

When the error message is kept displaying or measurement error is displayed even if testing another battery, ask repair service to us, KAISE CORPORATION through your local dealer.

※When the test result is "Charge/Retest" or "Replace", the message shown right is displayed. Select "YES" and press **↵(ENTER) Key**, the test result is settled. Select "NO" and press **↵(ENTER) Key**, the message: "Please charge battery, and test it again." is displayed as comment of test result.

※Select "YES" when the test result is "Charge/Retest", the test result changes "Replace".

Error

Restart the unit and test again.
Check error point.

Auxiliary charge finished?

YES

NO

Press **↵(ENTER) Key**, to move to "2. Battery System Test" on Page 20.

⑤The message shown right is displayed when selecting "Hybrid Auxiliary" at "Industry", "Which Test Mode?" or "Testing Mode?". Select "YES" and press **↵(ENTER) Key** to go back to the Battery Voltage Selection screen (Step ③ on Page 14). Select "NO" and press **↵(ENTER) Key** to go back to the Battery Test Result screen (Step ⑨ on Page 18).

Do you want to exit?

YES

NO



CAUTION

●Do not pull Battery Clips forcibly when detaching from the battery. It may damage the battery terminals.

MEASUREMENT PROCEDURES

2. Battery System Test

Start performance ability of the battery (the ability that battery starts an engine) and charging system on vehicle (condition of alternator) are testable.

※Battery System Test for 12V battery is available after the Battery Test.

① Press **↵ (ENTER) Key** during Battery Test Result screen (step ⑨ on page 18) to enter Battery System Test mode. Make sure to turn off the battery loadings, and press **↵ (ENTER) Key**.

※When choosing 24V battery at the Battery Voltage Selection screen (step ③ on page 14), Battery System Test screen shown right is displayed.

BATTERY SYSTEM TEST

Turn off all electric car accessories.

↶ Start

Press **↶ (BACK) Key** to go back to the Result of Battery Test screen (Step ⑨ on Page 18) or the Battery Voltage Selection screen (Step ③ on Page 14).

CAUTION

- Make sure to turn off the battery loadings (all electric components on the vehicle are turned off) to obtain the accurate measurement.
- When doing Battery System Test for 24V battery, connect the instrument in 24V and select 24V Battery at Battery Voltage Selection Screen in step ③ on Page 14.
- Battery System Test is not applicable to the battery unit only, or the in-vehicle battery which does not for engine starting purpose.

② Start an engine after the following screen is displayed.

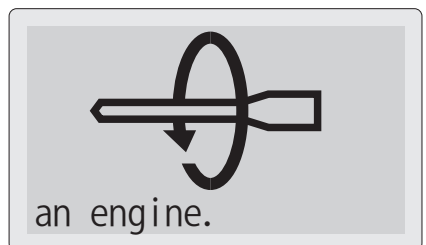
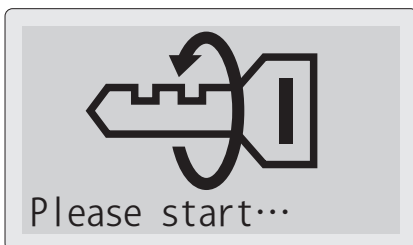

MEASUREMENT PROCEDURES

- ③ Battery System Test starts when detecting a voltage change of the battery.
- ※ The screen shown right is displayed during Battery System Test. (about 1 minute max)

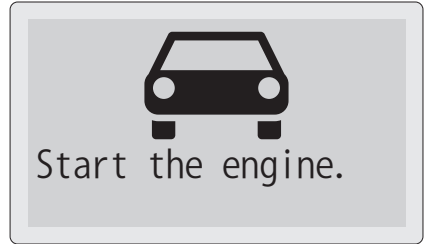

- ※ If retest is necessary after Battery System Test, the right screen is displayed.
- ※ Select **YES** and press **↵ (ENTER) Key**, the below left screen is displayed. Turn on the air conditioner (maximum power) and head lights (high beam) with an engine running, then press **↵ (ENTER) Key**. Retest starts.

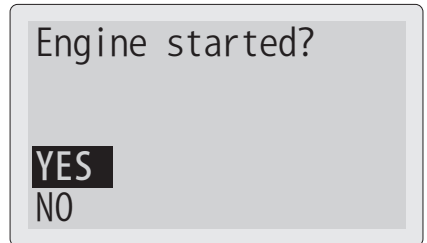

- ※ Select **NO** and press **↵ (ENTER) Key**, Battery System Test Result is displayed as shown in Step ④. (judgement is done with the measured value.)

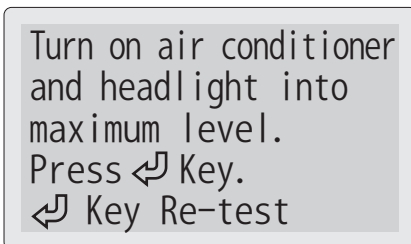

Retest

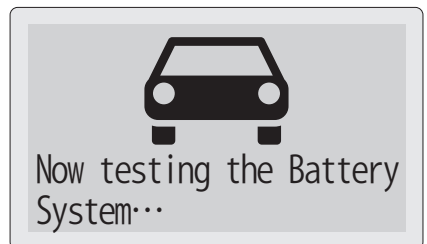

- ④ When Battery System Test is completed, Test Result screen is displayed as shown in the right. Confirm Test Result with using **△ (UP SCROLL) / ▽ (DOWN SCROLL) Keys**.

LED Indication lights up depending on the Test Result as follows.

- Green LED lights up when the all test results are "Good".
- Red LED flashes when engine startability is weakened.
- Red LED lights up when the charging system is weakened or both engine startability and charging system are weakened.

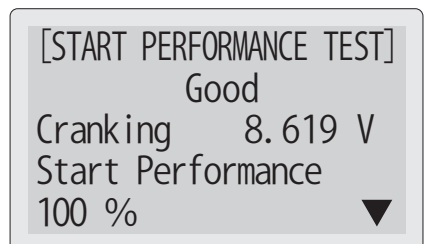
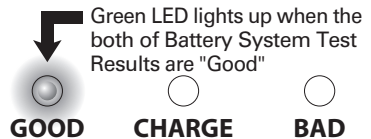

MEASUREMENT PROCEDURES

※The following results are displayed.

- Start performance test result
- Starting voltage (cranking battery voltage)
- Start performance (the ability that battery starts an engine)
- Charging system test result
- Charging voltage (battery voltage at the time of charging)
- Ripple voltage (ripple voltage of diode)
- Comment

※Operating Instructions are displayed in the last page of the test result.

Press **↵ (ENTER) Key** to move on to the Exit screen.

Press **☰ (MENU) Key** to move on to the Menu screen (Print / Save Data / Delete Save Data). (refer to Page 23)

※The measurable battery voltage of this product is DC8V or higher, but the testing carries out normally even if the battery voltage drops lower than DC8V during Start Performance Test.

※Start Performance Test is not applicable to check the starter condition.

※The message "Start Performance 0%" means that the tested battery almost has no power to start an engine. It does not mean the starting probability.

※When re-testing, turn on the electric components as much as possible. (fog lamp, rear defroster, room lamp, etc.)



CAUTION

Do not forget to turn off the electric components after finishing the re-test.

- ⑤The right screen is shown when pressing **↵ (ENTER) Key** at the Battery System Test Result screen. Select **YES** and press **↵ (ENTER) Key** to go back to Step ③ Battery Voltage Selection screen on Page 14. Select **NO** and press **↵ (ENTER) Key** to go back to Step ④ Result of Battery System Test screen on Page 21.

Do you want to exit?

YES
NO

Press **⏪ (BACK) Key** to go back to the Result of Battery System Test screen (Step ④ on Page 21).



MEASUREMENT PROCEDURES



3. Print Out

This instrument can print out the results of Battery Test and Battery System Test.

※Unclear printing or unstable operation of this instrument may occur when using weak battery for printing. In this case, save the test results in reference to "4. Test Result Saving" on Page 26, then print them out with good battery or PC in reference to "7. Connecting to PC" on Page 30.

①Menu screen shown right is displayed by pressing  (**MENU**) Key on the Result of Battery Test screen (Step ⑨ on Page 18) or the Result of Battery System Test screen (Step ④ on Page 21).

Select "**Print**" with using  (**UP SCROLL**) /  (**DOWN SCROLL**) Keys and press  (**ENTER**) Key.

②The Confirmation screen as shown in the right is displayed. Select **YES** and press  (**ENTER**) Key to print the test results. Select **NO** and press  (**ENTER**) Key for go back to Menu screen.

※If printing becomes dark by continuous printing, stop printing for a while for cooling down the printer thermal head.

※The right screen is displayed during printing. It goes back to Menu screen (Step ①) after finishing printing.

※Make sure to close printer cover to avoid any printing error.

※Printing is disabled in case of paper jam. Open the printer cover and fix the paper for re-print.

※The right screen is displayed when Printer Paper is running out or unset. Set new Printer Paper in reference to "1. Printing Paper Setup" on Page 37.

※This may not be displayed due to misrecognition of the sensor.

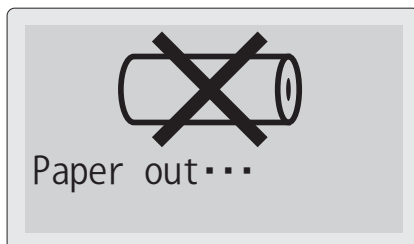
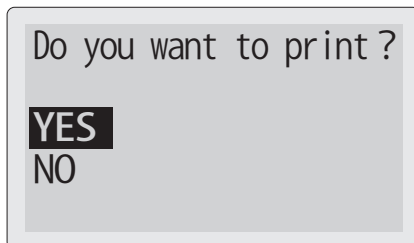
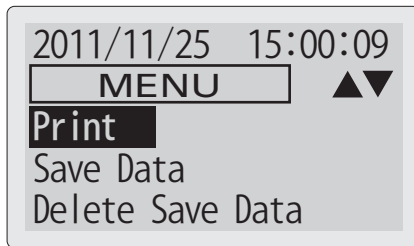

MEASUREMENT PROCEDURES

Printing Sample

Store name and person in charge

Testing date and time

Battery test mode
Battery test result

Condition of tested battery

Battery charging level (SOC)

Battery aging level (SOH)

Engine start performance test result

Battery conditions at engine starting

Charging system test result

Battery conditions when charged

Comment for test result

Battery Test Report

Store Name _____

Person in Charge _____

Date and Time
2013/5/15 15:00

BATTERY TEST

• (Aging Test Mode)

• **Test Result : Good** •

Battery Type _____ JIS
 Battery Size _____ Q-85
 Rated CCA _____ 530CCA
 Measured CCA _____ 615CCA
 Battery Voltage _____ 12.780V
 Battery Temperature _____ 24°C
 Testing Mode _____
 Charge Controller/Idle Reduction _____

SOC (State of Charge): 100 %



SOH (State of Health): 100 %



START PERFORMANCE TEST

• **Test Result : Good**

Cranking _____ 8.619V
 Start Performance _____ 100%

CHARGING SYSTEM TEST

• **Test Result : Good**

Charging Voltage _____ 14.523V
 Ripple Voltage _____ 0.110V

Periodical test is recommended.

※If battery system test is skipped, the result of Start Performance Test and Charging System Test are not printed.

※Saved data is printed out with a current setting language of this instrument.

(e.g. : The data saved in Japanese is printed in English if the present setting is "English".)

MEASUREMENT PROCEDURES

Test Result

Five levels: ①Good ②Good/Charge ③Caution ④Charge/Retest ⑤Replace

●Check Point

In case of the test result "Caution", increase frequency of battery test because deterioration of the battery is progressing.

●Advice

It is effective to get auxiliary charged of the battery periodically to be able to use the battery for a long time.

Recently the battery is used with over discharge condition due to fuel saving technology. Moreover, in case of having a short-distance driving such as infrequent driving or town driving, function of vehicle side such as idling stop may not work due to degradation of charging receiving performance by acceleration of the battery deterioration or keeping over discharging condition.

State of Health (SOH) %

Test result "Replace" when SOH is 23% or lower.

●SOH is obtained from the ratio of rated CCA value and measured CCA value, and amount of charge of the battery (SOC) comprehensively.

Start Performance Test

Test result "Weak Start Power" when start performance is 50% or lower.

※Cranking Voltage is the minimum voltage in cranking. (sampling rate: 100 μ s)

●Advice

Comprehensive judgement is possible by the test result of Engine Start Performance Test and Battery Test.

(For example) The result of Battery Test is "Caution" and test result of Start Performance is around 25% in summer-time, replace with a new battery before winter sets in due to start performance of the engine decreases in cool season.

※Start performance may be judged lower even if battery is new for the battery which has small capacity for engine displacement.

Charging System Test (12V battery)

Charging Voltage : Test result "Good" when battery voltage is 13V or higher and 16V or lower.

Ripple Voltage : Test result "Good" when ripple voltage is 1V or lower.

MEASUREMENT PROCEDURES

4. Test Result Saving

This instrument can save the result of Battery Test and Battery System Test up to 99 data.

※Each data is saved with following file name.

■Example of file name (In case of the third time on the same day, May 15th, 2013)

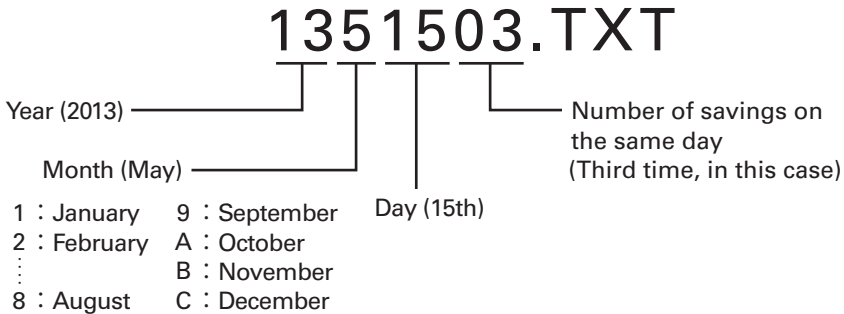

※Saved date and time reflect the date and time settings of this instrument. Make sure to set them correctly in reference to "8. Setting of Date and Time" on Page 32.

①Menu screen is displayed as shown in the right by pressing  (**MENU**) Key during displaying the Result of Battery Test screen (Step ⑨ on Page 18) or the Result of Battery System Test screen (Step ④ on Page 21). Select "**Save Data**" with using Δ (**UP SCROLL**) / ∇ (**DOWN SCROLL**) Keys, and press \leftarrow (**ENTER**) Key.

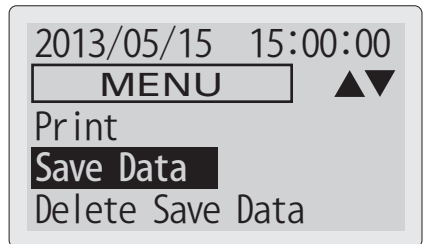

②Confirmation screen as shown in the right is displayed. Select "**YES**" and press \leftarrow (**ENTER**) Key for saving the test result. Select "**NO**" and press \leftarrow (**ENTER**) Key for go back to Menu screen (previous Step ①).

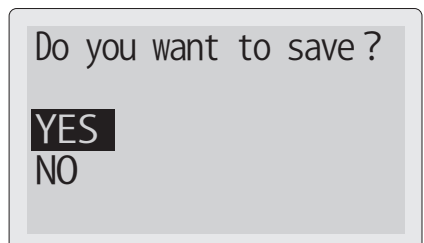

Press \rightarrow (**BACK**) Key to go back to Menu screen (previous Step ①).

MEASUREMENT PROCEDURES

※Up to 99 data can be saved to the internal memory. If the saved data exceeds 99, the message as shown in the right is displayed. Delete unnecessary data in reference to "6. Delete the Saved Data" on Page 29.

–WARNING–
Can't save the data.
The number of saved data exceed the limit.

※If there is not enough memory capacity, the message as shown in the right is displayed. Delete unnecessary data in reference to "6. Delete the Saved Data" on Page 29 to increase storage capacity.

–WARNING–
Can't save the data.
Out of memory capacity.

※If the data with same file name have already existed, the message as shown in the right is displayed. Delete data with same file name in reference to "6. Delete the Saved Data" on Page 29.

–WARNING–
Can't save the data.
The same file name existed.

※File name consists of the saving date. Refer to "Example of file name" on page 26 for details.

※Saved data is deletable from PC when connecting.

※When system error occurs, the message as shown in the right is displayed. Stop test and format Removable Disk in reference to "2. Formatting of Removable Disk" on Page 39.

System Error
Can't save the data.

※All saved data are deleted after formatting removable disk.

MEASUREMENT PROCEDURES

5. View the Saved Data

Saved data can be displayed in the following procedures.

① Menu screen as shown in the right is displayed by pressing  (MENU) Key during displaying Battery Voltage Selection screen (Step ③ on Page 14) or Battery Type Selection screen (Step ④ on Page 14). Select "View Save Data" with using Δ (UP SCROLL) / ∇ (DOWN SCROLL) Keys and press \leftarrow (ENTER) Key.

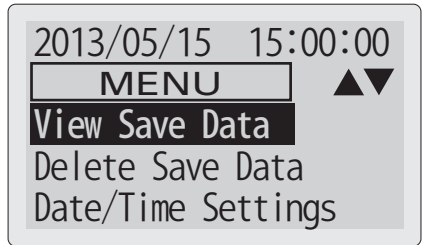

② The Data List screen as shown in the right is displayed. Choose the data to be displayed by Δ (UP SCROLL) / ∇ (DOWN SCROLL) Keys and press \leftarrow (ENTER) Key.

※ If there is no saved data, "No data found" is displayed.



Press \rightarrow (BACK) Key to go back to Menu screen (previous Step ①).

③ Saved data are displayed as shown in the right. Display can be scrolled with using Δ (UP SCROLL) / ∇ (DOWN SCROLL) Keys.

※ The data on the current screen can print out by pressing  (MENU) Key. Refer to "3. Print Out" on Page 23 for details.

※ Saved data is displayed in a current setting language of this instrument.

(e.g. : If English is set now, every data saved in Japanese are displayed in English.)

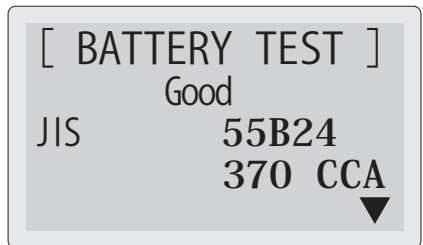

Press \rightarrow (BACK) Key to go back to Data List screen (previous Step ②).

※ When system error occurs, the message as shown in the right is displayed. Stop test and format Removable Disk in reference to "2. Formatting of Removable Disk" on Page 39.

※ All saved data are deleted after formatting removable disk.

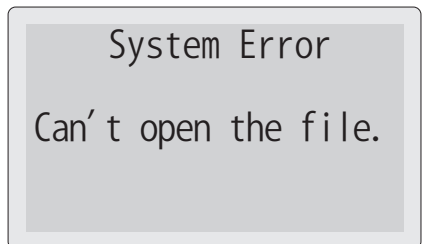

MEASUREMENT PROCEDURES

6. Delete the Saved Data

Saved data can be deleted in the following procedures.

- ① Menu screen is displayed by pressing  (MENU) Key during displaying Battery Voltage Selection screen (Step ③ on Page 14), Battery Type Selection screen (Step ④ on Page 14), the Result of Battery Test screen (Step ⑨ on Page 18) or the Result of Battery System Test screen (Step ④ on Page 21). Select "Delete Save Data" with using Δ (UP SCROLL) / ∇ (DOWN SCROLL) Keys and press \leftarrow (ENTER) Key.

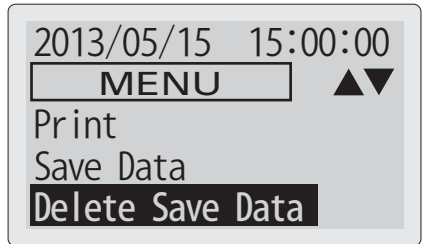

- ② The Data List screen as shown in the right is displayed. Choose the data to be deleted by Δ (UP SCROLL) / ∇ (DOWN SCROLL) Keys and press \leftarrow (ENTER) Key.



※If there is no saved data, "No data found" is displayed.

Press \rightarrow (BACK) Key to go back to Menu screen (previous Step ①).

- ③ Confirmation screen as shown in the right is displayed. Select "YES" and press \leftarrow (ENTER) Key, deleting the data starts. Select "NO" and press \leftarrow (ENTER) Key for go back to Data List screen (previous Step ②).

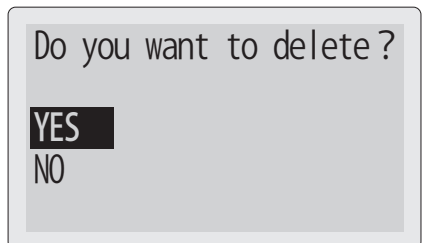

Press \rightarrow (BACK) Key to go back to Data List screen (previous Step ②)

※When system error occurs, the message as shown in the right is displayed. Stop test and format Removable Disk in reference to "2. Formatting of Removable Disk" on Page 39.

※All saved data are deleted after formatting removable disk.

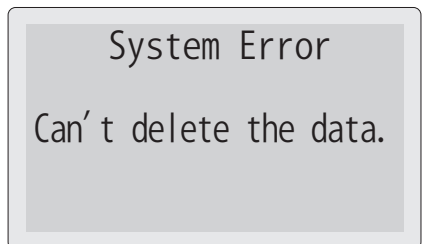

MEASUREMENT PROCEDURES

7. Connecting to PC

Data transfer to PC in text format is possible. Use provided USB cable for PC connection.

- ① Insert the provided USB cable to the USB port on the right side of the unit and connect another side to PC.

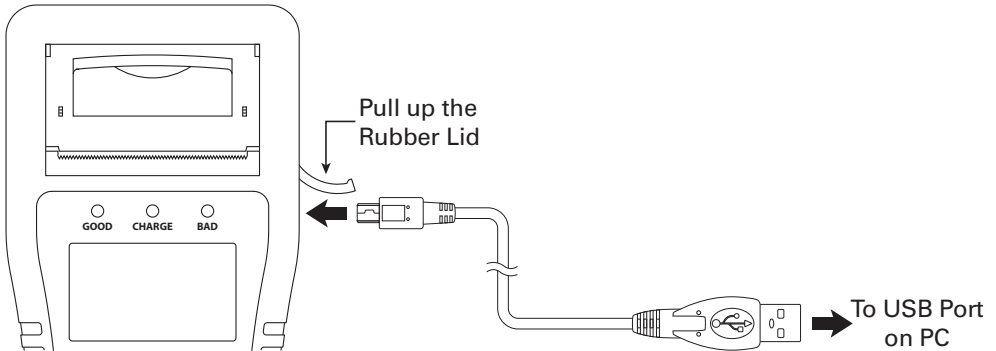

- ② The instrument turns on automatically when connecting to active PC. Messages as shown in the right are displayed.

※ Internal memory is recognized as mass-storage device (kaise SK-8535 USB Device) when PC connection is completed.

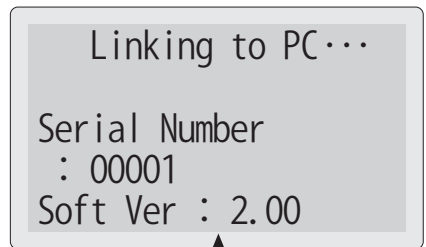

Current version number is displayed.



CAUTION

- Detach USB Cable after completing USB removing process from PC to prevent unexpected trouble.

MEASUREMENT PROCEDURES

- ③ Access to the memory of this instrument by PC operation to copy and paste the data to the PC. Data format is "text" which is suitable for print out from PC.

■ PC screen display example

The screenshot shows a Notepad window titled "1351503.TXT - Notepad" containing a "Battery Test Report". The report includes the following sections and data points:

- Date and Time:** 2013/05/15 15:00:00
- Battery Test (Aging Test Mode):** Test Result : Good
- Condition of tested battery:** Battery Type : JIS, Battery Size : Q-85, Rated CCA : 530CCA, Measured CCA : 615CCA, Battery Voltage : 12.780V, Battery Temperature : 24°C, Testing Mode : Charge Controller/Idle Reduction
- Battery charging level (SOC):** 100%
- Battery aging level (SOH):** 100%
- Start Performance Test:** TestResult : Good, Cranking : 8.619V, Start Performance : 100%
- Charging System Test:** Test Result : Good, Charging Voltage : 14.523V, Ripple Voltage : 0.110V
- Comments for test result:** Periodical test is recommended.

- ※ Data is displayed in the setting language at the time of saving.
 - ※ If the data saved in Chinese, open it with the application which can display in simplified Chinese. Characters may be garbled with the Notepad which is installed by default except in Chinese PC.
- ④ Detach USB Cable after completing USB removing process from PC to prevent unexpected trouble.

MEASUREMENT PROCEDURES

8. Setting of Date and Time

① Menu screen is displayed by pressing  (MENU) Key at Battery Voltage Selection screen (Step ③ on Page 14) or Battery Type Selection screen (Step ④ on Page 14). Select "Date/Time Settings" with using Δ (UP SCROLL) / ∇ (DOWN SCROLL) Keys and press \leftarrow (ENTER) Key.

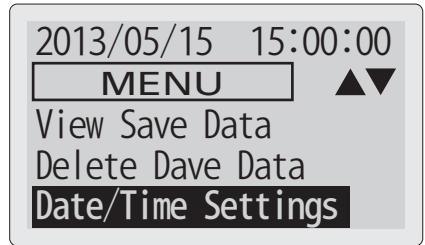

② Date/Time Setting screen is displayed. (Year (Y) is blinking)

Press \rightarrow (BACK) Key to go back to Menu screen (previous Step ①).

※ The present settings are displayed.

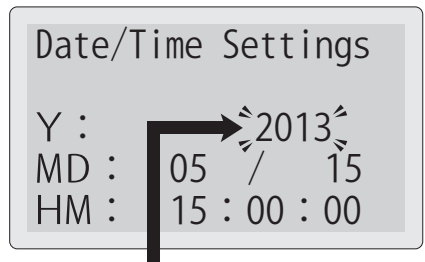

The value of Year blinks.

③ Set "Year" with using Δ (UP SCROLL) / ∇ (DOWN SCROLL) Keys and press \leftarrow (ENTER) Key. Then "Month" starts to blink. Set "Month" and press \leftarrow (ENTER) Key, Set the "Day" in the same way.

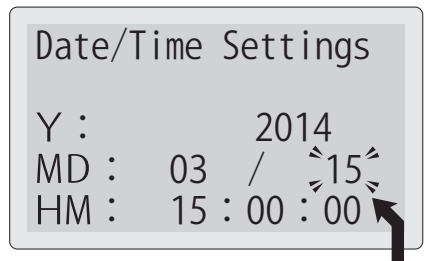

The next setting blinks by pressing \leftarrow (ENTER) Key.

④ Set Time (HM) until Minute in the same way as previous steps and press \leftarrow (ENTER) Key. Date/Time Settings are completed with resetting "Second" to 00 and goes back to Menu Screen (Step ① on page 29).

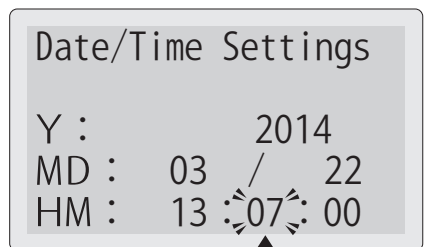

Set until the value of Minute, then press \leftarrow (ENTER) Key.

MEASUREMENT PROCEDURES

9. Setting of Language

- ① Menu screen is displayed by pressing  (MENU) Key at Battery Voltage Selection screen (Step ③ on Page 14) or Battery Type Selection screen (Step ④ on Page 14).
Select "Select Language" with using Δ (UP SCROLL) / ∇ (DOWN SCROLL) Keys and press \leftarrow (ENTER) Key.

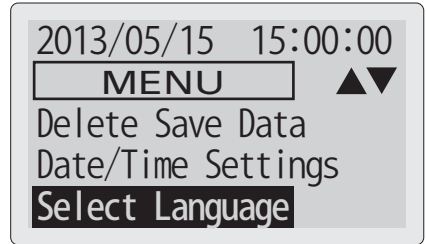

- ② Language Selection screen as shown in the right is displayed. Select "日本語" for Japanese, "ENGLISH" for English or "中文" for Simplified Chinese with using Δ (UP SCROLL) / ∇ (DOWN SCROLL) Keys and press \leftarrow (ENTER) Key. Language Setting is completed and goes back to Menu screen.



Press \rightarrow (BACK) Key to go back to Menu screen (previous Step ①).

10. Contrast Adjustment

- ① Menu screen is displayed by pressing  (MENU) Key at Battery Voltage Selection screen (Step ③ on Page 14) or Battery Type Selection screen (Step ④ on Page 14).
Select "Contrast Control" with using Δ (UP SCROLL) / ∇ (DOWN SCROLL) Keys and press \leftarrow (ENTER) Key.

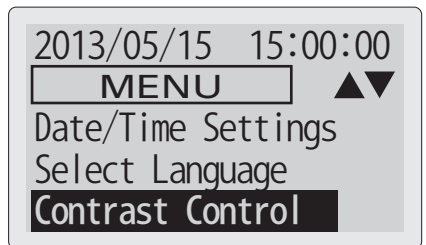

- ② LCD contrast can adjustable on a scale of 0 to 30 with using Δ (UP SCROLL) / ∇ (DOWN SCROLL) Keys.

Press \leftarrow (ENTER) Key to complete contrast adjustment and goes back to Menu screen. (previous Step ①)

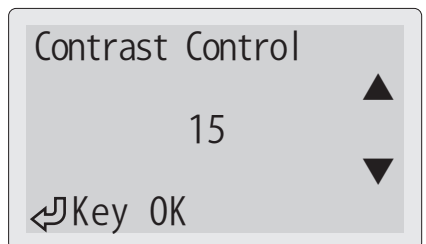

Press \rightarrow (BACK) Key to go back to Menu screen (previous Step ①).

MEASUREMENT PROCEDURES

11. Temperature Setting

Temperature of the battery at Battery Test can be set manually.

① Menu screen is displayed by pressing  (MENU) Key at Battery Voltage Selection screen (Step ③ on Page 14) or Battery Type Selection screen (Step ④ on Page 14).
Select "Temperature Setting" with using Δ (UP SCROLL) / ∇ (DOWN SCROLL) Keys and press \leftarrow (ENTER) Key.

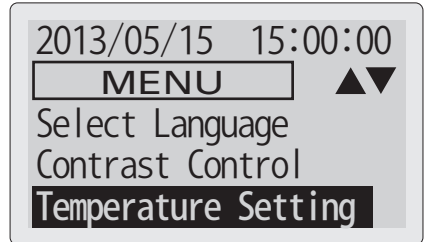

② Automatic temperature measurement is set as default, select "Manual" with using Δ (UP SCROLL) / ∇ (DOWN SCROLL) Keys and press \leftarrow (ENTER) Key. Manually temperature inputting is set and goes back to Menu screen. (previous Step ①)

※ In case of manual temperature inputting, it is necessary to inputting the battery temperature manually at Battery Test. (Refer to Page 17)

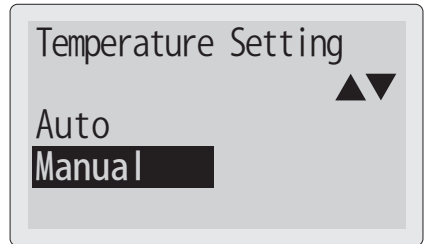

Press \rightarrow (BACK) Key to go back to Menu screen (previous Step ①).

MEASUREMENT PROCEDURES

12. CCA Value List for Battery Manufacturers and Their Models

- Confirm the battery standard (model) and input modes, EN(DIN), SAE(BCI) or CCA Input, when input CCA value of the battery.
- If the CCA value printed on the testing battery is different from this table, input the printed value.

This publication CCA value is subject to change without a notice due to the battery maker's reasons. (as of June, 2013 / according to our own research)

AC Delco			
EN(DIN)		SAE(BCI)	
Model	CCA	EN(DIN)	
20-55	630	26-6MF	550
20-55D	525	34-6MF	535
20-60	500	34-7MF	700
20-66	500	58-5MF	430
20-70	650	58-6MF	560
20-72	700	58R-6MF	585
20-80	780	65-6MF	650
20-90	850	65-7MF	850
20-92	600	75-6MF	650
20-100	800	75-7MF	735
20-110	1000	78-6MF	675
27-44	400	78H-6MF	675
27-45H	400	78-7MF	770
27-50P	500	78DT-7MF	850
27-54H	500	79-6MF	880
27-55	500	86-7MF	690
27-60P	550	90-6MF	600
27-63H	550	101-6MF	690
27-66	550	DCD26L	500
27-70P	630	DCD26R	500
27-80	780	85BR60K	610
27-85	770	Voyager Marine	
Model	CCA	SAE(BCI)	
27-90	850	M24MF	400
30-55	525	M27MF	550
30-66	500	M31MF	625
30-72	700	Deep cycle	
Model	CCA	SAE(BCI)	
DC24			500
DC27			580
DC31			660
1111			750
1150			625
1151			625
31-901CT			900
759			950

BOSCH			
PS-I Battery		Silver	
Model	CCA	EN(DIN)	
PSI-4C	360	SL-4C	360
PSI-6C	480	SL-4D	360
PSI-6H	600	SL-4E	420
PSI-7C	680	SL-4K	300
PSI-7G	640	SL-4L	300
PSI-7H	680	SL-4P	420
PSI-1A	760	SL-5D	420
High TEC AGM Battery			
Model	CCA	EN(DIN)	
HT-70-PN	760	SL-6C	480
HT-95-PN	850	SL-6H	600
Silver X			
Model	CCA	EN(DIN)	
SLX-5K	550	SL-7C	680
SLX-4E	460	SL-7F	680
SLX-4K	300	SL-7G	640
SLX-4L	300	SL-7H	680
SLX-6C	650	SL-8B	760
SLX-6H	610	SL-8C	720
SLX-7C	790	SL-1A	760
SLX-7F	730	SL-1B	850
SLX-7H	730	US Power Max	
Model	CCA	SAE(BCI)	
SLX-8B	810	UPM-78DT	830
SLX-8C	810	UPM-75	650
SLX-1A	910	UPM-65	750
SLX-1B	850	UPM-58	600
		UPM-58R	600
		UPM-34	610

MEASUREMENT PROCEDURES

ATLAS

EN	
Model	CCA EN (DIN)
572-20	610
571-13	640
544-59	390
4DLT	890
543-17	410
554-57	480
562-19	540
568-18	550
580-43	640
585-15	720
600-38	850

BCI

Model	CCA SAE (BCI)
78DT-600	600
58-560	560
75-550	550
78-600	600

AGM

Model	CCA SAE (BCI)
AGM-RD26	730
AGM-YD26	750

VARTA

Ultra Dynamic

Model	CCA SAE (BCI)
570901076	760
595901085	850

Silver Dynamic

Model	CCA EN (DIN)
552401052	520
554400053	530
561400060	600
563400061	610
563401061	610
574402075	750
577400078	780
585200080	800
600402083	830
610402092	920

EXIDE

EA Series	
Model	CCA EN (DIN)
EA530	540
EA602	600
EA640	640
EA722	720
EA770	760
EA1000	900

Eco Power X

Model	CCA EN (DIN)
EPX50	450
EPX55	520
EPX62	570
EPX65	630
EPX75	730
EPX80	640
EPX100	870

For American Cars

Model	CCA SAE (BCI)
EX78DT	850
EX75	730
EX65	850
EX58	540
EX58R	580
EX34	630
EX86	525
EX36R	650
EX31	700

Orbital Series

Model	CCA SAE (BCI)
ORB34XCD	750
ORB78DT	770
ORB75DT	690

Gel Battery

Model	CCA SAE (BCI)
G210	1100

HEXA

Model	CCA SAE (BCI)
58-6MF	585
58R6MF	585
34-72	535
65-7MF	650
75-6MF	650
78-6MF	675
M24MF	550
M27MF	570
M31MF	625

MOLL

MOLL AGM	
Model	CCA EN (DIN)
81070	760
81095	850

m3 plus

Model	CCA EN (DIN)
83046	420
83056	500
83058	540
83071	590
83075	660
83085	710
83091	760
83095	800
83110	850

Kamina Start

Model	CCA EN (DIN)
07715	360
54459	360
54464	360
54577	300
54579	300
55565	420
55559	420
56219	480
56638	510
57024	540
57414	680
57539	640
60038	850
60032	680
595203076	760
61042	800

ODYSSEY

Model	CCA SAE (BCI)
LB545	230
LB680	280
LB925	470
LB1200	630
LB1700	900

OPTIMA

Red Top	
Model	CCA SAE (BCI)
1050S	815
1050U	815
925S	730
925U	730

Yellow Top

Model	CCA SAE (BCI)
D1400S	975
D1000S	765
D1000U	765
YT-925SL	660
YT-925U	660
YT-B24	460

Blue Top

Model	CCA SAE (BCI)
D1400M	975
D1200M	845
D900M	765
SLI-4.2L	815

GS YUASA

EU Series	
Model	CCA EN (DIN)
545-042	420
555-054	540
560-064	640
562-048	480
570-064	640
574-068	680
580-072	720
600-080	800

MAINTENANCE

1. Printing Paper Setup

The screen as shown in the right is displayed when Printer Paper is running out or unset. Set new Printer Paper in the following procedure.

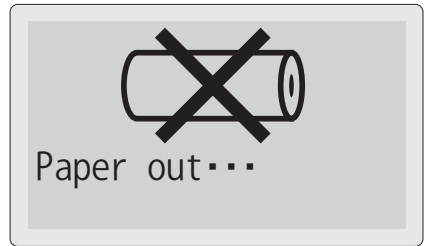

① Pull up Printer Lever as shown in the right. Printer Cover lifts up.

※ Do not pull up the printer lever more than necessary. It causes damage to the printer lever.

※ Do not apply heavy pressure on Printer Lever or Printer Cover to prevent trouble or damage to this instrument.

② Open the Printer Cover and remove old printer paper. Take the new printer paper out of the wrapping bag.

③ Peel off the seal fixing new roll paper end. Set new printer paper with printable side (smoothly-textured inner surface) facing downward with rolling it out a little.

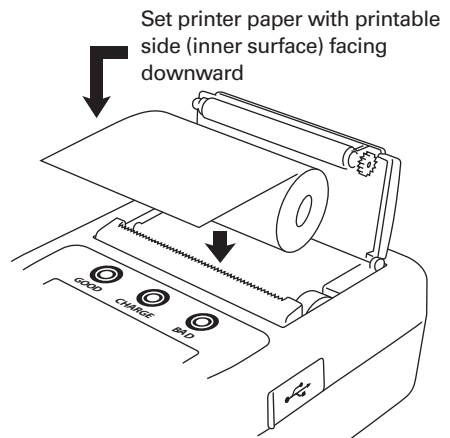
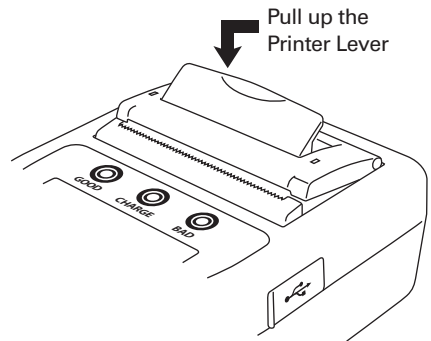

CAUTION

- Do not apply heavy pressure on Printer Lever or Printer Cover to prevent trouble or damage to this instrument.
- Set new printer paper with printable side (smoothly-textured inner surface) facing downward. Wrong surface is not capable of printing.

MAINTENANCE

- ④ Push down the Printer Lever, then close Printer Cover with putting it over the printer paper. Cut the extra paper away.
- ※ Be sure to push both side of Printer Cover when closing it. Pushing center part of Printer Cover causes trouble or damage to the printer module.

Close the Printer Cover with pushing both side. (Do not push center part.)

 Push down this Printer Lever first.

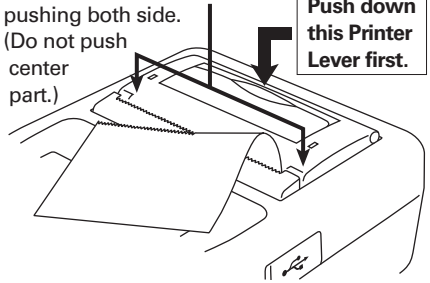

CAUTION

- Push down the Printer Lever first when closing Printer Cover. To prevent any trouble or damage to the printer module.
- Be sure to push both side of Printer Cover when closing it. Pushing center part of Printer Cover causes trouble or damage to the printer module.
- Do not keep the Printer Paper in any place where it will be subjected to direct sunlight or high temperatures/humidity to prevent discoloration.
- Keep this instrument in supplied Carrying Case to avoid malfunction of the printer trouble by dust penetration.
- Keep out dust into the printer when setting the Printer Paper to prevent malfunction of the printer. Especially when the dust is getting into the gear wheel part, the printer does not work.
- Do not keep this instrument in the dusty area to prevent malfunction of the printer.

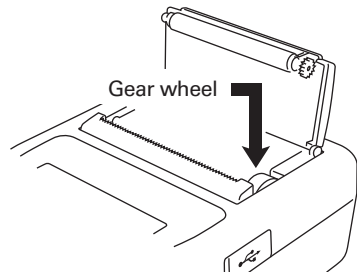

MAINTENANCE

2. Formatting of Removable Disk



CAUTION

● All saved data are deleted after formatting removable disk.

- ① Insert the provided USB cable to the USB port on the right side of the unit and connect another to PC.
- ② Select the appropriate removable disk on PC. Check a "Quick Format" option, and click "Start".

Tick a "Quick Format"
then click "Start".

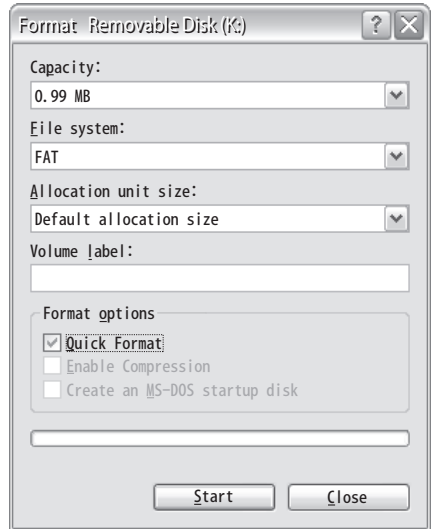

- ③ Disconnect USB Plug from PC after finishing quick format.
- ※ Detach USB Cable after completing USB removing process from PC to prevent unexpected trouble.
- ④ Connect the USB Cable to PC again. The following messages are displayed and start formatting the internal memory.

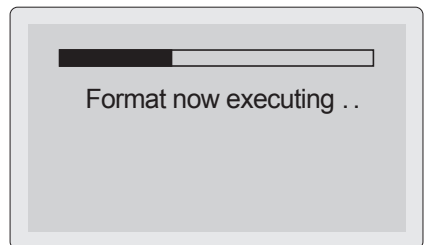
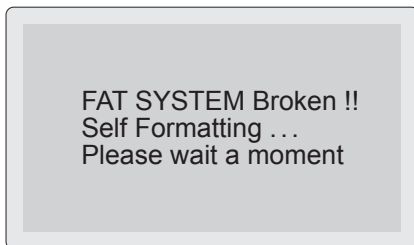

MAINTENANCE

- ⑤Format of Removable Disk is completed when the screen shown right is displayed after finishing the internal memory formatting.

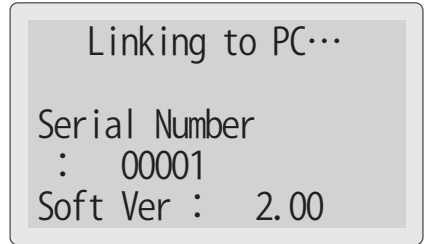

- ⑥Detach USB Cable after completing USB removing process from PC to prevent unexpected trouble.

3. Periodical Check and Calibration

Periodical check and calibration is necessary to make safety measurements and to maintain the specified accuracy. The recommended check and calibration term is once a year and after the repair service. This service is available at KAISE AUTHORIZED SERVICE AGENCY through your local dealer.

4. Software Version Update

- You can update the internal software from our website (<http://www.kaise.com/NewEnglish.htm>) when it is available. Download the file in reference to the loading procedures.

5. Others

- If the metal part of the battery clip is soiled, wipe it off with soft cloth to obtain the accurate measurement.
- If Date and Time are not able to set, internal backup battery is exhausted. Ask KAISE AUTHORIZED SERVICE AGENCY through your local dealer for repair service.

TROUBLE SHOOTING & REPAIR

If there are any failure with this instrument, check the following trouble shoots before asking repair service. Ask KAISE CORPORATION AUTHORIZED SERVICE AGENCY through your local dealer when there are any questions or troubles with this instrument.

Symptoms	Possible Causes and Necessary Treatments
Cannot turn on the instrument	<ul style="list-style-type: none">● Battery Clips are connected in the wrong polarity. → Connect Black clip to minus ⊖ terminal of the battery and Red clip to plus ⊕ terminal of the battery.● Battery voltage is lower than 8V. → Charge the battery.● USB Plug is weakly inserted in USB port when connecting with PC. → Insert USB plug deeply.● Metal part of the battery clip or battery terminal is soiled. → Remove it cleanly.● There in an abnormality in the battery. → Check visually the appearance of the battery; dirt of the terminal, abnormality of the terminal cable, etc.
Cannot save, view and delete data	<ul style="list-style-type: none">● System error is occurring. → Format the Removable Disk in reference to "2. Formatting of Removable Disk" on Page 39.
Cannot be printed out	<ul style="list-style-type: none">● Printer paper is set inversely. → Set it correctly in reference to "1. Printing Paper Setup" on page 37.● Printer is jammed. → Open the Printer Cover and fix that paper jam.
Cannot set Date / Time settings	<ul style="list-style-type: none">● built-in battery for backup is exhausted. → Ask KAISE AUTHORIZED SERVICE AGENCY through your local dealer for repair service.
Error message is displayed	<ul style="list-style-type: none">● Metal part of the battery clip or battery terminal is soiled. → Remove it cleanly.● There in an abnormality in the battery. → Check visually the appearance of the battery; dirt of the terminal, abnormality of the terminal cable, etc.

WARRANTY

SK-8535 is warranted in its entirety against any defects of material or workmanship under normal use and service within a period of one year from the date of purchase of the original purchaser. Warranty service is available at **KAISE AUTHORIZED SERVICE AGENCY** through your local dealer. Their obligation under this warranty is limited to repairing or replacing SK-8535 returned intact or in warrantable defect with proof of purchase and transport charges prepaid. **KAISE AUTHORIZED DEALER** and the manufacturer, **KAISE CORPORATION**, shall not be liable for any consequential damages, loss or otherwise. The foregoing warranty is exclusive and in lieu of all other warranties including any warranty of merchantability, whether expressed or implied.

This warranty shall not apply to any instrument or other article of equipment which shall have been repaired or altered outside of **KAISE AUTHORIZED SERVICE AGENCY**, nor which have been subject to misuse, negligence, accident, incorrect repair by users, or any installation or use not in accordance with instructions provided by the manufacturer.

KAISE AUTHORIZED DEALER

--

KAISE CORPORATION

422 Hayashinogo, Ueda City, Nagano Pref., 386-0156 Japan

TEL : +81-268-35-1601 / FAX : +81-268-35-1603

E-mail : sales@kaise.com <http://www.kaise.com>

Product specifications and appearance are subject to change without notice due to continual improvements.