

INSTALLATION MANUAL

Table of contents

<p>1. Precaution.....1</p> <p>2. Structure and working Principle.....2</p> <p>2.1 Structure Schematic Diagram.....2</p> <p>2.2 Main Structure and Principle of the Equipment.....5</p> <p>3 Tools for installation and adjustment.....5</p> <p>4. Unpacking.....5</p> <p>5. Installation.....5</p> <p>5.1 Important notice.....5</p> <p>5.2 Installation Procedure.....6</p> <p>5.2.1 Selecting installation site6</p> <p>5.2.2 Base plate layout.....7</p> <p>5.2.3 Install the powerside column.....8</p>	<p>5.2.4 Install the top beam.....9</p> <p>5.2.5 Install the offside column.....9</p> <p>5.2.6 Install and adjust the balancing steel cables.....9</p> <p>5.2.7 Install the power unit.....10</p> <p>5.2.8 Connecting the power supply.....10</p> <p>5.2.9 Connecting the hydraulic lines.....11</p> <p>5.2.10 Install the swing arm and guardrail.....12</p> <p>5.2.11 Adjust the steel chain.....12</p> <p>6. Lift Adjustment.....12</p> <p>6.1 Preparation before adjustment.....12</p> <p>6.2 Adjustment procedure.....12</p> <p>7. List of the lift components.....13</p> <p>Diagram of the electrical system.....18</p> <p>Diagram of the hydraulic system.....18</p>
---	---

Appendix 1: two post clear-floor lift special specifications (optional)

Appendix 2: Special steel cables and oil hoses ERP Codes

1 Precaution

Warning



- l This manual is an essential integral part of this equipment. Please read it carefully.
 - l Properly keep this manual for use during the maintenance.
 - l This lift is only used for its clearly designated purpose. Never use it for other purposes.
 - l The manufacturer is not responsible for any damage or injury caused by improper use or use for other purposes.
- ### Precautions for the Installation and Adjustment:
- l Before the installation and adjustment, carefully read this manual and the user's manual. Without the permission of the manufacturer or not following the requirement of the manual, any changes on the machine parts and its usage may cause direct or indirect damage to the machine and injury on operators.
 - l To do the installation and adjustment, the personnel must have certain electrical knowledge.
 - l The operators must undergo special training and are qualified.
 - l Fix and install the lift on the stable concreted floor.
 - l The lift shall be installed in a sufficient space so that the operation is not restricted.
 - l Don't expose the lift to the extreme temperature and humidity environment. Avoid installation beside the heating equipment, water tap, air humidifier or stove.
 - l Don't install the lift in front of the window where the sunlight can shine directly. When it's unavoidable, use curtain to shield the sunlight.
 - l The manufacturer reserves the right to make design changes or add improvements to its product line without notice.
 - l Before installation, carefully check the packing list of lift. In case of any question, please contact the distributor or LAUNCH immediately.

2. Structure and working principles

2.1 Structure Schematic Diagram

The structure of TLT235SC (C) is as shown in Fig. 1.2.3

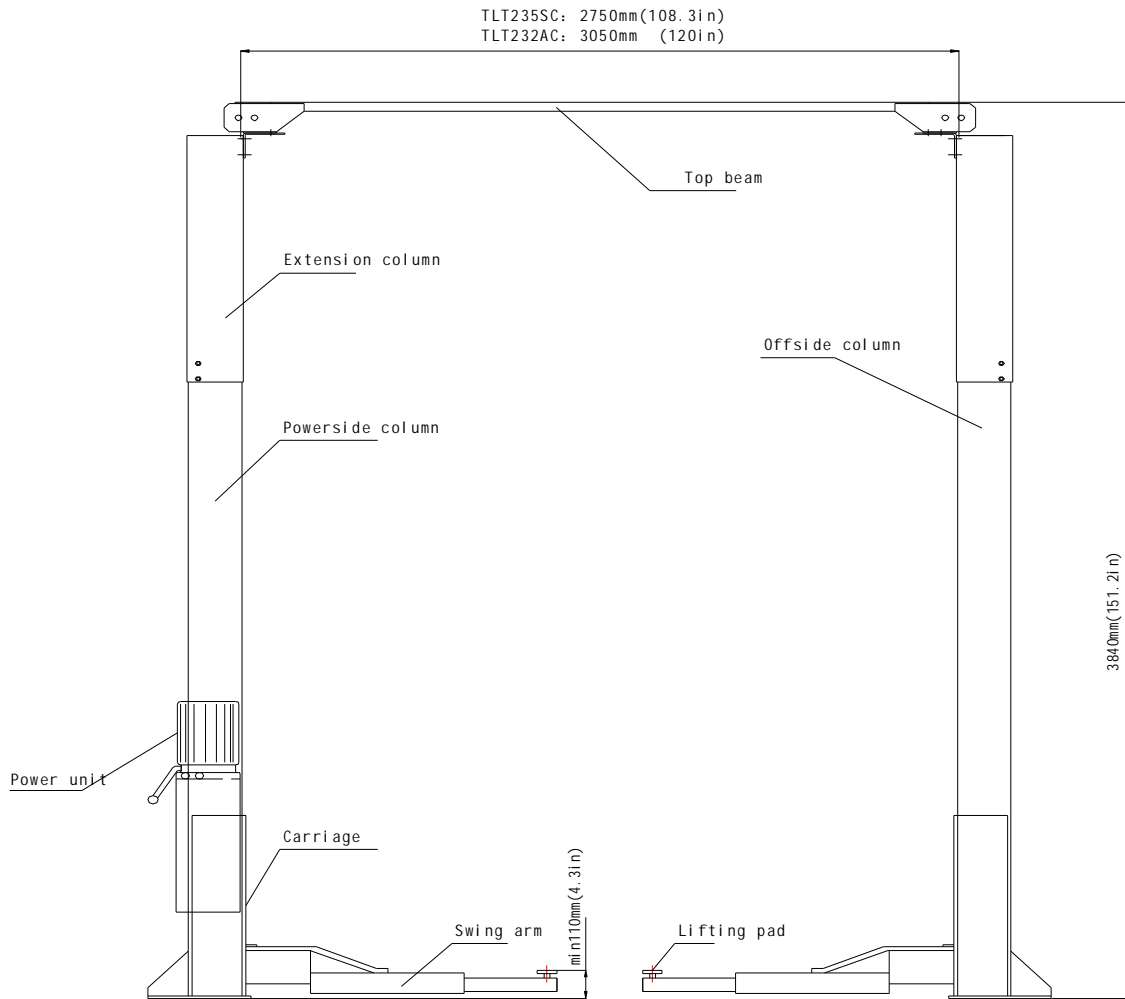

Fig.1

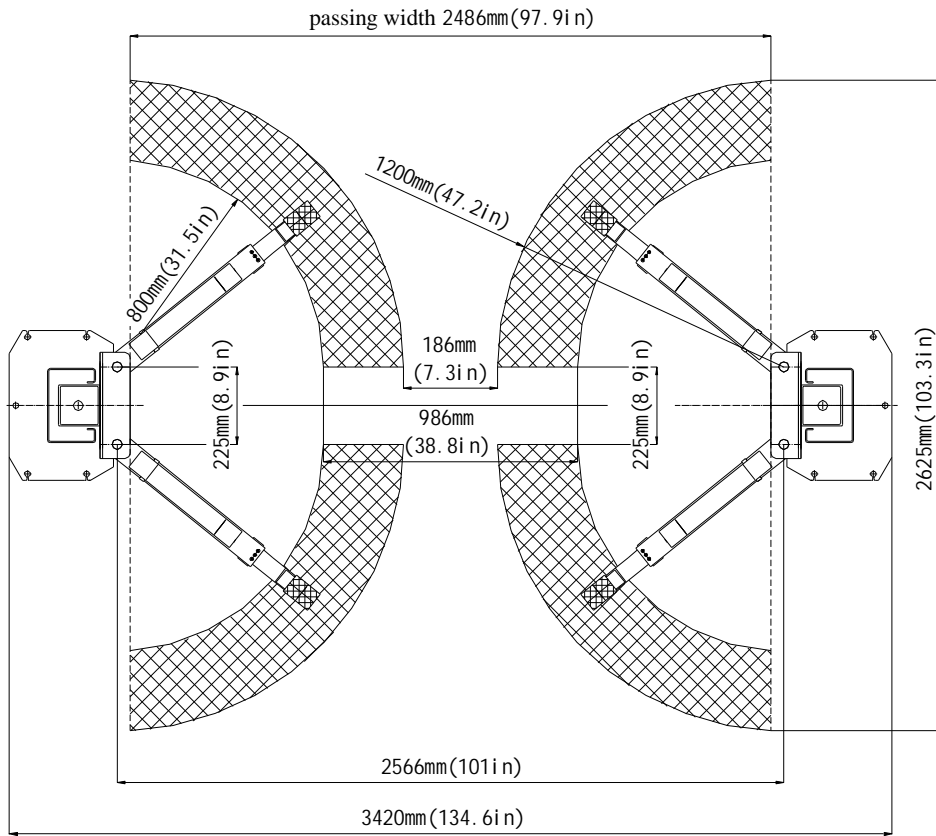

Fig. 2

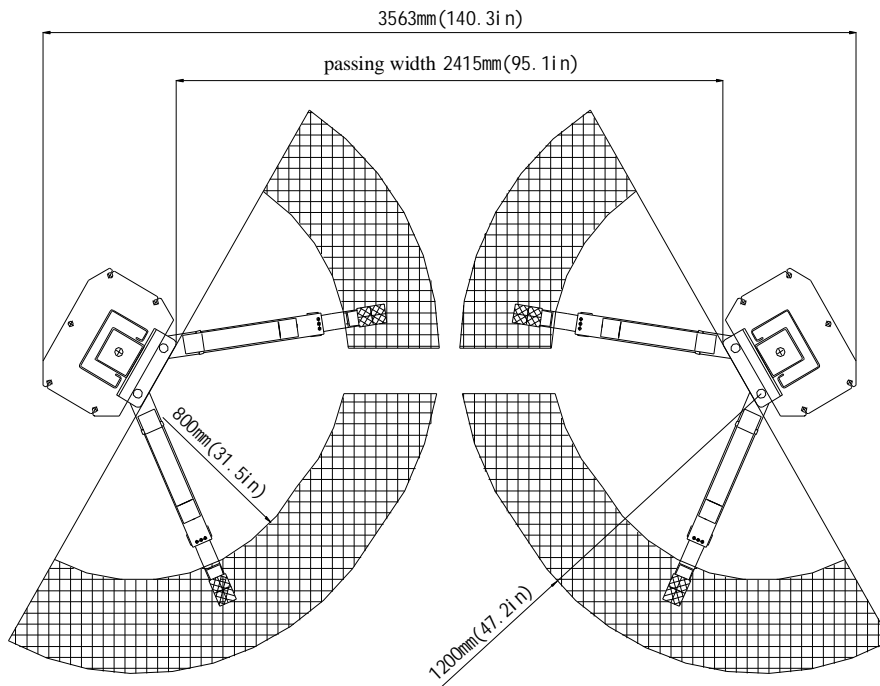

Fig. 3

2.2 Main structure and principles of the equipment

- I Lifting mechanism: Each of the two columns has one hydraulic cylinder respectively. When the power unit works, the hydraulic oil gets into the lower chamber of the cylinder, forcing the piston rod moves upward. At this time, the carriage moves upward through the chain.
- I Supporting mechanism: When the vehicle enters into the working area, adjust the position of two-stage telescopic swing arms to make the lifting pad near the correct lifting point of the vehicle, and then adjust the screw height below the pad to adapt to different heights of vehicle chassis.
- I Balancing mechanism: To keep the balance during the lifting and lowering process, the lift uses two steel cables to interconnect two carriages, forcing the carriages to rise and descend synchronously. If the carriages and swing arms are not on the same level, adjust the screw at the end of the steel cable, making the swing arms at the same level (equal position from the floor). At this time, the steel cables must be adjusted tightly with equal tension, otherwise the equalization can't be ensured.
- I Manual safety locking system: the safety locking plates are installed on the two carriages and the toothed bar plate is welded on the internal wall of the column. During the lifting of the carriage, the safety locking plate goes up against on the toothed bar plate by the tension of spring. When the carriage stops, the safety locking plate opens and then is engaged in the toothed bar slot to ensure the carriage will not go down; when the lowering operation is required, just raise the carriage upward a little to loosen the safety locking plate from the toothed bar slot, and then manually pull the steel wire rope so as to jack up the safety locking plate by sliding plate, so the safety locking is released so that the carriage can be lowered down. Because the manual safety locking systems are installed on the two carriages, double safety protection can be provided; therefore, to disengage the safety locking, the steel rope on the two carriages shall be respectively pulled.
- I To prevent the vehicle slip, the swing arm is installed with positioning mechanism, making the swing arm capable of automatic locking during operation.
- I Safety scope: The safety lock mechanism is effective from the height of lifting pad 450mm to 1900mm.

3. Tools for installation and adjustment

To ensure proper installation and adjustment, please prepare the following tools:

Tool	Model
Leveling instrument	Carpentry type
Chalk line	Min 4.5m
Hammer	1.5kg
Medium crescent wrench	40mm
Open-end wrench set	11mm-23mm
Ratchet socket set	
Flat screwdriver	150mm
Rotary hammer drill	20mm
Concrete drill-bit	∅ 19mm

4. Unpacking

- I Open the packing box; remove the packing materials and inspect the lift for any sign of shipment damage. Check by packing list to see if the main parts and accessories are complete.
- I Keep the packing materials away from the children to avoid danger; if the packing materials cause the pollution, they shall be treated properly.

5. Installation

5.1 Important notice

- I The wrong installation will cause the lift damage or personal injury. The manufacturer will not undertake any responsibilities for any damage caused due to incorrect installation and usage of this equipment, whether directly or indirectly.
- I The correct installation location shall be "horizontal" floor to ensure the horizontal lifting. The slightly slope floor can be corrected by proper shimming. Any big slope will affect the height of the lifting pad when at the bottom or the horizontal lifting. If the floor is of questionable slope, consider a visual inspection, or pour a new horizontal concrete slab if possible. In short, under the optimum horizontal lifting status, the level of the lifting relies on the level of the floor where it is installed. Don't expect to compensate for the serious slope.
- I Don't install this lift on any asphalt surface or any

surface other than concrete. The lift must be installed on concrete conforming to the minimum requirement showed in the manual. Don't install this lift on the concrete with seams or crack and defect. Please check together with the architect.

- I Without the written approval of the architect, don't install this lift on a second floor with basement.
- I Overhead obstruction: The lift installation area can't have any overhead obstruction, such as heater, building support, electrical pipe, etc.
- I Concrete drilling test: The installation personnel can test the concrete thickness at each site by drilling test. If several lifts are installed at one place, it is preferred to make drilling test in each site
- I Power supply: Get ready the power supply before the installation. All the electric wiring and connecting should be performed by a certified electrician.

5.2 Installation procedure

5.2.1 Selecting installation site

Select installation site based on the following conditions:

- I If the thickness of the whole ground concrete is greater than 250mm, the lift can be installed directly.
- I If the thickness of the whole ground concrete is less than 250mm, the concrete slab must be made. The minimum thickness of the concrete slab is 250mm, with 20 days of minimum curing time.
- I The concrete slab shall have steel bar reinforced and must be leveled.
- I Check the possible obstruction, e.g. low ceiling, top pipeline, working area, passage, exit, etc.
- I The front and back of the lift should be reserved with sufficient space to accommodate all the vehicles. (Fig. 4)

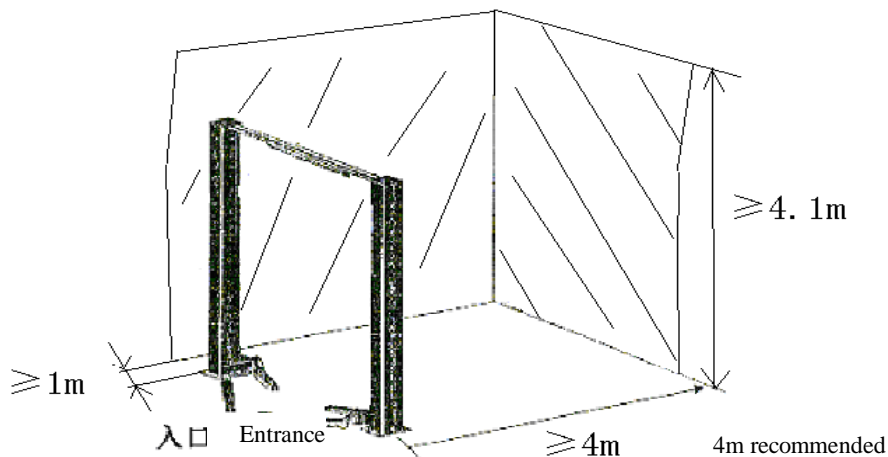

Fig.4

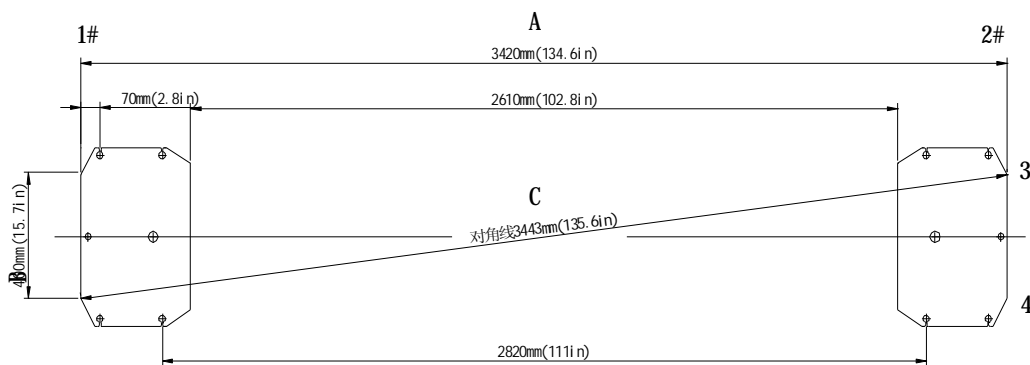

Fig.5

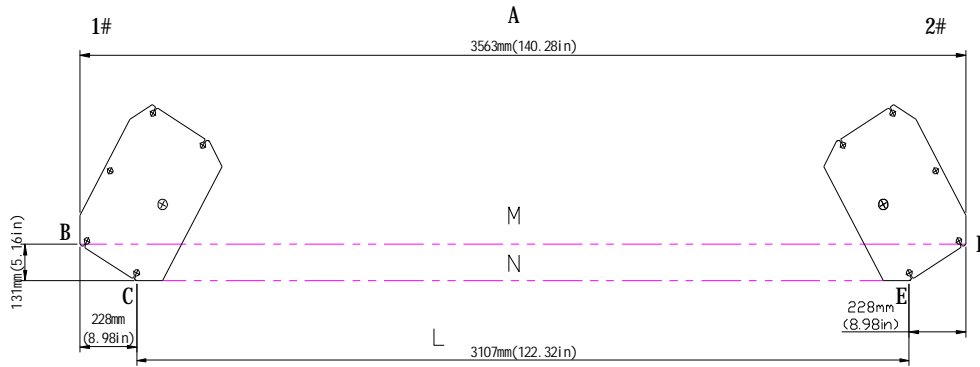

Fig.6

5.2.2 Base plate layout

As shown in Figure 5 (symmetric installation of TLT235SC)

- I With total width (A) as the basis, draw two parallel lines (#1 and #2) on the concrete slab, with the error within 3mm.
- I Determine the powerside column location on any chalk line, and mark the total width (B) of the base plate. Mark the points 3 and 4.
- I Starting from point 3, draw one diagonal line (C) to the point 5 forming a triangle. In this way, the #1 and #2 lines can determine the location of the two columns.

As shown in Figure 6 (asymmetric installation of TLT235SC)



Notes:

- .. All the dimensions are based on the external border of the base plate.

- .. Ensure that the overall errors shall be controlled within 6mm, thus eliminating the difficulty occurring during the final assembly or the early wear or misalignment of the chains.
- .. The marking and layout is very important. If not correct, problems will happen during the final assembly and operation.

5.2.3 Install the powerside column

First connect and assemble the extended column with powerside column, and then raise the powerside column upper right to the location. Align the base plate of column with the chalk line layout. Guided by the hole on the base plate of the column, drill the holes into the concrete slab and use five concrete anchor bolts to fix it onto the ground. During the drilling process, ensure no movement of the column from the chalk line (Fig. 7).

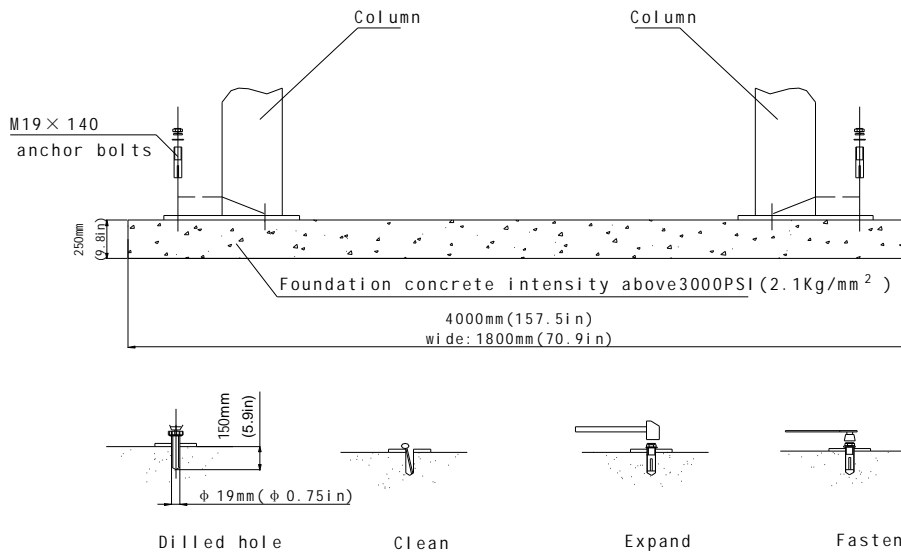

Fig.7

Notes:

- 2 Use sharp F19mm concrete drill-bit to drill the holes. Don't ream the hole or allow the drill to wobble.. Use proper tool to remove the dust from the hole. The depth of the hole is the same as that of the anchor bolt. Insert the anchor bolt and make the washers lean against the base of the column. If shimming is required, enough thread must be left.
- 2 When fastening the anchor bolt, only use the (torque) wrench, and don't use impact tool for fastening.

Insert proper shims under the base of column if necessary, making the column vertical.

Note: The thickness of shims shouldn't exceed 5mm.

To get the correct and safety installation, please follow the following installation steps.

- I Wear the safety goggles.
- I Use hard alloy drill-bit.
- I Don't use the drill-bit with wearing exceeding the tolerance.
- I The drill and concrete surface should be kept

perpendicular.

- I Let the drill work itself. Don't apply the extra force, and don't ream the hole or allow the drill to wobble.
- I The drilling depth of the hole is based on the length of anchor bolt. The distance from the bolt head to the concrete ground should be more than twice of the bolt diameter.
- I Remove the dust from the hole.
- I Gently tap the bolt into the hole, till the washer rests against the base plate of column.
- I Tighten the bolt.

5.2.4 Install the top beam

Position the offside column at the designated chalk location. Lift the top beam to its high position, and use four M12 bolts, washers and lock nuts to fix it with the columns (as shown in Fig. 8). When installing the top beam, ensure the above micro switch support adjacent to the powerside column.

Note: Since the offside column is not secured to the floor by the bolts, you must operate carefully to avoid the falling of the column.

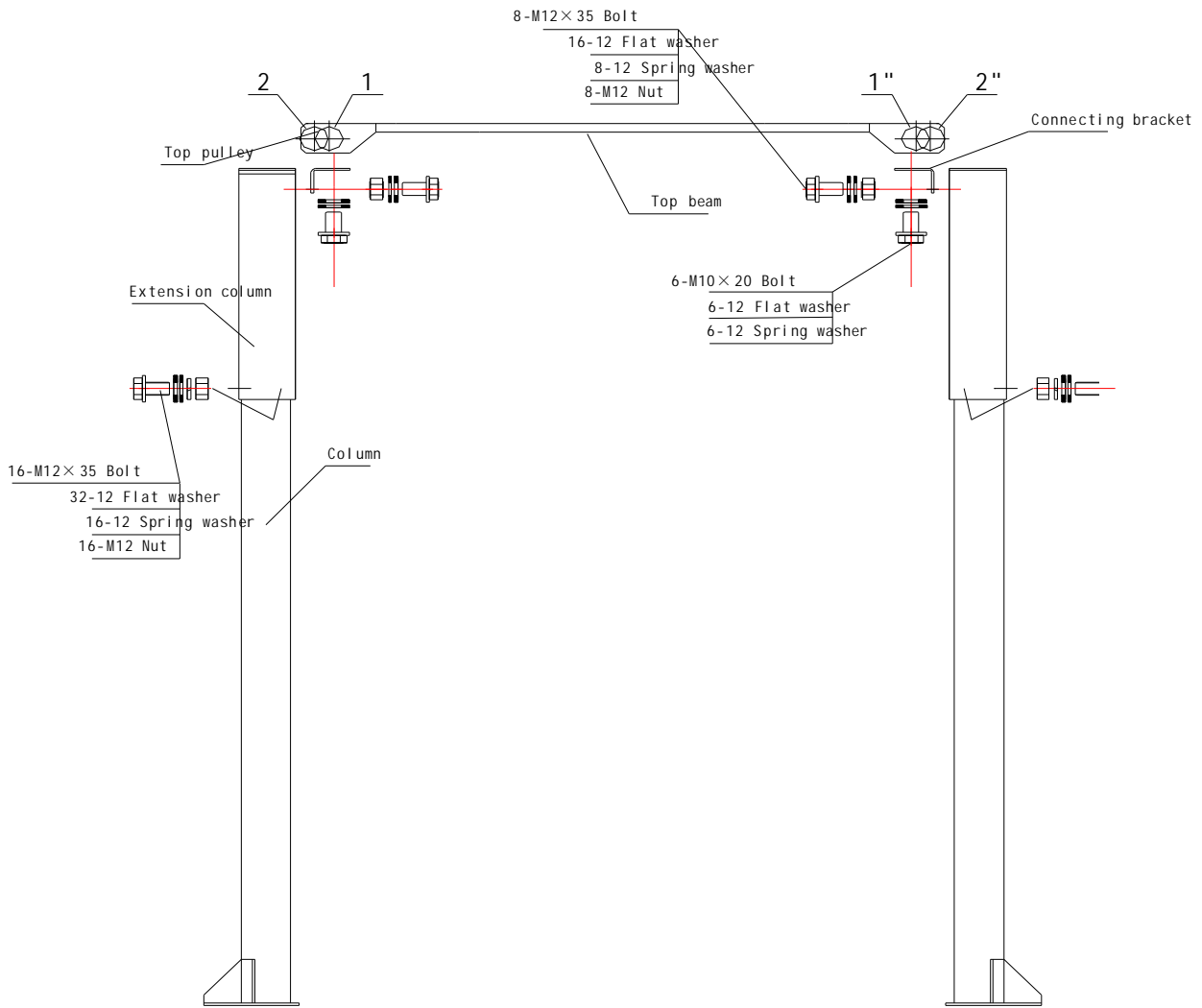

Fig.8

5.2.5 Install the offside column

Drill holes and install the offside column following the same procedures as outlined in 5.2.3

5.2.6 Install and adjust the balancing steel cables

- I Raise the two carriages to the safety locking position (make sure that the safety locks on each column are fully engaged before attempting to install cables), and two carriages are in equal position from the floor (same height). Install the two steel cables as shown in Fig. 9.

- I Adjust the tension of cables through the adjustment nuts on each end of steel cable. The steel cables should be tight in equal tension. Each steel cable should be ensured in the pulley when adjusting tightly, otherwise the steel cable will be damaged..

⚠ Note : Before operating the lift, recheck to balancing steel cables and ensure they are not intersected or wrongly installed. Ensure that the steel ropes are still on the pulley.

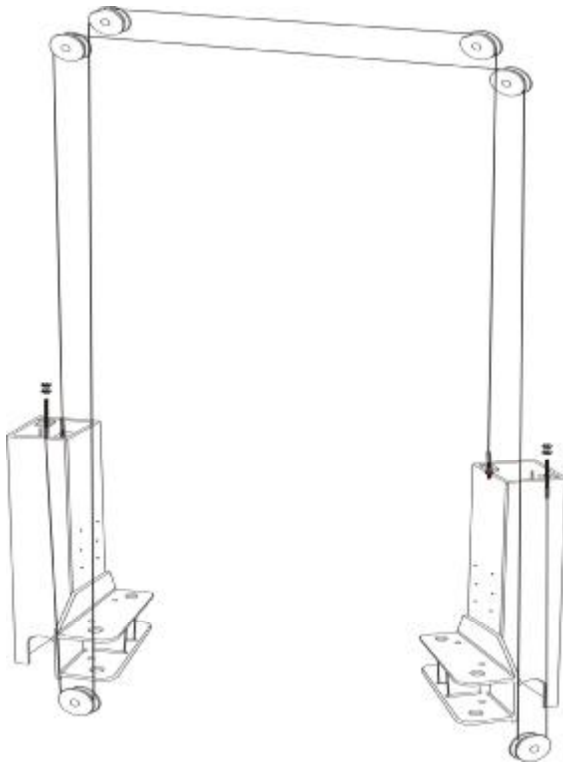

Fig.9

Key points for assembly: the two steel cables shall be adjusted to equal tension in order to ensure the simultaneous movement of the two carriages.

5.2.7 Install the power unit

- 1 Use two M10 bolts and washers (as Fig.10) to secure the power unit. After the securing of the power unit. Fill the reservoir with hydraulic oil (oil capacity of 10L). Operate carefully to avoid dust and other pollutants mixed with the hydraulic oil.

5.2.8 Connecting the power supply (As Fig.11)

Dismantle the sealing cover of the electrical box on the power unit and do the wiring according to the circuit diagram; the power supply switch is required to be installed near the lift for convenient disconnecting the power supply during maintenance or in case of emergency. The motor damage caused by wrong wiring is not warranted. Please contact the manufacturer for the electrical issues. Ensure that the oil tank is full; don't operate where there is no oil. After pressing the start button, if the motor doesn't run or the abnormal noise or heat occurs, the machine shall be immediately stopped to check the correctness of the electrical connections.

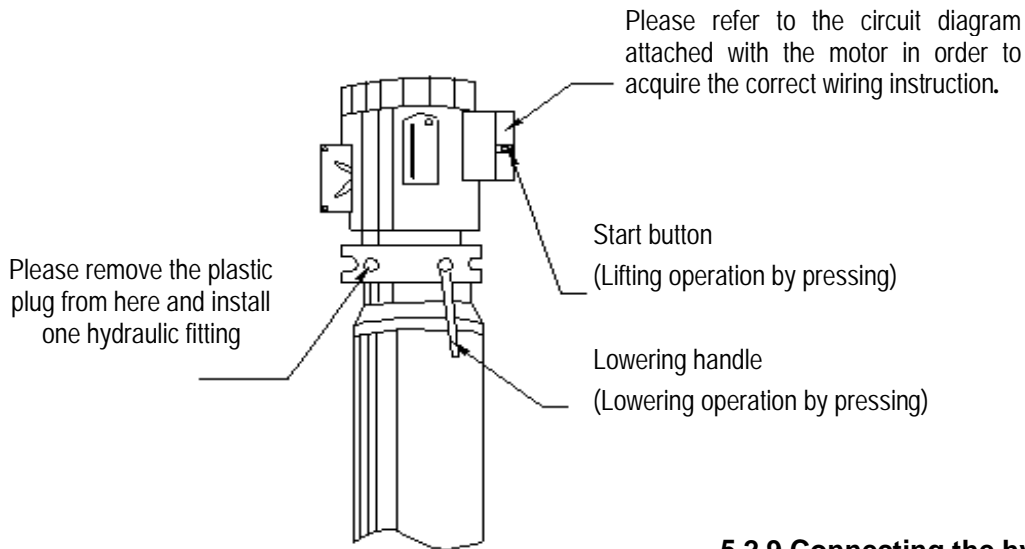

Fig.11



Note:

If the lift is used outdoors, it is recommended to set a cover on the power unit; such damages to the motors caused by the water or other liquids like the detergent, acid, etc, are not covered by warranty.

5.2.9 Connecting the hydraulic lines

TLT235AC hydraulic lines is shown in Fig.10; please perform the connection according to the diagram and all the fittings shall be tightened in order to prevent the oil leakage.



Note: If the hose shall be installed through the column, ensure that the hose passage will not interfere with any moving parts.

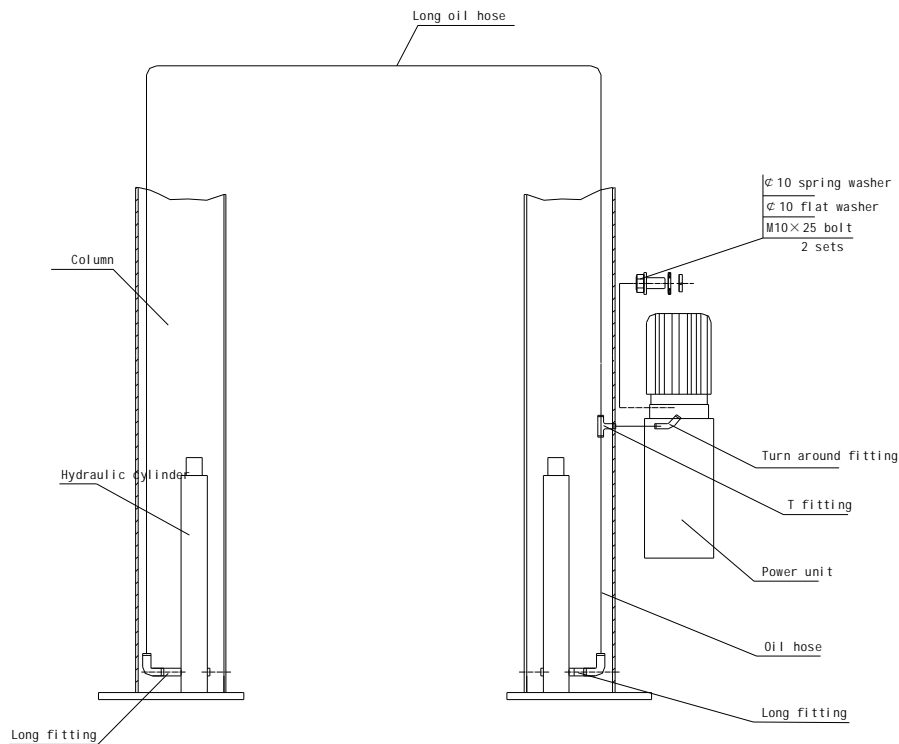

Fig.10

5.2.10 Install the swing arm and guardrail

Install the swing arm, guardrail and door rubber pad as shown in Fig. 12.



Note:

During the installation, lubricate the moving parts of swing arm and carriage if necessary, to ensure the swing arm can move freely.

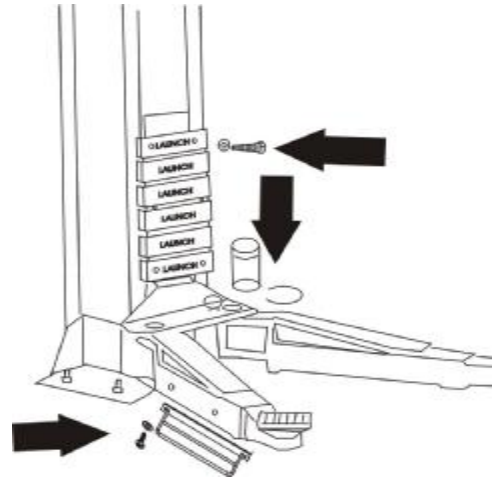

Fig.12

5.2.11 Adjust the steel chain

The steel chain has been adjusted properly by the manufacture (Fig. 13), making the swing arm move freely at the lowest height without scratching the ground. The customer can make fine adjustment for chains after the electrical and hydraulic installation. Before adjustment, lift the carriage to a high position and lower for 2 sec to engage safety lock, and then adjust the nut on the threaded end of the chain to the required position.

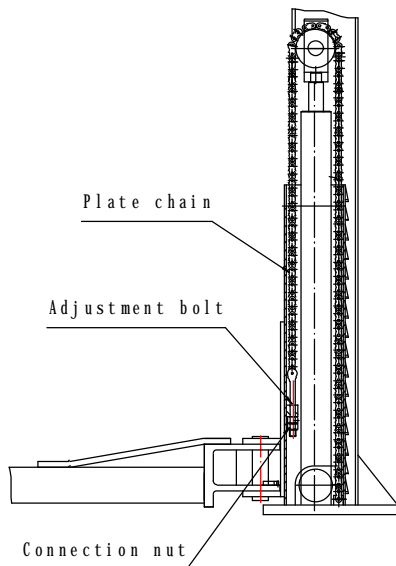

Fig.13

6. Lift adjustment

6.1 Preparation before the

adjustment

- I Lubricate contact surface of the carriage and corners of column with general-purpose lithium grease. All sliding surface should be coated evenly from top to bottom.
- I Fill hydraulic oil N32 or N46 to the oil reservoir of the power unit.

6.2 Adjustment procedure

- I Check to see if the power supply is installed properly.
- I Check for the tightness of all the connecting bolts.
- I Press the starting button on the motor, and the carriage rises; stop pressing the button, then the carriage will stop. In order to lower down the carriage, first pull the steel rope for the safety locks on the two carriages one time for each. In case of failure to pull the wire, re-pull after raising carriage a little. Press the lowering handle on the power unit and the carriage will be lowered; stop pressing the handle, then the carriage will stop. In case of vehicle repairing, when the vehicle is lifted up to the required height, first press the oil release handle to actuate the mechanical safety lock in order to ensure the safety operation.
- I The hydraulic system may contain air due to new installation, to bleed the air, repeat the lifting and lowering for several time
- I The adjustment is completed

7. List of the lift components

This list is only used as information for the maintenance and repair. Our company will not be liable for other uses. In case of damages to the components, purchase can be made from

the LAUNCH and its distributors base on the corresponding parts code No in the list.

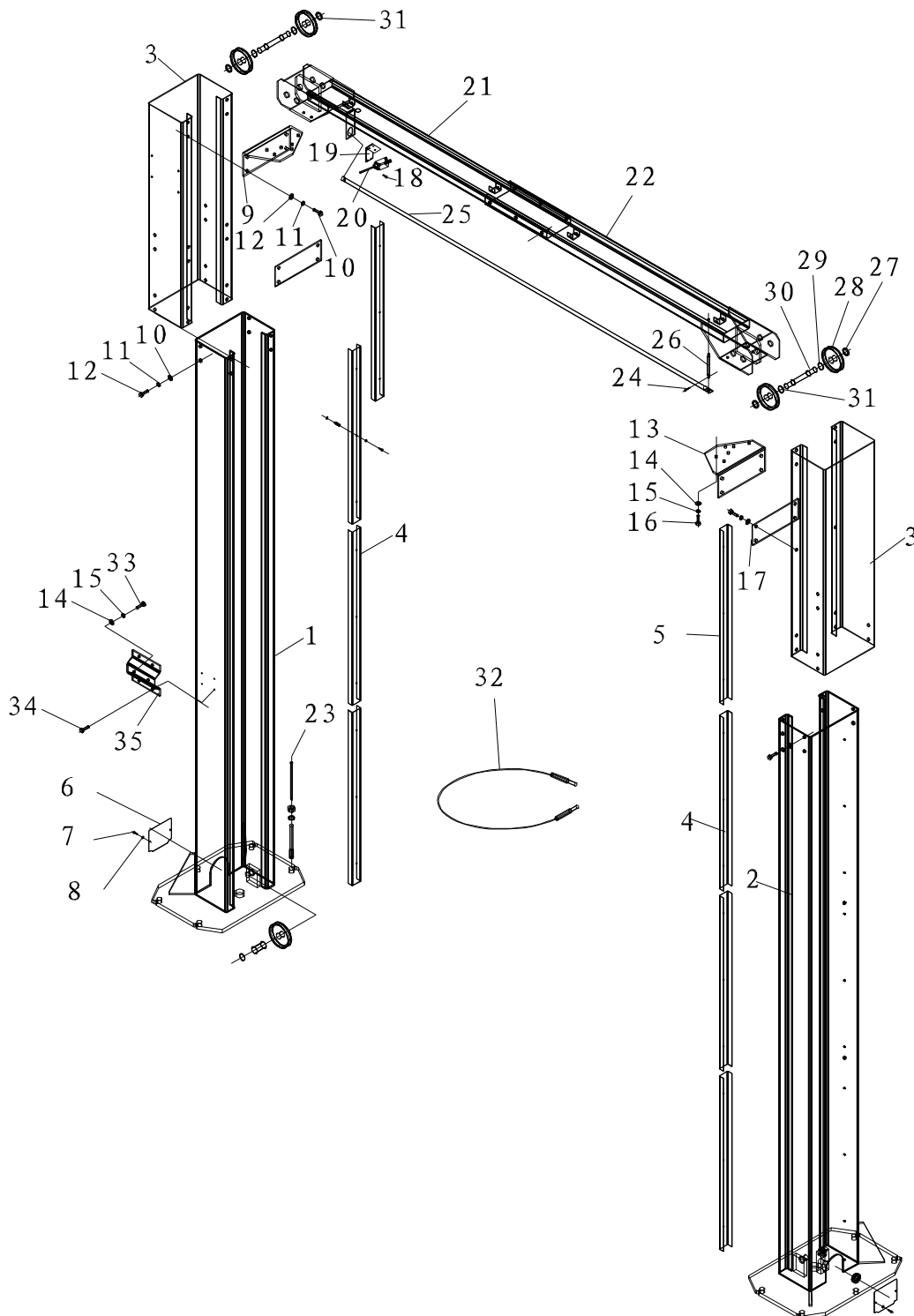

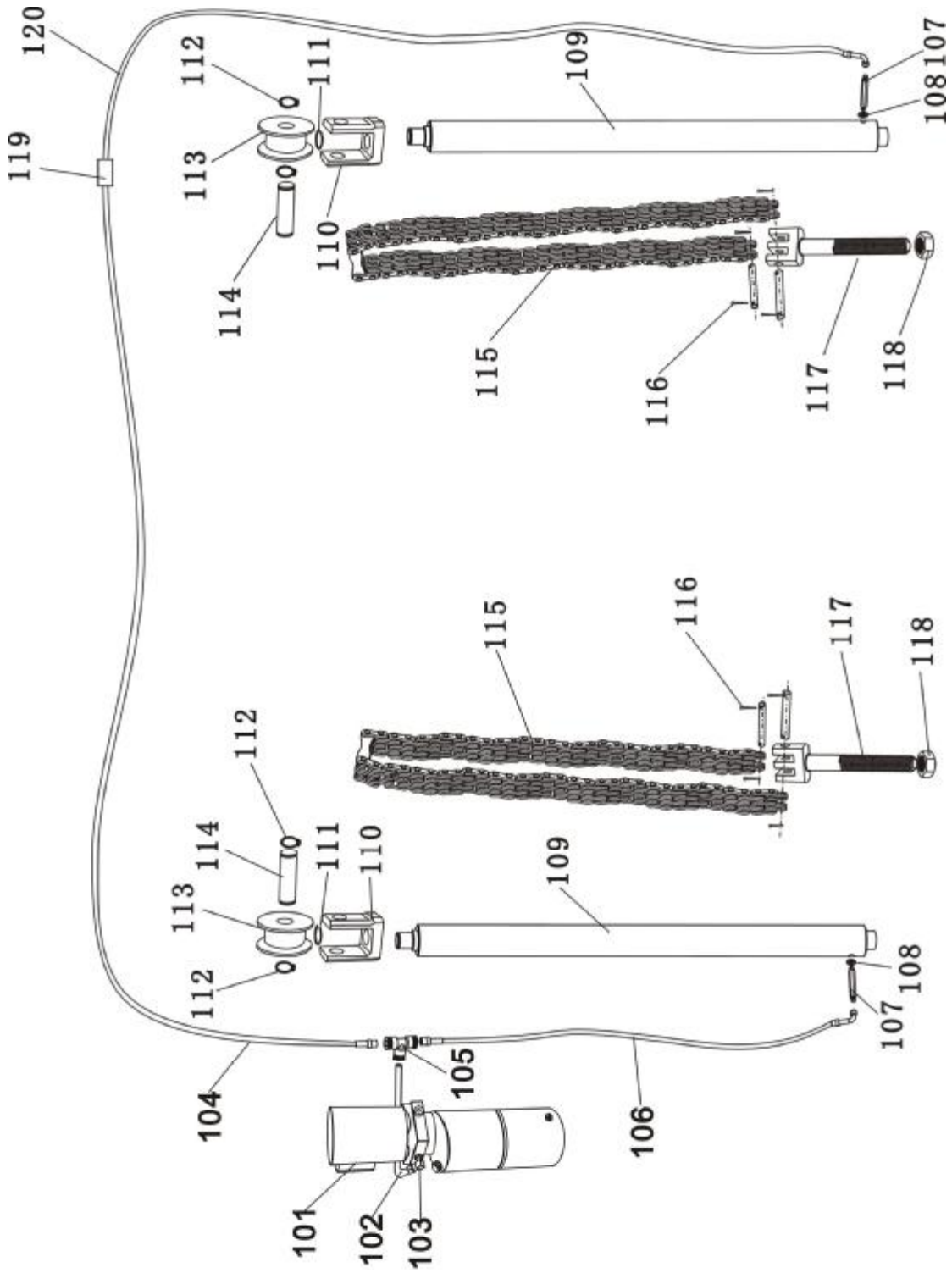

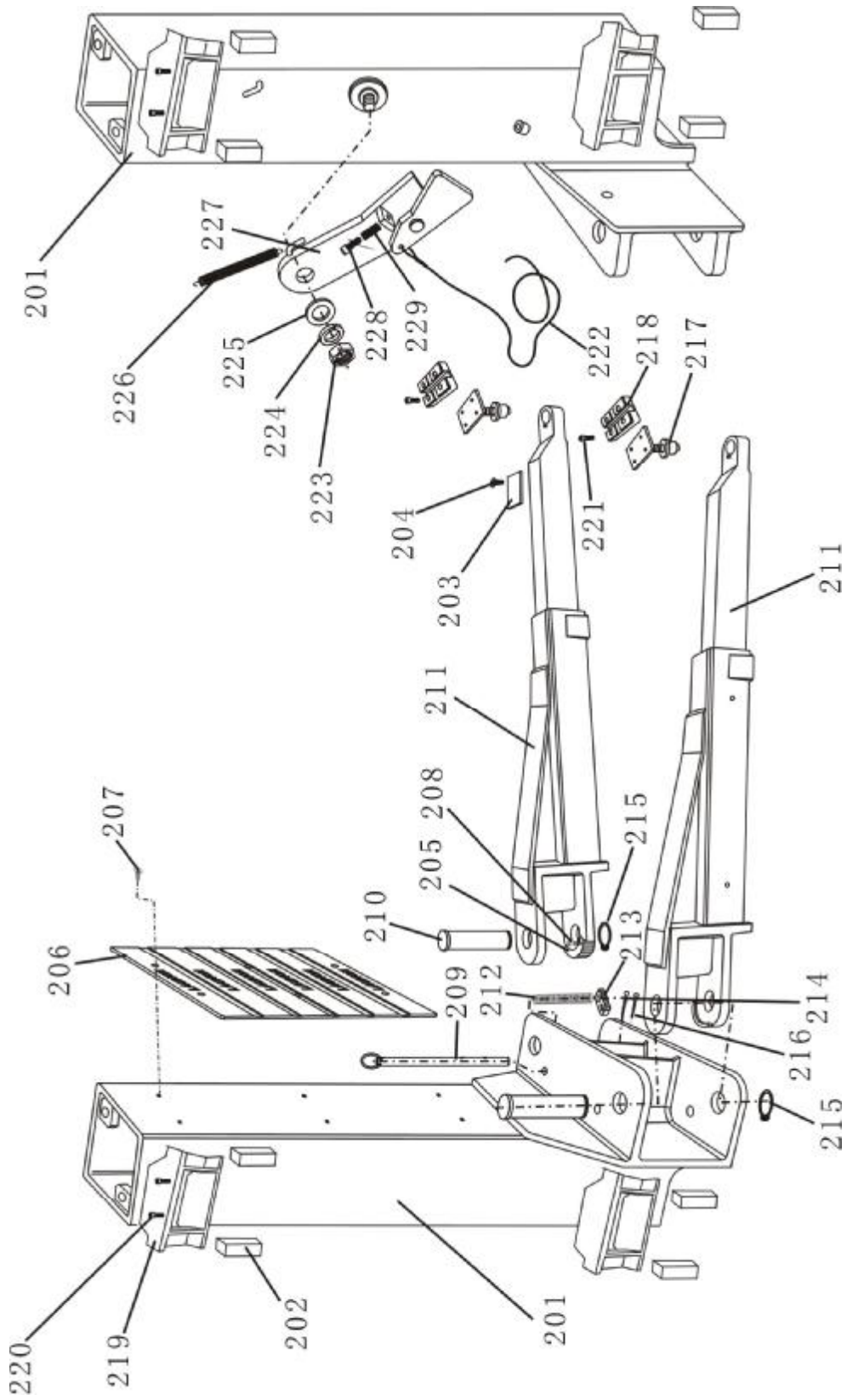

No.	Code	Name
1	201020537	Powerside column
2	201020536	Offside column
3	201020928	Extension column
4	201011806	Protective cover inside the column
5	201011152	Protective cover on the extension column
6	103201070	Protect cover below the column
7	103010432	Screw M5×12
8	103040132	Flat washer 5
9	201011179	Connecting bracket I
10	103020104	Bolt M12×35
11	103040110	Flat washer 12
12	103040044	Spring washer 12
13	201011180	Connecting bracket II
14	103040123	Flat washer 10
15	103040122	Spring washer 10
16	103020120	Bolt M10×20
17	201011176	Reinforced plate
18	103010429	Screw M4×25
19	201011186	Bracket
20	102100075	Limit switch
21	201020530	Inner top beam
22	201020531	Outer top beam
23	103020123	Expanded bolt M18×160
24	103060342	Pin 3X26
25	201011170	Long bar
26	201011172	Support pin for long bar
27	201011257	Bushing II
28	104090045	Pulley
29	103050035	Returning ring 25
30	103200967	Symmetric axle
	103200966	Asymmetric axle
31	201011258	Bushing I
32	101020186	Steel cable
33	103020038	Bolt M10×25
34	103020171	Screw M6×12
35	201011165	Bracket Of power unit
101		Manual power unit
102	104120083	High pressure oil hose L=250
103	103100152	Turn around fitting M14×1.5
104	104120096	High pressure oil hose L=5370
105	103100172	T fitting
106	104120116	High pressure oil hose L=930

107	103100257	Long fitting
108	103040157	Seal gasket 14
109	103260129	Sub cylinder
110	201012356	Sheave seat
111	104060016	Returning ring 32
112	103050014	Returning ring 30
113	X201020388	Sheave
114	103201883	Sheave axle
115	103200939	Steel chain
116	X103060340	Pin 2×26
117	103200938	Chain threaded end
118	103030131	Nut M16
119	103100198	Fitting
120	104120118	Oil hose on offside column
201	201020581	Carriage
202	104990132	Sliding block
203	104130186	Rubber pad on arm
204	103010414	Screw M5X8
205	103201746	Semi-gear
206	104130191	Door rubber pad
207	103010452	Screw M8×16
208	103010354	Screw M8×25
209	103200979	Top rod assembly
210	201010982	Pin axle
211	201021194	Swing arm
212	103110063	Spring
213	201011812	Gear block
214	103060346	Pin 5X40
215	103050030	Returning ring 40
216	103060342	Pin 3×26
217	201021192	lifting pad assembly
218	104130189	Rubber pad
219	201011855	Top cover
220	103010473	Screw M10x30
221	103020093	Screw M8x16
222	201020500	Steel cable
223	103030131	Nut M16
224	103040159	Spring washer 16
225	103040136	Flat washer 16
226	103110061	Spring
227	103200981	Safety block
228	103010471	Screw M8x40
229	103110060	Spring

Diagram of electrical system for Single-phase motor

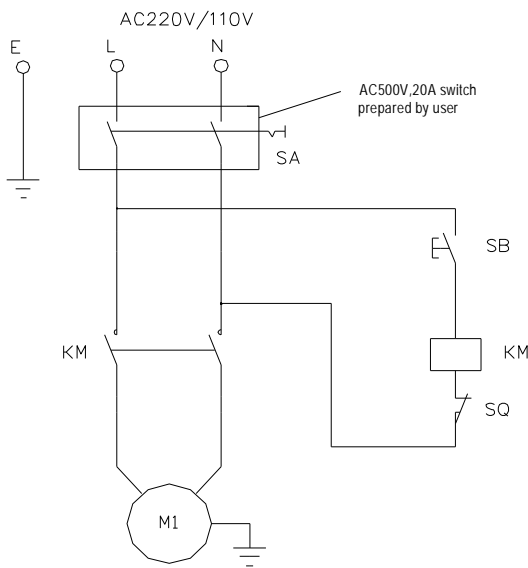

KM-AC Contactor; M-Motor; SB1-pushbutton ,
SQ-Limited Switch

Diagram of electrical system for three-phase motor

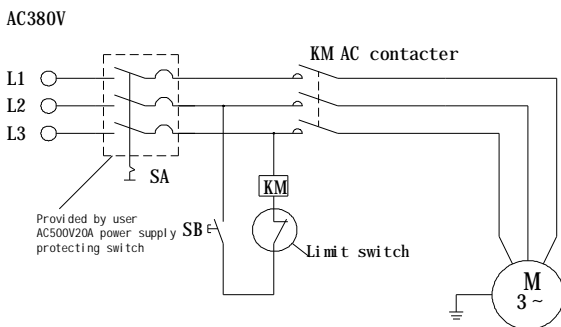

KM-AC Contactor; M-Motor; SB-pushbutton ,

The electrical working principle is as follows:

Press the start button (SB), and the contactor (KM) will be closed; motor (M) is energized to drive the gear pump for oil supply so as to push the carriage upward; release the start button, and the contactor (KM) is open, then the motor (M) will lose the power, so the carriage will stop lifting. As for the clear-floor lift, if the vehicle is lifted up to the top and contacts the limit switch (SQ) on the top beam, the contactor (KM) is released, then the motor (M) will lose the power, so the carriage will stop rising.

Diagram of hydraulic system

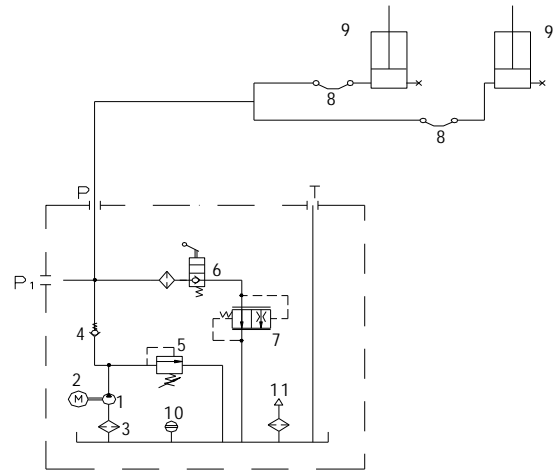

1-gear pump, 2-motor, 3-oil filter, 4-check valve, 5-safety valve, 6-manual lowering valve, 7-Sevo valve, 8-hose, 10-lifting cylinder, 11-level gauge, 12-air filter

Working principles of hydraulic system:

When the button is pressed to start the motor on the power unit, the motor 2 will be actuated to put the oil pump 1 into motion; and oil will be sucked from the oil tank and sent to cylinder 10 forcing the piston move upward. At this time, the safety vale 5 is at the "Closed" position. (The pressure is well adjusted before leaving the factory to ensure the rated capacity. However, when the system pressure exceeds the limit, the oil will automatically overflow). When the start button is released, the oil supply will stop so as to stop the lifting operation. For lowering the carriage, first start up the motor to raise the carriage a little, pull the steel ropes on the two carriages to disengage the safety locking status; and then press the manual lowering handle valve 6 to lower the carriage.