

# **CP93**

**DUAL AC CONTROLLER**

Product Code: 1079

## **INSTALLATION MANUAL**

**Latest Revision: 17.12.2004**  
**Document Ref. No. 1079.D.01.0001\_3**



**CENTURION**  
**THE AUTOMATIC CHOICE**

# Company Profile

---

CENTURION SYSTEMS has been manufacturing automatic gate systems since 1987, and is committed to providing reliable, cost effective solutions in the field of access automation.

CENTURION strives to give service and backup second to none. Our engineers are available to give sales support, installation training, and answers to technical or installation problems.

The equipment is installed worldwide and is available through a network of distributors.

CENTURION is an ISO 9001 registered company, continually looking at updating its products in line with world trends to ensure that its products will provide customer satisfaction.

Further information is available on our web site [www.centsys.co.za](http://www.centsys.co.za)

Centurion Systems (Pty) Ltd. reserves the right to make changes to the products described in this manual without notice and without obligation of Centurion Systems (Pty) Ltd. to notify any persons of any such revisions or changes. Additionally, Centurion Systems (Pty) Ltd. makes no representations or warranties with respect to this manual.

No part of this document may be copied, stored in a retrieval system or transmitted in any form or by any means electronic, mechanical, optical or photographic, without the express prior written consent of Centurion Systems (Pty) Ltd.



# Table of Contents

---

Important Safety Instructions . . . . .	4
Fast Track . . . . .	5
General Description . . . . .	7
Specifications . . . . .	7
Product Identification . . . . .	9
Required Tools & Equipment . . . . .	10
Site Considerations . . . . .	11
Cabling Requirements . . . . .	13
Controller Installation . . . . .	14
Electrical Set-up . . . . .	15
Connections Terminal Functions & Descriptions . . . . .	15
Terminal Identification and numbering . . . . .	16
Motor and Limit Switch Connections . . . . .	18
Radio and Intercom Connections . . . . .	19
Solenoid/Magnetic Lock . . . . .	20
Infra-Red Beams . . . . .	22
Pedestrian Keyswitch and Free Exit Loop . . . . .	23
Status Led and Pillar/Courtesy Lamp(s) . . . . .	24
Pillar Light Control and Emergency Stop Button (Optional) . . . . .	25
Beam 1 Input Configuration for Centrifugal Contact Motors . . . . .	26
Programming . . . . .	27
Orientation in the CP93 Programming Interface . . . . .	27
Basic Programming Menu Navigation . . . . .	27
Programmable Options of the CP93 . . . . .	30
Programming Each Menu Item . . . . .	33
Programming Notes . . . . .	55
Appendix . . . . .	61
Appendix A . . . . .	61
Appendix B . . . . .	62
Appendix C . . . . .	63

# Important Safety Instructions

## **⚠ ATTENTION**

To ensure the safety of people, it is important that you read all the following instructions. Incorrect installation or incorrect use of the product could cause serious harm to people.

The installer, being either professional or DIY, is the last person on the site that can ensure that the operator is safely installed, and that the whole system can be operated safely.

## WARNINGS FOR THE INSTALLER

1. CAREFULLY READ AND FOLLOW ALL INSTRUCTIONS before beginning to install the product.
2. All installation, repair, and service work to this product must be done by a suitably qualified person.
3. Do not activate your gate opener unless you can see it and can determine that its area of travel is clear of people, pets, or other obstructions.
4. NO ONE MAY CROSS THE PATH OF A MOVING GATE. Always keep people and objects away from the gate and its area of travel.
5. NEVER LET CHILDREN OPERATE OR PLAY WITH THE GATE CONTROLS, and do not allow children or pets near the gate area.
6. Secure all easily accessed gate opener controls in order to prevent unauthorized use of the gate.
7. Do not in any way modify the components of the automated system.
8. Do not install the equipment in an explosive atmosphere: the presence of inflammable gas or fumes is a serious danger to safety.
9. Before attempting any work on the system, cut electrical power and disconnect the batteries.
10. The mains power supply of the automated system must be fitted with an all-pole switch with contact opening distance of 3mm or greater. Use of a 5A thermal breaker with all-pole circuit break is recommended.
11. Make sure that an earth leakage circuit breaker with a threshold of 30mA is fitted upstream of the system.
12. Never short circuit the battery and do not try to recharge the batteries with power supply units other than that supplied with the product, or by Centurion Systems.
13. Make sure that the earthing system is correctly constructed, and that all metal parts of the system are suitably earthed.
14. Safety devices must be fitted to the installation to guard against mechanical movement risks such as crushing, dragging and shearing.
15. It is recommended that at least one warning indicator light be fitted to every system.
16. Always fit the warning signs visibly to the inside and outside of the gate.
17. The installer must explain and demonstrate the manual operation of the gate in case of an emergency, and must hand the User/Warnings guide over to the user.
18. Explain these safety instructions to all persons authorized to use this gate, and be sure that they understand the hazards associated with automated gates.
19. Do not leave packing materials (plastic, polystyrene, etc.) within reach of children as such materials are potential sources of danger.
20. Dispose of all waste products like packaging materials, worn out batteries, etc, according to local regulations.
21. **Always check** the obstruction detection system, and safety devices for correct operation.
22. Centurion Systems does not accept any liability caused by improper use of the product, or for use other than that for which the automated system was intended.
23. This product was designed and built strictly for the use indicated in this documentation. Any other use, not expressly indicated here, could compromise the good condition/operation of the product and/or be a source of danger.
24. Everything not expressly specified in these instructions is not permitted.

## **⚠ WARNING**

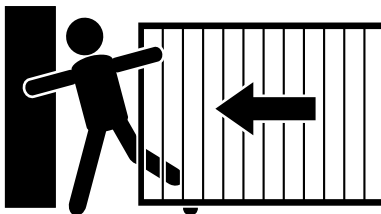

### **MOVING GATE CAN CAUSE SERIOUS INJURY OR DEATH**

KEEP CLEAR. GATE MAY MOVE AT ANY TIME. DO NOT ALLOW CHILDREN TO PLAY IN AREA OR OPERATE GATE .

The following steps are provided for experienced installers and serve as a checklist to get the product up and running in the minimum amount of time. More details are referred to in later sections in the manual.

## ***Mechanical Setup***

<i>Action</i>		
<b>Step 1</b>	<b>Read and understand all safety instructions</b>	<b>Page 4</b>
<b>Step 2</b>	<b>Gather required tools and equipment.</b>	<b>Page 10</b>
<b>Step 3</b>	<b>Heed necessary site considerations.</b>	<b>Page 11</b>
<b>Step 4</b>	<b>Check cabling requirements.</b>	<b>Page 13</b>
<b>Step 5</b>	<b>Mounting the card into the enclosure</b>	<b>Page 14</b>

## ***Electrical Setup***

<i>Action</i>		
<b>Step 5</b>	<b>Making Electrical Connections.</b>	<b>Page 15</b>
<b>Step 6</b>	<b>Initial Programming.</b>	<b>Page 26</b>
<b>Step 7</b>	<b>Configuring limit Switches.</b>	<b>Page 33</b>
<b>Step 8</b>	<b>Configuring Safety Devices.</b>	<b>Page 41</b>
<b>Step 9</b>	<b>Programming Mode of Operation.</b>	<b>Page 36</b>
<b>Step 10</b>	<b>Configuring the leaf order.</b>	<b>Page 45</b>
<b>Step 11</b>	<b>Programming operator run times.</b>	<b>Page 48</b>

# General Description

The CP93 Dual AC controller is a controller card designed to control a pair of gates driven by AC induction motors in various configurations.

The product is designed to allow full control of a set of double swing gates that interleave, irrespective of the operator, and with, or without the use of limit switches. Parameters such as the leaf delay, and leaf order are fully programmable in addition to numerous other standard features such as the run time, reversal delay and general mode of operation.

The CP93 comes complete with an Installer User Interface (or "Installer UI", for short) that allows full customization of the various programming features, easily and in a very straightforward manner.

This is the key feature of the product that allows the installer to rapidly make changes to operating modes and various parameters of the card, in the field and without using other extensive methods. Thanks to this extensive programming feature, the product may be used as a replacement for other brands of controller card.

The installer UI consists of three push buttons and a three-digit, seven segment LED display. The three buttons, namely UP, DOWN and ENTER allow full access to over 23 menu items and sub-menus. Each menu item corresponds to a particular setting of the card, which may easily be selected and adjusted within seconds, saving valuable installation time.

The product provides a means to resolve relay contact arcing, which is a common problem when using relays to control AC induction motors. Each relay has a PF setting which allows the installer to optimize the switching time of the relay such that the card will endeavour to make or break relay contacts when the motor current is tending, or close to zero. In this way it is possible to "tune out" contact arcing problems and allows the use of any kind of AC motor without detriment to the CP93. A factory default setting is provided which is sufficient in most cases, but, for those demanding installations, these settings are fully adjustable by the installer. The CP93 occupies a relatively compact footprint and easily retrofits into most existing enclosures.

## Specifications

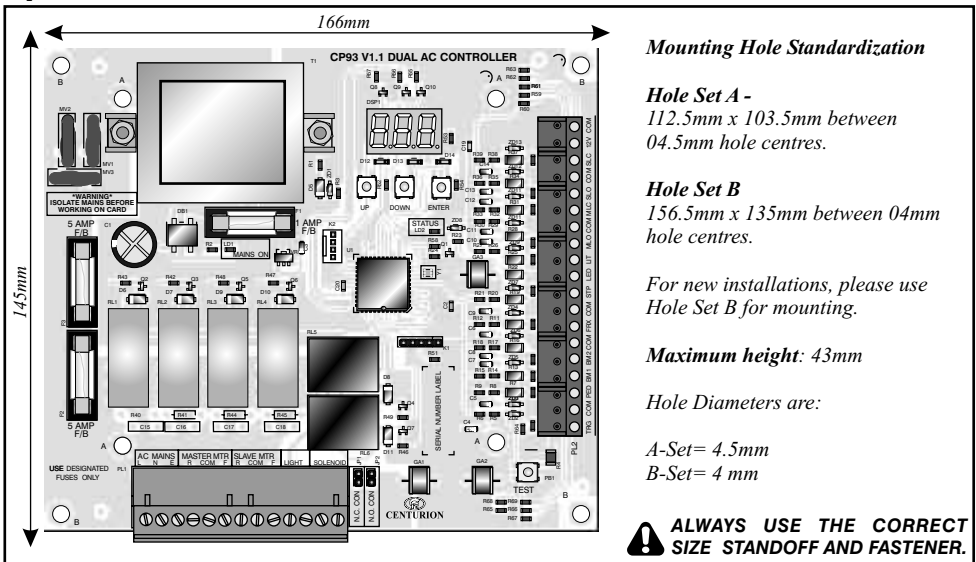

Figure 1 Overall Dimensions

## SPECIFICATION

### ELECTRICAL

Supply Voltage	AC 230V 50/60Hz 10%
Switching Capacity	Max. 5AMP per relay contact at rated voltage and power factor.
Auxillary Relay (Solenoid and Lamp) switching capacity	10 AMP max with a 24-volt AC/DC solenoid 100 watts max. Lamp wattage at 230V AC
Power Consumption in Standby	Approximately 5.5 VA
Auxillary Supply Output Voltage	12-15,2 V DC (max.) unregulated
Max. Allowable current draw on Auxillary Supply	300mA (0,3 AMP)
Replacement Fuses	<b>F1 -</b> 1 AMP Fast blow glass cartridge 5 x 20mm <b>F2, F3 -</b> 5 AMP Fast blow glass cartridge 5 x 20mm

### MECHANICAL

Card Dimensions	166 mm x 145 mm $\pm$ 0.4 mm
Mounting Hole Diameters- Hole Set A: Hole Set B:	112.5mm x 103.5mm between 4.5mm hole centres 136.5mm x 135mm between 4mm hole centres

### ENVIRONMENTAL

Operating Temperature Range	-50 °C to +55°C
Relative Humidity (RH) non-condensing	20 - 80 %

### OTHER SPECIFICATIONS

Recommended Electric (solenoid) lock	12-24V AC or DC solenoid lock powered from a separate power source such as a transformer. <b>Warning:</b> Do not attempt to supply power to lock from the 12V auxillary supply! The card will malfunction resulting in possible damage to the card and the gate operators.
Recommended Courtesy lamp	100 watts maximum incandescent. To operate larger lamps use a contactor or additional relay.
Recommended Enclosure	Plastic enclosure rated to IP 56. Internal metal baseplate is preferred and must be earthed.



# Product Identification

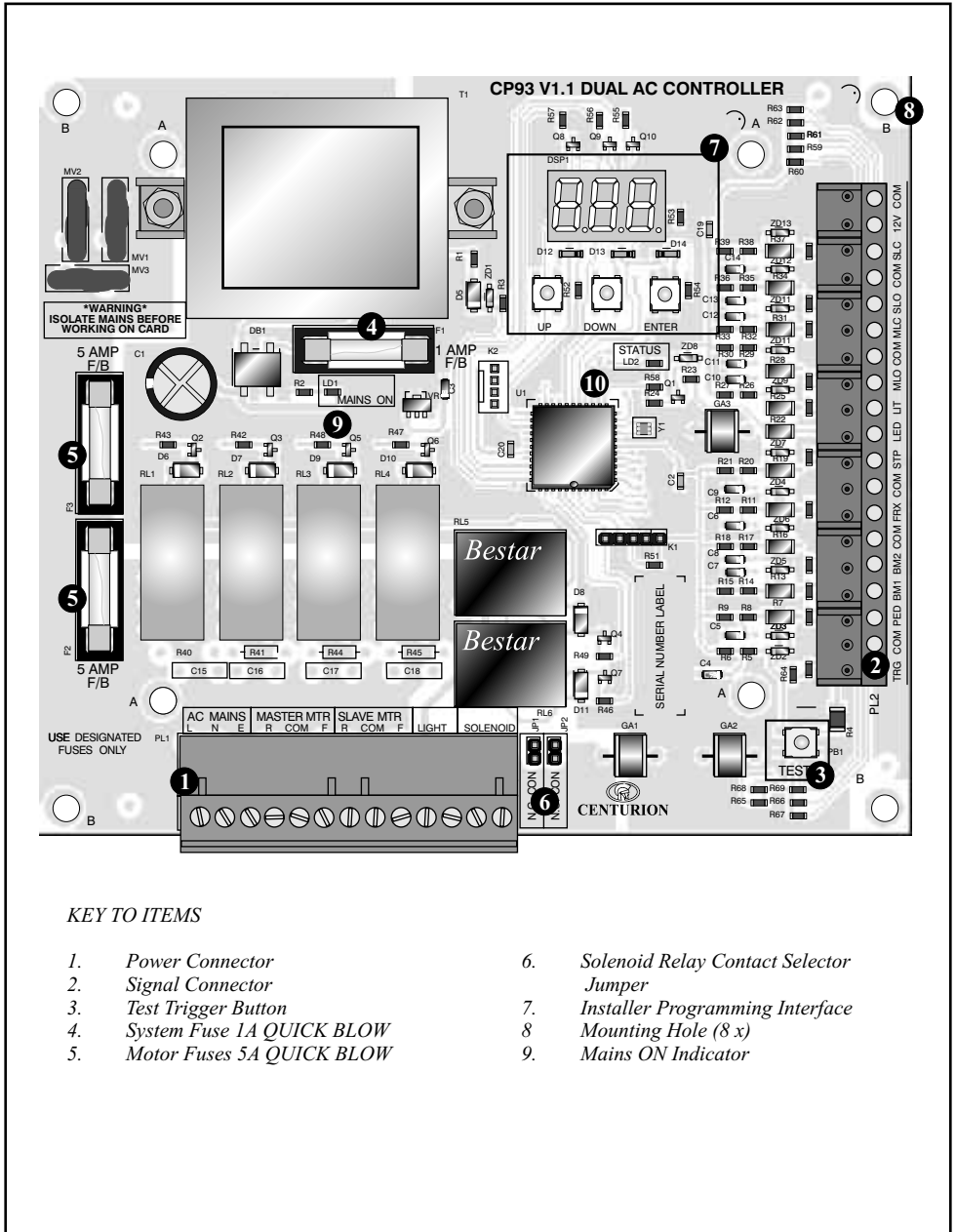

## KEY TO ITEMS

- |                              |   |
|------------------------------|---|
| 1. Power Connector           | 6. Solenoid Relay Contact Selector Jumper |
| 2. Signal Connector          | 7. Installer Programming Interface        |
| 3. Test Trigger Button       | 8. Mounting Hole (8 x)                    |
| 4. System Fuse 1A QUICK BLOW | 9. Mains ON Indicator                     |
| 5. Motor Fuses 5A QUICK BLOW |   |

Figure 2 Product Identification

# Required Tools & Equipment

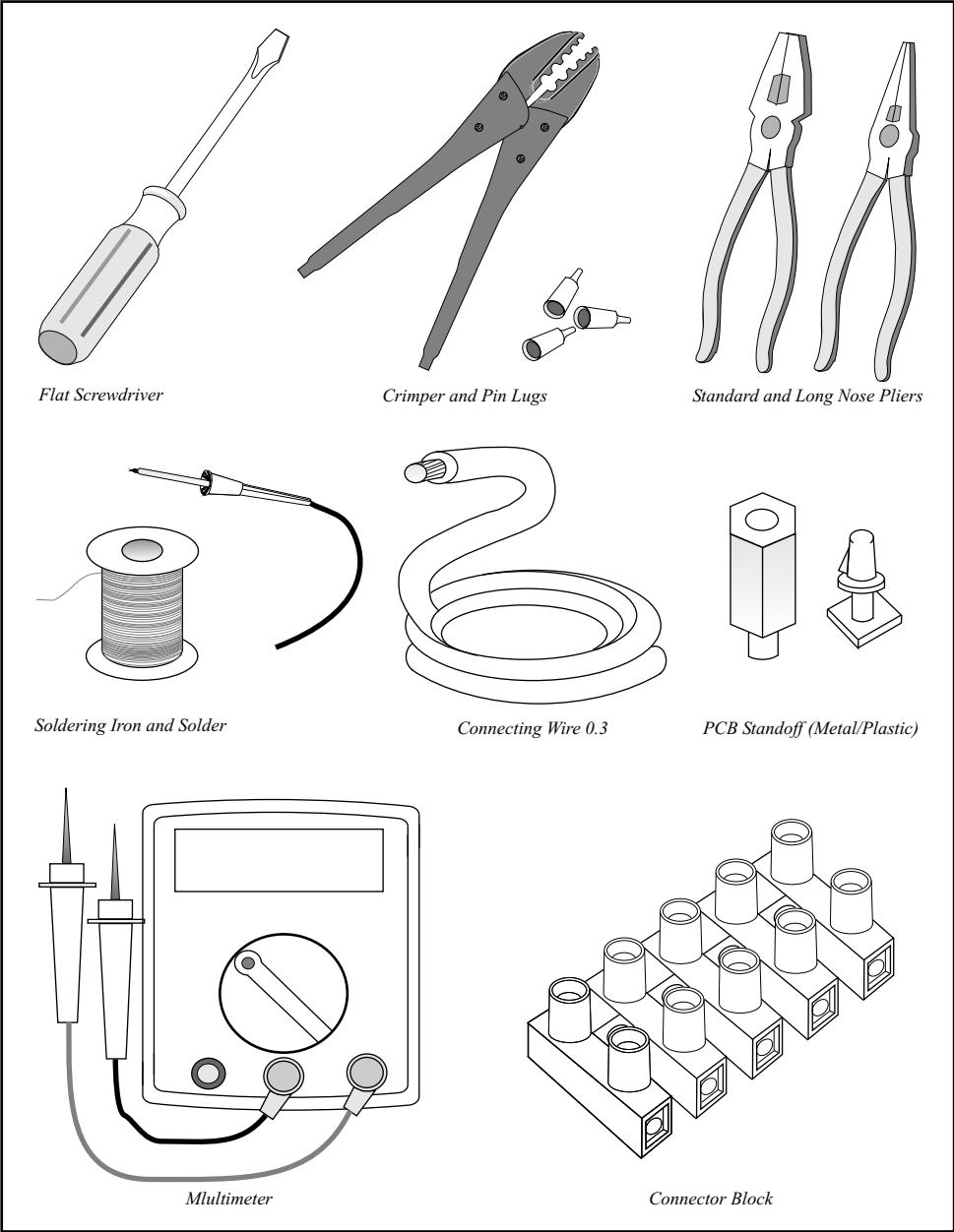

*Flat Screwdriver*

*Crimper and Pin Lugs*

*Standard and Long Nose Pliers*

*Soldering Iron and Solder*

*Connecting Wire 0.3*

*PCB Standoff (Metal/Plastic)*

*Multimeter*

*Connector Block*

*Figure 3 Required Tools and Equipment*

# Site Considerations

---

## Considerations for new installations:

1. A suitable enclosure must be chosen for installation, especially where the product is mounted outside. This enclosure must be IP56 rated to prevent moisture problems and shock hazards. The use of proper cable glands is mandatory.
2. If an existing mains supply is available, ensure that it is fed from a separate circuit breaker on the distribution board of the premises. Don't forget to install a double pole isolator switch if one does not exist. If there is no mains supply, you will have to install a cable from the distribution board to the installation point. Please be very sure to comply with the relevant installation rules in this regard. If in doubt consult an electrician.
3. The product must be installed such that it is very difficult or impossible to tamper with it from the outside of the premises.
4. The installed product i.e. the card and it's enclosure should be installed in a manner that it does not obstruct the movement of the gates especially when for example, a swing gate approaches a wall in the fully open position.
5. Ensure that the product is suitable for the intended application.
6. Key switches for the special features i.e. Pedestrian, should be mounted inside as opposed to outside the premises.
7. The mass and length of the gate you intend operating should be within the combined specifications of this product and the operator you choose to install.
8. The operators you intend using with this product should be within the specification of this controller. Using operators that exceed the specified ratings of this product may cause damage to this product and be a potential fire hazard.

## Considerations for replacement/upgrade of existing sites using other products:

1. The existing enclosure must be adequate. Check that there is enough space to mount this card without causing problems.
2. Ensure that the existing enclosure seals properly. Check the seals and replace if necessary.
3. Has a double-pole isolator been fitted? If not, install one. This is a very necessary safety item.
4. The existing operators must be within the card's specifications. If this is not the case the use of additional control equipment may be necessary for example, the use of contactors to control existing three phase motors.
5. In most cases, the original mounting bosses in the enclosure will line up with the holes provided on this card. If this is not the case, install adhesive plastic standoffs or fit additional mounting bosses/standoffs to securely mount the card.
6. Make sure that any existing equipment i.e. the radio, beams, solenoid lock, etc are compatible with this product. Many systems by other vendors operate all ancillary equipment (i.e. radio, beams, loop detectors, etc...) from a 24 volt supply. This product provides a 12 volt supply. You may have to reconfigure or replace some of the existing ancillary equipment to operate at 12 volts. Also, be aware that the 12 volt supply is NOT sufficient to drive solenoid locks. In such a case you will have to fit an additional transformer to operate the solenoid lock exclusively.
7. Always document the existing connections before removing the existing board. This will save you a lot of time should you need to put everything back the way it was for some reason.

# **Site Considerations**

---

8. You may have to extend the internal wiring inside the box. This is often the case when replacing the existing board with a different product. Use terminal block ("chockblock") and lengths of wire to do this. Ensure that the wire you use is sufficient to carry the rated currents.
9. Ensure that there is an EARTH connection inside the box and ensure that the card is connected to this EARTH. Lightning protection is rendered ineffective if this rule is not observed.
10. Check the courtesy light, if present. Be careful that the wattage of this lamp does not exceed the switching current rating of the relay on this card.
11. Check the condition and suitability of the wiring at the existing site. The use of two-core norse cable, where the earth conductor is used as a neutral, leaving the motors un-earthed is not acceptable for use with this product. Replace the cable with a 4-core type if this is the case.

# New Installation Items and Cabling Requirements

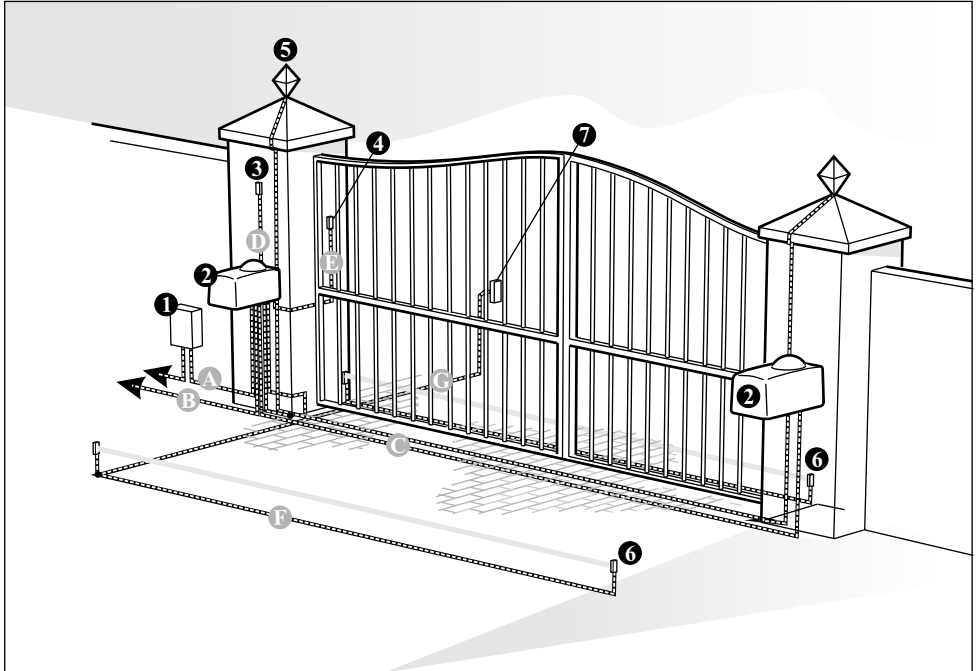

## LIST OF ITEMS AND THEIR DETAILS

### System Components

- |    |   |    |                       |
|----|---|----|-----------------------|
| 1. | CP 93 Control unit in IP56 Enclosure                                    | 5. | Courtesy Lamp         |
| 2. | Operator (Linear type shown here, may differ as per installer's choice) | 6. | Infra-red safety beam |
| 3. | Radio Receiver  | 7. | Intercom Gooseneck    |
| 4. | Radio receiver cable (3 core 0,5mm <sup>2</sup> Multistranded).         |    |                       |

### Cabling Details

- |    |   |    |   |
|----|---|----|---|
| A. | Mains cable, three (3) core; LIVE, NEUTRAL, EARTH. Core area 8.5mm <sup>2</sup> min. (increase this according to lamp wattage and operator size).             | D. | Radio receiver cable; 3 core 0.5mm <sup>2</sup> multistranded |
| B. | Intercom cable n1+6 core to house   | E. | Pedestrian Keyswitch; 2 core 0.5mm <sup>2</sup> multistranded |
| C. | Slave motor cable, 3- core + earth conductor with core area of 3.5mm <sup>2</sup> min. (DO NOT USE NORSE CABLE FOR THIS APPLICATION- MOTORS MUST BE GROUNDED) | F. | Infra-red beams; 3 core 0.5mm <sup>2</sup> multistranded      |
|    |   | G. | Intercom cable; n2+2 core multistranded 0.5mm <sup>2</sup>    |

Figure 4 New Installation Items and Cabling Requirements

# CP93 Controller Installation

## RECOMMENDED ENCLOSURE AND LAYOUT FOR NEW INSTALLATIONS

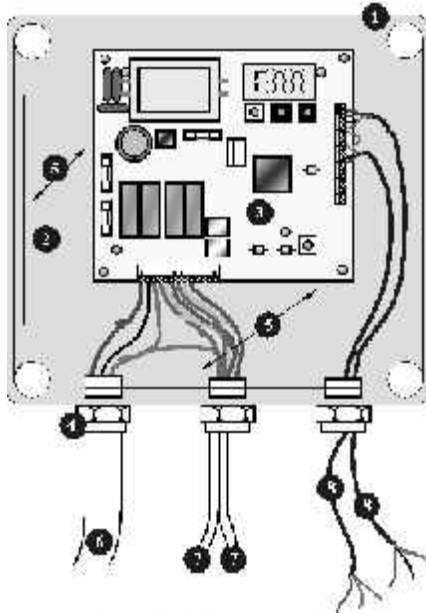

### IP56 ENCLOSURE LEGEND

1. Enclosure bottom half
2. Baseplate (plastic/metal)
3. CP93 Controller
4. Compression cable gland
5. Compression cable gland mains isolator, solenoid lock transformer, etc.
6. Mains supply cable from dwelling
7. Cables to gate operator motors
8. Signal cable(s): (beams, radio receiver, pedestrian keyswitch, etc.)

### RECOMMENDED ACCESSORY PARTS

1. Enclosure- Centurion Type, GEWISS GW 44 207, SAREL
2. Compression Glands
3. Baseplate- 1.2mm galvanised sheet metal cut and bent to suit enclosure.



- The colour codes shown here are only for illustration. Actual colour codes may vary according to the actual motor wires, etc. However the mains supply cable colour code must comply with local regulations.
- Mount the box on a flat surface such as a wall. Use suitable fastening devices i.e. screws and rawl plugs. In cases where the enclosure is to be embedded into the wall, make sure that the top cover mates properly with the base and that the compression glands are properly fastened.
- The isolator switch (not shown) may be mounted inside the enclosure if space permits.
- Mount the card to the baseplate (if fitted) using recommended plastic stand-offs. The use of metal stand-offs are permitted provided a metal baseplate is present and is earthed. Metal standoff's overall diameter may not exceed 6mm.
- This product **MUST** be earthed even if it is installed in a completely plastic enclosure.

Figure 5 CP93 Recommended Enclosure

# CP93 Electrical Set-up

**⚠ DANGER**  
**HAZARDOUS VOLTAGES.**  
**REMOVE POWER WHEN**  
**MAKING CONNECTIONS**

The following pages describe details of the electrical connections that need to be made to the CP93 in order that it shall function as expected. Please read the following section thoroughly. Kindly also take note of any special instructions with regard to mains wiring.

## CP93 Connections Terminal Functions & Descriptions

### Power Terminals

#### 1. AC Mains

L = LIVE Live conductor of AC mains supply  
N = NEUTRAL Neutral conductor of AC mains supply

E = EARTH Earth conductor of AC mains supply and building

#### 2. Master Motor

R = REVERSE Reverse winding of motor  
COM = COMMON Motor winding common (neutral)

F = FORWARD Forward winding of motor

#### 3. Slave Motor

R = REVERSE Reverse winding of motor

COM = COMMON Motor winding common (neutral)

F = FORWARD Forward winding of motor

#### 4. Light

Potential-free relay contact for controlling a courtesy lamp. Normally open contact.

#### 5. Solenoid

Selectable N.O. or N.C. potential free relay contact. Contact type can be selected as needed by changing the jumper on the card as shown: Max. Current capacity of SOLENOID relay contact is 1 AMP @ 24VDC

### Signal Terminals and Names

**TRG** -Trigger input signal from radio receiver.

**PED** -Pedestrian mode activation signal.

**BM1** -Opening beam input / motor error signal\*

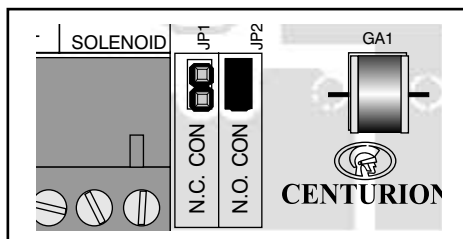

Figure 6 Normally Open (N.O.)

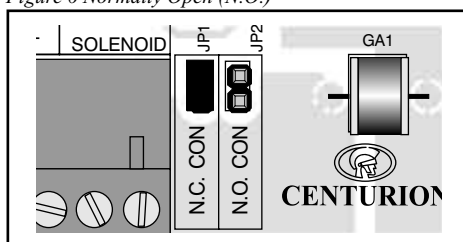

Figure 7 Normally Closed (N.C.)

**BM2** -Standard safety beam input (closing beam)

**FRX** -Free Exit signal input from FREE EXIT Pushbutton

**STP** -Emergency Stop input

**LED** -Status LED output

**LIT** -Light Control button input signal

**MLO** -Master Gate Open Limit Switch

**MLC** -Master Gate Closed Limit Switch

**SLO** -Slave Gate Open Limit Switch

**SLC** -Slave Gate Closed Limit Switch

**12V** -Auxillary 12 VDC supply output terminal

**COM** -Common terminal, internally connected to Negative.

*\*See Programming section for detailed explanation of the mode of operation of this pin. Check max lamp wattage before using to determine if this relay contact is sufficiently rated to handle the lamp.*

# Terminal Identification and numbering of the CP93

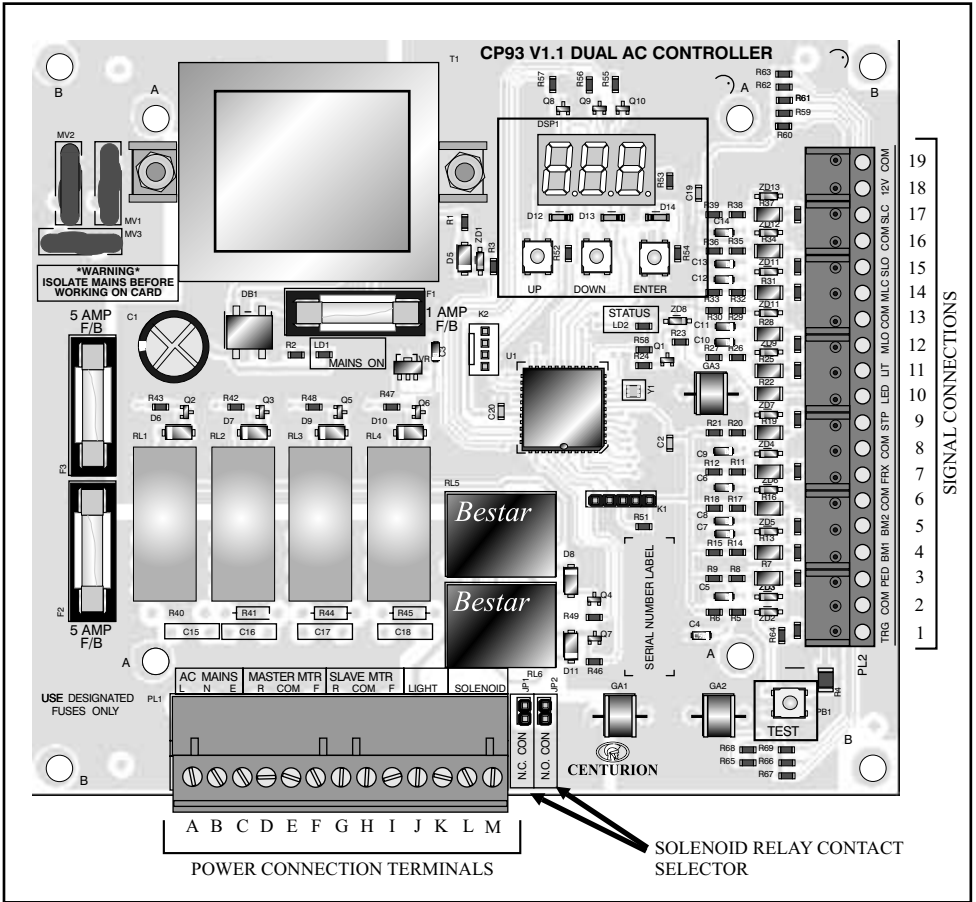

Figure 8 Terminal Identification

## Solenoid Relay Contacts

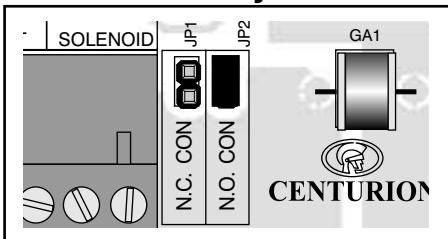

Figure 9 Normally Open Contact

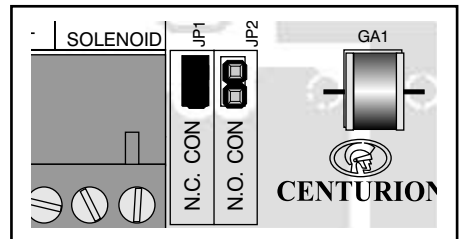

Figure 10 Normally Closed Contact



# Power Connection Terminals

A = Live  
 B = Neutral  
 C = Earth

## AC Mains Input

D = Master Motor REVERSE direction winding  
 E = Master Motor COMMON (neutral)  
 F = Master Motor FORWARD direction winding  
 G = Slave Motor REVERSE direction winding  
 H = Slave Motor COMMON (neutral)  
 I = Slave Motor FORWARD direction winding  
 J = Lamp Relay Contact  
 K = Lamp Relay Contact

L = Solenoid Relay Contact  
 M = Solenoid Relay Contact

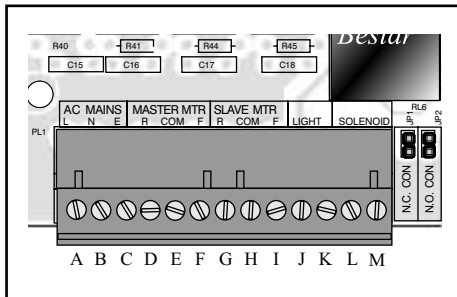

Figure 11 Power Connection Terminals

# Signal Connections

- |                                   |                                    |
|-----------------------------------|------------------------------------|
| 1 TRIGGER INPUT                   | 11 LIGHT CONTROL BUTTON            |
| 2 COMMON                          | 12 MASTER MOTOR OPEN LIMIT SWITCH  |
| 3 PEDESTRIAN                      | 13 COMMON                          |
| 4 BEAM 1 / MOTOR COLLISION SENSE† | 14 MASTER MOTOR CLOSE LIMIT SWITCH |
| 5 BEAM 2 [STANDARD SAFETY BEAM]   | 15 SLAVE MOTOR OPEN LIMIT SWITCH   |
| 6 COMMON                          | 16 COMMON                          |
| 7 FREE EXIT                       | 17 SLAVE MOTOR CLOSE LIMIT SWITCH  |
| 8 COMMON                          | 18 12V DC SUPPLY‡                  |
| 9 STOP [E.M.G. STOP BUTTON]       | 19 COMMON (0V/GND)                 |
| 10 STATUS LED                     |                                    |

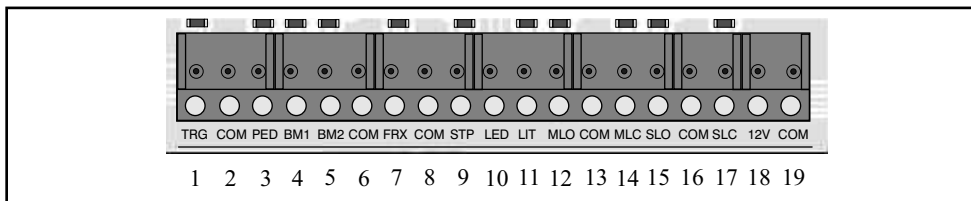

Figure 12 Signal Connections



† Configuration depends on programmed options - refer to programming section later in this manual.

‡ This supply is limited and is only sufficient to supply power to a radio and two beams. DO NOT USE FOR SOLENOID LOCK or ANY OTHER USE.

## MOTOR AND LIMIT SWITCH CONNECTIONS - DOUBLE NORMALLY OPEN/NORMALLY CLOSED LIMIT SWITCHES

Master Motor

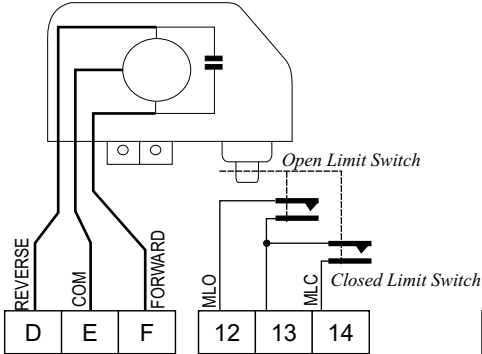

Slave Motor

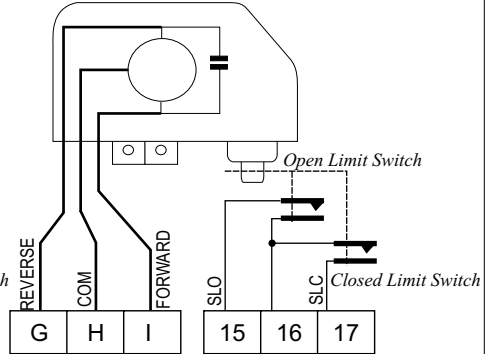

•CP93 must be programmed according to the type of limit switch you use. If you install NORMALLY OPEN type switches you must program the card accordingly.

## MOTOR AND LIMIT SWITCH CONNECTIONS - SINGLE NORMALLY OPEN/NORMALLY CLOSED LIMIT SWITCHES

Master Motor

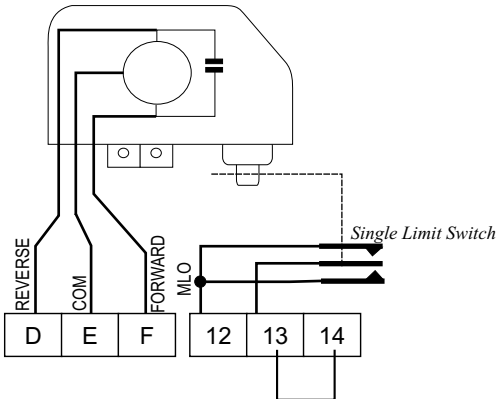

Slave Motor

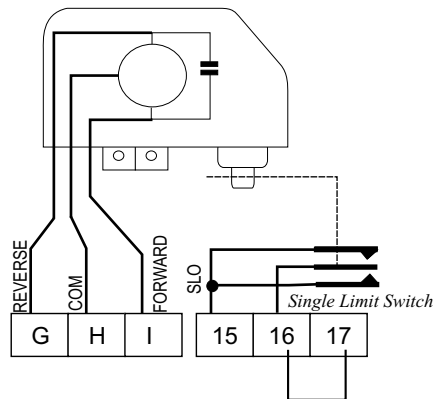

•CP93 must be programmed according to the type of limit switch you use. If you install NORMALLY OPEN type switches you must program the card accordingly. The wire links must be fitted as shown for this configuration as well as the appropriate limit switch mode programmed into the card.

Figure 13 Motor and Limit Switch Connections -Double Normally/Single Normally

## RADIO CONNECTIONS

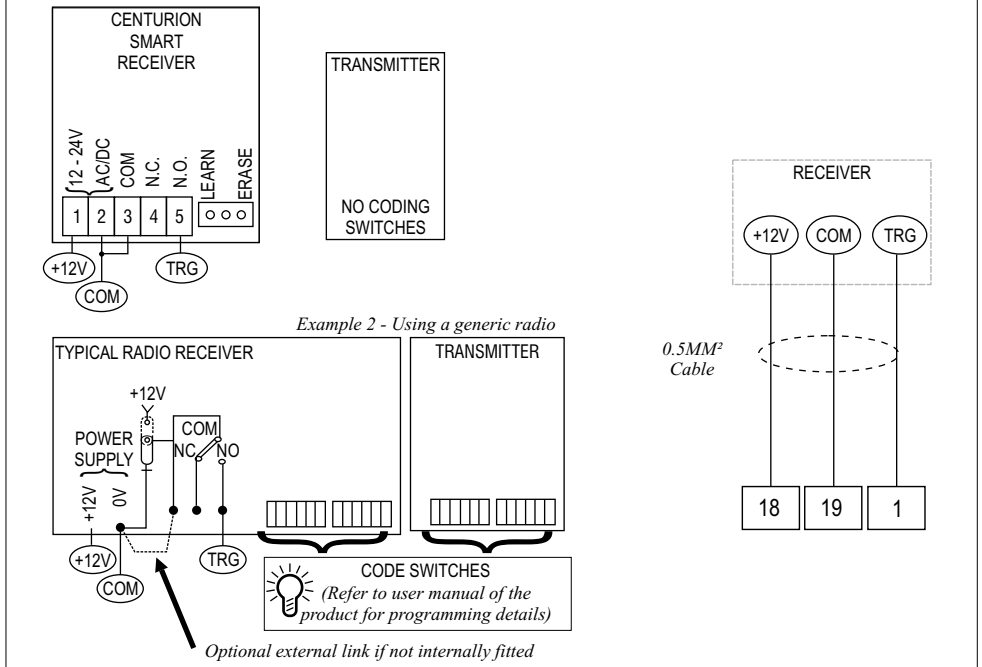

Figure 14 Radio Connections

## INTERCOM CONNECTIONS

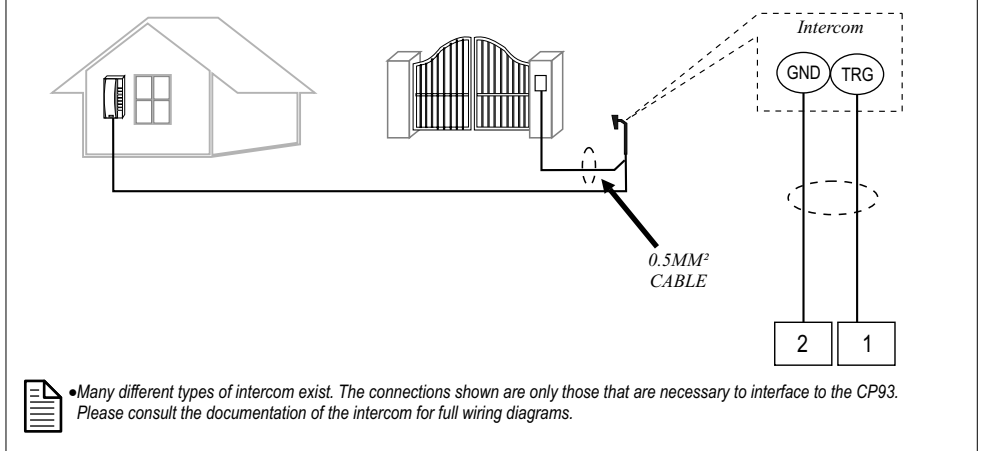

Figure 15 Intercom Connections

# SOLENOID / MAGNETIC LOCK

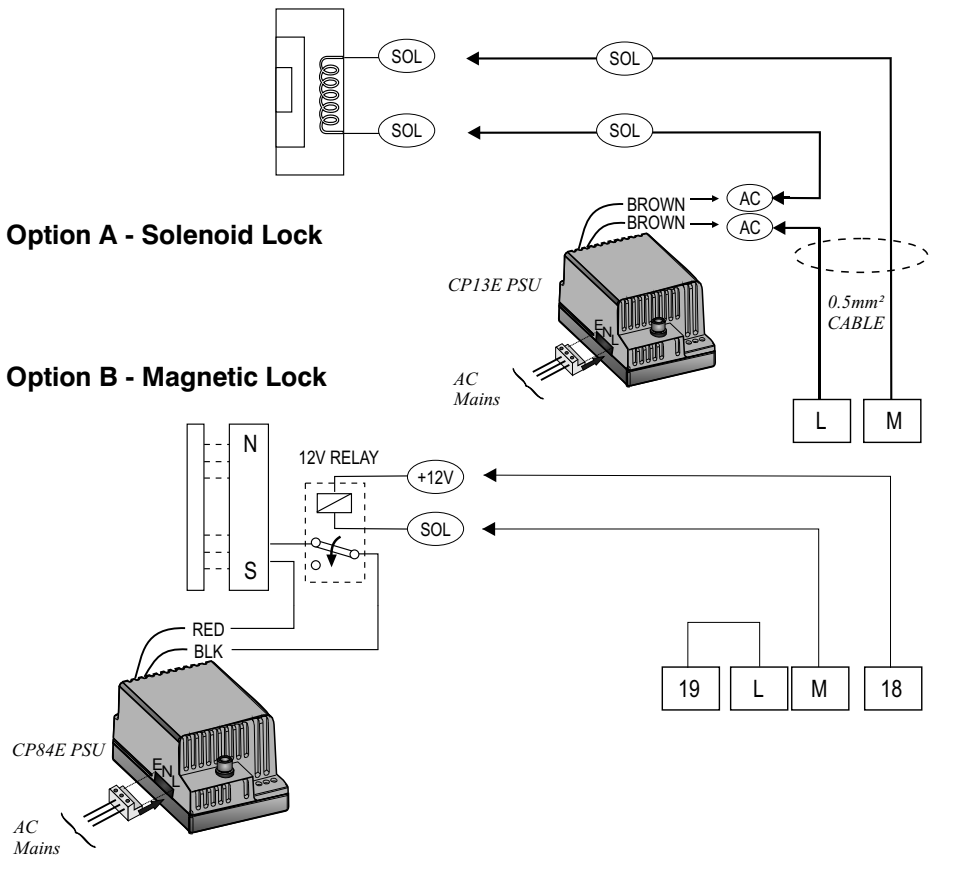
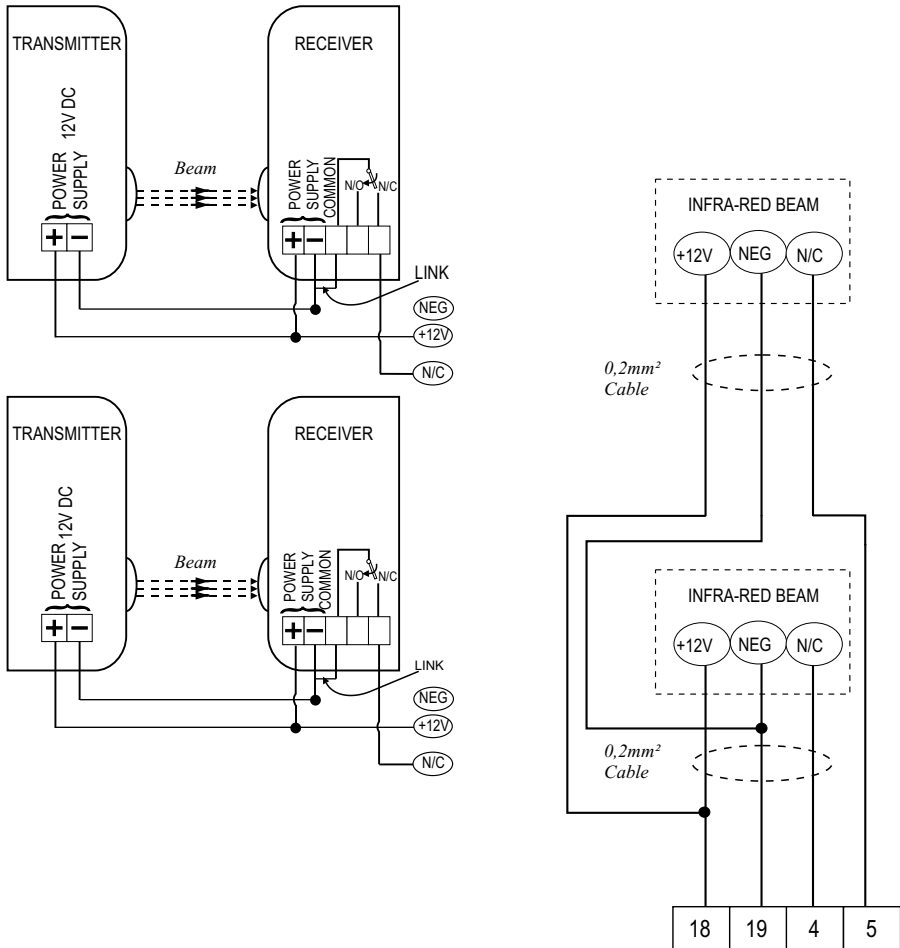

Figure 16 Solenoid/Magnetic Lock



## INFRA-RED BEAMS



- Opening safety beam is optional. if the opening safety beam is not fitted, place a wire bridge between BM1 (pin 4) and common (pin6).
- Input pin BM1 (pin 4) cannot be used for a beam and as a motor stall/collision sense input at the same time. ensure that the mode of operation of this pin is correctly programmed for the intended configuration.
- Make sure you use the normally closed contacts of the beam relay and not the normally open contacts as is the case with other products.

Figure 19 Infra-Red Beams

## PEDESTRIAN KEYSWITCH

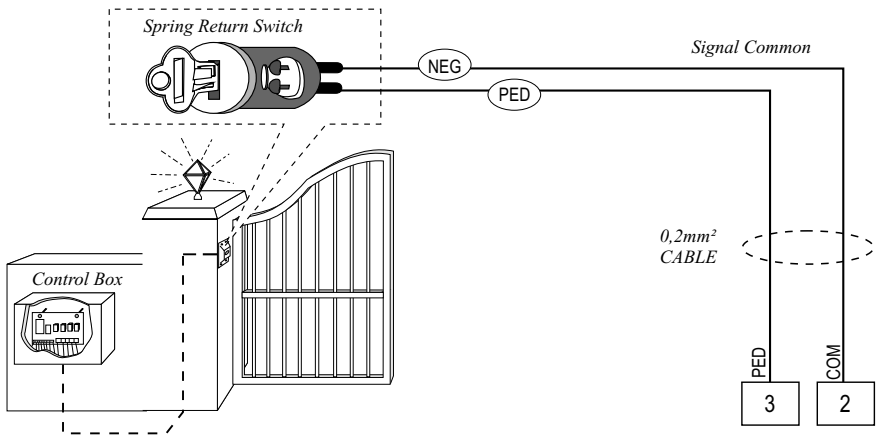

Figure 20 Pedestrian Keyswitch

## FREE EXIT LOOP

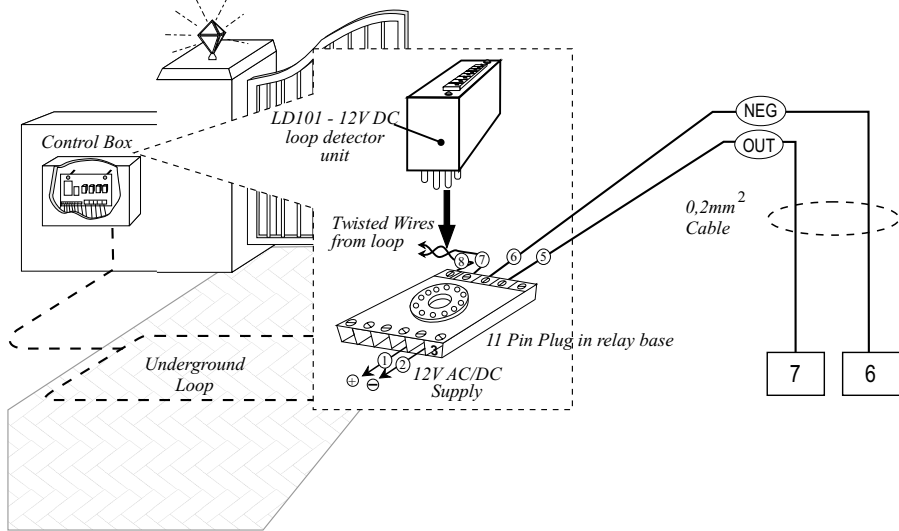

Figure 21 Free Exit Loop

## STATUS LED

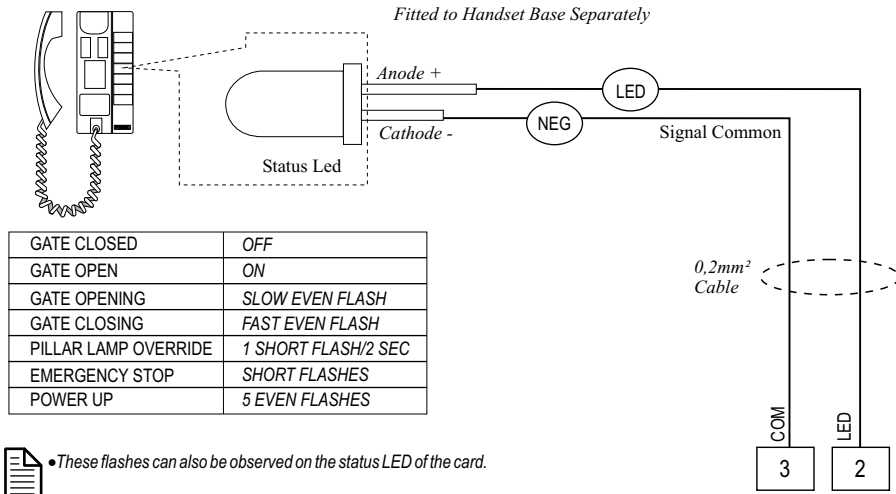

Figure 22 Status LED

## PILLAR/COURTESY LAMP(S)

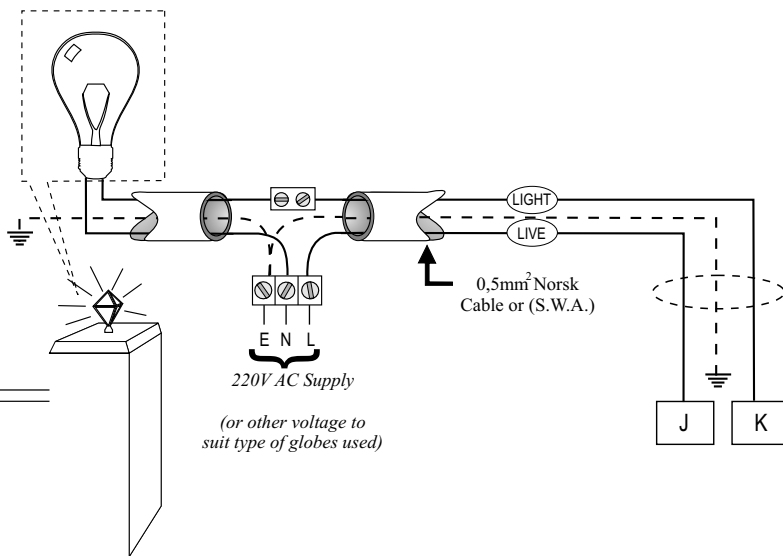

Figure 23 Pillar / Courtesy Lamp(s)



## PILLAR LIGHT CONTROL

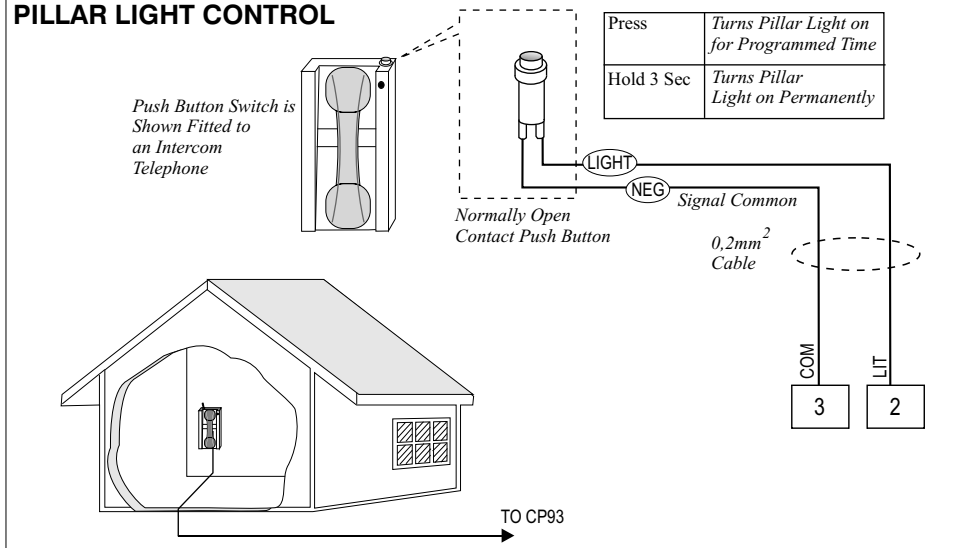

Figure 24 Pillar Light Control

## EMERGENCY STOP BUTTON (OPTIONAL)

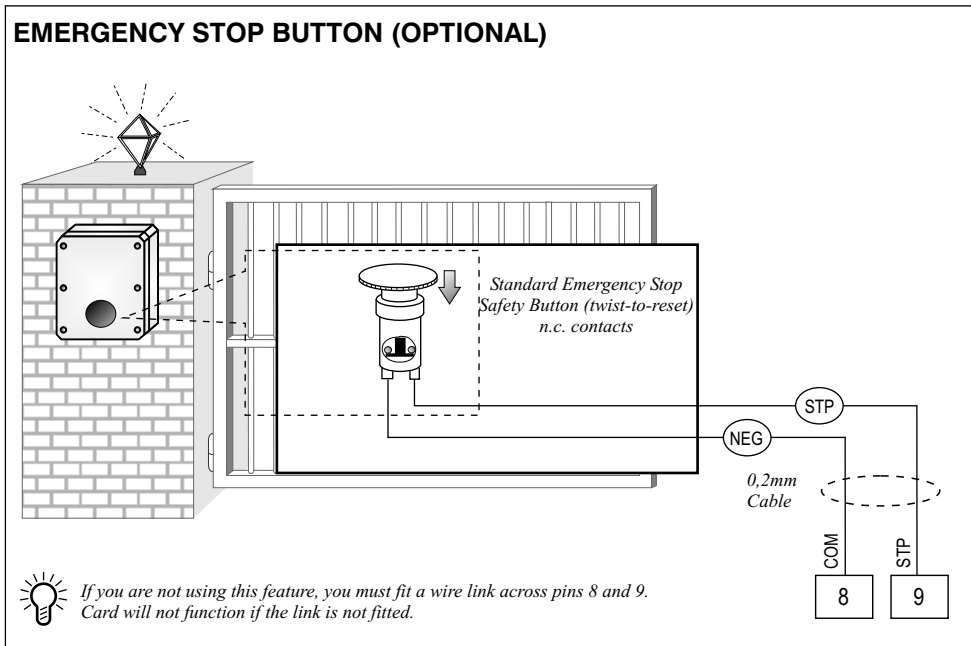
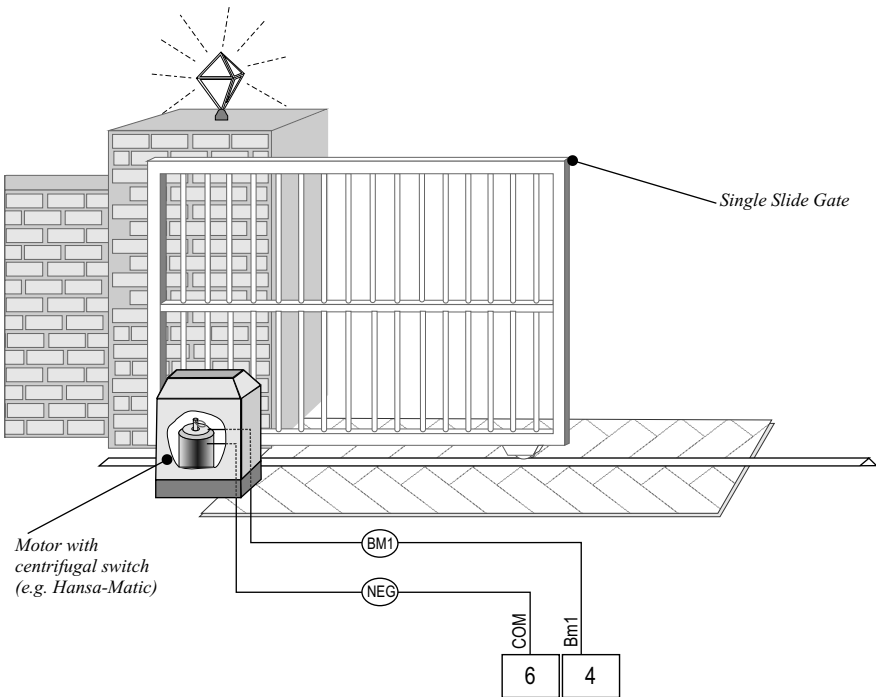

Figure 25 Emergency Stop Button (optional)

## BEAM 1 INPUT USED FOR MOTORS WITH CENTRIFUGAL CONTACT



Card must be programmed for this configuration to work.



- In this mode, the centrifugal switch has the same action as a beam, if the motor stalls as a result of, for example, pushing against an obstruction in its path, the CP93 will sense this on the beam 1 input. the action will be a stop-reverse sequence.
- To implement the other modes such as CONDO and PIRAC, it is still necessary to install a safety beam
- The time it takes for the centrifugal switch to come in after the motor has started is fixed to roughly one second. in situations where the CP93 is to replace an existing board, be sure that the motor does spin up within 1 second. in other words the centrifugal switch must have been activated within a second after the motor is started.

Figure 26 Beam 1 Input Used for Motor with Centrifugal Contact

# CP93 Programming

## Orientation in the CP93 Programming Interface

The CP93 has a built-in programming interface consisting of an LED display and three push buttons.

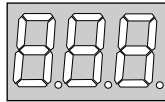
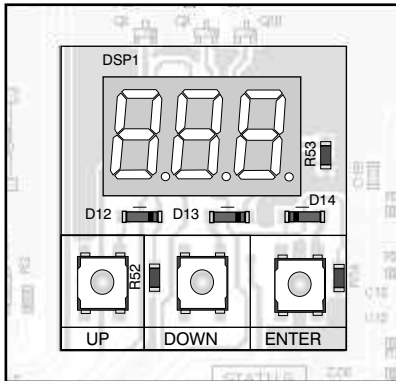

**The Display** shows the information about the card's settings and allows the user to see what options are available to change the settings.

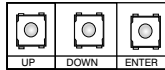

**The Push Buttons** allow the user to edit values, change settings and to gain access to all the programmable features of the product.

Figure 27 Programming Interface

## Basic Programming Menu Navigation

The CP93 has a built-in programming interface consisting of an LED display and three push buttons.

### **! IMPORTANT**

Normal card operation is suspended when programming mode is selected. Gates cannot be opened or closed whilst in programming mode.

Programming mode can only be invoked if the gate has completed its current cycle.

### 1. Invoking the Programming Menu

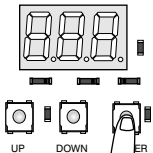

1.1. Press and hold the "ENTER" pushbutton for 2 seconds.

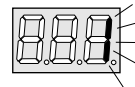

1.2. Display turns on. Release the "ENTER" pushbutton.

## 2. Selecting an Item for Editing

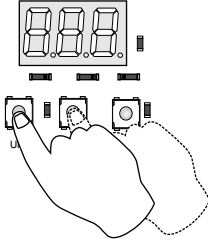

When the Programming menu is invoked, the display shows "1". This is the first item in the main menu.

2.1. Press the "UP" or "DOWN" push buttons to increment or decrement to the desired menu item number. Hold the button for at least 1 second to scroll rapidly.

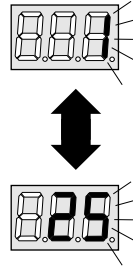

2.2. The main menu contains up to 25 items. Scrolling upwards past 25 causes a wrap to number 1, while scrolling downwards past 1 wraps to 25.

## 3. Accessing the Selected Item

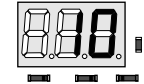

3.1. Press the "ENTER" pushbutton while the desired menu item number is displayed



3.2. The abbreviated name of the item being edited is displayed for 1 second.



3.2. The currently programmed value is displayed!

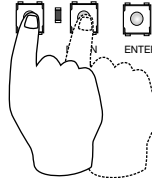
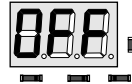

3.3. Press the "UP" or "DOWN" push buttons to change the settings

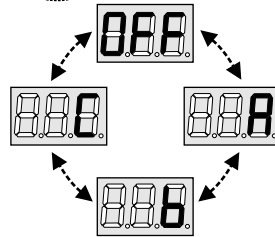

3.4. Pressing UP or DOWN cycles through the various available options for the currently selected menu item in a circular fashion.



BUT, for menu items that contain numerical data, the "UP" and "DOWN" keys increment, or decrement the displayed value

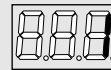

## 4. Saving your Changes to the Selected Item

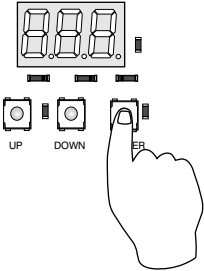

4.1. To save your change (or to return to the main menu if nothing has been changed) simply press the "ENTER" push button.



4.2. The changes are saved to non-volatile storage with confirmation ("Set" is briefly displayed) and the display returns to the last selected position in the main menu.



### Aborting the Programming Menu to Discard Changes

If, you have changed something and you are unsure about it and want to exit the menu system and discard your changes, there is an easy way to do this: To exit the Programming menu and return to normal operation, simply refrain from pressing any of the buttons for 20 seconds. After 30 seconds have elapsed the menu will expire and the card will return to operational mode. All changes made however, will be lost and the previous set of settings will apply. This only applied if you have an edited setting on the display and have NOT yet pressed "ENTER".

## 5. Exiting the Programming Menu after Changes have been made

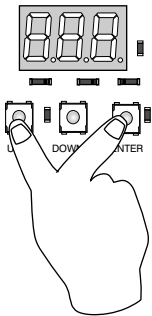

5.1. To save all changes and exit the programming menu, i.e. to go back into normal operational mode, press the "UP" and "ENTER" push buttons simultaneously.



5.2. The display turns off and normal card operation resumes.

OR

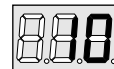



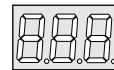



wait 30 seconds







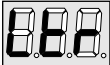













5.3. Leave the card, i.e. don't press any keys for at least 30 seconds and the card will exit the programming menu automatically!

## Programmable Options of the CP93

This is a table of all the programmable features of the CP93. For the convenience of the experienced installer, this table includes the number of the page where the specific details of the feature may be found.

No.	Abbrev. Name	Feature	Description	Options	Pg
1		Limit Switch Configuration	Programmable Options for Limit Switch Types	Double N.C. Contact Double N.O. Contact Single N.C. Contact Single N.O. Contact Free Running	33
2		Auto-Close Function	Turn Auto-close function ON/OFF (Note: This setting is forced to ON and is not editable in CONDO/PIRAC mode)	OFF ON	34
3		Auto-Close Time	Time delay that must expire before Auto-Close function activates	1 second to 255 seconds	35
4		OPERATING MODE	Selection of the OPERATING MODE of the product	STANDARD MODE CONDO MODE PIRAC MODE REVERSING MODE PLC MODE DEADMAN MODE	36
5		Pedestrian AUTO CLOSE Time	Time delay that must expire before a pedestrian gate is automatically closed	1 second to 255 seconds	37
6		Pillar/Courtesy Light	Length of time that the Pillar/Courtesy light remains on for after the gate is closed	10 seconds to 255 seconds	38
7		Pedestrian RUN time	Length of time that the MASTER motor must run to open the gate sufficiently wide enough to allow pedestrians to enter	1 second to 255 seconds 0 = turned off	39

No.	Abbrev. Name	Feature	Description	Options	Pg
8		Auto-Close Override	Length of time that the TRIGGER button must be held to invoke AUTO-CLOSE override	1 second to 255 seconds	40
9		Safety Type on BM1 Terminal	Programs the functionality of the BM1 Terminal	Normally Closed <i>(for standard IR5 beam)</i> Normally Open Delayed <i>(Centrifugal switch)</i>	41
10		Pillar Lamp Pre-flashing Mode of Operation	Programming of the Pre-Flash/Flash Modes of the Pillar Lamp/ Courtesy Light	Pre-Flash PFF Mode A Mode B Mode C	42
11		Pre-Flashing Time	Length of time that the Pillar lamp pre-flashes (only applicable if preflashing mode has been selected)	1 second to 255 seconds	43
12		Reversal Delay Time	Motor Reversal Delay Time	0.1 second to 25.5 seconds	44
13		Leaf Delay Order Selection	Selection of which gate opens first, i.e. which gate is defined as MASTER	A - B B - A	45
14		Leaf Delay Time	Time delay between master and slave gate to allow for leaf clearance	1 second to 255 seconds	46
15		Solenoid/ Magnetic Lock Timer	Length of time that the card will energize the solenoid/magnetic lock when opening the gate	1 second to 255 seconds	47
16		Master Motor run time	Length of time that the MASTER motor must run for to open the gate fully	1 second to 255 seconds	48

No.	Abbrev. Name	Feature	Description	Options	Pg
17		Slave Motor run time	Length of time that the SLAVE motor must run for to open the gate fully	1 second to 255 seconds	49
18		Power Factor Relay 1	Adjusts the phase angle of Relay 1 [MASTER CLOSE]	-10 to +10	50
19		Power Factor Relay 2	Adjusts the phase angle of Relay 2 [MASTER OPEN]	-10 to +10	51
20		Power Factor Relay 3	Adjusts the phase angle of Relay 3 [SLAVE CLOSE]	-10 to +10	52
21		Power Factor Relay 4	Adjusts the phase angle of Relay 4 [SLAVE OPEN]	-10 to +10	53
22		Mains Frequency	Selection of the line frequency	50Hz 60Hz	54
23		Pedestrian Mode Error Compensation	Lengthens the closing cycle in Pedestrian Mode to compensate for positioning error	1 - 255 seconds (0 = disabled)	55
24		Post-Solenoid Delay	Delays motor activation for the preset time after the solenoid becomes active	1 - 255 seconds (0 = disabled)	56
25		Solenoid Lock Pressure Release Mode	Enables/Disables the solenoid lock strain relief routine that is executed each time the gate is opened	ON/OFF	57



# Programming each Menu Item

## 1. LIMIT SWITCH CONFIGURATION

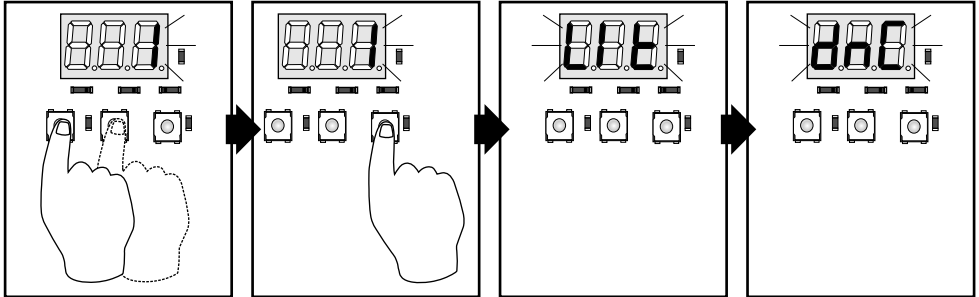

1.1. Scroll until the "1" is displayed, i.e. this menu item

1.2. Press "ENTER" to select it for editing

1.3. Menu name is displayed in abbreviated form

1.4. Current setting for this menu is displayed

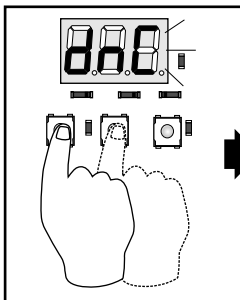

1.5. Use "UP" and "DOWN" buttons to select desired configuration from the available

	<b>DOUBLE NORMALLY CLOSED CONTACTS</b> Applicable to both sets of OPEN and CLOSED limit switches
	<b>DOUBLE NORMALLY OPEN CONTACTS</b> Applicable to both sets of OPEN and CLOSED limit switches
	<b>SINGLE NORMALLY CLOSED CONTACTS</b> Applicable to the single limit switch on each motor
	<b>SINGLE NORMALLY OPEN CONTACTS</b> Applicable to the single limit switch on each motor
	<b>FREE RUN</b> No limit switches - uses run times to determine limits

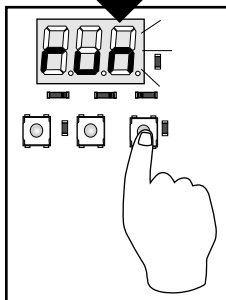

1.6. Press "ENTER" to save the changes

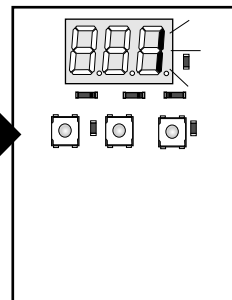

1.7. Returns to the main menu at the same point you were last time



See page 18 for corresponding electrical configurations!  
Also see notes referring to **LIMIT SWITCH CONFIGURATION** on pg 55

## 2. AUTO-CLOSE FUNCTION

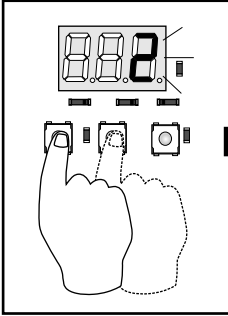

2.1. Scroll until the "2" is displayed, i.e. this menu item

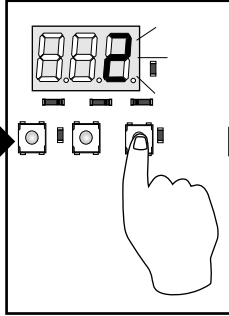

2.2. Press "ENTER" to select it for editing

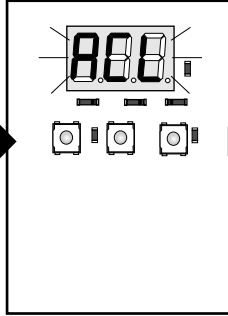

2.3. Menu name is displayed in abbreviated form

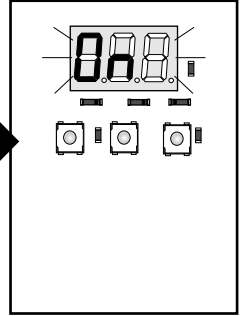

2.4. Current setting for this menu is displayed

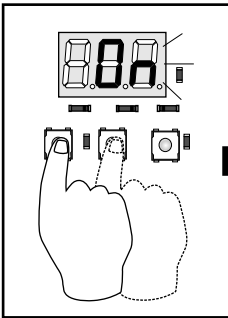

2.5. Use "UP" and "DOWN" buttons to select desired configuration from the available options.

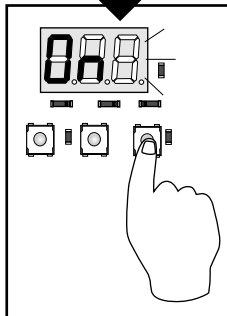
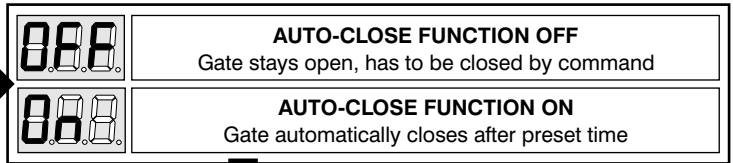

2.6. Press "ENTER" to save the changes

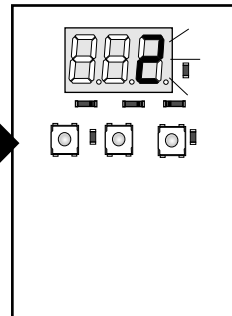

2.7. Returns to the main menu at the same point you were last time



See notes referring to AUTO-CLOSE FUNCTION on pg 55

### 3. AUTO-CLOSE TIME

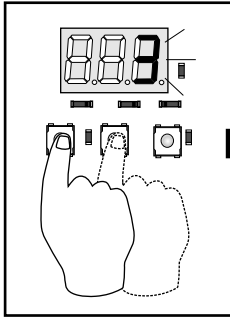

3.1. Scroll until the "3" is displayed, i.e. this menu item

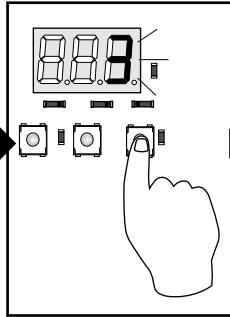

3.2. Press "ENTER" to select it for editing

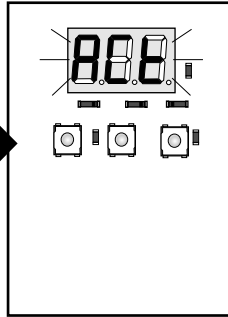

3.3. Menu name is displayed in abbreviated form

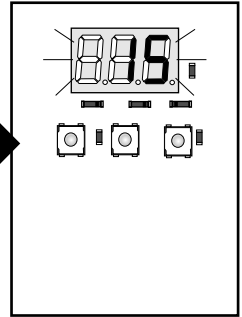

3.4. Current setting for this menu is displayed

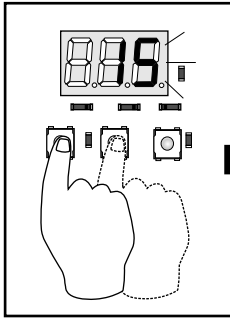

3.5. Use "UP" and "DOWN" buttons to increase or decrease the time value.

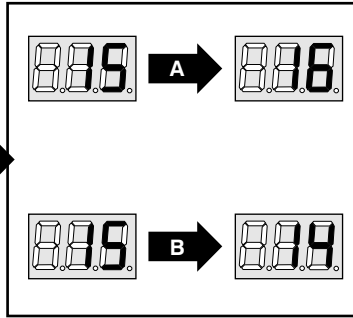

3.6. A - Pressing the "UP" key  
B - Pressing the "DOWN" key

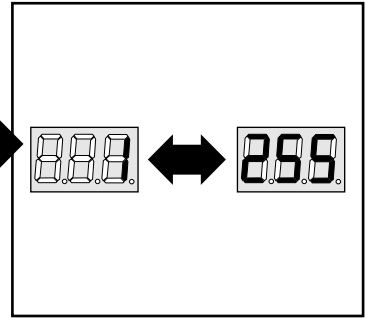

3.7. Programmable range for Auto-Close time is 1 second to 255 seconds

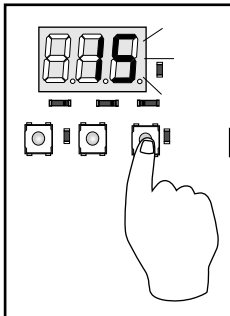

3.8. Press "ENTER" to save the changes

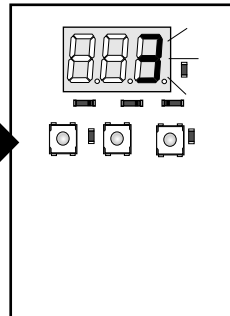

3.9. Returns to the main menu at the same point you were last time



#### Handy Tip:

#### QUICK ENTRY

- Press and hold "UP" or "DOWN" for 2 seconds to invoke fast scrolling.
- Holding the key for a further 5 seconds invokes scrolling in units x10
- Release key to stop

## 4. OPERATING MODE

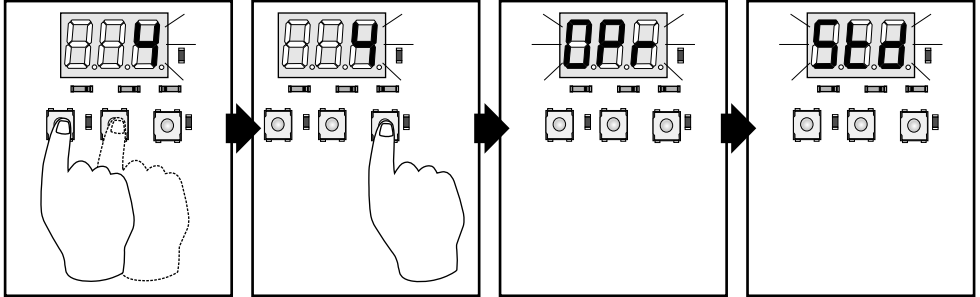

4.1. Scroll until the "4" is displayed, i.e. this menu item

4.2. Press "ENTER" to select it for editing

4.3. Menu name is displayed in abbreviated form

4.4. Current setting for this menu is displayed

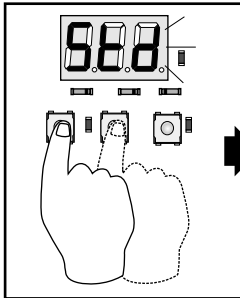

4.5. Use "UP" and "DOWN" buttons to scroll through the available options.

	<b>STANDARD MODE</b> Standard feature set with start-stop-reverse sequencing
	<b>CONDOMINIUM MODE</b> Mode designed for communal living schemes
	<b>PIRAC MODE</b> Auto-Close when broken safety beam is restored
	<b>REVERSING MODE</b> Variation of STANDARD mode with no stop stage in multiple triggers
	<b>PLC MODE</b> Special mode allowing for control with pulse signalling from a PLC
	<b>DEAD MAN MODE</b> Special mode allowing for control with fail-safe in event of signal loss

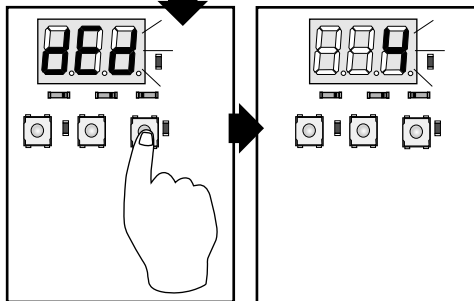

4.6. Press "ENTER" to save the changes

4.7. Returns to the main menu at the same point you were last time



See notes referring to OPERATING MODE on pg 55

## 5. PEDESTRIAN AUTO-CLOSE TIME

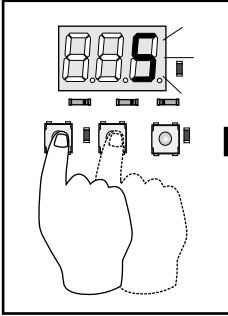

5.1. Scroll until the "5" is displayed, i.e. this menu item

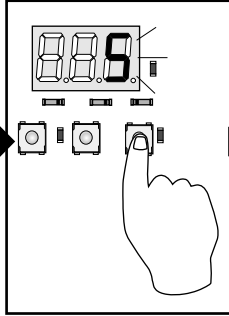

5.2. Press "ENTER" to select it for editing

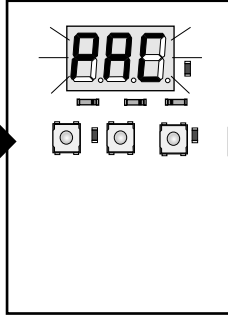

5.3. Menu name is displayed in abbreviated form

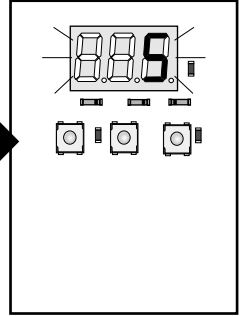

5.4. Current setting for this menu is displayed

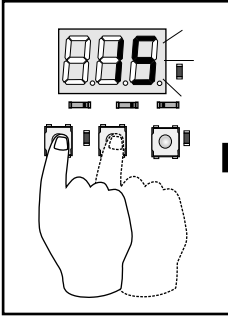

5.5. Use "UP" and "DOWN" buttons to increase or decrease the time value.

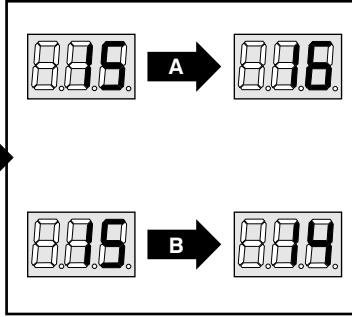

5.6. A - Pressing the "UP" key  
B - Pressing the "DOWN" key

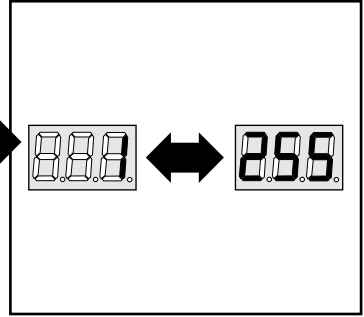

5.7. Programmable range for Pedestrian Auto-Close time is 1 second to 255 seconds

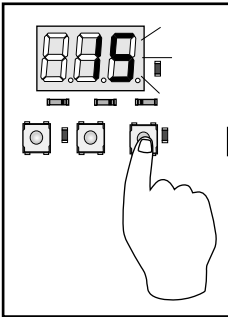

5.8. Press "ENTER" to save the changes

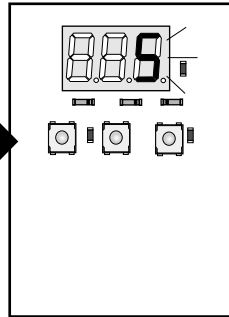

5.9. Returns to the main menu at the same point you were last time



See notes referring to PEDESTRIAN AUTO-CLOSE TIME on pg 55

## 6. PILLAR/COURTESY LIGHT TIMER

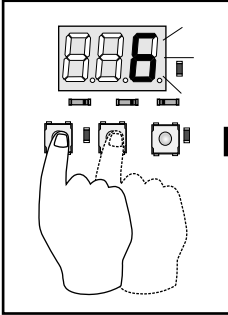

6.1. Scroll until the "6" is displayed, i.e. this menu item

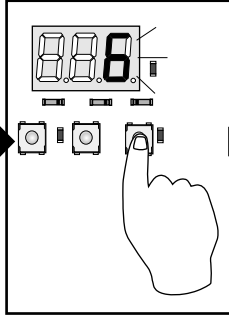

6.2. Press "ENTER" to select it for editing

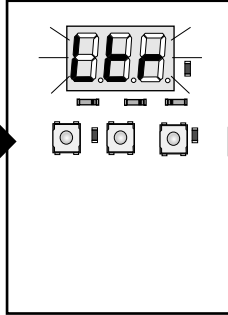

6.3. Menu name is displayed in abbreviated form

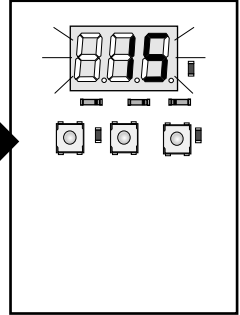

6.4. Current setting for this menu is displayed

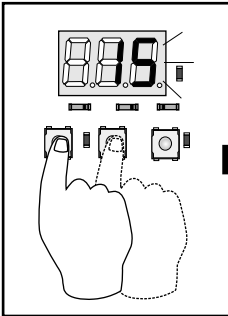

6.5. Use "UP" and "DOWN" buttons to increase or decrease the time value.

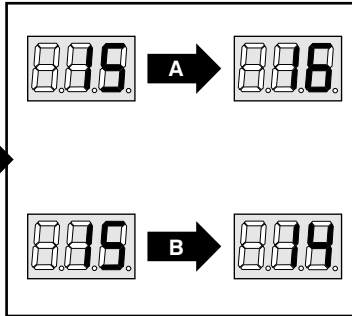

6.6. A - Pressing the "UP" key  
B - Pressing the "DOWN" key

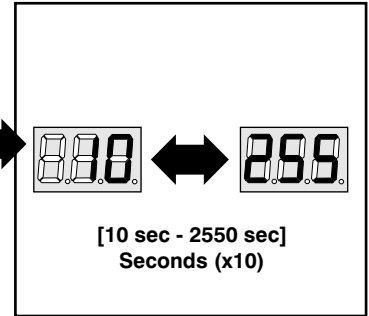

6.7. Programmable range for Light Time is 10 seconds to 255 seconds

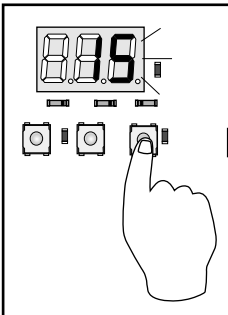

6.8. Press "ENTER" to save the changes

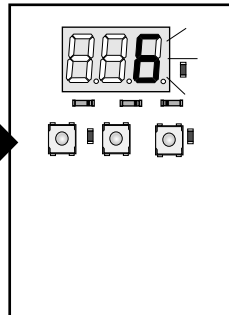

6.9. Returns to the main menu at the same point you were last time



See notes referring to PILLAR/COURTESY LIGHT TIMER on pg 55

## 7. PEDESTRIAN AUTO-CLOSE TIME

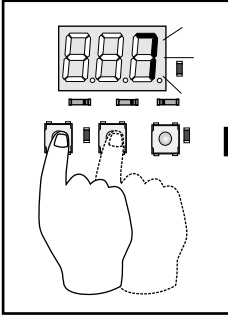

7.1. Scroll until the "7" is displayed, i.e. this menu item

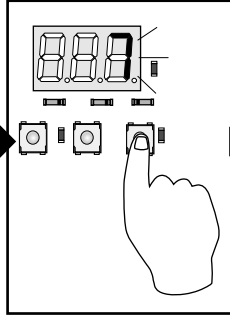

7.2. Press "ENTER" to select it for editing

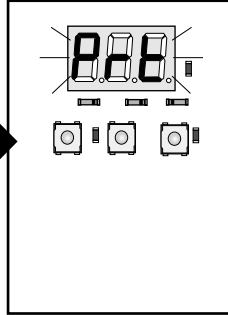

7.3. Menu name is displayed in abbreviated form

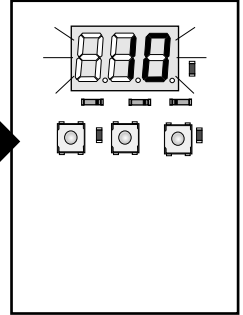

7.4. Current setting for this menu is displayed

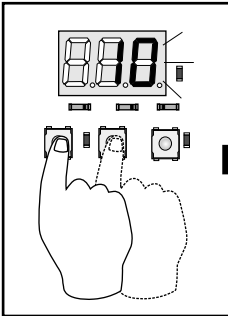

7.5. Use "UP" and "DOWN" buttons to increase or decrease the time value.

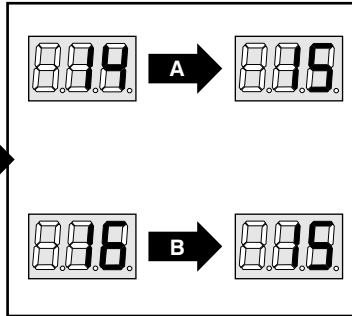

7.6. A - Pressing the "UP" key  
B - Pressing the "DOWN" key

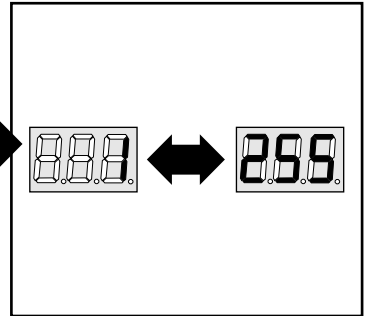

7.7. Programmable range for Pedestrian Run Time is 1 second to 255 seconds

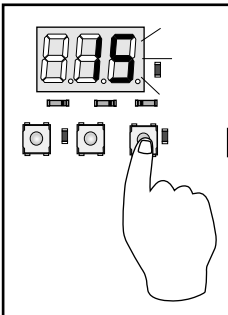

7.8. Press "ENTER" to save the changes

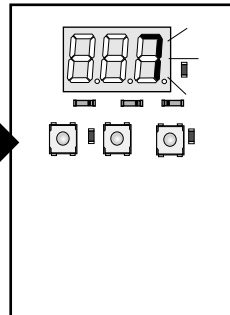

7.9. Returns to the main menu at the same point you were last time



See notes referring to PEDESTRIAN AUTO-CLOSE TIME on pg 56

## 8. AUTO-CLOSE OVERRIDE TIMER

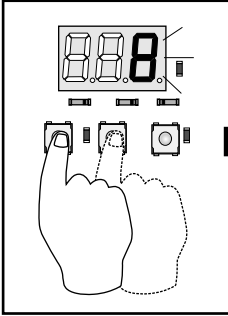

8.1. Scroll until the "8" is displayed, i.e. this menu item

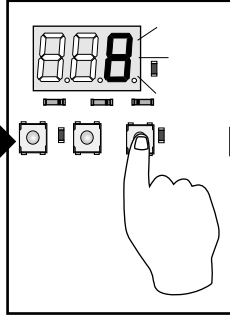

8.2. Press "ENTER" to select it for editing

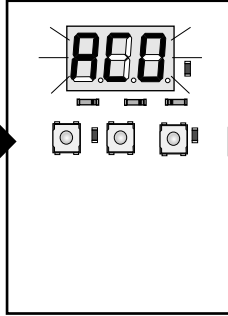

8.3. Menu name is displayed in abbreviated form

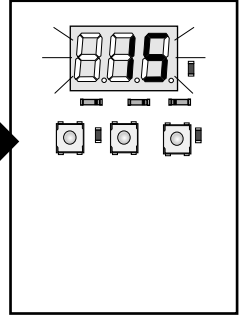

8.4. Current setting for this menu is displayed

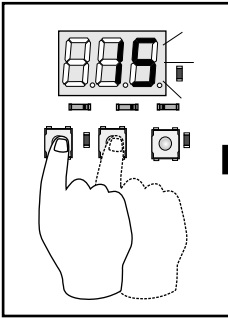

8.5. Use "UP" and "DOWN" buttons to increase or decrease the time value.

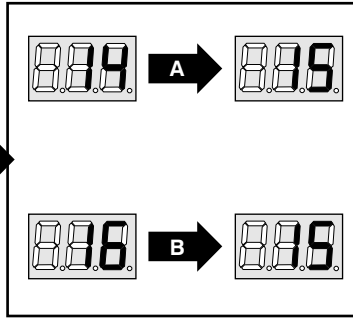

8.6. A - Pressing the "UP" key  
B - Pressing the "DOWN" key

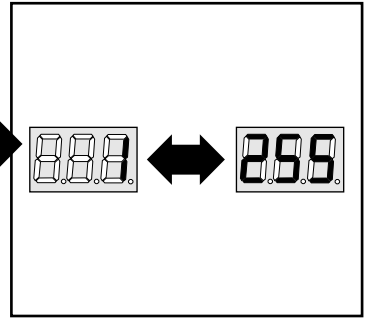

8.7. Programmable range for Auto-Close Override timer is 1 second to 255 seconds

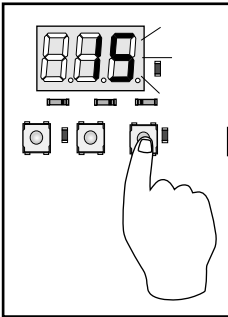

8.8. Press "ENTER" to save the changes

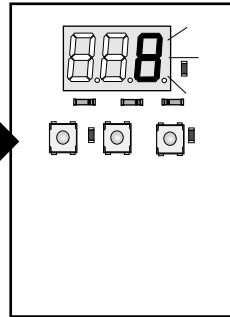

8.9. Returns to the main menu at the same point you were last time



See notes referring to AUTO-CLOSE OVERRIDE TIMER on pg 56



## 9. SAFETY TYPE CONFIGURATION OF BM1 TERMINAL

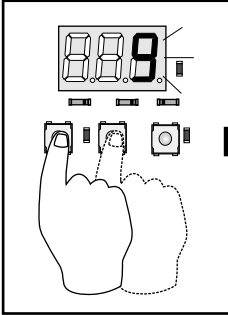

9.1. Scroll until the "9" is displayed, i.e. this menu item

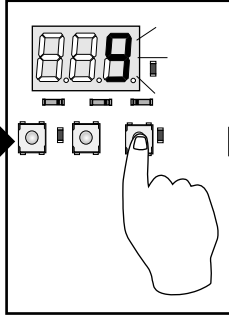

9.2. Press "ENTER" to select it for editing

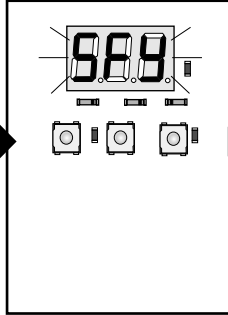

9.3. Menu name is displayed in abbreviated form

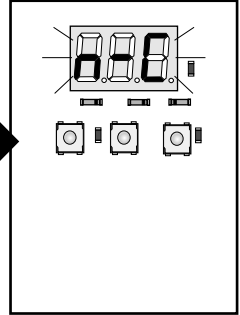

9.4. Current setting for this menu is displayed

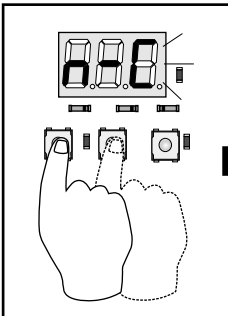

9.5. Use "UP" and "DOWN" buttons to select.

	<b>NORMALLY CLOSED</b> Configured for OPENING beam on BM1 Terminal
	<b>NORMALLY OPEN DELAYED</b> Configured for centrifugal switch motor signal

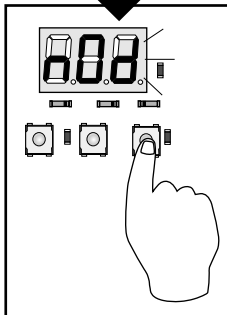

9.6. Press "ENTER" to save the changes

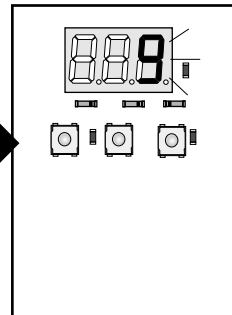

9.7. Returns to the main menu at the same point you were last time



See notes referring to SAFETY TYPE CONFIGURATION OF BM1 TERMINAL on pg 56

## 10. PILLAR LAMP PREFLASHING MODE

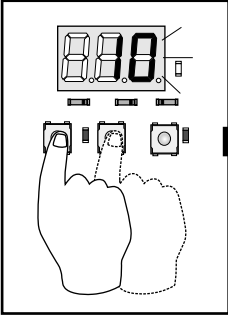

10.1. Scroll until the "10" is displayed, i.e. this menu item

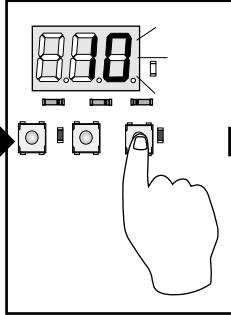

10.2. Press "ENTER" to select it for editing

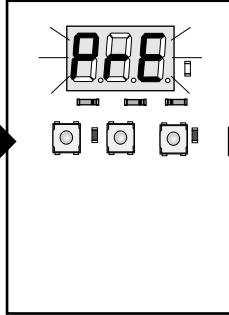

10.3. Menu name is displayed in abbreviated form

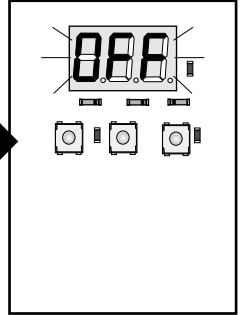

10.4. Current setting for this menu is displayed

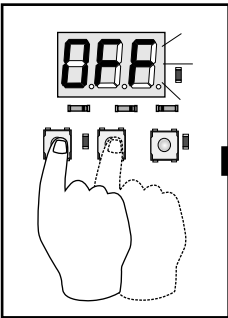

10.5. Use "UP" and "DOWN" buttons to select.

	<p><b>PREFLASHING OFF</b> Pillar Lamp works as a standard courtesy lamp</p>
	<p><b>PREFLASHING MODE A</b> Pillar Lamp is on only when the gates move</p>
	<p><b>PREFLASHING MODE B</b> Lamp flashes for preset time before gate moves, flashes while gate moves</p>
	<p><b>PREFLASHING MODE C</b> Lamp turns on for preset time before gate moves, on while gate moves</p>

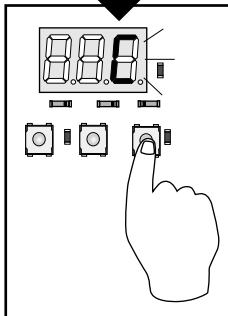

10.6. Press "ENTER" to save the changes

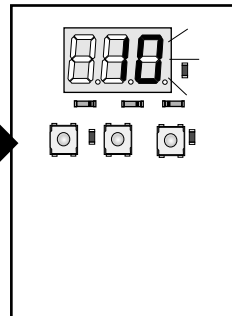

10.7. Returns to the main menu at the same point you were last time



See notes referring to PILLAR LAMP PREFLASHING MODE on pg 57

## 11. PREFLASHING TIME

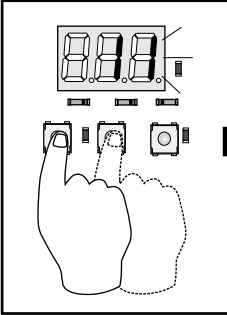

11.1. Scroll until the "11" is displayed, i.e. this menu item

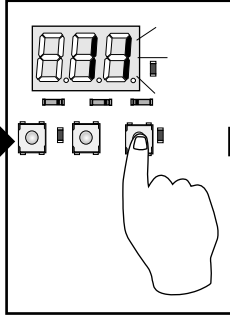

11.2. Press "ENTER" to select it for editing

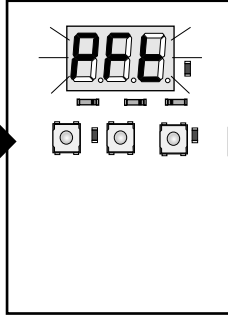

11.3. Menu name is displayed in abbreviated form

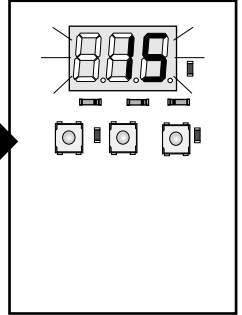

11.4. Current setting for this menu is displayed

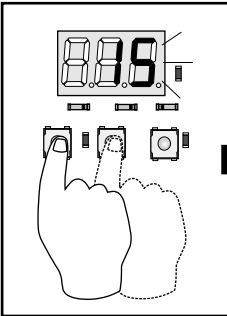

11.5. Use "UP" and "DOWN" buttons to increase or decrease the time value.

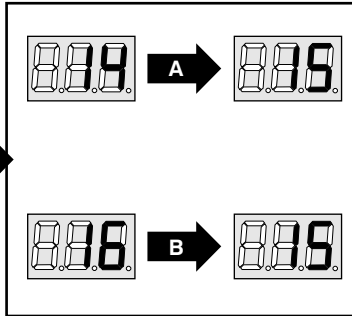

11.6. A - Pressing the "UP" key  
B - Pressing the "DOWN" key

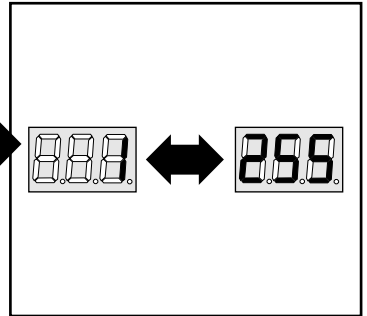

11.7. Programmable range for Pre-flashing time is 1 second to 255 seconds

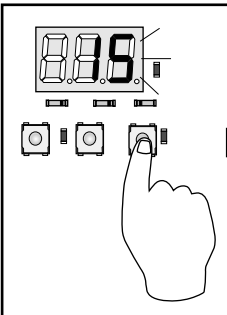

11.8. Press "ENTER" to save the changes

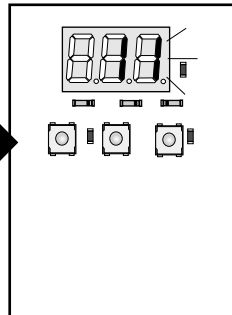

11.9. Returns to the main menu at the same point you were last time



See notes referring to PRE-FLASHING TIME on pg 58

## 12. MOTOR REVERSAL DELAY TIME

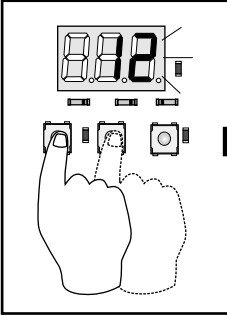

12.1. Scroll until the "12" is displayed, i.e. this menu

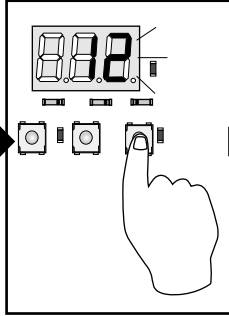

12.2. Press "ENTER" to select it for

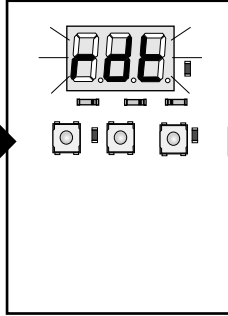

12.3. Menu name is displayed in abbreviated form

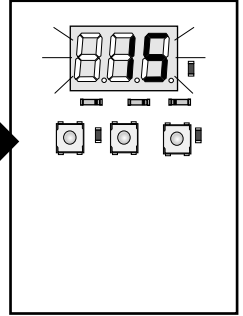

12.4. Current setting for this menu is displayed

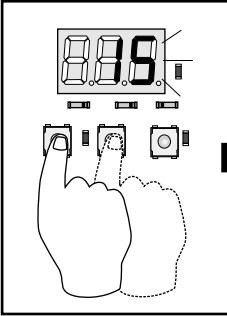

12.5. Use "UP" and "DOWN" buttons to increase or decrease the time value.

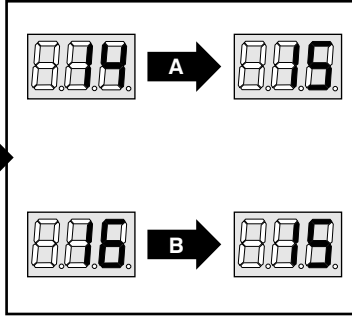

12.6. A - Pressing the "UP" key  
B - Pressing the "DOWN" key

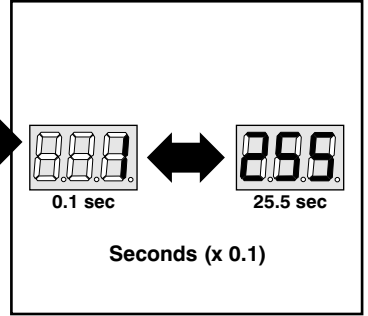

12.7. Programmable range for Reversal Delay Time is 0.1 second to 25.5 seconds. Setting of zero disables reversal delay timer.

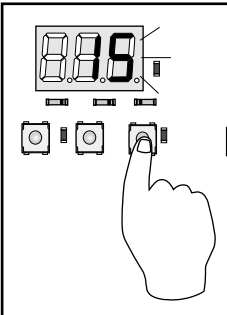

12.8. Press "ENTER" to save the changes

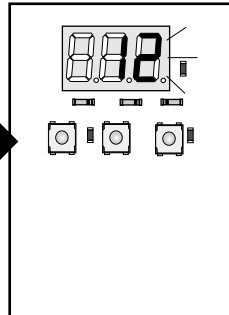

12.9. Returns to the main menu at the same point you were last time



See note referring to MOTOR REVERSAL DELAY TIME on pg 58

### 13. LEAF ORDER SELECTION

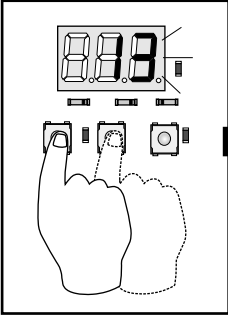

13.1. Scroll until the "13" is displayed, i.e. this menu item

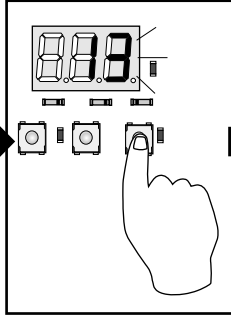

13.2. Press "ENTER" to select it for editing

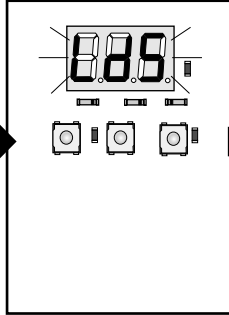

13.3. Menu name is displayed in abbreviated form

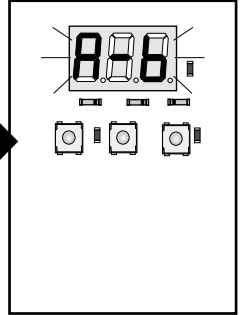

13.4. Current setting for this menu is displayed

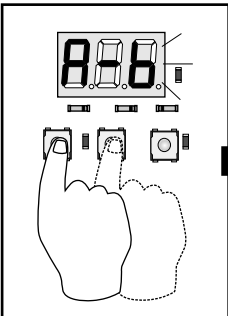

13.5. Use "UP" and "DOWN" buttons to select desired configuration from the available options

	<b>LEAF ORDER A - B</b> Standard Mode of Operation
	<b>LEAF ORDER B - A</b> Reversed Mode of Operation

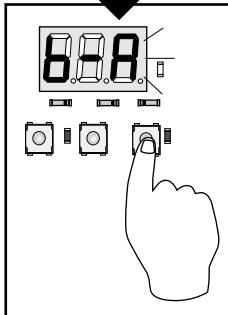

13.6. Press "ENTER" to save the changes

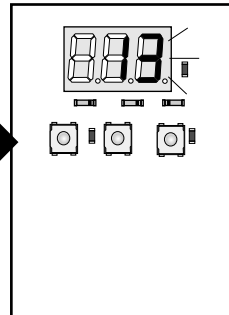

13.7. Returns to the main menu at the same point you were last time



See notes referring to LEAF ORDER SELECTION on pg 58

## 14. LEAF DELAY TIME

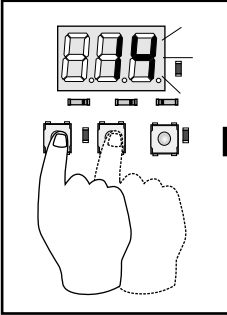

14.1. Scroll until the "14" is displayed, i.e. this menu

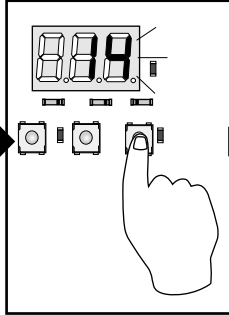

14.2. Press "ENTER" to select it for

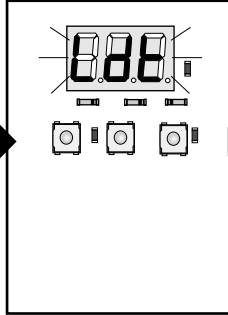

14.3. Menu name is displayed in abbreviated form

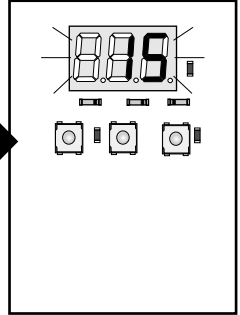

14.4. Current setting for this menu is displayed

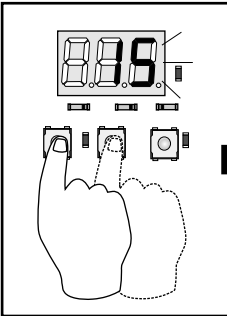

14.5. Use "UP" and "DOWN" buttons to increase or decrease the time value.

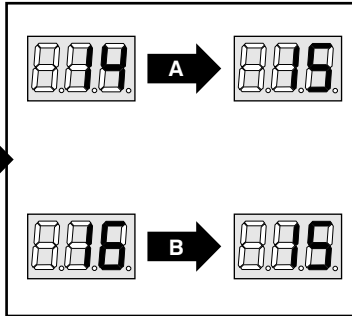

14.6. A - Pressing the "UP" key  
B - Pressing the "DOWN" key

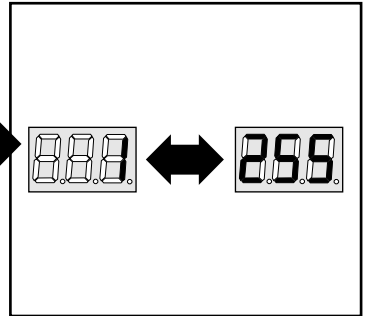

14.7. Programmable range for Leaf Delay Time is 1 second to 255 seconds.  
Leaf delay mode is disabled with a setting of zero.

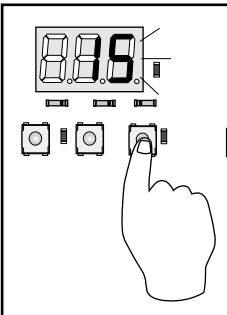

14.8. Press "ENTER" to save the changes

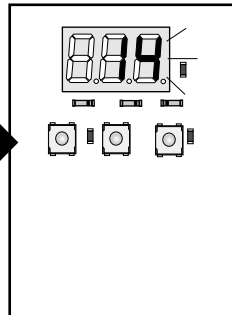

14.9. Returns to the main menu at the same point you were last time



See note referring to LEAF DELAY TIME on pg 58

## 15. SOLENOID TIMER

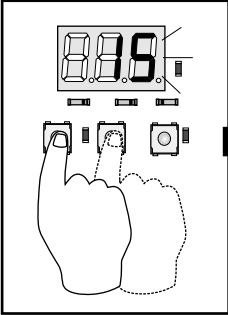

15.1. Scroll until the "15" is displayed, i.e. this menu

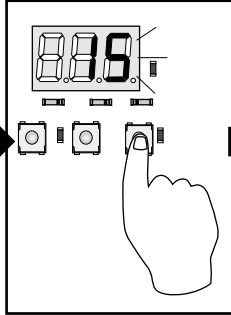

15.2. Press "ENTER" to select it for

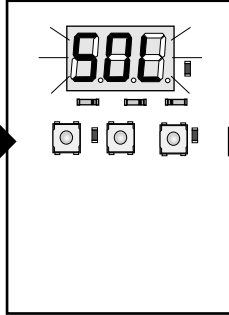

15.3. Menu name is displayed in abbreviated form

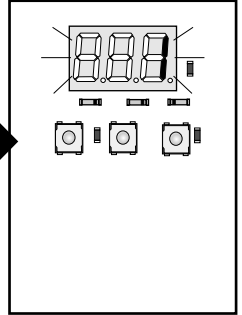

15.4. Current setting for this menu is displayed

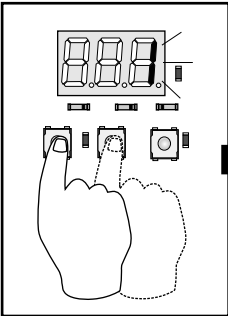

15.5. Use "UP" and "DOWN" buttons to increase or decrease the time value.

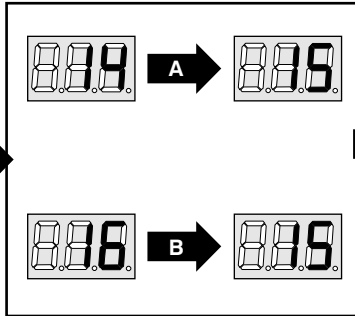

15.6. A - Pressing the "UP" key  
B - Pressing the "DOWN" key

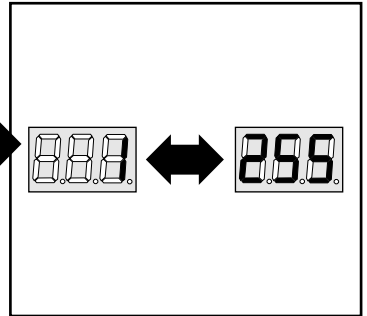

15.7. Programmable range for Solenoid Energise Time is 1 second to 255 seconds.

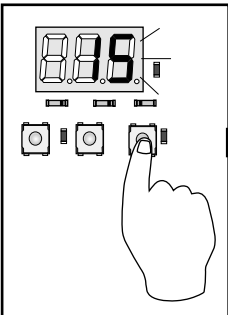

15.8. Press "ENTER" to save the changes

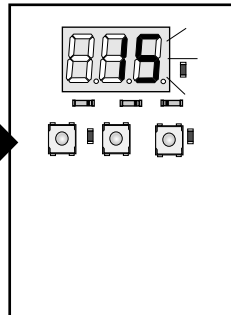

15.9. Returns to the main menu at the same point you were last time



See note referring to SOLENOID TIMER on pg 59

## 16. MASTER MOTOR RUN TIME

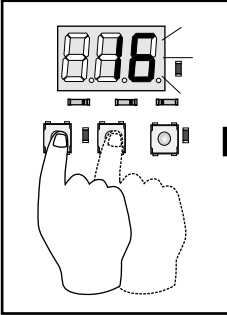

16.1. Scroll until the "16" is displayed, i.e. this menu

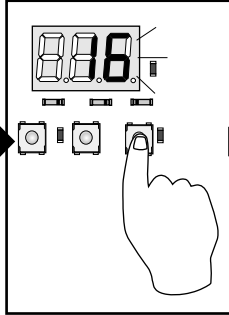

16.2. Press "ENTER" to select it for

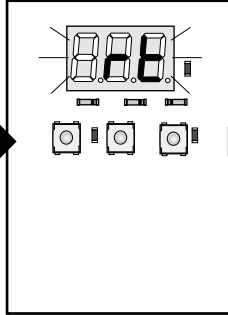

16.3. Menu name is displayed in abbreviated form

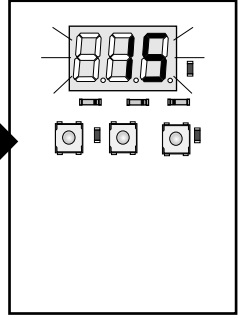

16.4. Current setting for this menu is displayed

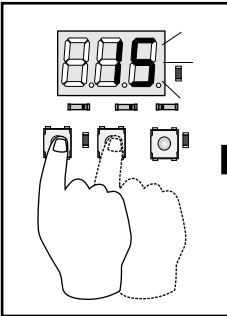

16.5. Use "UP" and "DOWN" buttons to increase or decrease the time value.

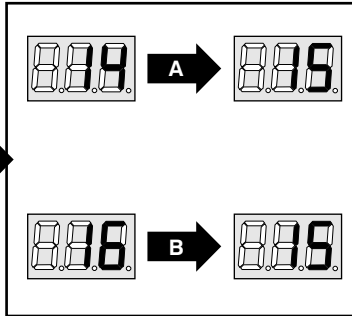

16.6. A - Pressing the "UP" key  
B - Pressing the "DOWN" key

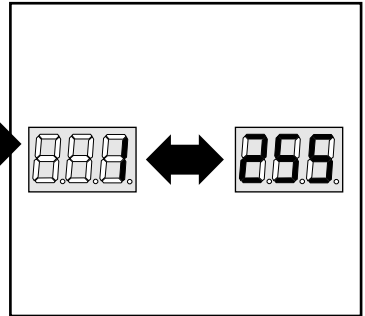

16.7. Programmable range for Master Motor Run Time is 1 second to 255 seconds.

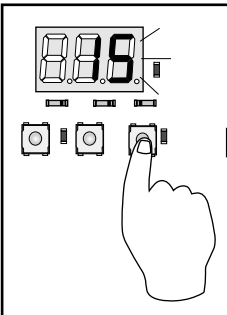

16.8. Press "ENTER" to save the changes

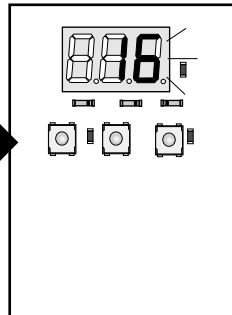

16.9. Returns to the main menu at the same point you were last time



See note referring to MASTER MOTOR RUN TIME on pg 59



## 17. SLAVE MOTOR RUN TIME

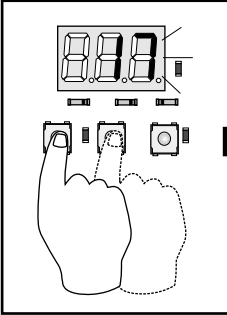

17.1. Scroll until the "17" is displayed, i.e. this menu

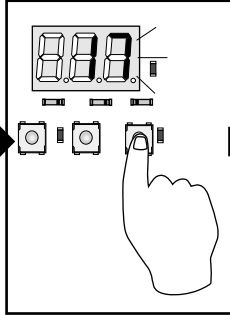

17.2. Press "ENTER" to select it for

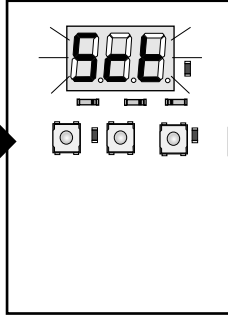

17.3. Menu name is displayed in abbreviated form

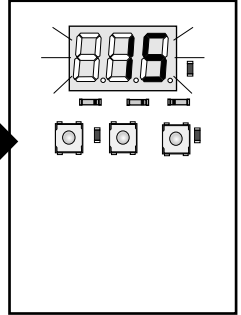

17.4. Current setting for this menu is displayed

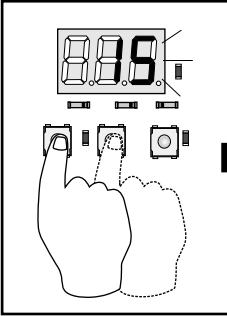

17.5. Use "UP" and "DOWN" buttons to increase or decrease the time value.

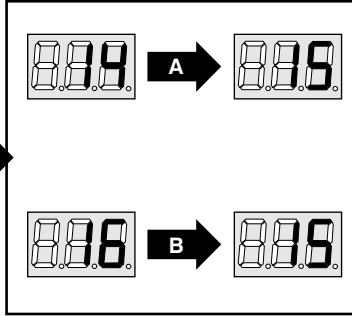

17.6. A - Pressing the "UP" key  
B - Pressing the "DOWN" key

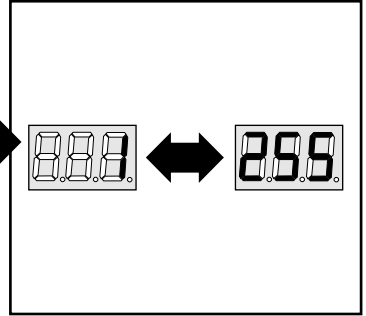

17.7. Programmable range for Slave Motor Run Time is 1 second to 255 seconds.

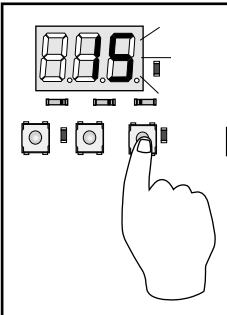

17.8. Press "ENTER" to save the changes

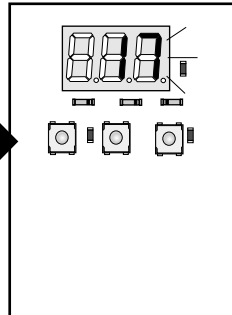

17.9. Returns to the main menu at the same point you were last time



See note referring to SLAVE MOTOR RUN TIME on pg 59

## 18- 21. POWER FACTOR CORRECTIONS

This feature allows you to adjust the power factor of each motor relay to eliminate contact arcing that may manifest itself with some types of AC induction motor used in some types of operator.

Menu Items 18 - 21 are named PF1 - PF4 respectively. Each of these four settings correspond to each of the motor relays on the card such that PF1 is the setting for RL1, and PF2 is the setting of RL2, and so on...

**⚠ WARNING!**

**Incorrect programming of these items may lead to product failure!**

**See the example below: Adjusting PFC of RL2 (MASTER OPENING RELAY)**

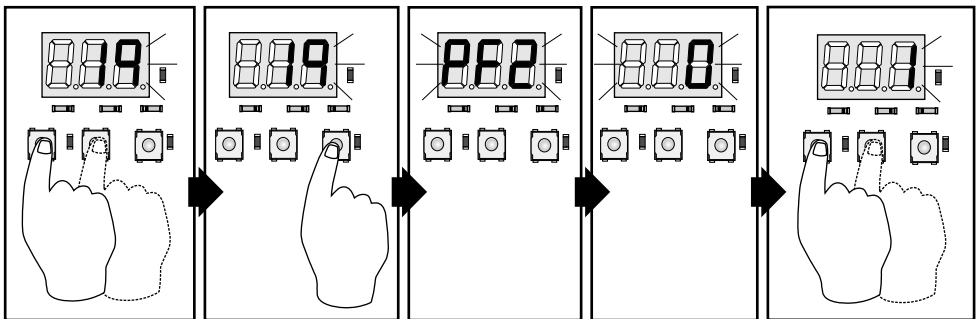

18.1. Scroll until the "19" is displayed, which is the menu number of PF2

18.2. Press "ENTER" to select it for editing

18.3. Menu name is displayed in abbreviated form

18.4. Current setting for this menu is displayed

18.5. Use "UP" and "DOWN" buttons to increase or decrease the PFC value

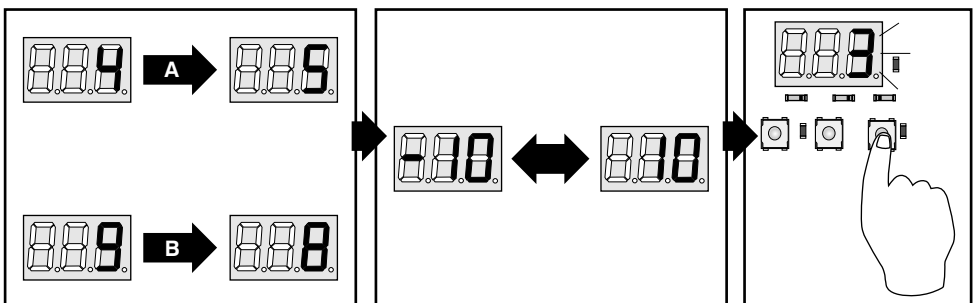

18.6. A - Pressing the "UP" key  
B - Pressing the "DOWN" key

18.7. PFC Adjustment Range -10 to +10 units

18.8. Press "ENTER" to save the changes

## 22. MAINS FREQUENCY

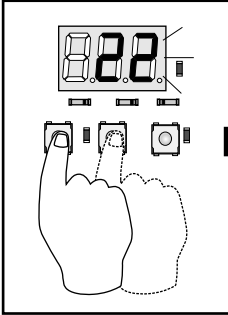

22.1. Scroll until the "2" is displayed, i.e. this menu item

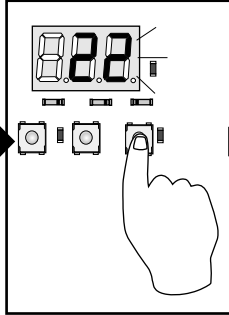

22.2. Press "ENTER" to select it for editing

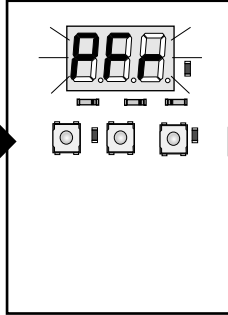

22.3. Menu name is displayed in abbreviated form

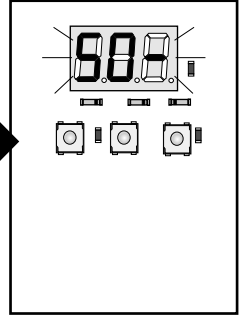

22.4. Current setting for this menu is displayed

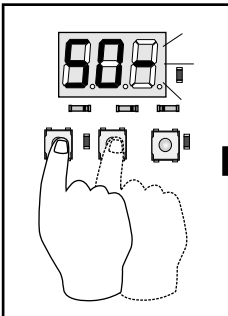

22.5. Use "UP" and "DOWN" buttons to cycle through the options available

	<b>50Hz</b> Mains frequency setting for RSA, UK and most of Europe
	<b>60Hz</b> Mains frequency setting for USA and Canada

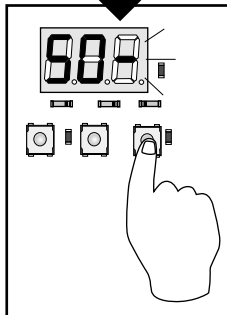

22.6. Press "ENTER" to save the changes

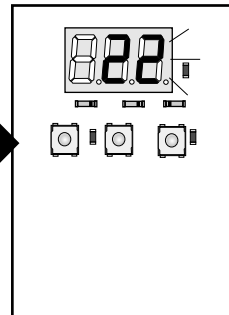

22.7. Returns to the main menu at the same point you were last time

### **WARNING!**

**Incorrect programming of this item may lead to product failure!**

## 23. PEDESTRIAN MODE ERROR COMPENSATION

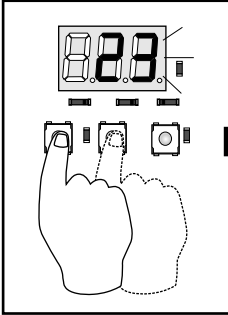

23.1. Scroll until the "16" is displayed, i.e. this menu

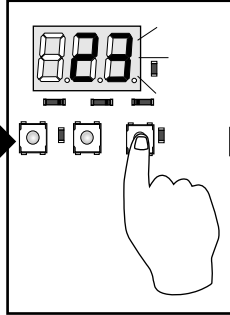

23.2. Press "ENTER" to select it for

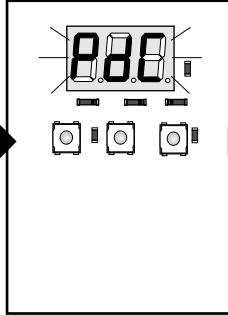

23.3. Menu name is displayed in abbreviated form

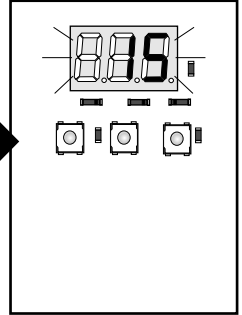

23.4. Current setting for this menu is displayed

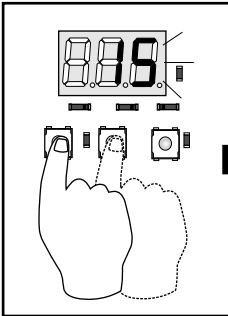

23.5. Use "UP" and "DOWN" buttons to increase or decrease the time value.

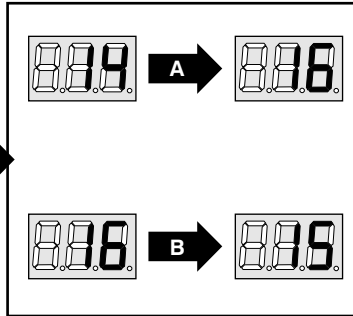

23.6 . A - Pressing the "UP" key  
B - Pressing the "DOWN" key

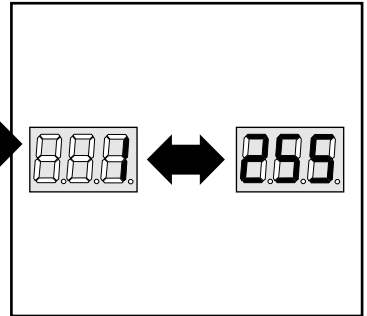

23.7. Programmable range for Pedestrian Compensation Time is 1 second to 255 seconds. A setting of zero disables (turns off) this feature.

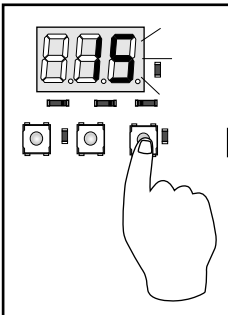

23.8. Press "ENTER" to save the changes

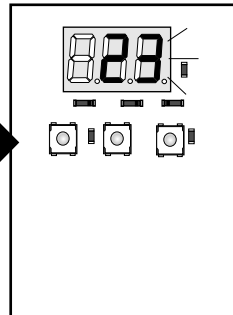

23.9. Returns to the main menu at the same point you were last time



See note referring to PEDESTRIAN MODE ERROR COMPENSATION on pg 60

## 24. POST SOLENOID DELAY TIMER

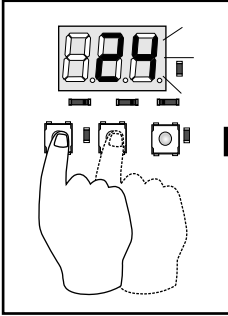

24.1. Scroll until the "16" is displayed, i.e. this menu

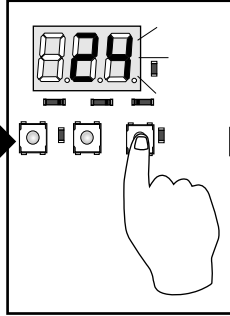

24.2. Press "ENTER" to select it for

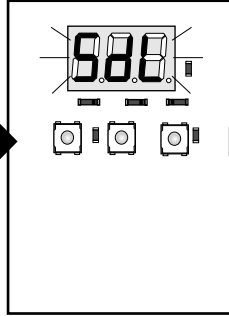

24.3. Menu name is displayed in abbreviated form

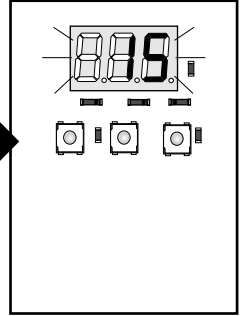

24.4. Current setting for this menu is displayed

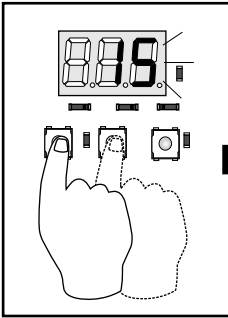

24.5. Use "UP" and "DOWN" buttons to increase or decrease the time value.

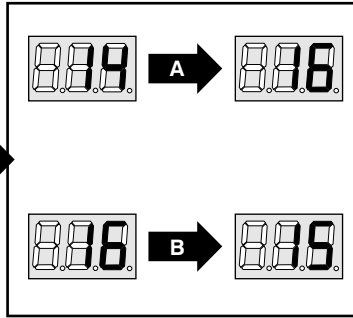

24.6 . A - Pressing the "UP" key  
B - Pressing the "DOWN" key

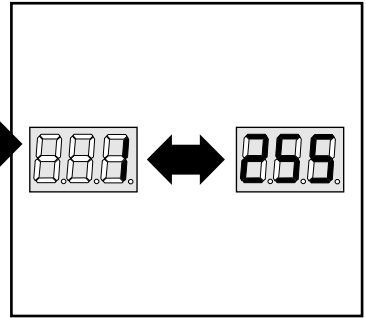

24.7. Programmable range for Post Solenoid Delay Timer is 1 second to 255 seconds. A setting of zero disables this feature.

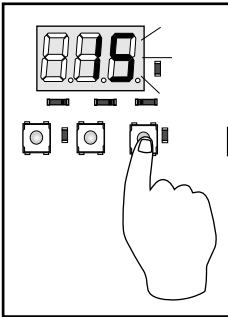

24.8. Press "ENTER" to save the changes

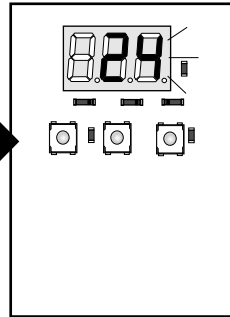

24.9. Returns to the main menu at the same point you were last time



See note referring to  
POST SOLENOID  
DELAY  
on pg 60

## 25. SOLENOID LOCK PRESSURE RELEASE FUNCTION

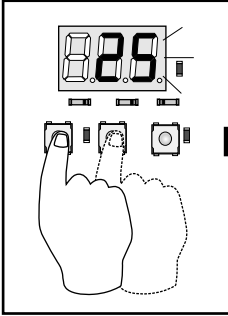

25.1. Scroll until the "13" is displayed, i.e. this menu item

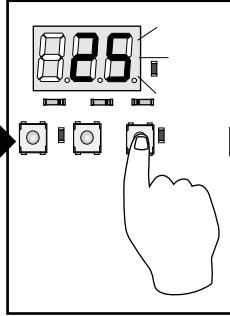

25.2. Press "ENTER" to select it for editing

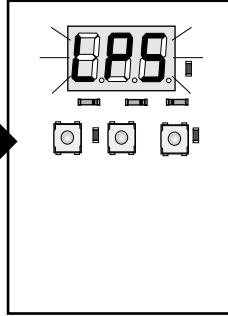

25.3. Menu name is displayed in abbreviated form

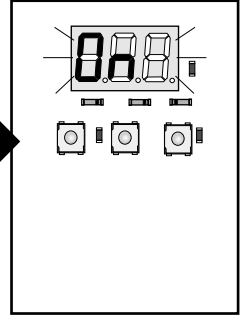

25.4. Current setting for this menu is displayed

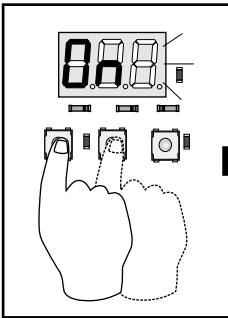

25.5. Use "UP" and "DOWN" buttons to select desired configuration from the available options

	<b>LOCK PRESSURE RELEASE ROUTINE OFF</b> Gate operates in the standard manner
	<b>LOCK PRESSURE RELEASE ROUTINE ON</b> Gates are pulled against limits to relieve strain on lock

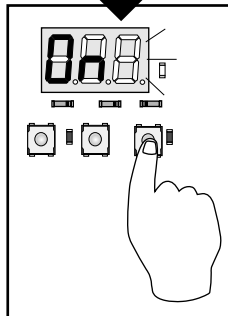

25.6. Press "ENTER" to save the changes

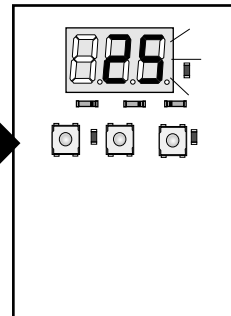

25.7. Returns to the main menu at the same point you were last time



See notes referring to SOLENOID LOCK PRESSURE RELEASE FUNCTION on pg 60

---

# Programming Notes

## 1. LIMIT SWITCH CONFIGURATION

- In FREE RUN configuration, you do not need to fit wire links to the limit switch terminals. It is acceptable to leave them open.

## 2. AUTO-CLOSE FUNCTION

- This feature is forced to the "ON" setting and cannot be changed if the CONDO or PIRAC mode is selected. You will not be able to make changes if these modes are programmed.

## 4. OPERATING MODE

- **PLC and DEADMAN mode require special electrical configurations!** In PLC mode, the TRIGGER and FREE EXIT terminals become the control pulse inputs. The TRIGGER pin accepts CLOSING command pulses, and the FREE EXIT pin accepts OPENING command pulses. The CP93 responds on the falling edge of the pulse. The pulse width must be at least 500ms long.
- In DEAD MAN mode, the TRIGGER and FREE EXIT pins become CLOSE and OPEN signalling inputs respectively. The gate will freeze state, i.e. gate stops completely if a signal should fall away before the gate has reached it's limits.
- PLC and DEAD MAN mode cannot work without limit switches. You must fit limit switches to the motors or gates if these modes are to be used successfully.
- In both the PLC and DEAD MAN mode it is not possible to have a FREE EXIT button because that terminal is then reserved for controlling the gate.
- Selecting either CONDO or PIRAC mode will force AUTO-CLOSE to on the "ON" setting automatically. In these modes it's not possible to turn it off in the menu.

## 5. PEDESTRIAN AUTO-CLOSE TIME

- This timer determines how long the gate will stay open for a pedestrian. Care should be exercised to program it such that the gate does not remain open too long after it has opened for security, but, at the same time must be sufficiently long to allow pedestrians to walk through.

## 6. PILLAR/COURTESY LIGHT TIMER

- This timer determines how long the pillar lamp remains on after a gate cycle has completed. It also specifies the length of on-time when the light control button is pressed.
- In other modes this time is the actual time the lamp remains on, and is not related to pre-flash times, etc.

---

## 7. PEDESTRIAN RUN TIME

- This timer determines how far the MASTER gate will open to allow a space for pedestrians to enter. THIS TIMER MAY NEVER BE EQUAL TO, OR LONGER THAN ANY OF THE MOTOR RUN TIMES. This timer is set typically that the gate will only open to about 30-45 degrees as shown.
- The width of the opening allowed is just sufficient for people to enter. Adjust the pedestrian run time to alter the size of this opening.
- **The closing cycle of the pedestrian mode is such that it will always attempt to close onto the limit switch. In free-run mode the pedestrian run-time applies and may be compensated to be longer than the opening run-time in menu item 23 to cancel out the position error that occurs.**

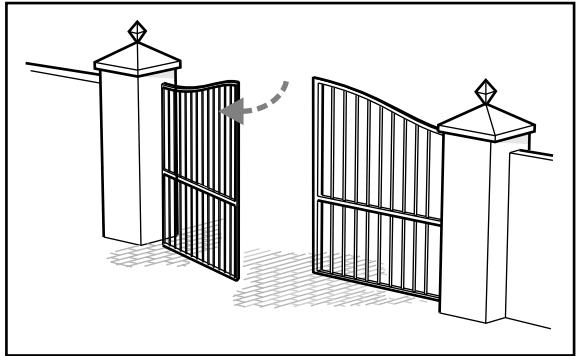

Figure 28 Gate Opening at 30-45°

## 8. AUTO-CLOSE OVERRIDE TIMER

- Setting this timer longer than the run time or cycle time of the gate, or to zero will prevent auto-close override from being invoked. You may do this to disable the ACO feature for security reasons.
- Auto-Close override mode may only be invoked in STANDARD and REVERSING modes.
- Note that this feature only works on a per-cycle basis and is cleared once the gate cycle is completed.

## 9. SAFETY TYPE CONFIGURATION OF BM1 TERMINAL



**NORMALLY CLOSED**  
Configuration for OPENING beam on BM1 Terminal

- In this configuration, connect an opening beam to the BM1 terminal as shown on page 22. If you do not want to use an opening beam, simply fit a wire link between BM1 terminal and COM as shown below.

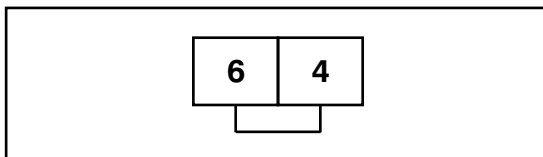

Figure 29 Wire Link



---

## 9. SAFETY TYPE CONFIGURATION OF BM1 TERMINAL continued...



### NORMALLY OPEN DELAYED

Configuration for centrifugal switch motor signal (*HANSA-MATIC, etc.*)

- This is the special mode to accommodate gate motors which have a centrifugal switch. Refer to page 26 for exact wiring details.
- The connections from the switches of both motors may be connected in parallel. The only drawback is that both gates will be reversed if an obstruction is encountered that stalls the motor.
- For newer motors that do not have the centrifugal switch, but have a magnetic pick-up, CENTURION provides an interface module to generate a compatible signal for this pin from the pick-up signal. Please contact CENTURION for more details and availability.

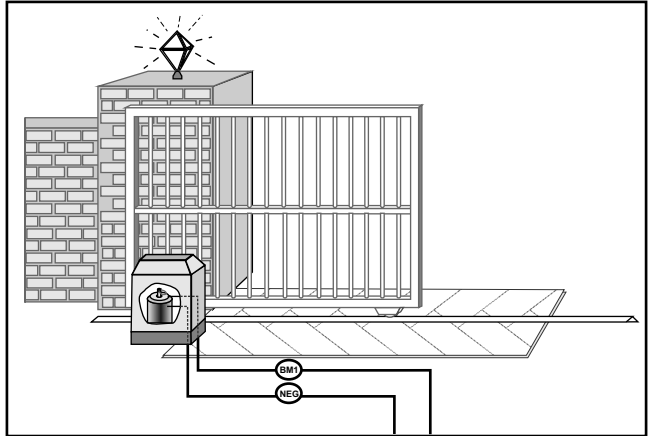

Figure 30 Normally Open Delayed Configuration

## 10. PILLAR LAMP PRE-FLASHING MODE

- **Selecting any of the three pre-flashing modes (A, B or C) disables pillar lamp control via the button input terminal [TERMINAL 11].**

Please note that if you change the pre-flashing setting to "OFF" from a previous setting, the light control button [TERMINAL 11] may only begin to respond after the next gate cycle has occurred.

- Pre-flash MODE A turns the pillar lamp on only when the gate moves, therefore the lamp control relay may be used to control warning lamps or other equipment that may be attached such as barriers, indicators, robots, etc.
- Pre-flash MODE B flashes the lamp for a pre-set amount of time (MENU 11 specifies this amount of time on page 43.) The lamp flashes while the gate moves. When the gate reaches a limit, the lamps stops flashing. In this mode the lamp is intended to be a warning lamp.
- Pre-flash MODE C turns the lamp on for a pre-set amount of time (MENU 11 specifies this amount of time on page 43.) The lamp remains on while the gates move. When the gates reach a limit, the lamp is turned off.

---

## 11. PRE-FLASHING TIME

- Bear in mind that this timer does slow down the response of the gate to user command. This means that the pre-flashing time adds a delay from the time that the trigger is issued to the time that the gate begins to move. Therefore program this value with care.
- This value also determines how long the lamp flashes for warning when the gate is opened in the PEDESTRIAN mode. Setting it to zero disables the pre-flashing function for both the operating modes and pedestrian mode.

## 12. MOTOR REVERSAL DELAY TIME

- This value depends on the characteristics of the operator motors used. The factory default value is generally sufficient. If you have problems with motor reversals, ie. motor takes a long time to stop after power is removed, you may have to adjust this setting to a larger value. A setting of zero disables reversal delay and is useful for certain special applications of the CP93.

## 13. LEAF ORDER SELECTION

- **This mode allows the leafing order of a given gate in an existing installation to be retrofitted with a different locking mechanism. This setting would allow you to change which gate opens first!** The standard setting of A-B mode is the normal order, which means that the MASTER motor is driven first, then the SLAVE motor.
- The alternate setting, i.e. B-A, would result in the SLAVE motor being driven FIRST, followed by the MASTER motor.

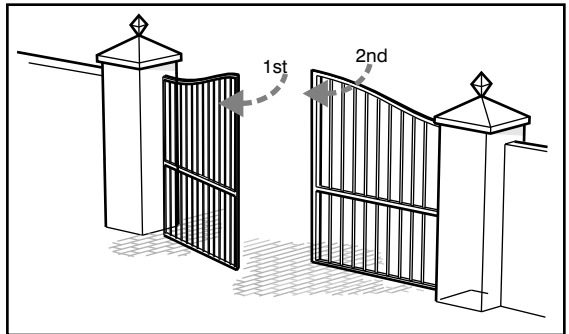

Figure 31 Leaf Order Selection

Assuming the left gate's operator is connected to terminals DEF (MASTER MOTOR) on the CP93, the leaf order shown in the sketch is what will happen in A-B mode. If you select B-A mode, the opposite will happen. The rightmost gate in the above sketch will move first.

**DO NOT ATTEMPT TO RE-ASSIGN THE LIMIT SWITCHES TO AN OPPOSITE MOTOR. THE CP93 IS DESIGNED TO ASSOCIATE THE MASTER LIMIT SWITCHES WITH THE MASTER**

## 14. LEAF DELAY TIME

- This value determines the delay of the one gate behind the other. See run time programming section for details.
- The delay must be checked by testing the system once the CP93 is completely installed. Too short a delay could cause damage to the gate, since the MASTER gate may not have sufficiently cleared the slave gate so soon after it has started moving.
- In many applications, leaf delay is not necessary and may be disabled by setting this option to zero.

---

## 15. SOLENOID TIMER

- This value determines the length of time the solenoid is operated when the gate is opened. The solenoid will only be activated once per cycle and always at the start of the cycle, i.e. when opening the gate from fully closed. The point at which the timer starts taking effect is always when at the point when motors are activated. The special features such as the POST-SOLENOID DELAY mode do not affect this timer.
- Measure the time it takes from the instant power is applied to the motor, until the motor clears the slave gate. This is the time needed to operate the solenoid lock to ensure that the master gate is unlocked from the slave gate.

## 16 & 17. MASTER & SLAVE MOTOR RUN TIME

- **These timers provide individual programming of the MASTER and SLAVE motor run times. Motor run time is defined as the actual time the motor spends operating and is not affected nor offset by leaf delays or any other settings such as pre-flashing modes.**

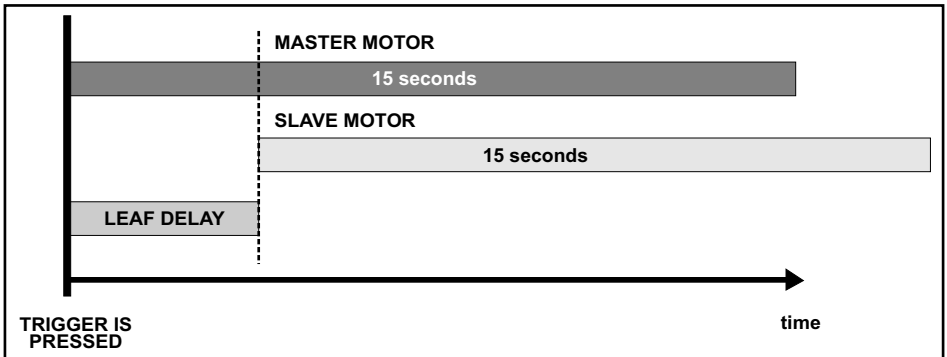

*Figure 32 Time-Line : Leaf Delay offsetting Individual Motor Cycles*

In the above time-line it is clearly illustrated how the leaf delay offsets the individual motor cycles. If leaf delay is disabled for the above example, both motors stop at the same time.

This system allows you to set the end stop anywhere you like, especially useful in scenarios where one gate opens more fully than the other due to some kind of obstruction such as a rock, siding, bird bath, ornament, etc.

## 18 - 21. POWER FACTOR CORRECTIONS

- Programming the PF value to zero means the factory default setting is used. If you are in any doubt, it is better to set the PF value to zero and work from there. Enough range is provided for the user to experiment.

### **How to determine the optimal value for PF:**

Adjust the PF value in steps of 1 at a time, beginning at (-10) and observe the effect on the relay. The closer you get to the optimal setting, the smaller the arc across the contacts will become. The optimal setting is the one that, when incremented by one, produces severe relay arcing.

---

The moment you see severe arcing, simply adjust the PF value back one notch. This is the optimal setting. Note in some cases you may not eliminate the spark completely but you will be able to reduce it to an insignificant amount that will not be detrimental to the life of the relay contacts. In practice it has been observed that if the relay arcing cannot be eliminated, there is a problem with the motor's start capacitor. You are well advised to ensure that the capacitor of each motor is of the correct type, is in good working order and is connected correctly.

### **23. PEDESTRIAN MODE COMPENSATION**

This value allows the installer to lengthen the closing run time of the pedestrian gate to compensate for positioning error that occurs as a result of the gate running on for a short distance after it was stopped and other factors. This is usually in cases where the unit is programmed in FREE RUN mode but has no effect when limit switches are used as the CP93 will close the gate onto the limit. A setting of zero disables this feature.

### **24. POST SOLENOID DELAY**

This function provides a programmable delay between the time that the solenoid lock operates and the gate begins to move. This is used primarily to allow motorised locks sufficient time to open and prevents the gates from moving while the lock is operating. A setting of zero disables this function.

### **25. SOLENOID LOCK PRESSURE RELEASE FUNCTION**

This feature is a special routine that is performed every time the gate is commanded to open when fully closed. The gates are driven forward momentarily into their closed limits while the solenoid lock operates. This removes the mechanical pressure on the lock, so that it can operate easily. This is particularly useful for very heavy gates that are on a slight incline.

## Appendix A: Resetting the product to the factory default settings

If, for any reason it becomes necessary to reset the CP93 to the factory default settings, the following procedure may be followed to clear all memory and reset the entire product.

**⚠ WARNING!**

**ALL USER SETTINGS  
ARE LOST IF THIS  
PROCEDURE IS  
PERFORMED.**

### Step 1: POWER DOWN THE CARD

Isolate the mains or simply unplug the connector.

### Step 2: CONNECT TRIGGER, FREE EXIT AND LIGHT TO COMMON

Connect the TRIGGER, FREE EXIT and LIGHT inputs together as shown. Remove the original wires to do this.

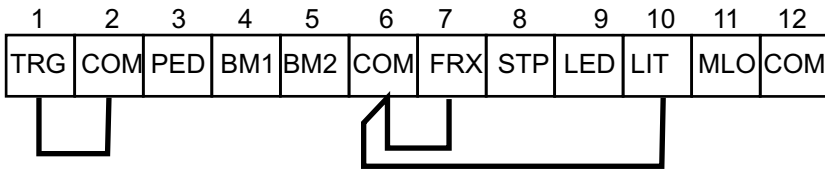

### Step 3: POWER-UP THE CARD

Within seconds the CP93 will display "dEF". This signals that the EEPROM has been loaded with the factory default values.



### Step 4: POWER-DOWN THE CARD AND REMOVE THE LINKS

Remove power from the CP93 once again and remove the wire links shown above. You may now re-attach the original wires.

### Step 5: POWER UP THE CARD

The CP93 resumes normal operation. Accessing the menus will reveal that the settings are set to the default values.

---

## Appendix B: Determining the Firmware Revision

The CP93 displays its firmware revision level every time the card is powered up. It is important to know the firmware revision as newer revisions may be available that address customer complaints, or provide new functionality. Contact CENTURION for details on firmware upgrade policy and procedures. Products sent in for repair are upgraded with the latest firmware.

When the CP93 is powered up, it displays the firmware revision on the display as follows:

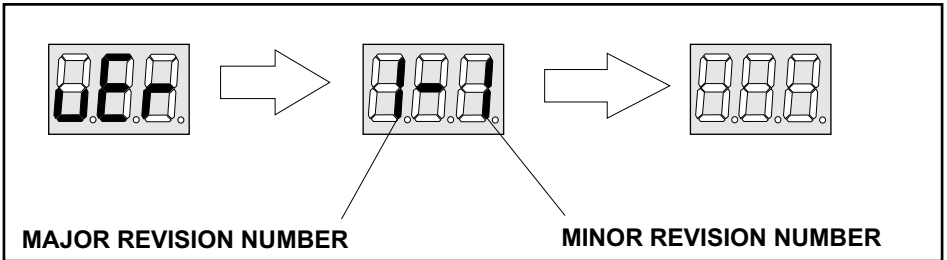

*Figure 33 Firmware Revision Display*

The MAJOR REVISION NUMBER and MINOR REVISION NUMBER are documented in the format of "V1.1" so therefore from the above it follows that the above displays shows V1.1. This is the format you should use in all correspondence with CENTURION SYSTEMS for queries or information about product firmware.

---

## Appendix C: System Errors

The CP93 provides safe trapping of serious system faults.

### **DATA CORRUPTION / MEMORY FAILURE**

Corruption of the CP93 memory, which may be caused by electrostatic discharge and severe lightning strikes will cause the firmware to load default values after it has reset itself. In a situation like this you will typically find the product displays "dEF" but does not function. In this case you should proceed as follows:

- Reprogram customer's settings and power-cycle the CP93. The "dEF" message should clear and normal operation resumes.

If the card persistently displays "dEF" i.e. the message is displayed permanently with power applied and does not clear after repeated power cycling, this indicates memory failure. Return the card to CENTURION SYSTEMS for repair.

### **MOTOR JAM / EXCESSIVE COLLISIONS**

This applies to the "NORMALLY OPEN DELAYED" mode of operation, i.e. motors with governors. This message, accompanied with loss of functionality will be displayed when the motor becomes jammed and the system has tried unsuccessfully to free the motor after 6 attempts. The card flashes the STATUS LED in cycles of five flashes, and the "Er1" is displayed on the card.

To recover from this error:

Resolve the motor jam, then power-cycle the card. Normal operation will resume.

### **OTHER ERROR MESSAGES**

In case of other error messages, please contact CENTURION SYSTEMS or send the card in for repair with a detailed report attached, detailing under what circumstances the error occurred, the nature of the site/installation and full contact details.



# CENTURION

**THE AUTOMATIC CHOICE**



---

CENTURION SYSTEMS (PTY) LTD HEAD OFFICE:  
TEL: +27 (0)11 699-2400, FAX: +27 (0)11 704-3412 or 462-6669  
148 EPSOM AVENUE, NORTH RIDING  
P.O. BOX 506, CRAMERVIEW, 2060  
SOUTH AFRICA

WEB: <http://www.centsys.co.za> General information e-mail: [info@centsys.co.za](mailto:info@centsys.co.za)

---

## FOR TECHNICAL SUPPORT CONTACT:

### SOUTH AFRICA

EAST RAND .....	(011) 397-6401	PORT ELIZABETH .....	(041) 581-6994/5
DURBAN .....	(031) 701-9583	EAST LONDON .....	(043) 743-4923
NELSPRUIT .....	(013) 752-8074/5	BLOEMFONTEIN .....	(051) 448-1714
PRETORIA .....	(012) 362-8819/8893	KIMBERLEY .....	(053) 832-3231
CAPE TOWN .....	(021) 447-1295	VEREENIGING .....	(016) 422-5667

### AFRICA

ECHO-LINE, NAMIBIA .....	Tel: (61) 220-8309
MOLECULAR CONSULTANTS, NIGERIA .....	Tel: 803-3123182
SECURITY DISTRIBUTORS, ZIMBABWE .....	Tel: (4) 795-873
SEKANYOLYA TIMBER WORKS, UGANDA .....	Tel: (41) 231-40

### EUROPE

AUTOMATISME BATIMENT, FRANCE .....	Tel: (1) 697-93120
CROWN AXCESS LTD U.K. UNITED KINGDOM .....	Tel: (1483) 450-011
NESTOR, BELGIUM .....	Tel: (9) 380-4020

### NORTH AMERICA

BILLY GATES, CANADA .....	Tel: (250) 334-1553
---------------------------	---------------------

### AUSTRALASIA

ABA GATES, WESTERN AUSTRALIA .....	Tel: (8) 933-03061
DOMINATOR SYSTEMS, NEW ZEALAND .....	Tel: (3) 384-5145
ICBT, VICTORIA .....	Tel: (3) 933-54213
ROTECH, QUEENSLAND .....	Tel: (7) 326-47330
SA GATES, SOUTHERN AUSTRALIA .....	Tel: (8) 826-64235
SECURITE DU PACIFIQUE, NEW CALEDONIA .....	Tel: 283-760

### INDIAN OCEAN

SECULOGIX LTD, MAURITIUS .....	Tel: 467-8509
SECURITE AUTOMATISMES REUNION, REUNION .....	Tel: 280-368

### ASIA & PACIFIC

VAST VIDEO, MALAYSIA .....	Tel: (3) 214-34931
BLT ASSOCIATES, THAILAND .....	Tel: (2) 691-6793