

MMnet01

Ethernet Minimodule

User's Manual

REV 1.2

PROPON®

Many ideas one solution

Contents

1 INTRODUCTION	3
APPLICATIONS	4
FEATURES	4
2 CONSTRUCTION OF THE MODULE	4
BLOCK DIAGRAM	4
MODULE PIN-OUT	6
ATMEGA128 MICROCONTROLLER	12
ETHERNET CONTROLLER RTL8019AS	12
MEMORY CONTROLLER	13
RAM MEMORY	14
DATAFLASH MEMORY	14
RESET CIRCUIT	15
LED DIODES	15
3 CONNECTION OF THE MODULE WITH THE EXTERNAL WORLD	16
CONNECTION TO THE ETHERNET NETWORK	16
RS-232 INTERFACE	17
RS-485 INTERFACE	17
USB INTERFACE	18
RADIO LINK	18
LCD DISPLAY	19
4 PROGRAMMING THE MODULE	19
ISP CONNECTOR	19
JTAG CONNECTOR	21
5 AN APPLICATION EXAMPLE	22
6 EVALUATION BOARD	22
7 SPECIFICATIONS	23
8 TECHNICAL ASSISTANCE	23
9 GUARANTEE	23
10 ASSEMBLY DRAWINGS	24
11 DIMENSIONS	25
12 SCHEMATICS	25

Introduction

Thank you very much for having bought our minimodule **MMnet01**. It was created with the idea of facilitating the communication of microprocessor systems through the Internet/Ethernet networks.

The heart of the module is the RISC Atmega128 microcontroller with 128kB of program memory and 64kB of (external) RAM memory, co-operating with the Ethernet RTL8019AS controller (10BaseT). The minimodule has an 512kB DataFlash serial memory for storage of WWW pages and of any files e.g. with measurement data. The memory is connected to a fast SPI bus with 8 Mb/s transmission speed.

MMnet01 operates under real-time control **RTOS** allowing to build applications with the use of pseudo-concurrency in which different tasks are started and executed in the form of separate threads. This permits an easy construction of applications which require parallel execution of several tasks, for example servicing the TCP/IP stack and realizing the algorithm of control of an industrial process. The RTOS system has an extended interface for handling peripheral equipment, thanks to which the communication with them occurs via drivers registered in the system. The system has drivers for the Ethernet controller, serial ports, the 1-Wire bus, the DS 1820 thermometer, LCD display RTC clock and DataFlash memory. The kernel of the RTOS system and the TCP/IP stack together with implemented DHCP, UDP, ICMP, SMTP protocols and HTTP with simple CGI-s were compiled to libraries.

The system incorporates a series of demonstration applications (WWW server, FTP, Telnet, TCP client, TCP server, temperature monitoring and control, applications in the RTOS system) which are basing on completed functions present in the IP stack and RTOS operating system libraries. Attached libraries permit independent experiments (e.g. creation of web pages using the CGI technique without penetrating the lower layers of the IP stack and the RTOS operating system).

The **MMnet01** is delivered loaded with the WWW Server application and WWW demonstration pages with examples of using CGI and Flash. The configuration of the server (MAC address, IP, gateway, change of WWW page) can be effected remotely through serial RS232 or FTP ports.

Sources in C-language and ready libraries are attached to the server; they can be used to realize one's own projects. To modify and compile, the free C-compile GCC or C-compiler from ImageCraft can be put into use.

We wish you nothing but success and a lot of satisfaction in designing and developing new electronic equipment based on the MMnet01 minimodule.

Applications

The **MMnet01** minimodule can be used as a design base for electronic circuits co-operating from the Ethernet/Internet network, covering the following areas of interest:

- Industrial remote controlling and monitoring systems
- Telemetry
- Intelligent buildings
- Alarm systems
- Weather stations and environment monitoring
- Medical electronics
- Heating and air-conditioning systems
- Telecommunication
- Road traffic monitoring
- Remote data logging
- Home automation

The **MMnet01** minimodule can be also used in didactic workshops of information and electronic schools, illustrating the aspects of co-operation of electronic circuits from the Ethernet/Internet network, as well as be used to construct thesis circuits.

Features

- Fast RISC microcontroller ATmega128 with up to 16 MIPS throughput
- Ethernet controller IEEE 802.3 10Mb/s
- 128kB of in circuit programmable FLASH program memory
- 64KB of RAM memory
- 4kB of EEPROM memory
- Serial DataFlash memory 4Mbits (512kBytes)
- Reliable reset circuit
- Crystal resonator 14.7456 or 16 MHz
- 4 LED diodes indicating: power, LAN activity, DataFlash activity
- Fully SMD made on 4-layer PCB
- 1 x 20 terminals with 0.1" (2.54mm) pitch fitting every prototype board
- Available free operating system with TCP/IP stack supporting many protocols
- Available evaluation board and sample applications
- Small dimensions: 56mm x 30.5mm

2 Construction of the module

Block diagram

The block diagram of the MMnet01 minimodule is shown in the drawing:

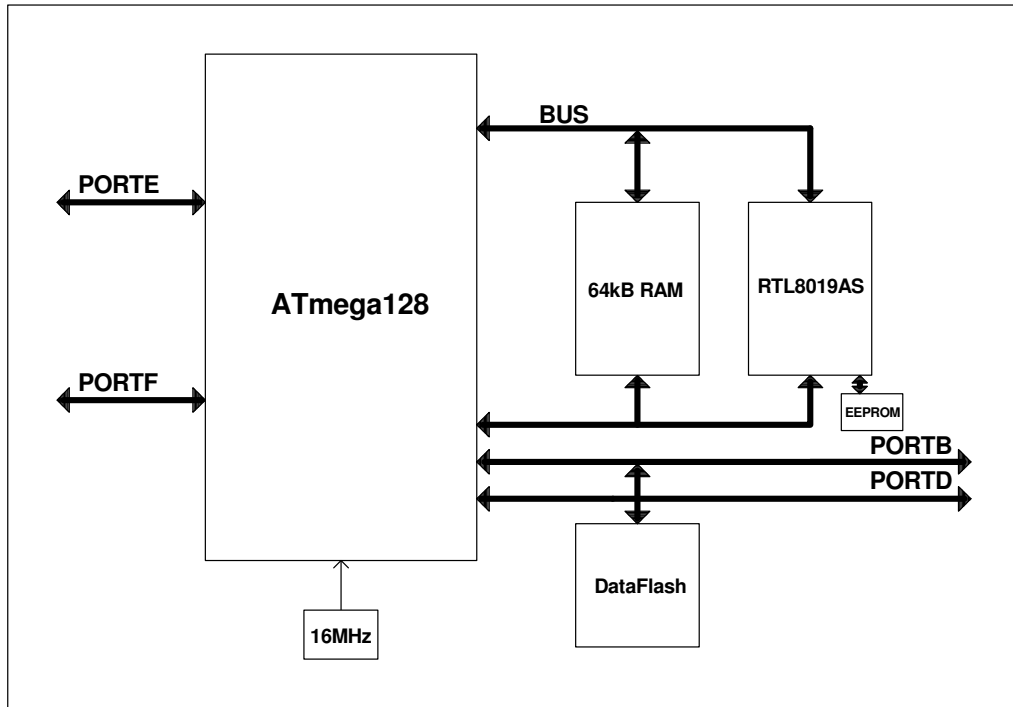

Figure 1 Block diagram of the MMnet01 minimodule.

The minimodule is sold in two basic versions, denoted with letters A and B, or in accordance with individual orders.

Module **MMnet01- A** contains:

- ATmega128 microcontroller
- RAM memory
- Ethernet controller RTL8019AS

Module **MMnet01- B** contains:

- ATmega128 microcontroller
- RAM memory
- Ethernet controller RTL8019AS
- DataFlash 4Mb (512kB) memory

Individual orders coding:

MMnet01 - r - f - x - e - c

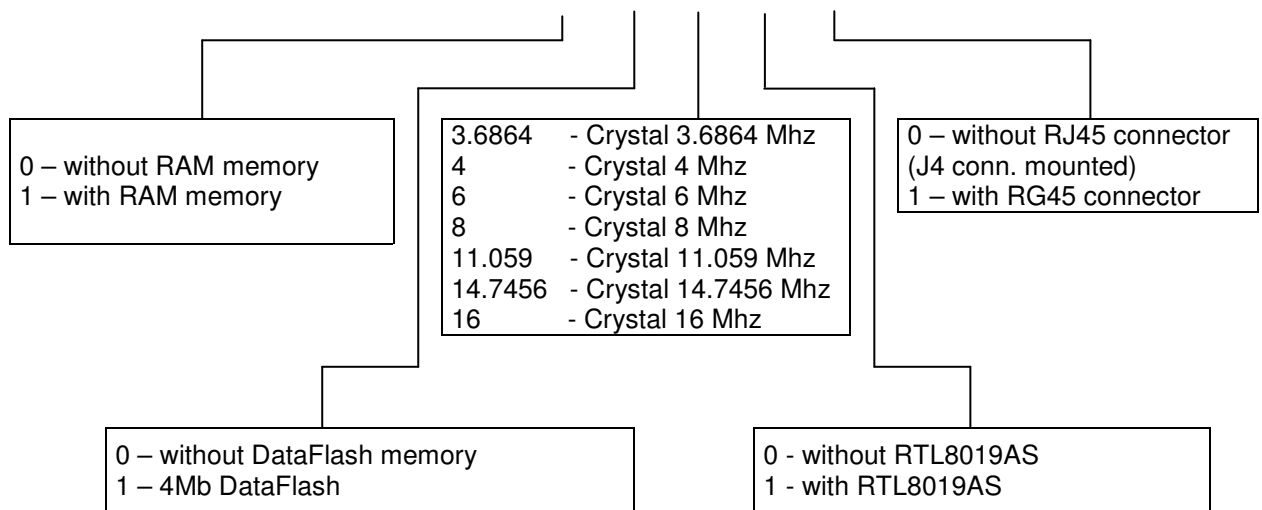

Module pin-out

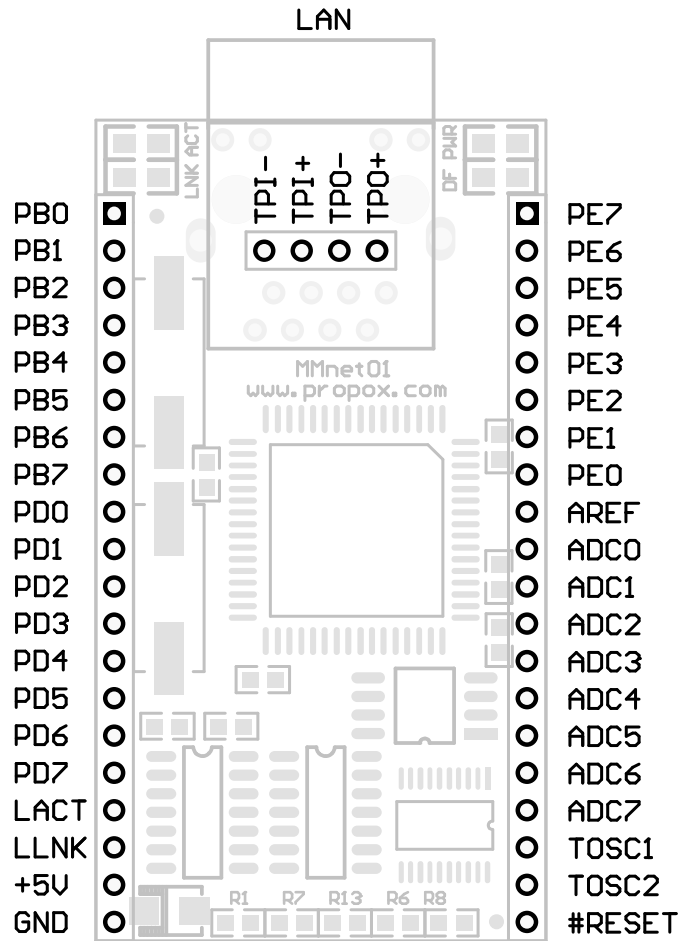

Figure 2 Module pin-out – top view.

Function in MMnet01	Name	J1	J1	Name	Function in MMnet01
	PB0/#SS	1	1	PE7/ INT7	
DataFlash – SCK	PB1/ SCK	2	2	PE6/ INT6	
DataFlash – MOSI	PB2/MOSI	3	3	PE5/ INT5	Przerwanie z RTL8019AS
DataFlash – MISO	PB3/ MISO	4	4	PE4/ INT4	
	PB4/OC0/PWM0	5	5	PE3/ AC-	
DataFlash – #CS	PB5/ OC1A/PWM1A	6	6	PE2/ AC+	
	PB6/OC1B/PWM1B	7	7	PE1/ PDO/TxD	
	PB7/ OC2/PWM2	8	8	PE0/ PDI/RxD	
	PD0/#INT0/SCL	9	9	AREF	
	PD1/#INT1/SDA	10	10	PF0/ ADC0	
	PD2/#INT2/RxD1	11	11	PF1/ ADC1	
	PD3/#INT3/TxD1	12	12	PF2/ ADC2	
	PD4/ IC1	13	13	PF3/ADC3	
	PD5	14	14	PF4/ ADC4/TCK	
	PD6/ T1	15	15	PF5/ ADC5/TMS	
	PD7/T2	16	16	PF6/ ADC6/TDO	
	LEDACT	17	17	PF7/ ADC7/TDI	
	LEDLINK	18	18	TOSC1/PG4	
	+5V	19	19	TOSC2/PG3	
	GND	20	20	#RESET	

J1			
No.	Function	Alt. function	Description
1	PB0	#SS	<p>PB0 – general purpose digital I/O</p> <p>Alternative functions:</p> <p>SS – Slave Port Select input. When the SPI is enabled as a slave, this pin is configured as an input regardless of the setting of DDB0. As a slave, the SPI is activated when this pin is driven low. When the SPI is enabled as a master, the data direction of this pin is controlled by DDB0. When the pin is forced to be an input, the pull-up can still be controlled by the PORTB0 bit.</p> <p>Table 31 and Table 32 relate the alternate functions of Port B to the overriding signals shown in Figure 33 on page 67. SPI MSTR INPUT and SPI SLAVE OUTPUT constitute the MISO signal, while MOSI is divided into SPI MSTR OUTPUT and SPI SLAVE INPUT.</p>

2	PB1	SCK	<p>PB1 – general purpose digital I/O</p> <p>Alternative functions:</p> <p>SCK – Master Clock output, Slave Clock input pin for SPI channel. When the SPI is enabled as a slave, this pin is configured as an input regardless of the setting of DDB1. When the SPI is enabled as a master, the data direction of this pin is controlled by DDB1. When the pin is forced to be an input, the pull-up can still be controlled by the PORTB1 bit.</p>
3	PB2	MOSI	<p>PB2 – general purpose digital I/O</p> <p>Alternative functions:</p> <p>MOSI – SPI Master Data output, Slave Data input for SPI channel. When the SPI is enabled as a slave, this pin is configured as an input regardless of the setting of DDB2. When the SPI is enabled as a master, the data direction of this pin is controlled by DDB2. When the pin is forced to be an input, the pull-up can still be controlled by the PORTB2 bit.</p>
4	PB3	MISO	<p>PB3 – general purpose digital I/O</p> <p>Alternative functions:</p> <p>MISO – Master Data input, Slave Data output pin for SPI channel. When the SPI is enabled as a master, this pin is configured as an input regardless of the setting of DDB3. When the SPI is enabled as a slave, the data direction of this pin is controlled by DDB3. When the pin is forced to be an input, the pull-up can still be controlled by the PORTB3 bit.</p>
5	PB4	OC0/PWM0	<p>PB4 – general purpose digital I/O</p> <p>Alternative functions:</p> <p>OC0 – Output Compare Match output: The PB4 pin can serve as an external output for the Timer/Counter0 Output Compare. The pin has to be configured as an output (DDB4 set (one)) to serve this function. The OC0 pin is also the output pin for the PWM mode timer function.</p>
6	PB5	OC1A/PWM1A	<p>PB5 – general purpose digital I/O</p> <p>Alternative functions:</p> <p>OC1A – Output Compare Match A output: The PB5 pin can serve as an external output for the Timer/Counter1 Output Compare A. The pin has to be configured as an output (DDB5 set (one)) to serve this function. The OC1A pin is also the output pin for the PWM mode timer function.</p>
7	PB6	OC1B/PWM1B	<p>PB6 – general purpose digital I/O</p> <p>Alternative functions:</p> <p>OC1B – Output Compare Match B output: The PB6 pin can serve as an external output for the Timer/Counter1 Output Compare B. The pin has to be configured as an output (DDB6 set (one)) to serve this function. The OC1B pin is also the output pin for the PWM mode timer function.</p>
8	PB7	OC2/PWM2	<p>PB7 – general purpose digital I/O</p> <p>Alternative functions:</p> <p>OC2 – Output Compare Match output: The PB7 pin can serve as an external output for the Timer/Counter2 Output Compare. The pin has to be configured as an output (DDB7 set “one”) to serve this function. The OC2 pin is also the output pin for the PWM mode timer function.</p> <p>OC1C – Output Compare Match C output: The PB7 pin can serve as an external output for the Timer/Counter1 Output Compare C. The pin has to be configured as an output (DDB7 set (one)) to serve this function. The OC1C pin is also the output pin for the PWM mode timer function.</p>

9	PD0	#INT0/SCL	PD0 – general purpose digital I/O Alternative functions: INT0 – External Interrupt source 0. The PD0 pin can serve as an external interrupt source to the MCU. SCL – Two-wire Serial Interface Clock: When the TWEN bit in TWCR is set (one) to enable the Two-wire Serial Interface, pin PD0 is disconnected from the port and becomes the Serial Clock I/O pin for the Two-wire Serial Interface. In this mode, there is a spike filter on the pin to suppress spikes shorter than 50 ns on the input signal, and the pin is driven by an open drain driver with slew-rate limitation.
10	PD1	#INT1/SDA	PD1 – general purpose digital I/O Alternative functions: INT1 – External Interrupt source 1. The PD1 pin can serve as an external interrupt source to the MCU. SDA – Two-wire Serial Interface Data: When the TWEN bit in TWCR is set (one) to enable the Two-wire Serial Interface, pin PD1 is disconnected from the port and becomes the Serial Data I/O pin for the Two-wire Serial Interface. In this mode, there is a spike filter on the pin to suppress spikes shorter than 50 ns on the input signal, and the pin is driven by an open drain driver with slew-rate limitation.
11	PD2	#INT2/RxD1	PD2 – general purpose digital I/O Alternative functions: INT2 – External Interrupt source 2. The PD2 pin can serve as an External Interrupt source to the MCU. RXD1 – Receive Data (Data input pin for the USART1). When the USART1 receiver is enabled this pin is configured as an input regardless of the value of DDD2. When the USART forces this pin to be an input, the pull-up can still be controlled by the PORTD2 bit.
12	PD3	#INT3/TxD1	PD3 – general purpose digital I/O Alternative functions: INT3 – External Interrupt source 3: The PD3 pin can serve as an external interrupt source to the MCU. TXD1 – Transmit Data (Data output pin for the USART1). When the USART1 Transmitter is enabled, this pin is configured as an output regardless of the value of DDD3.
13	PD4	IC1	PD4 – general purpose digital I/O Alternative functions: XCK1 – USART1 External clock. The Data Direction Register (DDD4) controls whether the clock is output (DDD4 set) or input (DDD4 cleared). The XCK1 pin is active only when the USART1 operates in Synchronous mode. IC1 – Input Capture Pin1: The PD4 pin can act as an input capture pin for Timer/Counter1.
14	PD5		PD5 – general purpose digital I/O
15	PD6	T1	PD6 – general purpose digital I/O Alternative functions: T1 – Timer/Counter1 counter source.
16	PD7	T2	PD7 – general purpose digital I/O Alternative functions: T2 – Timer/Counter2 counter source.
17	LEDACT		The output of the LEDACT diode driving signal (indicating activity of the module in Ethernet network). It can be used to connect an additional diode, e.g. led out externally to the device case.
18	LEDLINK		The output of the LEDLINK diode driving signal (indicating connection to the Ethernet network). It can be used to connect an additional diode, e.g. led out externally to the device case.
19	+5V		Power supply input +5V.
20	GND		Ground.

J2			
Nr	Funkcja	Alt. funkcja	Opis
1	PE7	INT7	PE7 – General purpose digital I/O Alternative functions: INT7 – External Interrupt source 7: The PE7 pin can serve as an external interrupt source. IC3 – Input Capture Pin3: The PE7 pin can act as an input capture pin for Timer/Counter3.
2	PE6	INT6	PE6 – general purpose digital I/O Alternative functions: INT6 – External Interrupt source 6: The PE6 pin can serve as an external interrupt source. T3 – Timer/Counter3 counter source.
3	PE5	INT5	PE5 – general purpose digital I/O Alternative functions: INT5 – External Interrupt source 5: The PE5 pin can serve as an External Interrupt source. OC3C – Output Compare Match C output: The PE5 pin can serve as an External output for the Timer/Counter3 Output Compare C. The pin has to be configured as an output (DDE5 set “one”) to serve this function. The OC3C pin is also the output pin for the PWM mode timer function.
4	PE4	INT4	PE4 – general purpose digital I/O Alternative functions: INT4 – External Interrupt source 4: The PE4 pin can serve as an External Interrupt source. OC3B – Output Compare Match B output: The PE4 pin can serve as an External output for the Timer/Counter3 Output Compare B. The pin has to be configured as an output (DDE4 set (one)) to serve this function. The OC3B pin is also the output pin for the PWM mode timer function.
5	PE3	AC-	PE3 – general purpose digital I/O Alternative functions: AC- – Analog Comparator Negative input. This pin is directly connected to the negative input of the Analog Comparator. OC3A, Output Compare Match A output: The PE3 pin can serve as an External output for the Timer/Counter3 Output Compare A. The pin has to be configured as an output (DDE3 set “one”) to serve this function. The OC3A pin is also the output pin for the PWM mode timer function.
6	PE2	AC+	PE2 – general purpose digital I/O Alternative functions: AC+ – Analog Comparator Positive input. This pin is directly connected to the positive input of the Analog Comparator. XCK0, USART0 External clock. The Data Direction Register (DDE2) controls whether the clock is output (DDE2 set) or input (DDE2 cleared). The XCK0 pin is active only when the USART0 operates in Synchronous mode.
7	PE1	PDO/TPD	PE1 – general purpose digital I/O Alternative functions: PDO – SPI Serial Programming Data Output. During Serial Program Downloading, this pin is used as data output line for the ATmega128. TXD0 – UART0 Transmit pin.

8	PE0	PDI/RxD	PE0 – general purpose digital I/O Alternative functions: PDI – SPI Serial Programming Data Input. During Serial Program Downloading, this pin is used as data input line for the ATmega128. RXD0 – USART0 Receive Pin. Receive Data (Data input pin for the USART0). When the USART0 receiver is enabled this pin is configured as an input regardless of the value of DDRE0. When the USART0 forces this pin to be an input, a logical one in PORTE0 will turn on the internal pull-up.
9	AREF		Analog reference voltage for the A/D converter
10	PF0	ADC0	PF0 – general purpose digital I/O Alternative functions: ADC0 – Analog to Digital Converter, Channel 0.
11	PF1	ADC1	PF1 – general purpose digital I/O Alternative functions: ADC1 – Analog to Digital Converter, Channel 1.
12	PF2	ADC2	PF2 – general purpose digital I/O Alternative functions: ADC2 – Analog to Digital Converter, Channel 2.
13	PF3	ADC3	PF3 – general purpose digital I/O Alternative functions: ADC3 – Analog to Digital Converter, Channel 3.
14	PF4	ADC4/TCK	PF4 – general purpose digital I/O Alternative functions: ADC4 – Analog to Digital Converter, Channel 4. TCK – JTAG Test Clock: JTAG operation is synchronous to TCK. When the JTAG interface is enabled, this pin can not be used as an I/O pin.
15	PF5	ADC5/TMS	PF5 – general purpose digital I/O Alternative functions: ADC5 – Analog to Digital Converter, Channel 5. TMS – JTAG Test Mode Select: This pin is used for navigating through the TAP-controller state machine. When the JTAG interface is enabled, this pin can not be used as an I/O pin.
16	PF6	ADC6/TDO	PF6 – general purpose digital I/O Alternative functions: ADC6 – Analog to Digital Converter, Channel 6. TDO – JTAG Test Data Out: Serial output data from Instruction Register or Data Register. When the JTAG interface is enabled, this pin can not be used as an I/O pin. The TDO pin is tri-stated unless TAP states that shift out data are entered.
17	PF7	ADC7/TDI	PF7 – general purpose digital I/O Alternative functions: ADC7 – Analog to Digital Converter, Channel 7. TDI – JTAG Test Data In: Serial input data to be shifted in to the Instruction Register or Data Register (scan chains). When the JTAG interface is enabled, this pin can not be used as an I/O pin.
18	PG4	TOSC1	PG4 – general purpose digital I/O Alternative functions: TOSC1 - Timer Oscillator pin 1: When the AS0 bit in ASSR is set (one) to enable asynchronous clocking of Timer/Counter0, pin PG4 is disconnected from the port, and becomes the input of the inverting Oscillator amplifier. In this mode, a Crystal Oscillator is connected to this pin, and the pin can not be used as an I/O pin.
19	PG3	TOSC2	PG4 – general purpose digital I/O Alternative functions: TOSC1 - Timer Oscillator pin 2: When the AS0 bit in ASSR is set (one) to enable asynchronous clocking of Timer/Counter0, pin PG3 is disconnected from the port, and becomes the inverting output of the Oscillator amplifier. In this mode, a Crystal Oscillator is connected to this pin, and the pin can not be used as an I/O in.
20	#RESET		Input/output of RESET signal

Detailed description of ports can be found in ATmega128 microcontroller datasheets.

ATmega128 microcontroller

- High-performance RISC architecture, 121 instructions (most single clock cycle execution), 16 MIPS at 16MHz
- 128 KBytes of Flash memory
- 4K Bytes of SRAM memory
- 4K Bytes of EEPROM
- SPI Master/Slave interface
- Four internal timers/counters 8/16bit
- Two UART interfaces (up to 1Mbaud)
- Serial interface compatible with I2C
- In System Programming
- In Circuit Debugging through JTAG interface
- Real Time Clock with 32 kHz oscillator
- 8 channel 10-bit A/D converter
- 6 I/O ports
- 6 PWM outputs
- Extended temperature range, internal and external interrupt sources
- Internal watchdog timer
- More informations at Atmel's site

Ethernet controller RTL8019AS

- One-chip Ethernet controller with ISA bus
- IEEE 802.3 10Mb/s
- Internal 16kB SRAM memory for buffers
- Built-in data prefetch function to improve performance
- Full duplex
- Support diagnostic LEDs

After hardware or software reset, the controller has to be reconfigured. This can be achieved in three ways:

- The configuration is loaded from an external EEPROM memory. In MMnet02 module there is no possibility to mount this memory.
- Emulation of an external EEPROM memory. The Nut/OS system, starting from version 3.9.2, can emulate the EEPROM memory by means of two bus address lines (A13 and A14). This function does not hinder the normal operation of the module. To permit emulation, two resistors (R6 and R13) should be assembled on board (they are not mounted by default).
- A standard method of configuring the RTL8019AS circuit is tying the data inputs from the EEPROM to the VCC through resistor R1. This will ensure proper operation of LED diodes (as LINK and ACT indicators) and sets the controller into the full duplex mode. The remaining parameters (e.g. MAC address) have to be set through software. If the half-duplex mode is required, one of the two other methods should be used.

The module is adapted to operate with the network controller with the use of interrupts. The interrupt signal is applied to input INT5 (PE5) of the microcontroller through R7 resistor (mounted by default).

The state of the Ethernet controller is signaled by two LED diodes: LNK – connection with the network, and ACT – active (transmission/reception).

Memory controller

MMnet01 has simple memory controller, which divides memory space into two areas: RAM memory area and Ethernet controller area. Implementation of memory controller is shown on drawing below:

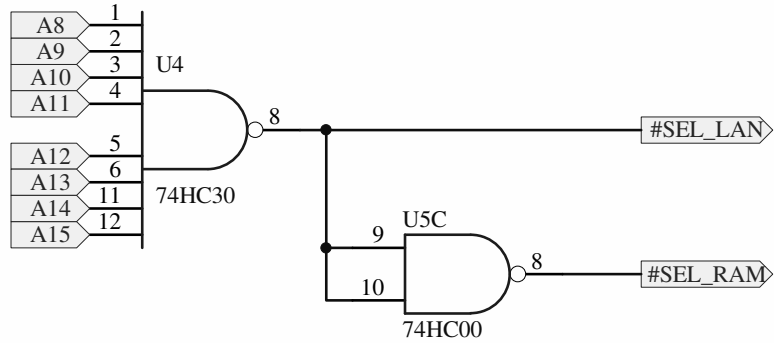

Memory map is shown below:

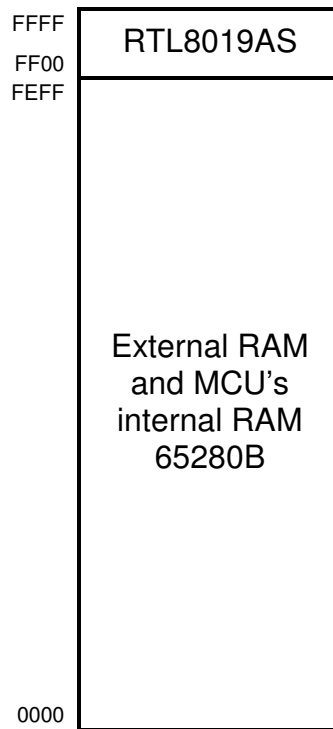

RAM memory

Minimodule is equipped with a 128kB of RAM memory, however this is more than ATmega128 microcontroller is able to address, and therefore memory has been divided into two banks, 64kB each. At any moment only one memory bank is available, and switching banks is done through PB6 pin. Bank switching is possible after mounting R1 resistor (it is not mounted by default, so as a standard only 64kB of memory are available).

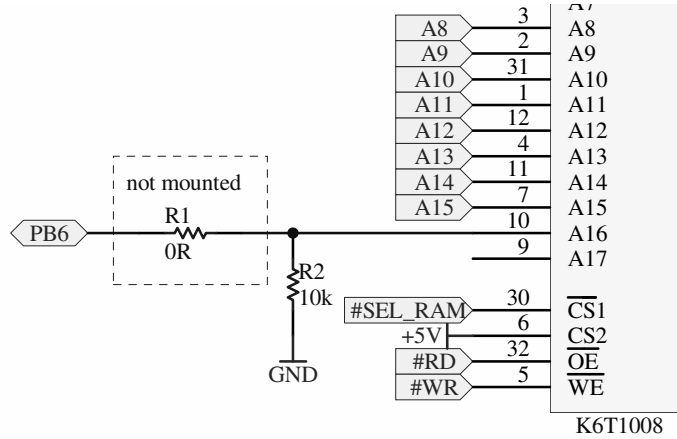

DataFlash memory

The minimodule can be equipped with serial DataFlash memory AT45DB041B (4Mb capacity), this gives 512kB of memory for storing files with WWW pages or collecting measurement files. The memory is connected to a fast SPI bus with 8 MB/s transmission speed.

Memory chip is activated after applying a low logic level to #CS input. The #CS input of memory is connected to port PB5 of the microcontroller. The SPI bus occupies three terminals of the microprocessor: PB1, PB2, PB3. It should be kept in mind that if DataFlash memory is installed, the just outlined port terminals cannot be used externally to the module. Of course the SPI bus can be used for communication with external peripherals, under the condition that they will have circuit selection inputs (CS). The diagram below shows the connection of DataFlash memory inside the module.

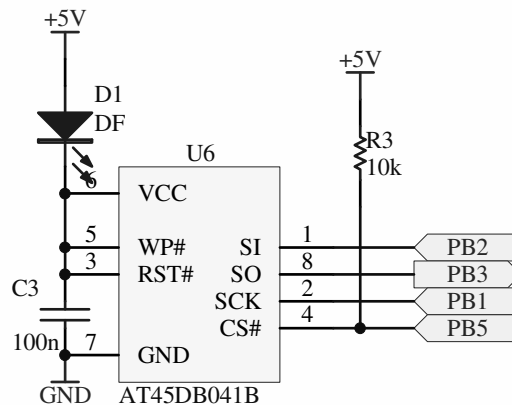

Figure 3 Connection of DataFlash memory inside the module.

A detailed description of DataFlash circuits is on the Atmel Company page: www.atmel.com.

RESET circuit

The MMnet01 has a built-in voltage monitoring circuit constructed around the DS1811 integrated circuit. The circuit generates a RESET signal in case when the supply voltage value is lower than 4.6 V. This takes place when the supply voltage is switched on or off, when the VCC voltage changes its value from 0 to 5 V.

The guard circuit detects also momentary VCC voltage drops. A short duration drop of VCC below 4.6 V causes the generation of a resetting signal of 100 ms duration. This signal is applied directly to the resetting input of the microcontroller and through an inverter to the RTL8019AS circuit. The RESET signal is led out to a module connector and it can be used as the zeroing output resetting external circuits and as the input for resetting the module, e.g. by means of the RESET button. In such a case the RESET button can short the RESET line directly to ground. An implementation of the reset circuit is presented in the diagram below.

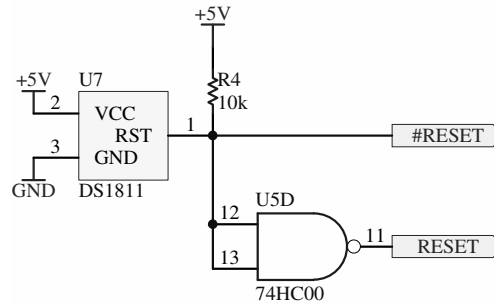

Figure 4 Implementation of the reset circuit in the module.

LED diodes

The minimodule is equipped with four LED diodes which signal the following:

- supply of power
- operation of the Ethernet controller:
 - connection to the network
 - activity (transmission/reception)
- operation of the DataFlash memory (analogously as the HDD diode in PCs).

Diode signals (with exception of DataFlash diode) are led out outside the module which enables doubling the signaling e.g. externally to the device case. An example of a realization of such a solution is shown in the drawing:

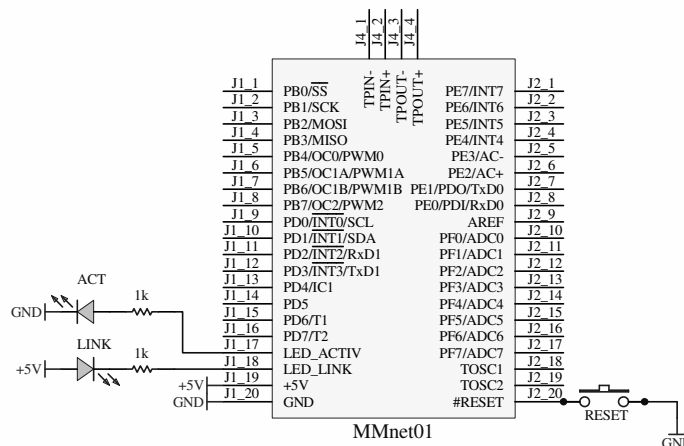

Figure 5 Connection of external signaling diodes and the RESET button.

3 Connection of the module with the external world

Connection to the Ethernet network

MMnet01 module has RJ45 connector integrated with separation transformer and LED diodes. This frees the user from necessity of buying suitable components and mounting them on base board. Led diodes indicates operation of the Ethernet controller: green – connection to the network, orange – activity.

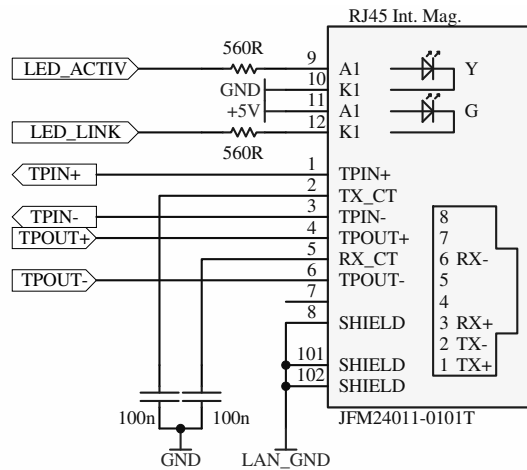

Figure 6 Connection of RJ45 jack inside module.

The module can be also bought without mounted RJ45 connector. In this case Ethernet signals are led out from module through J4 connector. This option makes possible to place separation transformer on the base board and use Power-Over-Ethernet technology or power device through Ethernet cable.

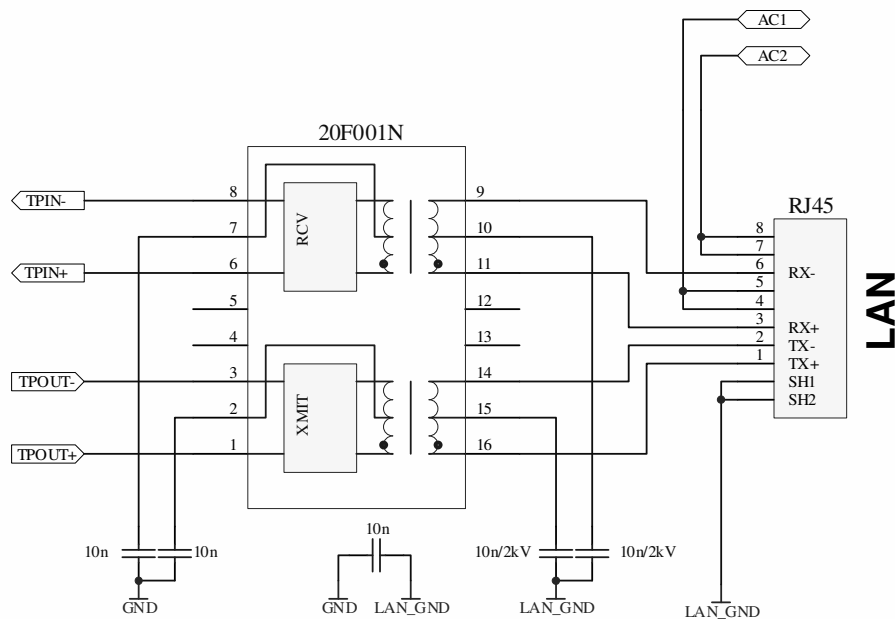

Figure 7 Connection to the Ethernet using a transformer.

RS-232 interface

The ATmega128 microcontroller has two USART ports which can be used to connect the minimodule with a PC computer or other equipment equipped with a RS-232 port. Such a connection requires a level converter based on a MAX232 or similar IC, connected to the TxD and RxD lines.

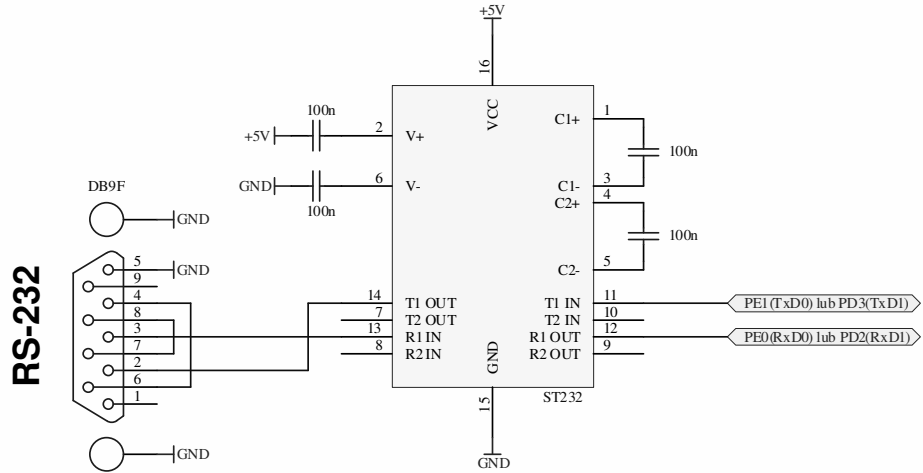

Figure 8 Connection of the RS-232 to the MMnet01.

RS-485 interface

The RS-485 interface facilitates long-distance transmission in a difficult environment. An implementation of this interface is as simple as that of RS-232 and requires only a line driver, e.g. MAX485. The feature discerning this interface from RS-232 is the necessity to control the direction of action of the driver (transmission/reception). This control is effected through the program, using any I/O pin of the microcontroller. The 560R resistors visible in the diagram polarize initially the inputs, increasing the immunity to interference. The 120R resistor connected by means of a shorting strap is used to match the interface to the line impedance.

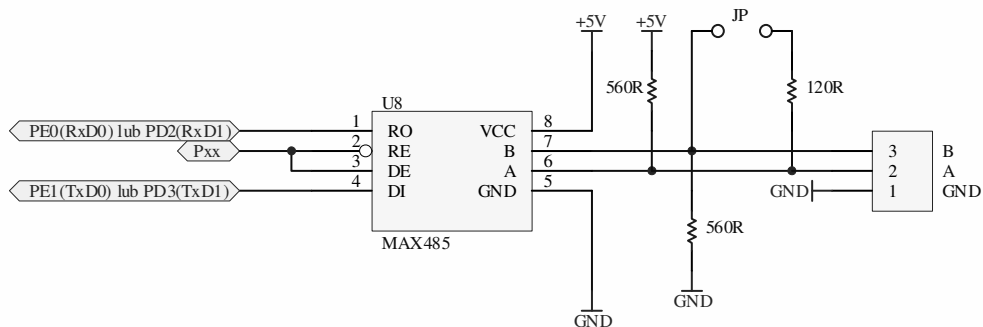

Figure 9 Connection of the RS-485 port to the MMnet01.

USB interface

The current standard in connecting with a PC, the USB interface, permits quick transfers and taking the power supply from the computer. Thanks to the existence of circuits converting the USB interface to RS-232, its implementation in own equipment is very simple and cheap. The drawing below presents a way of equipping the MMnet01 module with an USB interface, using the MMusb232 module. After installing VCP drivers, such an interface is seen in the system as a virtual COM port, thus its software on the PC should surely provide no problems.

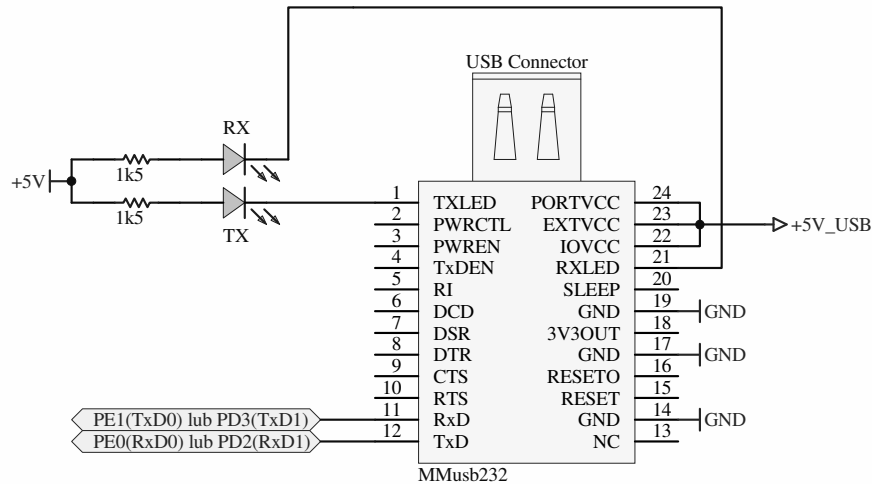
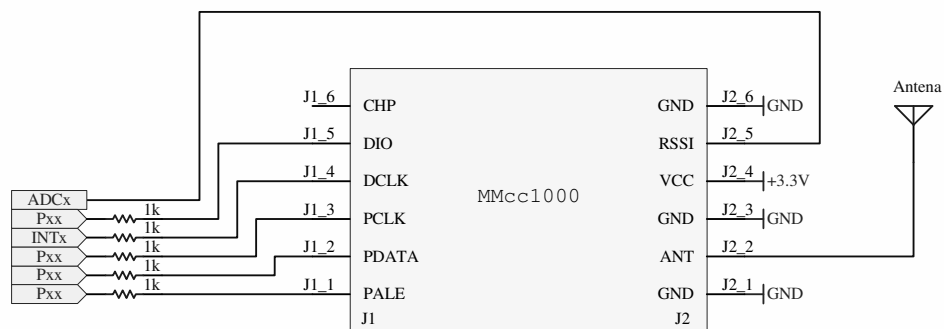

Figure 10 Connection of the USB port to the MMnet01.

Additional information on the MMusb232 module can be found on the web page:
http://www.propox.com/products/t_93.html?lang=en

Radio link

Fitting the system with the possibility of communicating via a wireless path provides a possibility of easy control and collection of measurement data from system elements dispersed in the object, without the need to install any cabling. Thanks to the existence of integrated transceivers the construction of such links is relatively simple. The figure presents a way of connecting an MMnet01 module with a radio minimodule MMcc1000. To execute such a connection, five I/O microcontroller lines are needed, including one breakpoint input. An optional connection of the RSSI output with the input of the A/D converter permits the measurement of the strength of the received signal.



Additional information on the MMcc1000 module can be found on the page:
http://www.propox.com/products/t_92.html?lang=en

LCD display

MMnet01 module does not have external system bus, so LCD display can be connected only to microcontroller's ports. Such a solution is shown in the figure below.

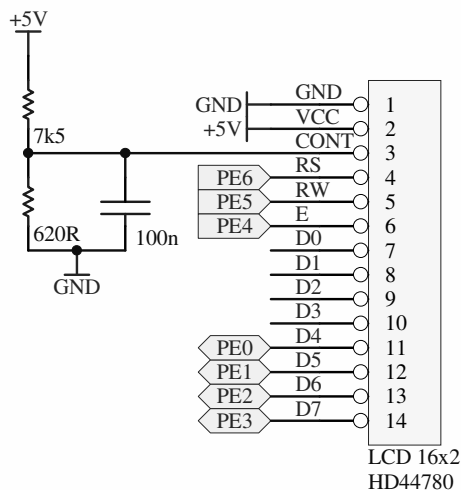

Figure 11 Connection of the LCD display to microcontroller ports.

RW input can be permanently connected to ground, which reduce necessary pin count to six.

4 Programming the module

The ATmega128 microcontroller has 128kB of Flash memory programmable in the system for the program code and 4kB of EEPROM memory for user's data. Programming of these memories can be effected in two ways: by means of an ISP interface or through JTAG. Both interfaces have a standard of used connectors and a standard of arranging signals in the connector.

ISP connector

The programmer in ISP standard communicates with the microcontroller through a three-wire SPI interface (plus the RESET signal and power supply). The interface uses the I/O terminals of the microcontroller (PE0, PE1 and PB1) which, after the programming, can fulfill ordinary functions. When connecting peripherals to these terminals it should be remembered that the programmer should have the possibility to force appropriate logic levels on them. The figures below present the method of connecting the ISP connector to the module. Figure 13 shows the use of an analog multiplexer 4053 to separate the programmer from the peripherals connected to microcontroller ports.

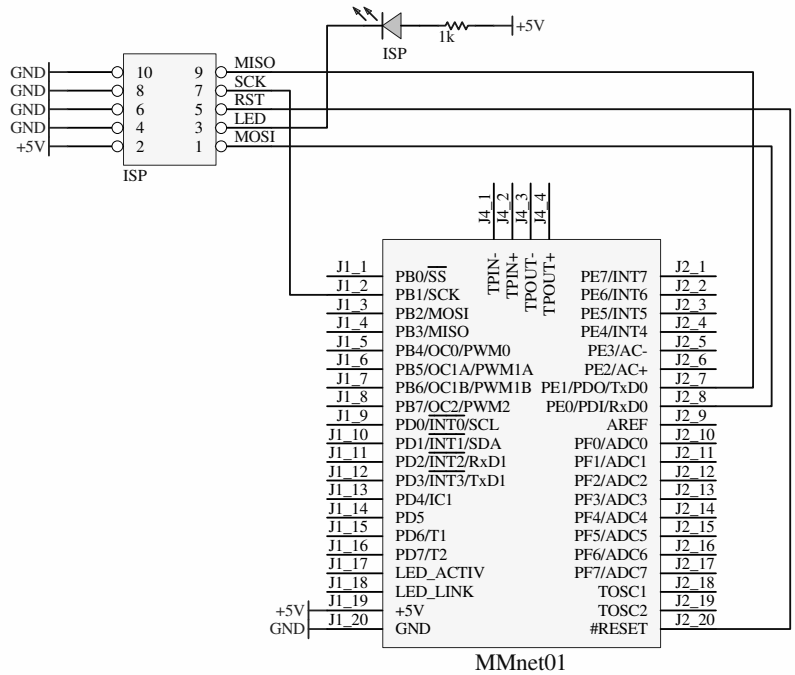

Figure 12 Connecting the MMnet01 module with an ISP connector.

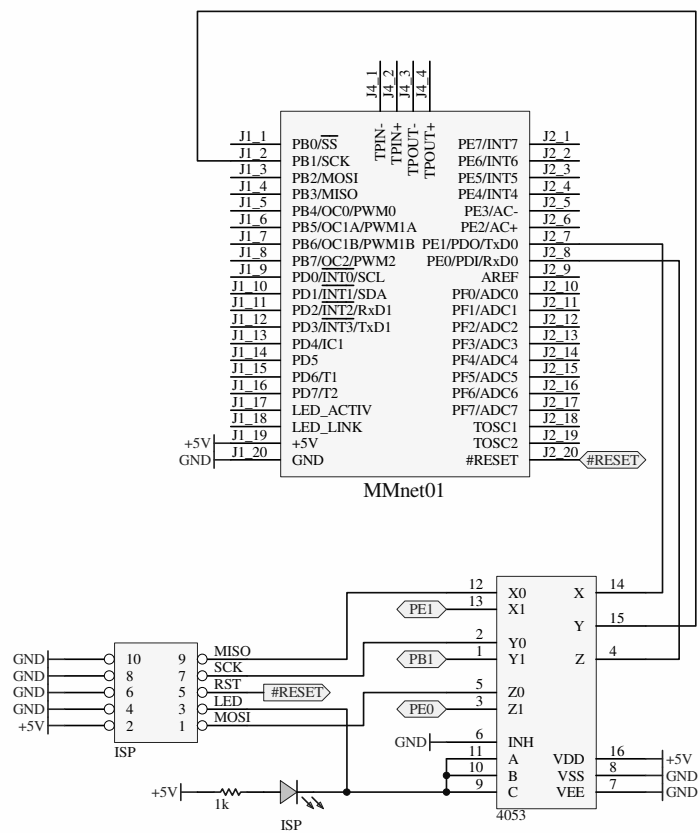

Figure 13 Connection of the MMnet01 module with an ISP connector using a multiplexer.

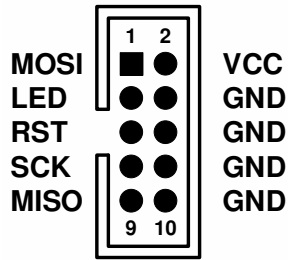

Figure 14 ISP connector.

PIN DESCRIPTION

- MOSI** Commands and data from programmer to target
- LED** Multiplexer and LED diode driving signal
- RST** RESET signal
- SCK** Serial Clock, Controlled by programmer
- MISO** Data from target AVR to programmer
- VCC** Supply voltage to the programmer
- GND** Ground

Caution: The SPI interface used for programming the processor is not the same interface which is available to the user for communication with peripherals and it uses other outputs.

Programmers which can be used to program the MMnet01 can be found on the following pages:

- ISPCable I: http://www.propox.com/products/t_77.html?lang=en
- ISPCable II: http://www.propox.com/products/t_78.html?lang=en

JTAG connector

JTAG is a four-lead interface permitting the takeover of control over the processor's core and its internal peripherals. The possibilities offered by this interface are, among others: step operation, full-speed operation, equipment and program pitfalls, inspection and modification of contents of registers and data memories. Apart from this, functions are available offered by ISP programmers: programming and readout of Flash, EEPROM, fuse memories and lock bites. The method of connecting the JTAG connector to the minimodule is shown in the drawing:

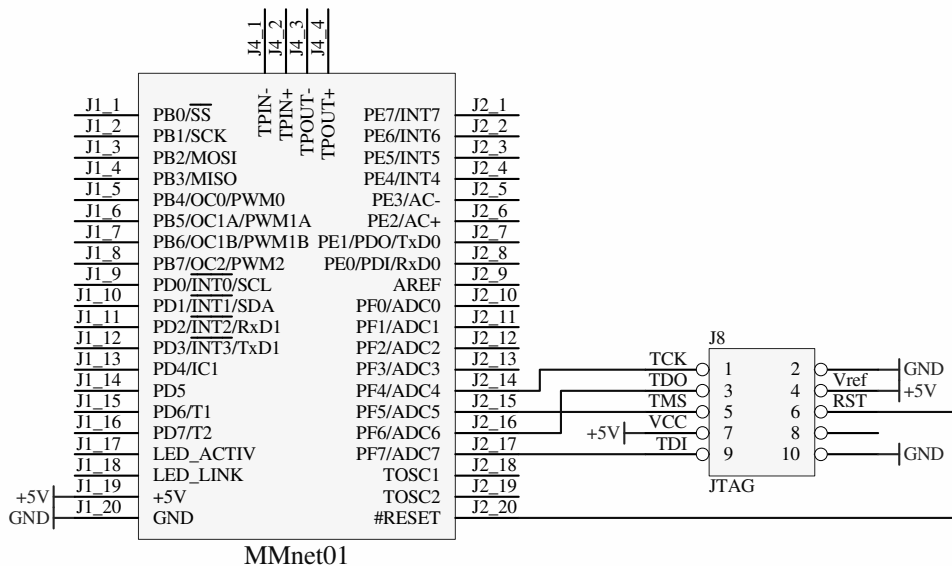

Figure 15 Connection of the MMnet01 module with the JTAG connector.

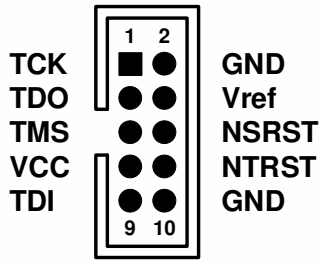

Figure 16 JTAG connector.

PIN DESCRIPTION	
TCK	Test Clock, clock signal from emulator to target
TDO	Test Data Output, data signal from target to emul.
TMS	Test Mode Select, mode select signal from
VCC	Supply voltage to the emulator
TDI	Test Data Input, data signal from emul. to target
Vref	Target voltage sense
RST	RESET signal
GND	Ground

If the JTAG interface is connected into the fuse bits of the microcontroller, then terminals PF4...PF7 (ADC4...ADC7) can serve only as an interface and cannot operate as I/O terminals or analogue inputs.

The programmer/emulator JTAG can be found on the page:

- JTAGCable I : http://www.propox.com/products/t_99.html?lang=en

5 An application example

The diagram below shows the MMnet01 module in a simple application, controlling relays through the Ethernet network (e.g. surfing the WWW). The diagram does not include the supply of power.

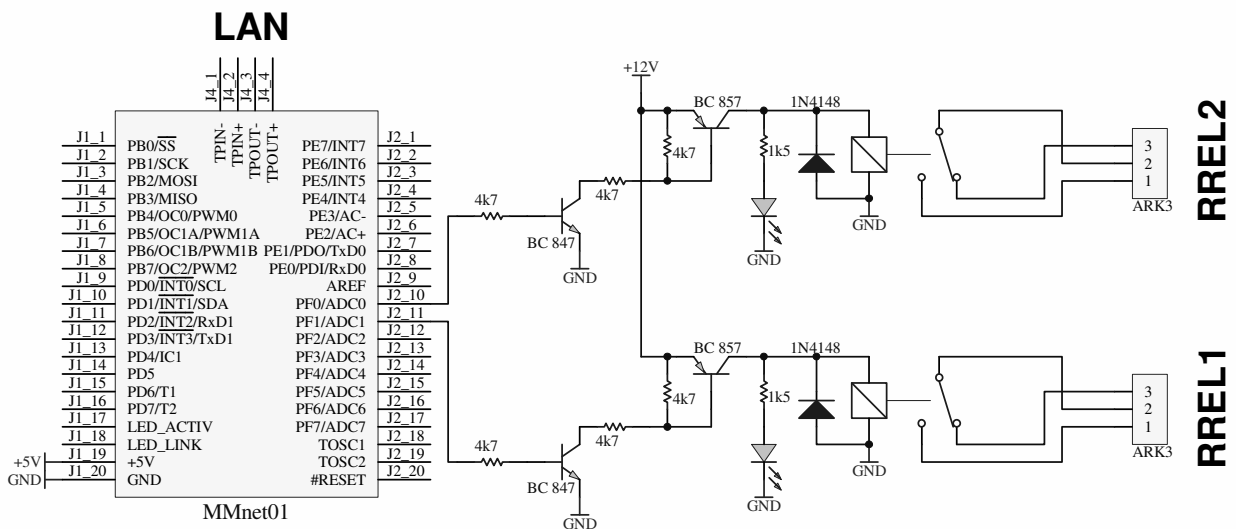

Figure 17 MMnet01 in a simple application controlling relays through the Ethernet network.

6 Evaluation Board

In order to facilitate the design of equipment using the minimodule, an evaluation board has been prepared (EVBnet02). It includes the following basic elements:

- Power supply
- RS232 port
- USB port (with use of MMusb232 minimodule)
- ISP connector
- JTAG connector
- 2x16 chars LCD display
- 8 LED diodes
- 4 push-buttons
- 2 potentiometers
- Prototype design area



7 Specifications

Microcontroller	ATmega128 16MHz
Ethernet controller	RTL8019AS IEEE 802.3 10Mb/s
Program memory	128kB
Data memory	64kB or 128kB
EEPROM memory	8kB
DataFlash memory	up to 8MB
No. of digital I/O	up to 32
No. of analog inputs	up to 8
Power	5V 5%
Power consumption	110mA max
Dimensions	56x30.5mm
Weight	about 100g
Operating temperature range	0 – 70°C
Humidity	5 – 95%
Connectors	double 1x20 headers

8 Technical assistance

In order to obtain technical assistance please contact support@propox.com . In the request please include the following information:

- number of the module version (e.g. REV 2)
- setting of resistors
- a detailed description of the problem

9 Guarantee

The MMnet01 minimodule is covered by a six-month guarantee. All faults and defects not caused by the user will be removed at the Producer's cost. Transportation costs are borne by the buyer.

The Producer takes no responsibility for any damage and defects caused in the course of using the MMnet-02 module.

10 Assembly drawings

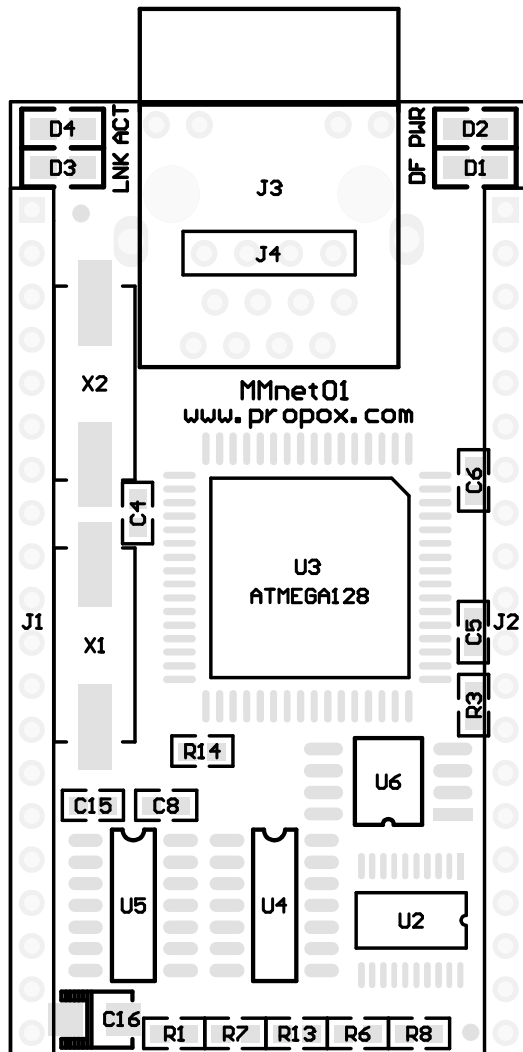

Figure 18 Assembly drawing – top layer.

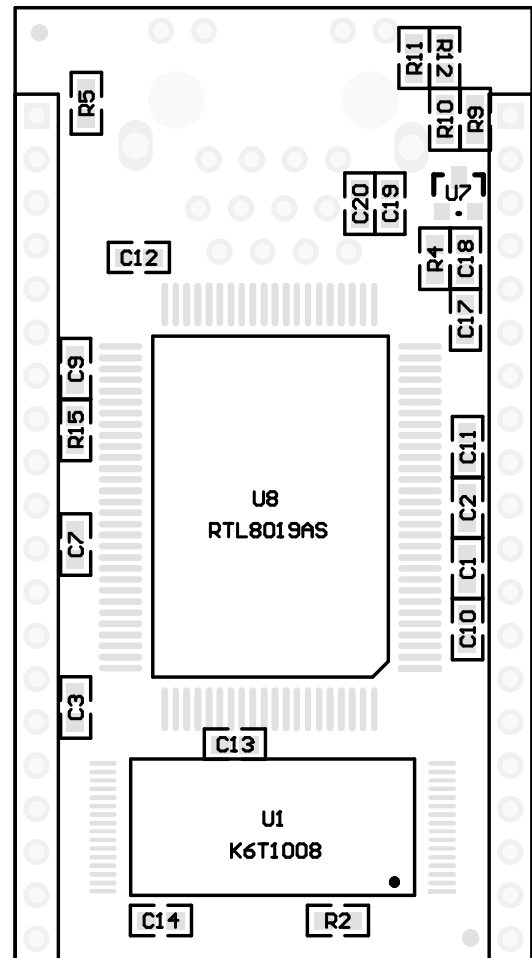

Figure 19 Assembly drawing – bottom layer.

11 Dimensions

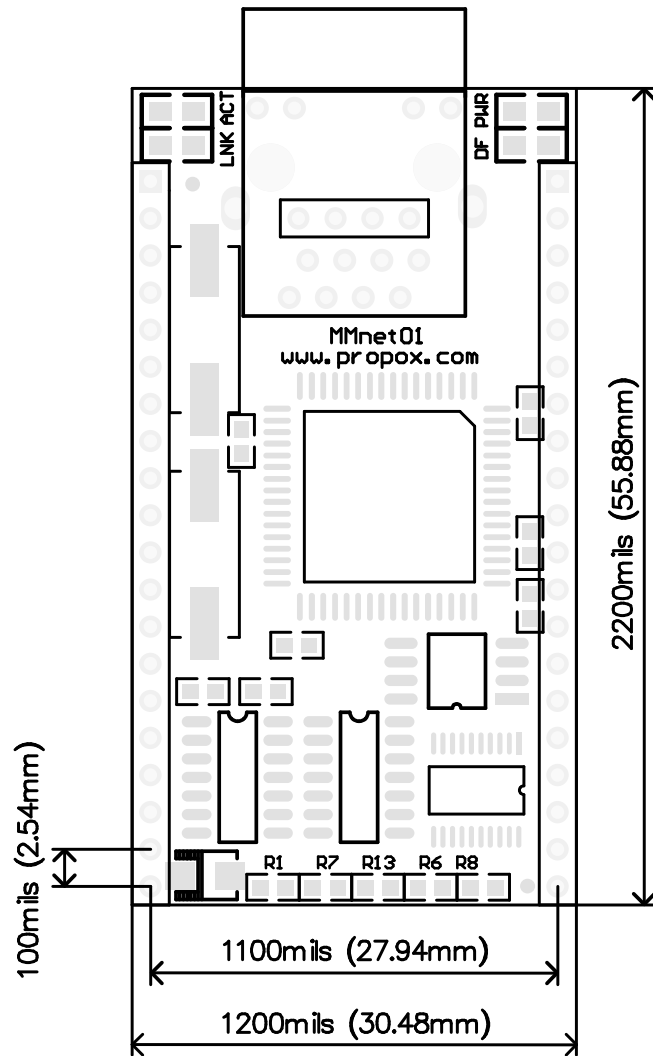
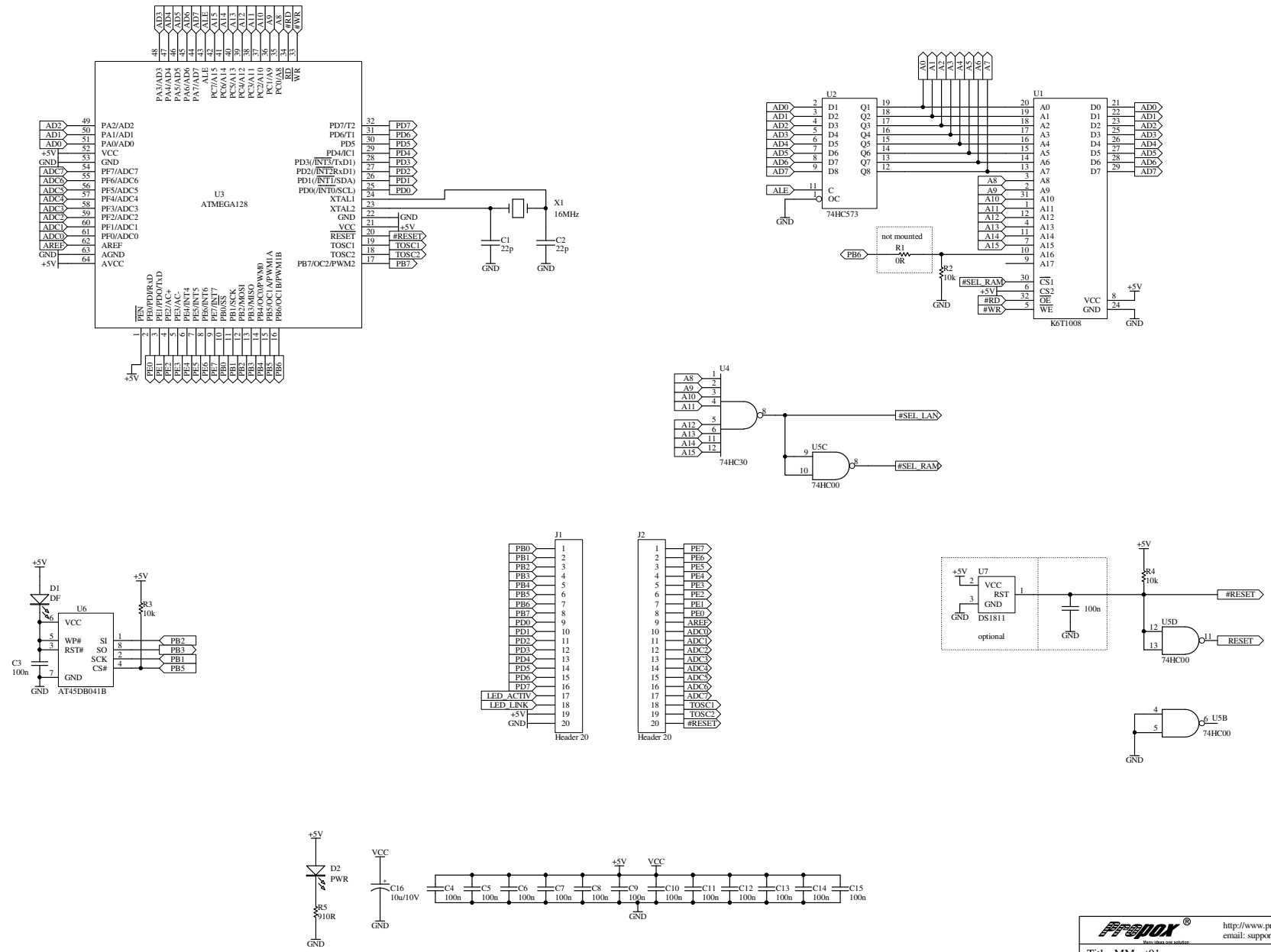

Figure 20 Dimensions – top view.

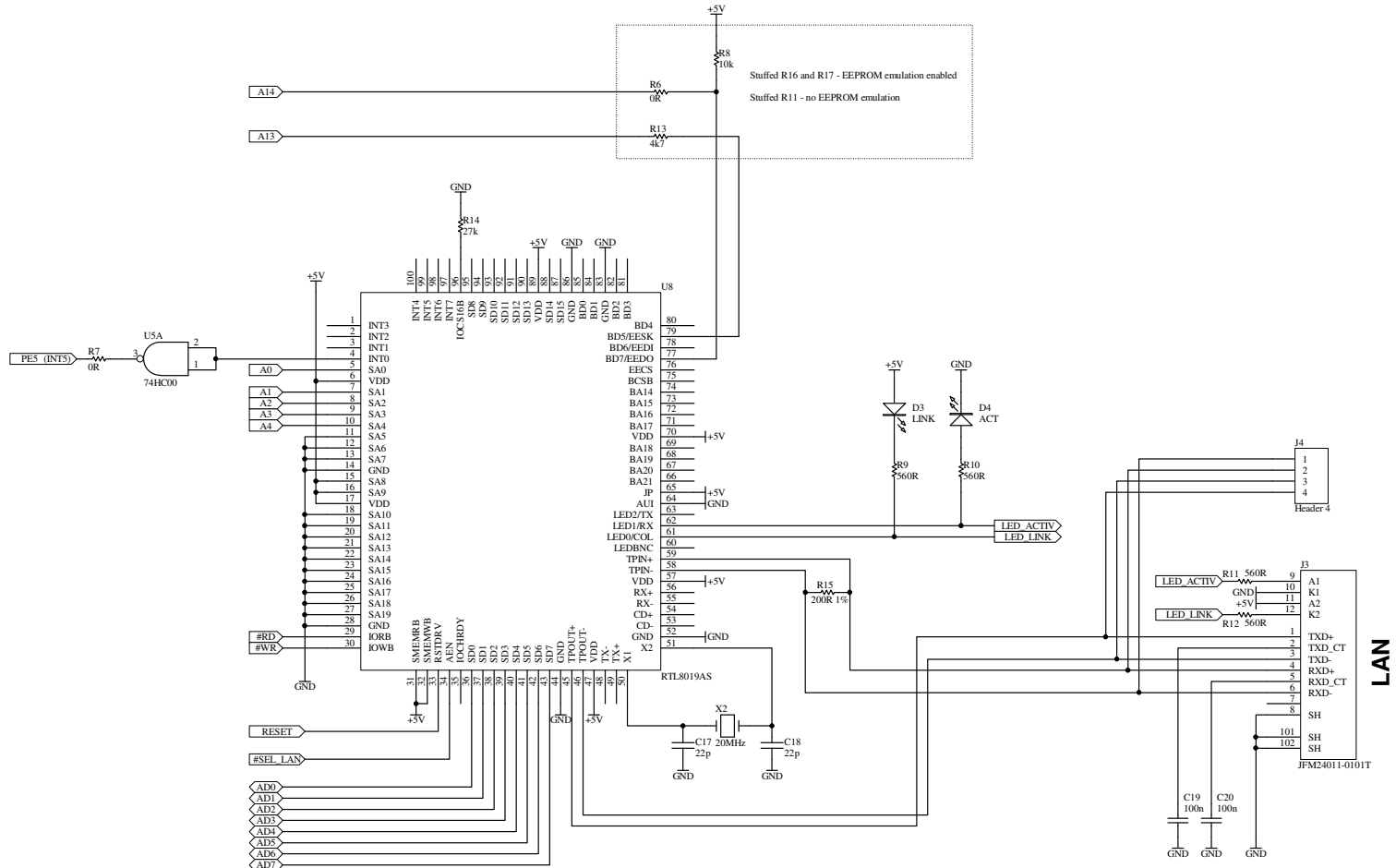



Figure 21 Dimensions – side view.

12 Schematics



PROPPOX <small>www.propox.com</small>		http://www.propox.com email: support@propox.com	
Title: MMnet01			
Size:	File:	Rev:	
Date: 15-03-2005	Sheet 1 of 2	1.1	



<http://www.propox.com>
 email: support@propox.com

Title: MMnet01		
Size:	File:	Rev:
Date: 15-03-2005	Sheet 2 of 2	1.1