

| | | |
|------------|---------|------|
| PT-LB20NTE | 2000 lm | XGA |
| PT-LB20E | 2000 lm | XGA |
| PT-LB20SE | 2000 lm | SVGA |
| PT-LB20VE | 1600 lm | XGA |



**Daylight
View**

Presentations in Light



Daylight View technology

- Image performance rivalling 3,000-lumen projectors^{*1*}
- Vivid colours in a bright room
- Auto operation with ambient light sensor

Quick operation

- 2-second speed start
- One-touch auto setup with digital keystone correction
- Direct power off

Easy wireless projection (PT-LB20NTE)

- Wireless PC motion/sound streaming^{*3}
- High-speed data transfer
- Flexible 16-window index style
- Simple, user-friendly settings

Portability

- Notebook-size compact body
- Ultra-lightweight: 2.1 kg (4.6 lbs)^{*4}

^{*1} In comparison with our product

^{*2} The PT-LB20VE rivals 2,400-lumen projectors in image performance.

^{*3} Supports ASF, WMV, AVI, MPEG4 and MPEG1/2 movie formats.

^{*4} PT-LB20NTE: 2.2 kg (4.9 lbs)

Many people want to use special colours and designs in their presentations, but the colours always change when they're projected onto the screen in a lighted room. So they just use plain colours. As a result, the presentation is visually boring and looks just like their competitor's.

Panasonic solves this problem with our PT-LB20 Series projectors featuring innovative Daylight View technology. These projectors greatly improve image performance in brightly lit places. In fact, the 2,000-lumen brightness of the PT-LB20 Series achieves a level of image performance that equals many 3,000-lumen projectors.*1*2

Starting with the wireless motion and sound streaming capability of the PT-LB20NTE, the Panasonic PT-LB20 Series projectors pack an array of powerful functions into a compact, lightweight body. Select the one that best matches your presentation needs.

Image Performance Rivaling 3,000-Lumen Projectors

Daylight View technology significantly improves image performance. Our new 2,000-lumen projectors have attained a level of image performance that equals or exceeds that of our previous 3,000-lumen models in brightly lit environments.*3

The Panasonic PT-LB20 Series with Daylight View



Conventional 2,000-lumen projectors

Colours turn whitish



Vivid Colours in a Bright Room

Panasonic designed and adjusted its projector image display based on use in a well-lit room in developing Daylight View technology. This technology greatly improves colour perception in bright rooms. Pale colours are divided into six basic colour components (red, green, blue, yellow, cyan and magenta) for more precise control. Daylight View achieves a superb level of image performance that produces less of a difference between PC display images and projected images.

Auto Operation with Ambient Light Sensor

The top panel of the unit is equipped with an ambient light sensor (ALS). The ALS detects changes in the ambient light intensity and optimises colour compensation in four steps according to the environment. The Daylight View mode also provides white balance adjustment settings for both fluorescent and incandescent lamps to match the room lighting.

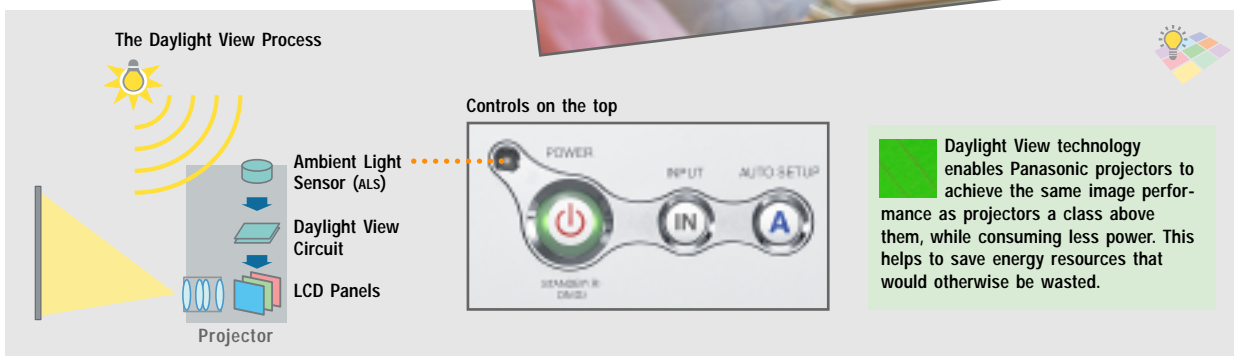

*1 In comparison with our product, under room lighting conditions of 400 lux, when projecting an 80-inch image (measured diagonally)

*2 The PT-LB20VE with 1,600 lumens of brightness achieves a level of image performance comparable to projectors with 2,400 lumens of brightness.

*3 The Daylight View effect may vary depending on screen size, screen gain, and surrounding brightness.

Easy Wireless Projection (PT-LB20NTE)

Set yourself free. 



PC Movies

High-Speed Data Transfer

The IEEE 802.11b/g-compliant wireless LAN function enables high-speed data transfer.*5 In Live mode and Multi Live mode, the content of the PC screen is projected with the same smooth image motion as you get with a wired connection. The motion also flows naturally in PowerPoint animations. Plus, the function combines with an original environment-adaptive dispersion

Sound

Wireless PC Motion/Sound Streaming

Wireless Manager Mobile Edition 2, an original application software for wireless presentations, is supplied. This software makes it easy to use a variety of wireless functions. In Motion Streaming mode, moving-image files*4 can be sent completely wireless, together with audio, from the hard disk of a PC. There's no need to connect an external video source. Just set up the PC somewhere in the room and immediately start into an effective presentation using both moving images and sound.



Movie Files

algorithm to make moving pictures in Motion Streaming mode extremely smooth too.

Simple, User-Friendly Settings



Wireless Manager Control Panel

We have simplified the process for installing Wireless Manager ME 2 and setting up a PC for a wireless presentation. Just insert the CD-ROM into the PC, and many of the settings are made automatically. When the presentation is finished, Wireless Manager restores all PC settings to their original state, so the PC is ready to reconnect to your company LAN. When connection is not possible, a detailed error message is displayed to help solve the problem quickly.

Other Wireless Features

- Projector control/status monitoring capability via an Internet browser
- Automatic connection to registered projector units
- Follows the Advanced Encryption Standard (AES), which has been adopted as an official U.S. Government standard
- Wireless shutter function
- One-shot mode
- PowerPoint page up/down operation using the supplied remote control

Flexible 16-Window Index Style

In Multi Live mode, a single projector unit can receive data from multiple PCs and display their images simultaneously on its multi-window screen. The projection style can be selected from Four Window, Index and Extended Index. It is also possible to send images from a single PC to multiple projector units.*6

Extended Index Style: 16 Thumbnails
This style projects images from up to sixteen PCs as small windows. Using the projector's remote control, you can select any one of the index windows and display it on the main window or on a full screen.



Index Style: Four Thumbnails
This style projects images from up to four PCs as small windows along the bottom of the screen.



Four-Window Style
The operation is controlled using Wireless Manager ME 2.



By building the wireless function into the projector, we were able to eliminate the need for a wireless card and keep the appearance of the unit slimmer and neater.



*4 Supports ASF, WMV, AVI, MPEG4 and MPEG1/2 movie formats. Copyright protection measures prevent wireless projection of DVD sources.

*5 The maximum data transfer speed is 30 frames per second (fps). This speed differs depending on the PC's performance and environment.

*6 Up to eight units.

Quick Operation

2-Second Speed Start

Speed Start slashes the time it takes to get your presentation under way. The image appears within two seconds after you press the power button. Behind this breakthrough is Panasonic's high-precision lamp and lamp power supply—an advantage made possible by our advanced production technology.

One-Touch Auto Setup with Digital Keystone Correction

This function assures quick and easy setup. The projector handles the basic image adjustments, from phasing to vertical and horizontal position. The built-in gravity sensor detects the projector's angle relative to the floor and corrects for vertical keystone distortion accordingly.

Direct Power Off

When the presentation is completed, Direct Power Off lets you disconnect the power cable and move the projector right away*⁷ because the cooling fan keeps operating until the lamp is cooled.

Portability

Notebook-Size Compact Body

PT-LB20 models are 297 mm wide by 210 mm deep—about the size of an A4 sheet of paper—and only 65 mm high. Each slips easily into a bag or briefcase. The

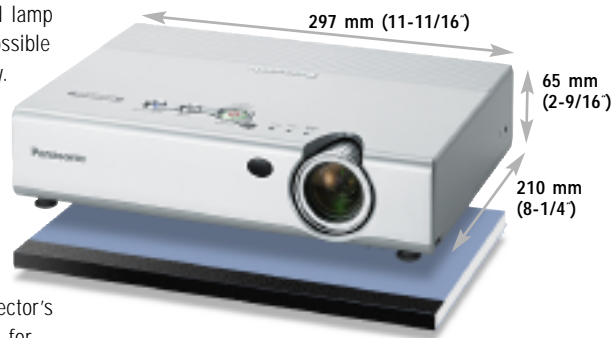

compact size makes these models highly mobile and minimises the space required for presentations or storage.

Ultra-Lightweight: 2.1 kg (4.6 lb)

At only 2.1 kg*⁸, PT-LB20 models won't weigh you down—even when you're toting along a notebook PC as well. Convenient size and weight are just two reasons why the PT-LB20 series is the logical choice for mobile presentations.

More Valuable Features

- Short-throw zoom lens
- Anti-theft features: User password, control panel lock and text superimposing
- Projector AI
- Index Window
- Auto power off
- Two RGB inputs
- RGB 2 IN can be switched to RGB 1 OUT for loop-through monitoring
- Auto Search
- Automatic input signal detector
- HDTV compatibility
- Full compatibility with sRGB colour space for accurate colour reproduction (in natural mode)
- Picture mode selection (standard/dynamic/natural)
- Blackboard mode allows you to project images onto an ordinary classroom or conference room blackboard
- 3x digital zoom
- Freeze
- Shutter function for image/sound muting
- Selectable 17-language on-screen menu (English, French, German, Spanish, Italian, Korean, Russian, Chinese, Japanese, Swedish, Norwegian, Danish, Portuguese, Polish, Hungarian, Czech, Thai)
- Discrete S-Video and video inputs allow connection of two DVD/video sources at a time
- Ceiling mountable (option)
- Lamp power high/low selection
- Temperature warning indication
- Lamp replacement warning indication

PT-LB20 Series Feature Comparison

| | PT-LB20NTE | PT-LB20E | PT-LB20SE | PT-LB20VE |
|---|--------------|--------------|--------------|--------------|
| Brightness | 2,000 lumens | 2,000 lumens | 2,000 lumens | 1,600 lumens |
| Native resolution (max.) | XGA (UXGA) | XGA (UXGA) | SVGA (UXGA) | XGA (UXGA) |
| Daylight View | Yes | Yes | Yes | Yes |
| Throw distance | 1.1–10.7 m | 1.1–10.7 m | 1.1–11.0 m | 1.4–12.7 m |
| 2-Second speed start | Yes | Yes | Yes | Yes |
| One-touch auto setup | Yes | Yes | Yes | Yes |
| Direct power off | Yes | Yes | Yes | Yes |
| Blackboard mode | Yes | Yes | Yes | No |
| Notebook-size compact body (297 x 65 x 210 mm) | Yes | Yes | Yes | Yes |
| Weight | 2.2 kg | 2.1 kg | 2.1 kg | 2.1 kg |
| Wireless presentation capability | Yes | No | No | No |

Ecology-Conscious Design

Panasonic works from every angle to minimise environmental impact in the product design, production and delivery processes, and in the performance of the product itself over its life cycle. The PT-LB20 Series reflects the following ecological considerations.

- Lead-free solder is used to mount components to the printed circuit boards.
- No halogenated flame retardants are used in the cabinet.
- No styrofoam is used in the packing materials.
- Lead-free glass is used for the lens.
- The packing case and operating manual are made from recycled paper.



Optional ceiling mount bracket: ET-PKB30

*⁷ The projector cannot be placed into a bag until the cooling fan stops operating.
*⁸ PT-LB20NTE: 2.2 kg/4.9 lbs



Introducing Innovative Daylight View Projectors



**Daylight
View**



Wireless
Motion/Sound
Streaming

PT-LB20NTE
WIRELESS XGA Projector

2000 lm



Set yourself free. 

Vivid Presentations Anywhere

PT-LB20E
MOBILE XGA Projector

2000 lm



PT-LB20SE
MOBILE SVGA Projector

2000 lm



PT-LB20VE
MOBILE XGA Projector

1600 lm



Specifications

| | |
|----------------------------------|--|
| Power supply | 100–240 V AC, 50/60 Hz |
| Power consumption | 220 W (Approx. 4 W in standby mode with fan stopped) |
| Amps | 2.5 A–1.3 A |
| LCD panel | 4:3 aspect ratio, micro lens array |
| Panel size | |
| PT-LB20NTE/LB20E/LB20SE | 0.7' (17.78 mm) diagonal |
| PT-LB20VE | 0.6' (15.24 mm) diagonal |
| Display method | Transparent LCD panel (x 3, R/G/B) |
| Drive method | Active matrix |
| Pixels | |
| PT-LB20NTE/LB20E/LB20VE | 786,432 (1,024 x 768) x 3, total of 2,359,296 pixels |
| PT-LB20SE | 480,000 (800 x 600) x 3, total of 1,440,000 pixels |
| Pixel configuration | Stripe |
| Lens | Manual zoom (1:1–1:1.2), manual focus |
| PT-LB20NTE/LB20E/LB20VE | F 1.7–1.9, f 21.5–25.8 mm |
| PT-LB20SE | F 1.8–2.1, f 22.0–26.2 mm |
| Lamp | 155 W UHM™ lamp |
| Colours | Full colour (16,777,216 colours) |
| Brightness | |
| PT-LB20NTE/LB20E/LB20SE | 2000 lumens |
| PT-LB20VE | 1600 lumens |
| Uniformity | 90% |
| Contrast | 400:1** (full on/full off) |
| Scanning frequency | |
| RGB | Horizontal: 15–91 kHz, Vertical: 50–85 Hz |
| YPbPr | 480i (525i): fh 15.25 kHz; fv 60 Hz 576i (625i): fh 15.63 kHz; fv 50 Hz 480p (525p): fh 31.5 kHz; fv 60 Hz 576p (625p): fh 31.25 kHz; fv 50 Hz 720p (750p): fh 45 kHz; fv 60 Hz 1080i (1125i): fh 33.75 kHz; fv 60 Hz 1080i (1125i): fh 28.125 kHz; fv 50 Hz |
| S-Video/Video | NTSC, NTSC4.43, PAL-M, PAL60: fh 15.75 kHz; fv 60 Hz PAL, SECAM, PAL-N: fh 15.63 kHz; fv 50 Hz |
| Projection size | 838–7,620 mm/33–300 inches diagonally |
| Throw distance | |
| PT-LB20NTE/LB20E | 1.1 m–10.7 m (3.7–35.1') |
| PT-LB20SE | 1.1 m–11.0 m (3.7–36.1') |
| PT-LB20VE | 1.4 m–12.7 m (4.7–41.8') |
| Optical axis shift | |
| PT-LB20NTE/LB20E/LB20SE | 6:1 (fixed) |
| PT-LB20VE | 12:1 (fixed) |
| Keystone correction range | Vertical: approx. ±30° |
| On-screen menu | 17 languages: English, French, German, Spanish, Italian, Korean, Russian, Chinese, Japanese, Swedish, Norwegian, Danish, Portuguese, Polish, Hungarian, Czech, Thai |
| Installation | Front/rear ceiling/desk (menu selection) |
| Built-in speakers | 1.0 W (monaural) output power |
| Terminals | |
| RGB1 IN | D-sub HD 15-pin x 1 |
| RGB signal | R, G, B: 0.7 Vp-p, 75 ohms, Sync on green: 1.0 Vp-p, 75 ohms HD/SYNC, VD: TTL (positive/negative polarity compatible) |
| YPbPr signal | Y: 1.0 Vp-p (including sync signal), 75 ohms; Pb, Pr: 0.7 Vp-p, 75 ohms |
| RGB2 IN/RGB1 OUT | D-sub HD 15-pin x 1 (input/output selectable using on-screen menu) |
| RGB signal | R, G, B: 0.7 Vp-p, 75 ohms, Sync on green: 1.0 Vp-p, 75 ohms HD/SYNC, VD: TTL (positive/negative polarity compatible) |

| | |
|----------------------------------|---|
| YPbPr signal | Y: 1.0 Vp-p (including sync signal), 75 ohms; Pb, Pr: 0.7 Vp-p, 75 ohms |
| VIDEO IN | RCA pin x 1, 1.0 Vp-p, 75 ohms |
| S-VIDEO IN | Mini DIN 4-pin x 1 |
| AUDIO IN | Y: 1.0 Vp-p, C: 0.286 Vp-p, 75 ohms RCA (L, R) x 1, 0.5 Vrms (for RGB/VIDEO/S-VIDEO) |
| SERIAL | Mini DIN 8-pin x 1 (RS-232C) |
| Power cord length | 2 m (6.7') |
| Cabinet material | Moulded material (ABS/PC) |
| Dimensions (W x H x D) | 297 x 65 x 210 mm (11-11/16" x 2-9/16" x 8-1/4")** |
| Weight | PT-LB20NTE: 2.2 kg (4.9 lbs.) PT-LB20E/LB20VE/LB20SE: 2.1 kg (4.6 lbs.) |
| Operating environment | |
| Temperature | 0°–40°C (32°–104°F) |
| Humidity | 20%–80% (no condensation) |
| Remote Control Unit | |
| Power supply | 3 V DC (button battery x 1) |
| Operation range** | Approx. 7 m (23 feet) when operated from directly in front of the signal receptor |
| Dimensions (W x H x D) | 40 x 86 x 6.5 mm (1-9/16" x 3-3/8" x 1/4") |
| Weight | 18 g (0.6 oz.) (including a battery) |
| Wireless LAN (PT-LB20NTE) | |
| Standard | IEEE802.11b/g |
| Modulation | |
| IEEE802.11b | Direct sequence spread spectrum (ds-ss) system |
| IEEE802.11g | Orthogonal frequency division multiplex (OFDM) system |
| Transmission system | |
| IEEE802.11b | CCK (11/5.5 Mbps), DQPSK (2 Mbps), DBPSK (1 Mbps) |
| IEEE802.11g | 64-QAM (54/48 Mbps), 16-QAM (36/24 Mbps), QPSK (18/12 Mbps), DPSK (9/6 Mbps) |
| Transmission speed | |
| IEEE 802.11b | 11 Mbps, 5.5 Mbps, 2 Mbps, 1 Mbps |
| IEEE 802.11g | 54 Mbps, 48 Mbps, 36 Mbps, 24 Mbps, 18 Mbps, 12 Mbps, 9 Mbps, 6 Mbps |
| Operation range** | Approx. 30 m |
| Frequency range | 2,412 MHz–2,472 MHz |
| Channels | 1–13 ch |

Supplied Accessories

- Card remote control
- Lithium battery for remote control
- Power cord
- RGB signal cable
- Carrying bag
- Software CD-ROM (PT-LB20NTE)

Optional Accessories

| | |
|----------|--|
| ET-LAB10 | Replacement lamp unit |
| ET-PKB30 | Ceiling mount bracket |
| ET-RM300 | Full-function wireless remote control |
| ET-ADSER | Serial adaptor (DIN 8-pin/D-sub 9-pin) |

*1: In All mode. *2: Height including protruding parts and legs: 73 mm (2-27/32").

*3: Operation range differs depending on the environment.

Dimensions

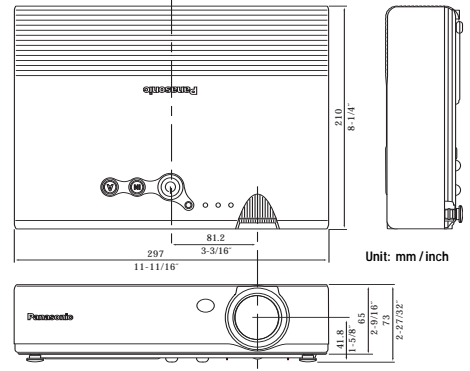

To use wireless functions, a PC is required that meets the conditions given below:

| | |
|------------------------------|---|
| OS: | Windows XP Home Edition, Windows XP Professional, Windows 2000 Professional, Windows Me (Millennium Edition) or Windows 98SE (Second Edition) |
| CPU: | Pentium III or higher, or other compatible processor (800 MHz or higher recommended when using the live mode; 1 GHz or higher is recommended when playing movies). |
| Memory: | 128 MB or more (256 MB or more for Windows XP or Windows 2000) |
| Free hard disk space: | 60 MB or more |
| Hardware conditions: | CD-ROM drive (for software installation and viewing the user's manual). An 802.11b/g built-in wireless LAN system or external 802.11b/g LAN card must be installed and running normally. However, some 802.11b/g wireless LAN may not allow connection to 802.11g projectors. The data transfer speed will be lower with an 802.11b LAN than that with an 802.11g LAN. |
| Web browser: | Internet Explorer 6.0 or later, Netscape Communicator 7.0 or later |
| Direct X: | DirectX® 8.1b or later must be installed. |

NOTES ON USE

- The projector uses a high-voltage mercury lamp that contains high internal pressure. This lamp may break, emitting a large sound, or fail to illuminate, due to impact or extended use. The length of time that it takes for the lamp to break or fail to illuminate varies greatly depending on individual lamp characteristics and usage conditions.
- The brightness of the lamp will gradually decrease with use.
- The lamp, LCD panel, polarizing plate, and polarizing beam splitter (PBS) are consumable parts. These parts may need to be replaced during the guarantee period if the projector is used for six or more hours per day.
- The replacement cycle of the LCD panel, polarizing plate, and polarizing beam splitter (PBS) will be shortened if the projector is subjected to continuous use for six or more hours. Likewise, the replacement cycle of the lamp will be shortened if the power is frequently turned on and off or the projector is subjected to continuous use for 10 or more hours.

Projection Distance

PT-LB20NTE/LB20E

| Diagonal image size (4:3 aspect ratio) | Distance to screen | | Height from the edge of screen to centre of lens |
|---|--------------------|----------------|--|
| | min. | max. | |
| 33' / 0.84 m / 2.7' | – | 1.1 m / 3.6' | 8 cm / 3.1' |
| 40' / 1.02 m / 3.3' | 1.2 m / 3.9' | 1.4 m / 4.6' | 9 cm / 3.5' |
| 50' / 1.27 m / 4.2' | 1.5 m / 4.9' | 1.7 m / 5.6' | 11 cm / 4.3' |
| 60' / 1.52 m / 4.9' | 1.8 m / 5.9' | 2.1 m / 6.9' | 14 cm / 5.5' |
| 70' / 1.78 m / 5.8' | 2.1 m / 6.9' | 2.4 m / 7.9' | 16 cm / 6.3' |
| 80' / 2.03 m / 6.7' | 2.4 m / 7.9' | 2.8 m / 9.2' | 18 cm / 7.1' |
| 90' / 2.29 m / 7.5' | 2.7 m / 8.9' | 3.2 m / 10.5' | 20 cm / 7.9' |
| 100' / 2.54 m / 8.3' | 3.0 m / 9.8' | 3.5 m / 11.5' | 22 cm / 8.7' |
| 120' / 3.05 m / 10.0' | 3.6 m / 12.5' | 4.2 m / 13.8' | 26 cm / 10.2' |
| 150' / 3.81 m / 12.5' | 4.5 m / 14.8' | 5.3 m / 17.4' | 33 cm / 13.0' |
| 200' / 5.08 m / 16.7' | 6.0 m / 19.7' | 7.1 m / 23.3' | 44 cm / 17.3' |
| 250' / 6.35 m / 20.8' | 7.5 m / 24.6' | 8.9 m / 29.2' | 55 cm / 21.7' |
| 300' / 7.62 m / 25.0' | 9.0 m / 29.5' | 10.7 m / 35.1' | 66 cm / 26.0' |

PT-LB20SE

| Diagonal image size (4:3 aspect ratio) | Distance to screen | | Height from the edge of screen to centre of lens |
|---|--------------------|----------------|--|
| | min. | max. | |
| 33' / 0.84 m / 2.7' | – | 1.1 m / 3.6' | 8 cm / 3.1' |
| 40' / 1.02 m / 3.3' | 1.2 m / 3.9' | 1.4 m / 4.6' | 9 cm / 3.5' |
| 50' / 1.27 m / 4.2' | 1.5 m / 4.9' | 1.8 m / 5.9' | 11 cm / 4.3' |
| 60' / 1.52 m / 4.9' | 1.8 m / 5.9' | 2.1 m / 6.9' | 14 cm / 5.5' |
| 70' / 1.78 m / 5.8' | 2.1 m / 6.9' | 2.5 m / 8.3' | 16 cm / 6.3' |
| 80' / 2.03 m / 6.7' | 2.4 m / 7.9' | 2.9 m / 9.5' | 18 cm / 7.1' |
| 90' / 2.29 m / 7.5' | 2.8 m / 9.2' | 3.2 m / 10.5' | 20 cm / 7.9' |
| 100' / 2.54 m / 8.3' | 3.0 m / 9.8' | 3.6 m / 11.8' | 22 cm / 8.7' |
| 120' / 3.05 m / 10.0' | 3.7 m / 12.1' | 4.3 m / 14.1' | 26 cm / 10.2' |
| 150' / 3.81 m / 12.5' | 4.6 m / 15.1' | 5.4 m / 17.7' | 33 cm / 13.0' |
| 200' / 5.08 m / 16.7' | 6.1 m / 20.0' | 7.3 m / 24.0' | 44 cm / 17.3' |
| 250' / 6.35 m / 20.8' | 7.6 m / 24.9' | 9.1 m / 29.9' | 55 cm / 21.7' |
| 300' / 7.62 m / 25.0' | 9.2 m / 30.2' | 11.0 m / 36.1' | 66 cm / 26.0' |

PT-LB20VE

| Diagonal image size (4:3 aspect ratio) | Distance to screen | | Height from the edge of screen to centre of lens |
|---|--------------------|----------------|--|
| | min. | max. | |
| 33' / 0.84 m / 2.7' | – | 1.4 m / 4.6' | 4 cm / 1.6' |
| 40' / 1.02 m / 3.3' | 1.4 m / 4.6' | 1.7 m / 5.6' | 5 cm / 2.0' |
| 50' / 1.27 m / 4.2' | 1.7 m / 5.6' | 2.1 m / 6.9' | 6 cm / 2.4' |
| 60' / 1.52 m / 4.9' | 2.1 m / 6.9' | 2.5 m / 8.2' | 7 cm / 2.8' |
| 70' / 1.78 m / 5.8' | 2.4 m / 7.9' | 2.9 m / 9.5' | 8 cm / 3.1' |
| 80' / 2.03 m / 6.7' | 2.8 m / 9.2' | 3.4 m / 11.2' | 9 cm / 3.5' |
| 90' / 2.29 m / 7.5' | 3.1 m / 10.2' | 3.8 m / 12.5' | 11 cm / 4.3' |
| 100' / 2.54 m / 8.3' | 3.5 m / 11.5' | 4.2 m / 13.8' | 12 cm / 4.7' |
| 120' / 3.05 m / 10.0' | 4.2 m / 13.8' | 5.0 m / 16.4' | 14 cm / 5.5' |
| 150' / 3.81 m / 12.5' | 5.2 m / 17.0' | 6.3 m / 20.7' | 18 cm / 7.1' |
| 200' / 5.08 m / 16.7' | 7.0 m / 22.9' | 8.4 m / 27.6' | 23 cm / 9.1' |
| 250' / 6.35 m / 20.8' | 8.7 m / 28.5' | 10.6 m / 34.8' | 29 cm / 11.4' |
| 300' / 7.62 m / 25.0' | 10.5 m / 34.4' | 12.7 m / 41.7' | 35 cm / 13.8' |

Panasonic

Weights and dimensions shown are approximate. Specifications are subject to change without notice. Product availability differs depending on region and country. This product may be subject to export control regulations. UHM is a trademark of Matsushita Electric Industrial Co., Ltd. VGA and XGA are trademarks of International Business Machines Corporation. Windows and PowerPoint are either registered trademarks or trademarks of Microsoft Corporation in the United States and/or other countries. All other trademarks are the property of their respective trademark owners. Projection images simulated.

