

H.264 x12 PTZ NETWORK CAMERA

ZN-PTZ12VP-XT

ZN-PTZ12VN-XT

Installation Manual

GAWZ®

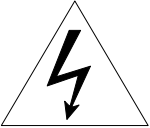
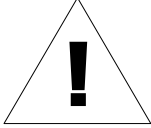

INFORMATION TO USER

	CAUTION RISK OF ELECTRIC SHOCK, DO NOT OPEN	
<p>CAUTION: TO REDUCE THE RISK OF ELECTRIC SHOCK, DO NOT REMOVE COVER (OR BACK). NO USER SERVICEABLE PARTS INSIDE. REFER SERVICING TO QUALIFIED SEERVICVE PERSONEL.</p>		

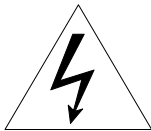

This symbol is intended to alert the user to the presence of un-insulated “dangerous voltage” within the product’s enclosure that may be of sufficient magnitude to constitute a risk of electric shock to persons.



This symbol is intended to alert the user to the presence of important operating and maintenance (servicing) instructions in the literature accompanying the appliance.

Table of Contents

1. FEATURES	4
2. PACKAGE CONTENTS	5
3. PART NAMES	6
4. INSTALLATION	8
4.1. Installation Template.....	9
4.2.Setting the Image Attribute	10
4.3.Operating the OSD Menu	10
5. CONNECTIONS	11
5.1.Connectors.....	11
6. CONFIGURATION	14
6.1.Set up network environment.....	14
6.2. View video on web page.....	14
6.2.1. View video using IPAdmin Tool	14
6.2.2. View video using IP address.....	16
6.3. Reset.....	16
6.4. Factory Default.....	16
APPENDIX (A): SPECIFICATIONS.....	17
Summary	17
Electrical Characteristics	18
Environment Condition	18
APPENDIX (B): DIMENSIONS.....	19
APPENDIX (C): HEXADECIMAL-DECIMAL CONVERSION TABLE	20
REVISION HISTORY	21

1. FEATURES

Camera

- Indoor/Outdoor Mini PTZ Dome IP Camera (Vandal Proof)
- Sony 1/4" Super HAD CCD, 410K Pixel
- x12 Optical Zoom, x16 Digital Zoom (Max x192)
- True Day & Night (IR Cut Filter, DSS)
- 360° endless rotation
- Intelligent pan/tilt controlling
- Improvement of color rolling suppression

Streaming

- Dual streaming mode (such as different codec/resolution/bit rate and so on.)
- De-interlacing on DSP
- Burnt-in text supported
- Unicast/Multicast supported

Video/Audio

- Video compression: H.264/MPEG4/MJPEG, 25/30FPS@D1(PAL/NTSC)
- Audio compression: G.711(μLaw, aLaw)/PCM
- Analog video out for external monitors
- Video Motion Detection supported
- Two-way mono audio supported

Network

- RTSP/ HTTP protocol supported
- 10/100 Base-T Ethernet

Additional Features

- RS-485 supported
- Micro SD card socket for external storage
- OSD supported
- SDK (Software Development Kit) provided

VCA (Video Content Analysis)

- VCA Presence (Included as basic)
- VCA Surveillance (Optional)

2. PACKAGE CONTENTS

Unpack carefully and handle the equipment with care. The packaging contains:

Camera

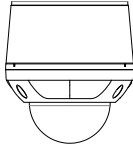

DC power adaptor

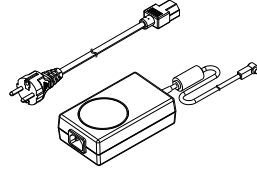

Terminal block

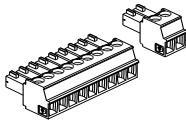

Installation Template

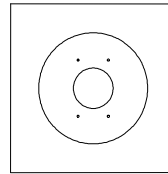

Power adaptor jack

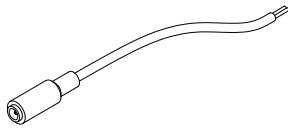

Screws and Anchor blocks



Video BNC cable

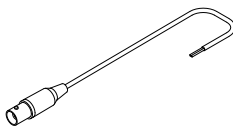

Hex wrench driver

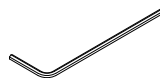

Quick Installation Guide

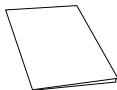

The above contents are subject to change without prior notice.

3. PART NAMES

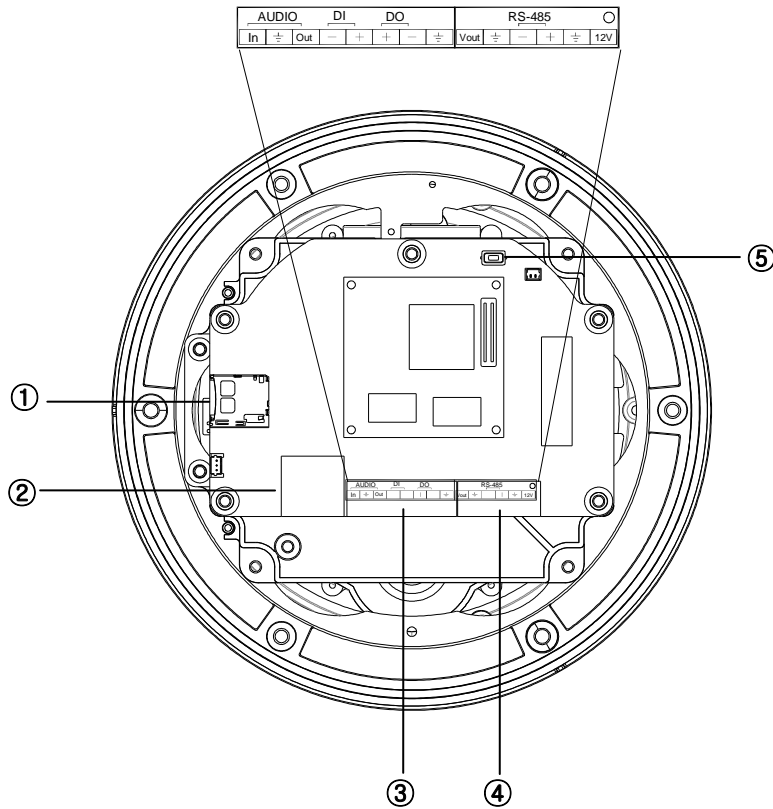

* Models herein and their appearance are subject to change without any prior notice.

① Micro SD Card Socket

It is a memory card slot for external storage.

② LAN Connector (Ethernet)

This is a RJ45 LAN connector for 10/100 Base-T Ethernet.

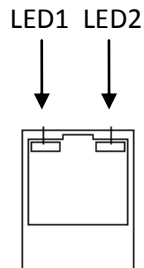

This LED lights up as orange and turns green when the encoder is powered on.

LED operation setting:

For the factory default setting, LED 2 blinks for the heartbeat and LED 1 turns on for video signal. To change its setting, refer to the section **4.5.11. LED Setting** of the **NVC Web Page User's Manual**.

③ 8 pin terminal block for audio, DI, and DO

Refer to the section “**5.1.Connectors**” for more specific information.

④ 6 pin connector for analog video output, RS485, and power

Refer to the section “**5.1.Connectors**” for more specific information.

⑤ Reset

Reset switch is used for restarting the camera or resetting it to Factory Default (FD). Refer to the section “**6.3. Reset**” for more specific information.

4. INSTALLATION

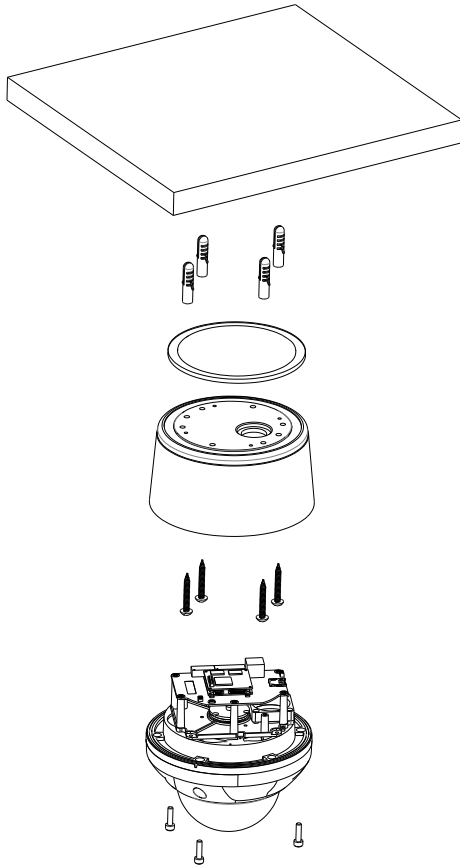

1) Connect the LAN cable, power supply cable, and the video loop out cable with the camera.

2) Place the installation template on the ceiling.

3) Drill four holes on the template and insert anchor blocks into the holes. Fasten the surface mount bracket with screws.

4) Put the main body on the surface mount bracket of the camera. Make sure the bracket and the main body fit each other into place.

5) Fasten the main body with screws.



Note

When assembling the main body of the camera and its dome cover, make sure they fit each other into place.



The camera may fall off the ceiling even after the proper installation and mounting. To prevent any accident, make sure the ceiling is firm and stable enough to support the camera. If any reinforcement is needed, consult with your safety personnel and proceed with the installation.

4.1. Installation Template

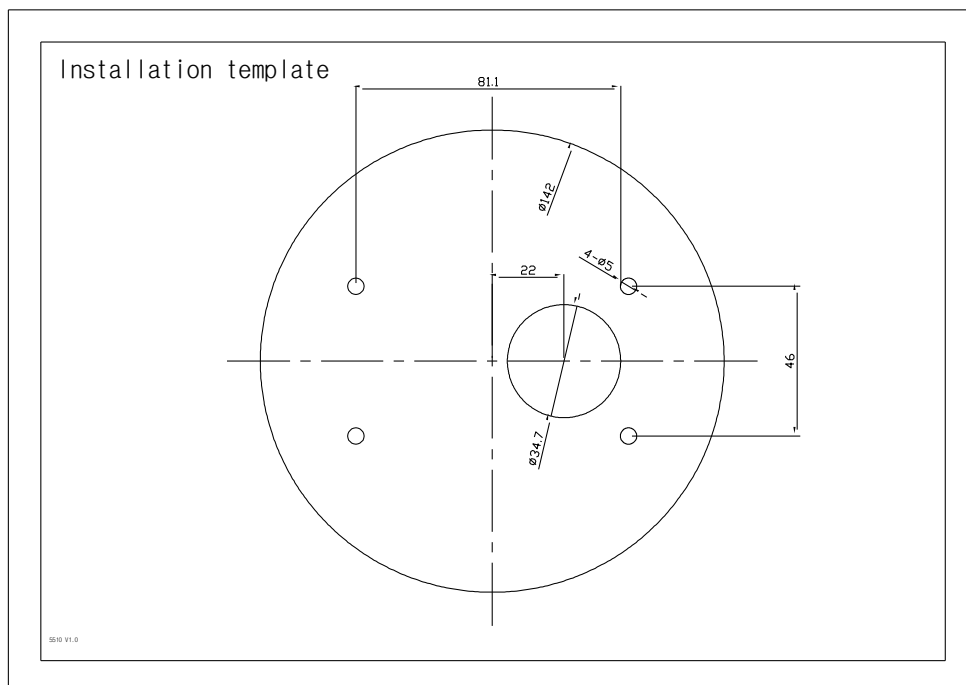

4.2.Setting the Image Attribute

You can set the image attribute of camera through the webpage.

The menu of image attribute can be seen under **Setup > Video & Audio > Video-in > Attribute Setting**. Brightness, contrast, hue, saturation and sharpness can be adjusted.

4.3.Operating the OSD Menu

To operate the OSD of camera, refer to the "OSD Menu Control Manual."

5. CONNECTIONS

5.1.Connectors

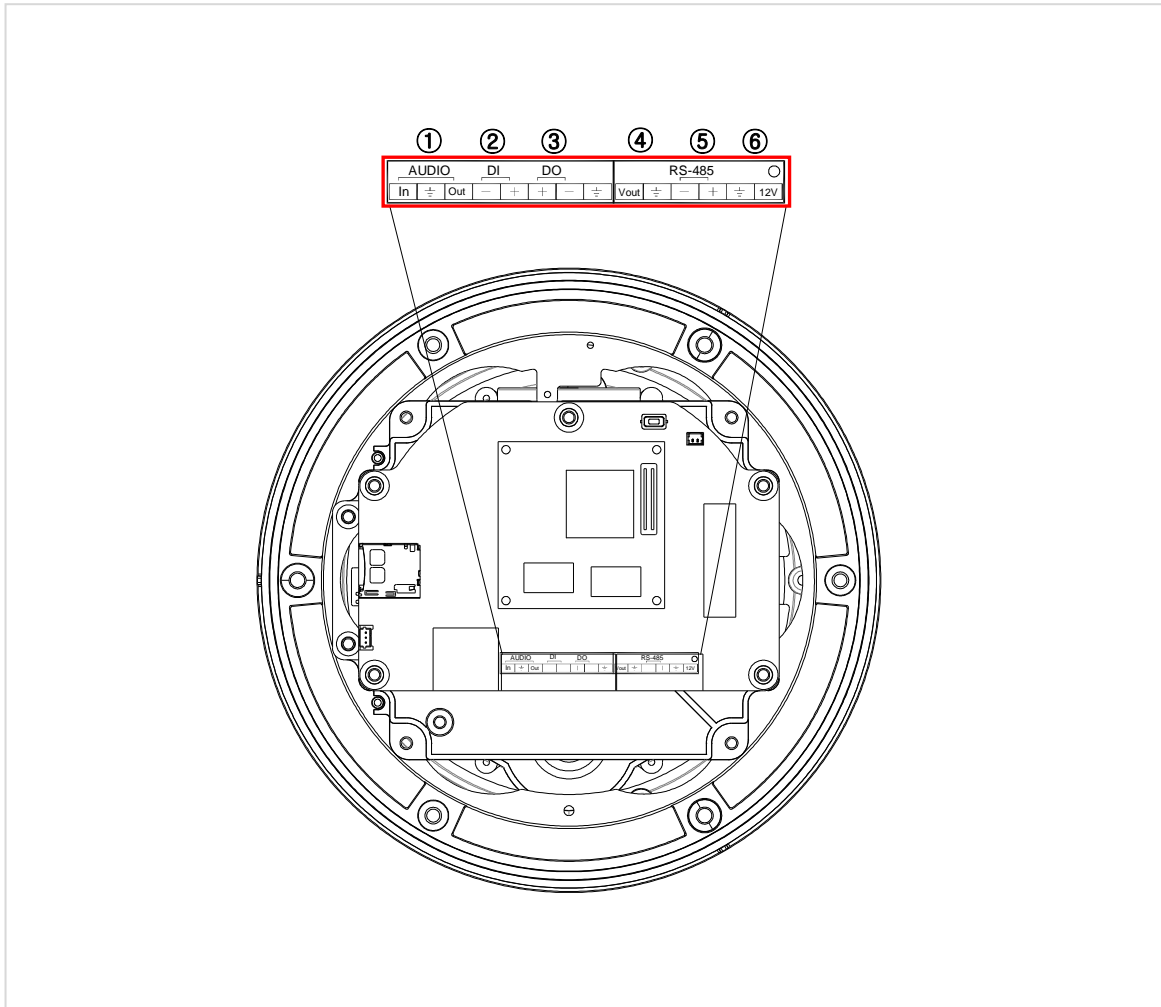

① Audio Input/Output Connection

Connect to the audio input device such as a mike and the audio output device such as the amplifier speaker.

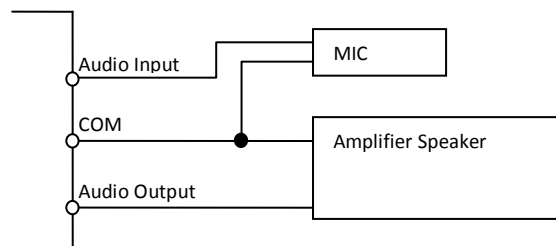

Audio Input : Linein, 1.43Vp-p (Min 1.35Vp-p, max 1.49 Vp-p), 39 K Ω

Audio Output : Lineout, 46mW Power, 16 Ω



Do not connect the speaker without amplifier.

② **Sensor (DI) connection**

The camera provides 1 channel D/I. It can be connected to either a voltage type sensor or a relay type sensor as the following figures. It can be selected by software.

Input voltage range: 0VDC minimum to 5VDC maximum, Max 50mA

Input voltage threshold: 4.5V



Do not exceed the maximum input voltage or relay rate.

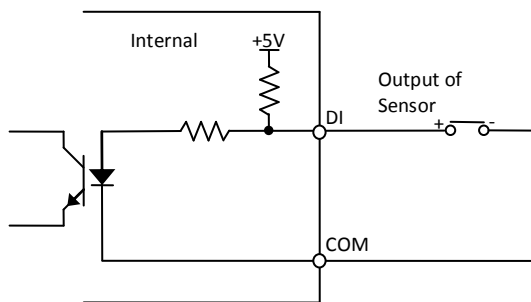

Relay Type

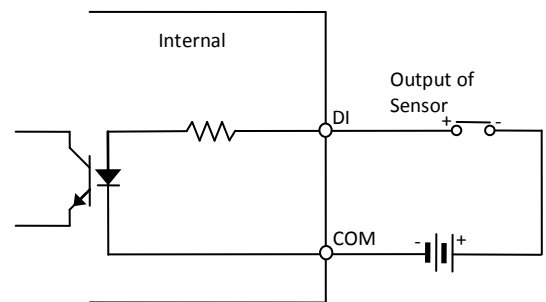

Voltage Type

③ **Alarm (DO) connection**

The camera provides 1 channel D/O.

Relay Rating: Max 24VAC 500mA or 12VDC 1A



Do not exceed the maximum relay rating.

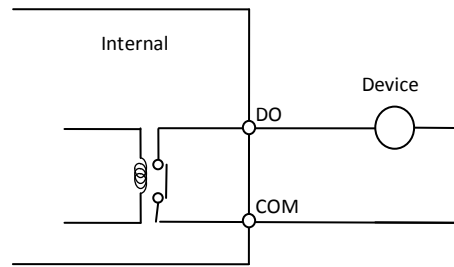

Relay Type

④ Analog video out

Connect with BNC coaxial cable.

⑤ RS-485 Communication

For PTZ control, connect this line to keyboard.

⑥ Power Connection

Please, check the voltage and current capacity of rated power carefully.

Rated Power	Input Voltage Range	Current Consumption
DC 12V	DC 8V ~ 16V	1 A

6. CONFIGURATION

6.1. Set up network environment

The default IP address of your IP device is 192.168.XXX.XXX. You can find the available IP address from the MAC address of your device. Please make sure the device and your PC are on the same network segment before running the installation. If the network segment between your PC and the device is different, change your PC's settings as below.

IP address : **192.168.xxx.xxx**

Subnet mask: **255.255.0.0**

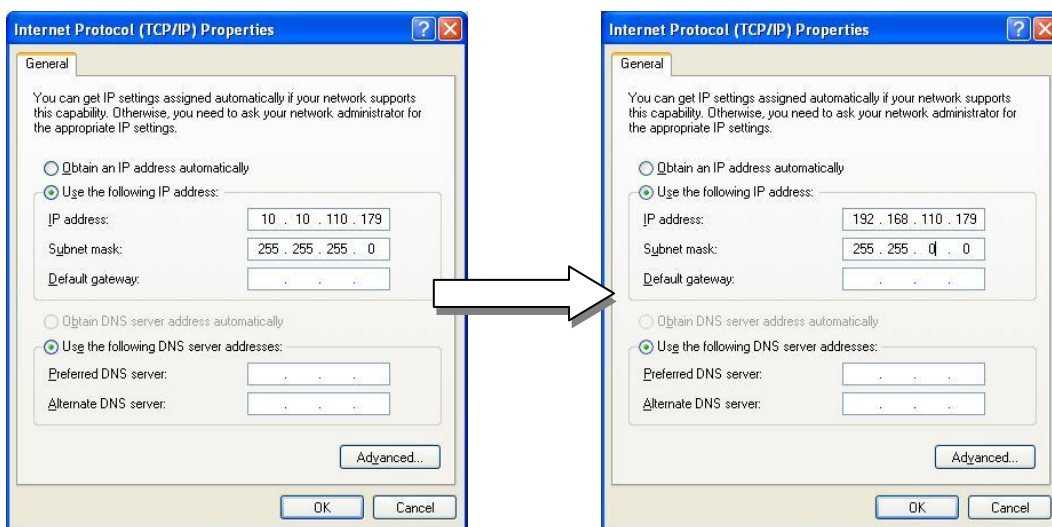

6.2. View video on web page

View the live video on a web page using your IP device and its IP address. You can use the IPAdminTool or enter the IP address on the web page.

6.2.1. View video using IPAdmin Tool

IPAdminTool automatically searches all activated network encoders and IP cameras and shows the product name, IP address, MAC address and etc. IPAdminTool is provided with SDK at the following SDK path.

```
{SDK root}\BIN\TOOLS\AdminTool\
```

To use the IPAdminTool and view the live video on a web page:

1. Start IPAdminTool. Names and info of currently activated devices appear as a list.
2. Right-click on the desired device and select **Web view**.
3. Click **pop-up blocked** and install the ActiveX setup.exe by clicking the **Run** or **Save** button. You need to install the ActiveX for displaying the images.



4. Follow the instructions of the dialog boxes and complete the installation. Then the live video is displayed on the main page of the web browser.
5. If the live video is not displayed with the message said, *"This software requires the Microsoft XML Parser V6 or higher. Please download MSXML6 from the Microsoft website to continue. Error code: Can not create XMLDOMDocument."*, please download and install the relevant MSXML.



If the ActiveX **setup.exe** file fails to be installed successfully, close all of the Internet Explorer windows and go to **Program Files > AxInstall** folder on your computer. Then, run **Uninstall.exe** and try to perform the steps 1 to 4 above again.

6.2.2. View video using IP address

View the live video on a web page using your IP device and its IP address. To have the correct IP address ready and use it on a web page:

1. Convert a MAC address to an IP address or check the IP address on the IPAdminTool. Refer to *Appendix (C): Hexadecimal-Decimal Conversion Table*.

(The MAC address is attached on the side or bottom of the device.)

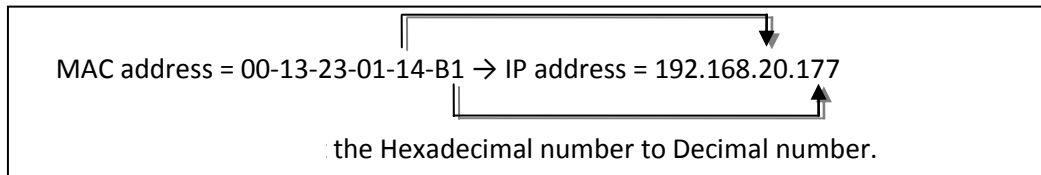

2. Open a web browser and enter the IP address of the device.
3. Click **pop-up blocked** and install the ActiveX setup.exe by clicking the **Run** or **Save** button. You need to install the ActiveX for displaying the images.
4. Follow the instructions of the dialog boxes and complete the installation. Then the live video is displayed on the main page of the web browser.

6.3. Reset

1. While the device is in use, press and hold the Reset button.
2. Release the Reset button after 3 seconds.
3. Wait for the system to reboot.

6.4. Factory Default

1. Disconnect the power supply from the device.
2. Connect the power to the device with the Reset button pressed and held.
3. Release the Reset button after 5 seconds.
4. Wait for the system to reboot.

The factory default settings can be inferred as follows:

IP address:	192.168.xx.yy
Network mask:	255.255.0.0
Gateway:	192.168.0.1
User ID:	root
Password:	pass

APPENDIX (A): SPECIFICATIONS

Summary

Camera Module	
Image Sensor	Sony 1/4" Super HAD CCD
Effective Pixels	811 x 508 (NTSC) / 795 x 596 (PAL)
TV System	NTSC / PAL
Horizontal Resolution	580 TVL (Color), 680 TVL (B/W)
Zoom	X12 Optical Zoom, x16 Digital Zoom
Focal length	F1.67~1.88, f=3.94~46.05mm
Sync System	Internal (12 VDC)
Min. Illumination	0.7 Lux(Color) / 0.02 Lux(B/W), 50 IRE
Lens	10X Optical Day & Night F1.8 f=3.8 ~ 38.0 mm
Iris	Auto / Manual
Day & Night	Auto / Day / Night(ICR)
S / N Ratio	52 dB
BLC	On/Off
Flickerless	On/Off
SSNR	Yes
Dome	
Pan Angle / Speed	360° Endless Rotation, Manual: 0.05° ~ 150°/sec / Preset: Max 250°/sec
Tilt Angle / Speed	-2° ~ 90°, Manual: 0.05° ~150°/sec / Preset: Max 250°/sec
Auto Scan	Programmable Auto scan
Pattern	8 Programmable Patterns (total 480 seconds)
Sector	8 selectable Sectors with 16 characters
On Screen Display	Yes
Video	
Compression	H.264, MPEG-4, MJPEG Selectable per Stream
Number of Streams	Dual stream, Configurable
Resolution	D1, 4CIF, 2CIF, VGA, CIF, QCIF, QVGA
Compression FPS	25/30 fps @ D1 (PAL/NTSC)
De-interlacing	Support (DSP)
Motion Detection	Support
Burnt-in Text(digital)	Support (DSP)
Analog Video Output	1 Loop Out (Terminal Block)
Audio	

Input / Output	1 / 1 Ch
Compression	PCM, G.711
Function	
Network	10/100 Base-T
DI / DO	1 / 1 Ch
RS-485	Support
Protocol	TCP/IP, UDP/IP, HTTP, RTSP, RTCP, RTP/UDP, RTP/TCP, SNTP, mDNS, UPnP, SMTP, SOCK, IGMP, DHCP, FTP, DDNS, SSL v2/v3, IEEE 802.1X, SSH, SNMP v2/v3
SD memory	Micro SD card slot ※ Micro SD Card is not included
Mechanical	
Material	Aluminum Die Casting / Polycarbonate
Dimensions	Housing : Housing: 157(Φ) x 178(H) mm
Color	Ivory
Weight	1,900 g

Electrical Characteristics

Power Source	12V DC
Power Consumption (Approx.)	1400mA
Analog Video Output	1 Vp-p, 75Ω, Composite
Audio Input	Linein, 1.43Vp-p (Min 1.35Vp-p, max 1.49 Vp-p), 39 KΩ
Audio Output	Lineout, 46mW Power, 16 Ω
Sensor(D/I)	Max 50mA@5VDC, TTL level 4.5V threshold
Alarm(D/O)	Max 500mA@24VAC or 1A@12VDC On-state resistance: 50 Ω (max continuous)

Environment Condition

Operating Temperature	Operating Range DC12V : -40°C ~ 50°C (-40°F ~ 122°F) Cold Start DC12V : -10°C (14°F)
Storage Temperature	-20 °C ~ 60 °C (-4°F ~ 140 °F)
Operating Humidity	Up to 85% RH

APPENDIX (B): DIMENSIONS

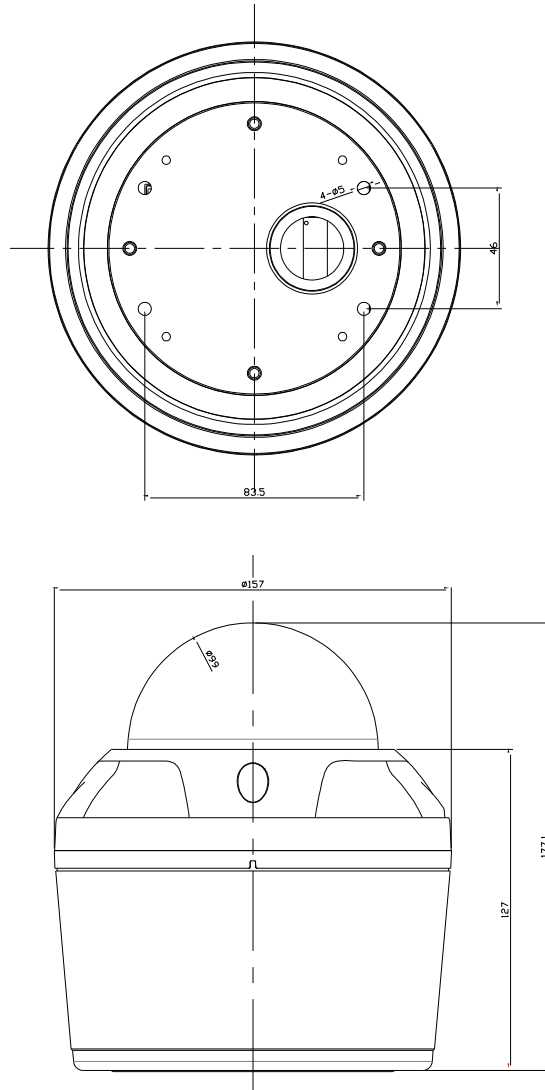

(Unit: mm)

APPENDIX (C): HEXADECIMAL-DECIMAL CONVERSION TABLE

Refer to the following table when you convert the MAC address of your device to IP address.

Hex	Dec	Hex	Dec	Hex	Dec	Hex	Dec	Hex	Dec	Hex	Dec	Hex	Dec
00	0	25	37	4A	74	6F	111	94	148	B9	185	DE	222
01	1	26	38	4B	75	70	112	95	149	BA	186	DF	223
02	2	27	39	4C	76	71	113	96	150	BB	187	E0	224
03	3	28	40	4D	77	72	114	97	151	BC	188	E1	225
04	4	29	41	4E	78	73	115	98	152	BD	189	E2	226
05	5	2A	42	4F	79	74	116	99	153	BE	190	E3	227
06	6	2B	43	50	80	75	117	9A	154	BF	191	E4	228
07	7	2C	44	51	81	76	118	9B	155	C0	192	E5	229
08	8	2D	45	52	82	77	119	9C	156	C1	193	E6	230
09	9	2E	46	53	83	78	120	9D	157	C2	194	E7	231
0A	10	2F	47	54	84	79	121	9E	158	C3	195	E8	232
0B	11	30	48	55	85	7A	122	9F	159	C4	196	E9	233
0C	12	31	49	56	86	7B	123	A0	160	C5	197	EA	234
0D	13	32	50	57	87	7C	124	A1	161	C6	198	EB	235
0E	14	33	51	58	88	7D	125	A2	162	C7	199	EC	236
0F	15	34	52	59	89	7E	126	A3	163	C8	200	ED	237
10	16	35	53	5A	90	7F	127	A4	164	C9	201	EE	238
11	17	36	54	5B	91	80	128	A5	165	CA	202	EF	239
12	18	37	55	5C	92	81	129	A6	166	CB	203	F0	240
13	19	38	56	5D	93	82	130	A7	167	CC	204	F1	241
14	20	39	57	5E	94	83	131	A8	168	CD	205	F2	242
15	21	3A	58	5F	95	84	132	A9	169	CE	206	F3	243
16	22	3B	59	60	96	85	133	AA	170	CF	207	F4	244
17	23	3C	60	61	97	86	134	AB	171	D0	208	F5	245
18	24	3D	61	62	98	87	135	AC	172	D1	209	F6	246
19	25	3E	62	63	99	88	136	AD	173	D2	210	F7	247
1A	26	3F	63	64	100	89	137	AE	174	D3	211	F8	248
1B	27	40	64	65	101	8A	138	AF	175	D4	212	F9	249
1C	28	41	65	66	102	8B	139	B0	176	D5	213	FA	250
1D	29	42	66	67	103	8C	140	B1	177	D6	214	FB	251
1E	30	43	67	68	104	8D	141	B2	178	D7	215	FC	252
1F	31	44	68	69	105	8E	142	B3	179	D8	216	FD	253
20	32	45	69	6A	106	8F	143	B4	180	D9	217	FE	254
21	33	46	70	6B	107	90	144	B5	181	DA	218	FF	255
22	34	47	71	6C	108	91	145	B6	182	DB	219		
23	35	48	72	6D	109	92	146	B7	183	DC	220		
24	36	49	73	6E	110	93	147	B8	184	DD	221		

REVISION HISTORY

MAN#	DATE(M/D/Y)	Comments
01A.01	12/219/2011	Created
01A.02	01/03/2012	Modified operating temperature