

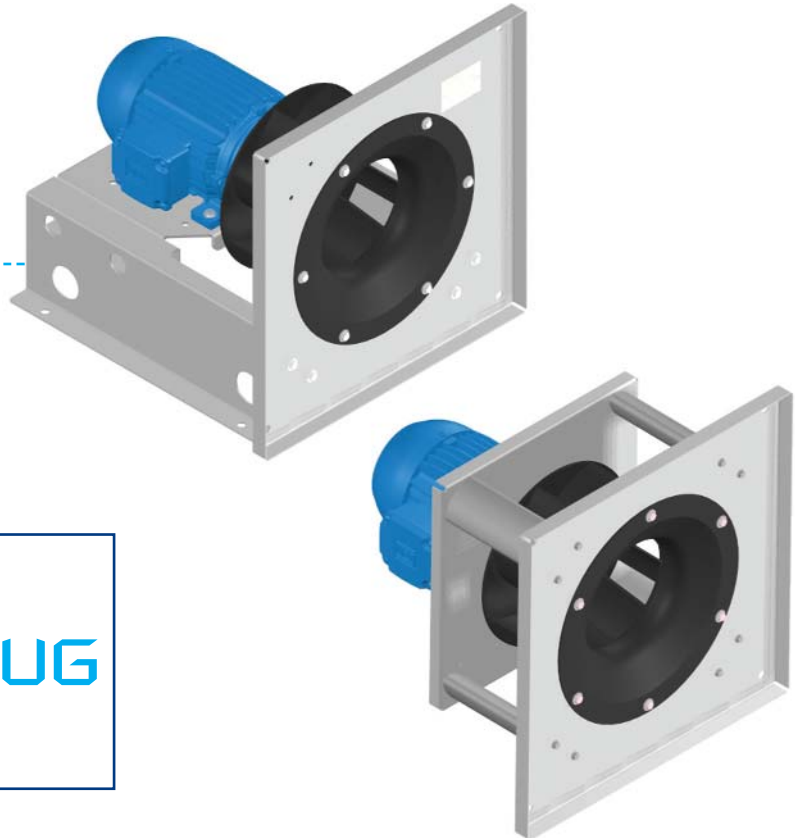

PLENUM FANS

*better AIRFLOW
by DESIGN™*



TEK PLENUM & PLUG FANS

- Modular construction, compact design
- OEM custom configurations available
- Horizontal and vertical applications
- Quiet, highly efficient performance
- Backward curved airfoil (BCA) wheel
- Non-overloading power characteristics
- Injection molded GRP polyamide TEK wheel
- TEFC industrial duty motors

TEK PLENUM FANS

STANDARD FEATURES & BENEFITS

- High efficiency, backward curved airfoil wheel
- Injection molded GRP polyamide TEK wheel
- TEFC industrial duty motors
- Supply and return air applications

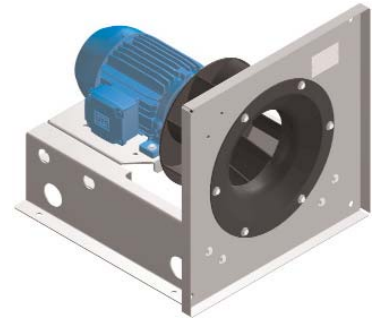

PERFORMANCE

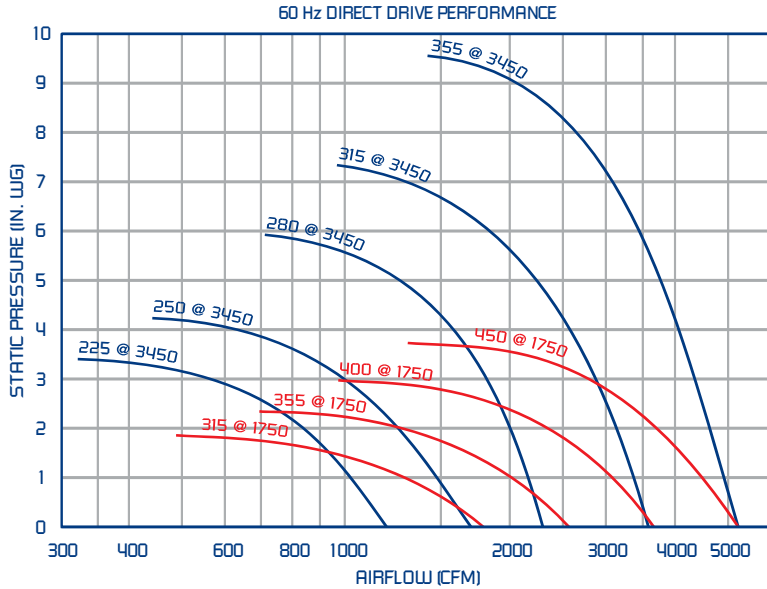

MOTOR HORSEPOWER		
MODEL	RPM	MTR HP
TEK225H-H2	3450	0.50
TEK250H-H2	3450	0.75
TEK280H-H2	3450	1.50
TEK315H-H4	1750	0.50
TEK315H-H2	3450	3.00
TEK355H-H4	1750	0.75
TEK355H-H2	3450	5.00
TEK400H-H4	1750	1.50
TEK450H-H4	1750	2.00

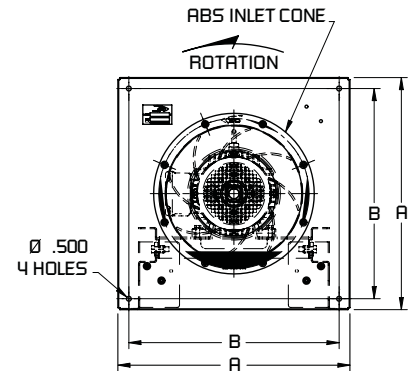
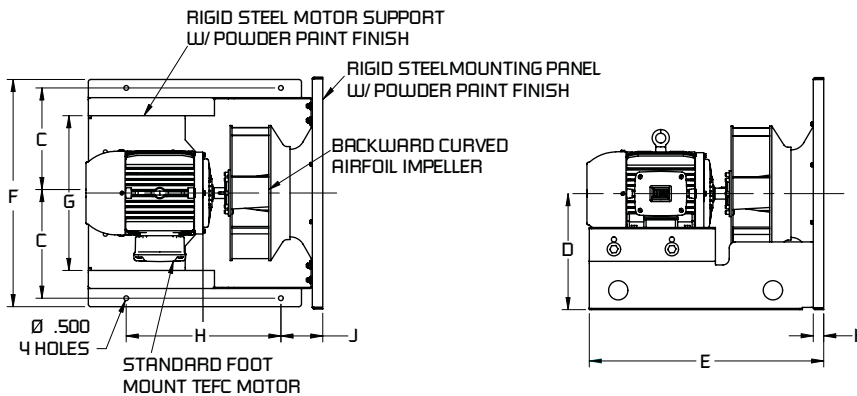

MODEL	DIMENSIONS IN INCHES*									
	A	B	C	D	E	F	G	H	J	K
TEK225H-H2	20.0	17.8	8.5	10.0	20.3	18.5	11.0	14.0	4.3	1.1
TEK250H-H2	20.0	17.8	8.5	10.0	20.3	18.5	11.0	14.0	4.3	1.1
TEK280H-H2	20.0	17.8	8.5	10.0	20.3	18.5	11.0	14.0	4.3	1.1
TEK315H-H4	24.0	21.8	10.9	12.0	24.3	23.5	16.0	16.0	4.3	1.1
TEK315H-H2	24.0	21.8	10.9	12.0	24.3	23.5	16.0	16.0	4.3	1.1
TEK355H-H4	24.0	21.8	10.9	12.0	24.3	23.5	16.0	16.0	4.3	1.1
TEK355H-H2	24.0	21.8	10.9	12.0	24.3	23.5	16.0	16.0	4.3	1.1
TEK400H-H4	28.0	25.8	12.5	14.0	26.6	27.3	16.0	20.0	4.6	1.1
TEK450H-H4	28.0	25.8	12.5	14.0	26.6	27.3	16.0	20.0	4.6	1.1

*DO NOT USE FOR CONSTRUCTION

CONSULT FACTORY FOR CERTIFIED PRINTS

TEK PLUG FANS

STANDARD FEATURES & BENEFITS

- High efficiency, backward curved airfoil wheel
- Injection molded GRP polyamide TEK wheel
- TEFC face mounted motors
- Horizontal and vertical applications

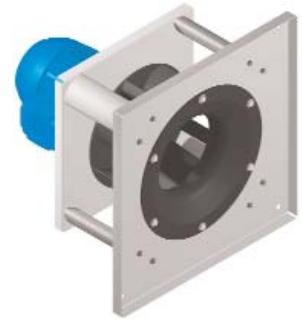

PERFORMANCE

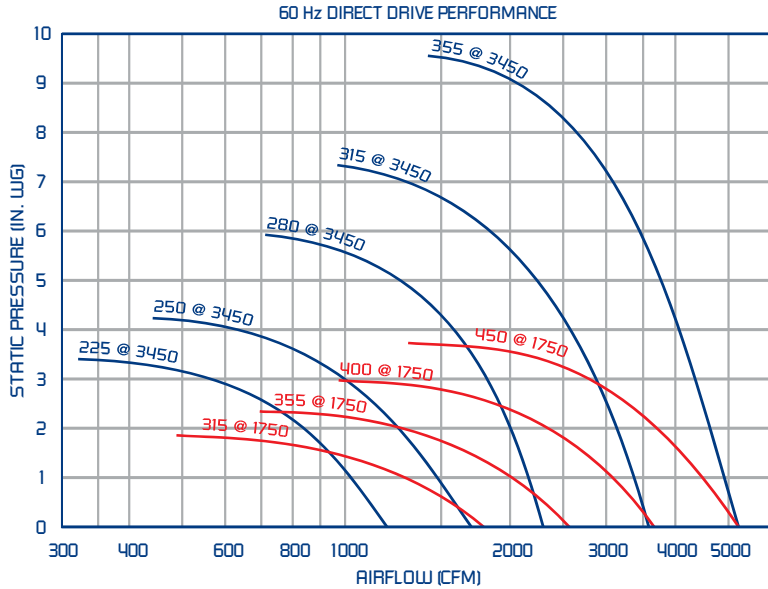

MOTOR HORSEPOWER		
MODEL	RPM	MTR HP
TEK225H-V2	3450	0.50
TEK250H-V2	3450	0.75
TEK280H-V2	3450	1.50
TEK315H-V4	1750	0.50
TEK315H-V2	3450	3.00
TEK355H-V4	1750	0.75
TEK355H-V2	3450	5.00
TEK400H-V4	1750	1.50
TEK450H-V4	1750	2.00

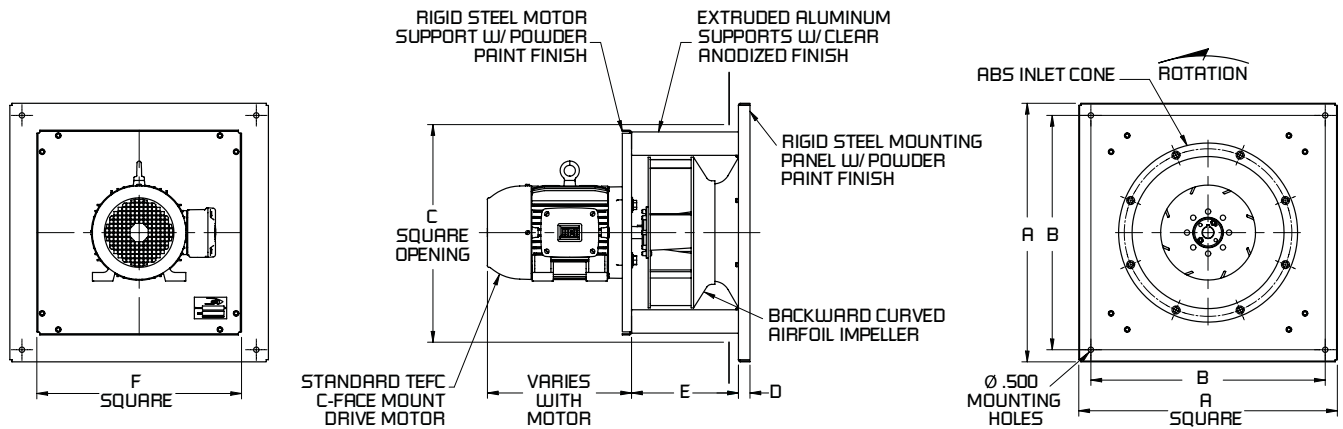

MODEL	DIMENSIONS IN INCHES*					
	A	B	C	D	E	F
TEK225H-V2	20.0	17.8	14.0	1.1	6.7	13.0
TEK250H-V2	20.0	17.8	15.0	1.1	7.4	14.0
TEK280H-V2	20.0	17.8	16.0	1.1	8.1	15.0
TEK315H-V4	24.0	21.8	17.5	1.1	9.1	17.0
TEK315H-V2	24.0	21.8	17.5	1.1	9.1	17.0
TEK355H-V4	24.0	21.8	19.5	1.1	9.9	19.0
TEK355H-V2	24.0	21.8	19.5	1.1	9.9	19.0
TEK400H-V4	28.0	25.8	20.5	1.1	10.8	20.0
TEK450H-V4	28.0	25.8	24.8	1.1	12.0	23.6

*DO NOT USE FOR CONSTRUCTION

CONSULT FACTORY FOR CERTIFIED PRINTS

Industrial Fan Division

The Industrial Fan Division offers superbly crafted industrial fans and ventilators, expertly supported by a network of independent manufacturers' representatives.

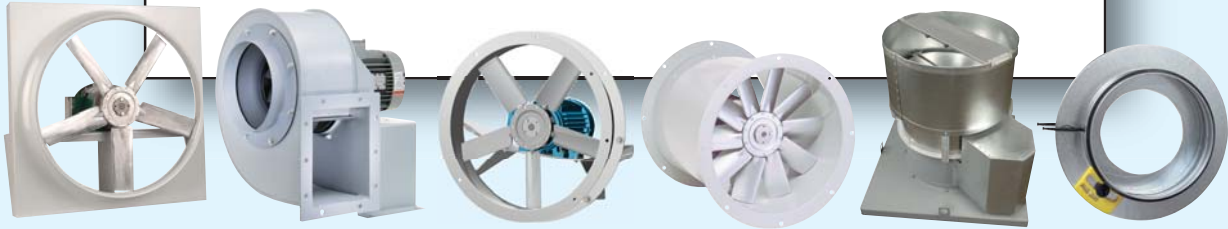

Panel Fans

Centrifugal Fans

Flange Fans

In-line Fans

Roof Ventilators

Iris Dampers

OEM Fan Division

The OEM Fan Division works closely with original equipment manufacturers to meet their design requirements, offering in-stock fan components, 3D models and custom fan solutions.



Cabinet Cooling Fans

Motorized Axials

Motorized Impellers

Centrifugal Fans

Axial Impellers

Centrifugal Impellers

Wholesale Products Division

The Wholesale Products Division offers a superior line of in-stock commercial and residential ventilation products, available from wholesalers and distributors across North America.



Bathroom Fans

Air Purification Systems

In-Line Duct Fans

External Mount Fans

Radial Blade Blowers

Exhaust Fans

USA

www.continentalfan.com

Continental Fan Manufacturing Inc.
203 Eggert Road, Buffalo, NY 14215
Tel: (716) 842 0670 Fax: (716) 842 0611

Canada

www.aeroflo.com

Aeroflo Inc.
12-205 Matheson Blvd. E., Mississauga, ON L4Z 3E3
Tel: (905) 890 6192 Fax: (905) 890 6193

TEK PLENUM & PLUG FANS

