

GFK-1439C
March 2010

96 MHz, 32-Bit Floating Point, 1 MByte Fast Memory Central Processing Unit for CPU Redundancy Applications

Features

- Required for CPU redundancy applications
- Supports floating point calculation
- Single slot CPU
- 12K inputs and 12K outputs (any mix)
- Up to 8K analog I/O
- 0.4 microseconds per boolean function
- 96 MHz, 80486DX4 microprocessor
- Supports IC660/IC661 and IC697 I/O products
- Programmed by MS-DOS® or Windows® based software products
- Supports 1 Mbyte of battery-backed fast CMOS RAM memory in the same slot
- Configurable data and program memory
- Battery-backed calendar clock
- Three position operation mode switch
- Password controlled access
- Keyswitch memory protection
- Seven status LEDs
- Software configuration (No DIP switches or jumpers to set)
- Reference information inside front door
- Three Series Ninety Protocol (SNP Slave) communications ports

Redundancy Features

In addition to the above features, the CGR935 supports the redundancy features listed below.

- Bumpless switching between redundancy PLCs
- Synchronization of CPUs
- Redundant backup communications
- 4.7 ms scan extension
- One scan switching (in most cases)
- Configurable backup data size
- On-line programming
- On-line repair
- No single point of failure (except for IC66* I/O Blocks and bus stubs)
- Same or different program in Primary and Secondary PLCs
- Program control switching

- Symptom status bits and fault tables
- Memory parity and checksums
- Common I/O on IC660/IC661 bus
- Manual switching with pushbutton switch on Redundancy Communications Module

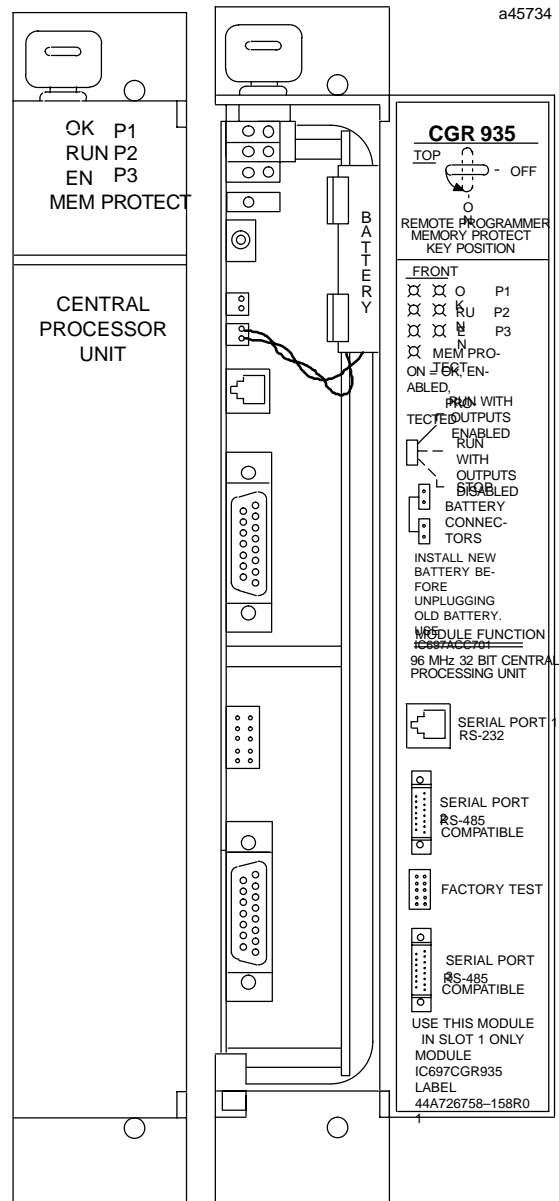

GFK-1439C
March 2010

96 MHz, 32-Bit Floating Point, 1 MByte Fast Memory Central Processing Unit for CPU Redundancy Applications

Functions

The CGR935 is a single slot programmable controller CPU which allows floating point calculations and is required for CPU redundancy applications. The CGR935 is programmed and configured by MS-DOS or Windows programming software to perform real time control of machines, processes and material handling systems.

The CGR935 communicates with I/O and smart option (specialty) modules over the rack mounted backplane (IC697CHS750, 790, 791) by way of the VME C.1 Standard format.

Supported option modules include all IC697 LAN interface modules, several Coprocessor modules, Bus Controller for IC660/IC661 I/O, Communications modules, and all of the IC697 family of discrete and analog I/O modules.

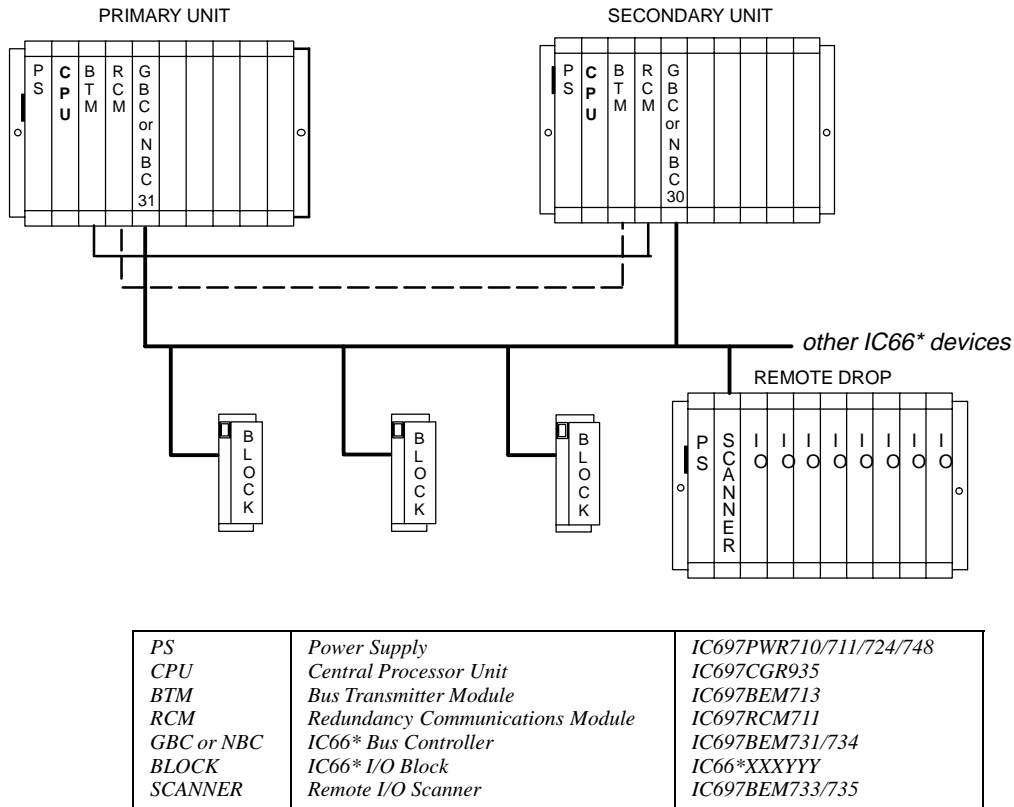

Figure 1. Typical Hot Standby CPU Redundancy System Configuration

User Memory

Program and data memory for the CGR935 is provided by a memory board with 1 MByte of battery-backed Fast CMOS RAM. This memory board is an integral part of the CGR935 and is included with the module. This memory board provides error checking through a CPU checksum routine with detected parity errors being reported to the CPU as they occur. Starting with firmware release 7.85 (October, 1998), increased program memory size was made available. See the *Important Product Information (IPI)* sheet, GFK-1440, that ships with the module for details.

Operation, Protection, and Module Status

Operation of this module may be controlled by the three position RUN/STOP switch or remotely by an attached programmer and programming software. Program and configuration data can be locked through software passwords or manually by the memory protect keyswitch. When the key is in the *protected* position, program and configuration data can only be changed by a programmer connected through parallel communications (that is, via the Bus Transmitter module). The status of the CPU is indicated by the seven green LEDs on the front of the module.

**96 MHz, 32-Bit Floating Point, 1 MByte Fast Memory
Central Processing Unit for CPU Redundancy Applications**

GFK-1439C
March 2010

CPU Redundancy Systems

The CGR935 is used as the controller in a CPU Redundancy system. Two redundancy control methods can be configured using the CGR 935. The GHS method (IC660/661 Hot Standby) uses multiple single bus IC660/661 I/O networks with one redundant controller in each synchronized PLC. The GDB method uses multiple I/O networks with either single or dual busses in each synchronized PLC with the capability of either unit being activated with bumpless switch. The location of the CGR935 modules in a typical Hot Standby CPU Redundancy system is shown in Figure 1.

Installation

It is the responsibility of the OEM, system integrator, or end user to properly install the PLC equipment for safe and reliable operation. Product manuals provide detailed information about installation, startup, and proper use of the PLC equipment. The installation manual, shipped with your PLC programming software, describes how to properly install the equipment. If the PLC installation must comply with supported standards, such as FCC or CE Directives, please refer to the *Installation Requirements for Conformance to Standards*, shipped with the PLC programming software, for additional guidelines.

Do not attempt installation without referring to the applicable *Programmable Controller Installation Manual* and the *Hot Standby CPU Redundancy Manual*.

- Connect the battery to either of the battery connectors on the module.
- Put keyswitch in Memory Protect OFF position.
- Make sure rack power is off.
- Install in slot 1 of rack 0. (See Figure 1)
- Turn on power. The module should power up and the top left (OK) LED should blink. When the diagnostics have completed successfully, the top left LED stays on and the second (RUN) and third (EN) LEDs are off. The fourth (bottom left) LED (MEM PROTECT) is off if the keyswitch is in the OFF position. The CPU is now ready to be programmed (if connected parallel, the CPU can be programmed regardless of key position). After the program has been verified, the toggle switch can be moved to the appropriate operation mode position; RUN WITH OUTPUTS ENABLED, RUN WITH OUTPUTS DISABLED, or STOP. The LEDs indicate the position of the toggle

switch, memory protection status, status of serial port activity, and the state of the program.

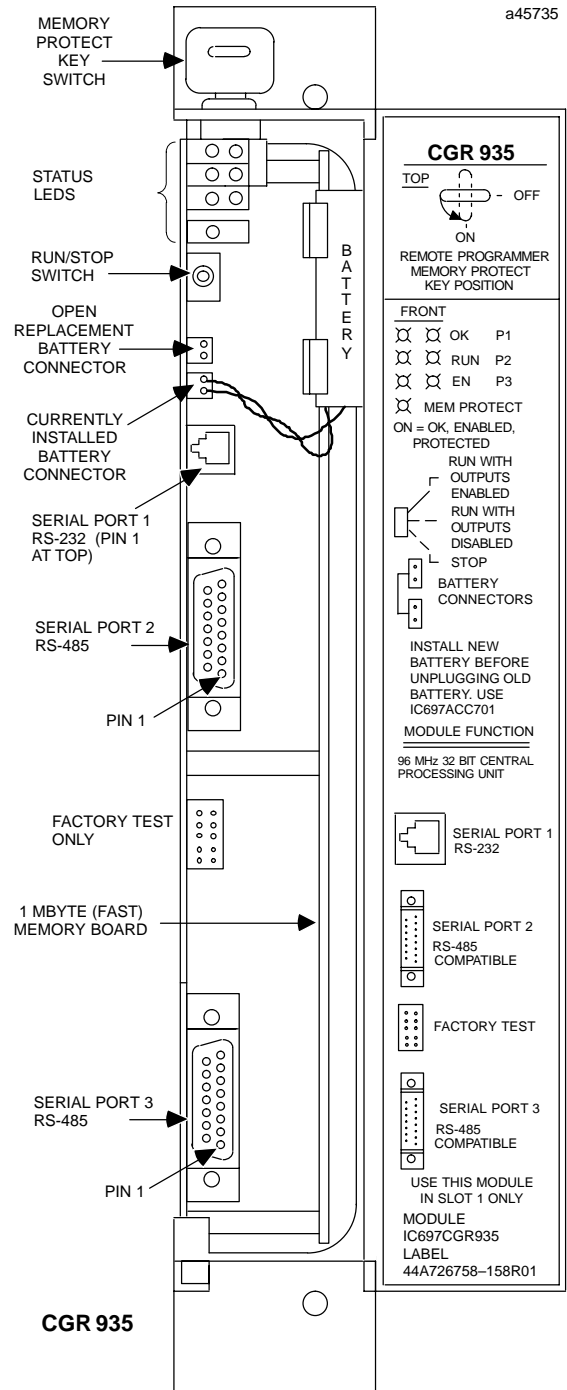

Figure 2. CGR 935 - Location of Major Features

GFK-1439C
March 2010

96 MHz, 32-Bit Floating Point, 1 MByte Fast Memory Central Processing Unit for CPU Redundancy Applications

Programmer Connection, Parallel Interface

The programmer connects to the top port on the Bus Transmitter Module (IC697BEM713) for a parallel interface (MS-DOS programmer only) as shown in Figure 1.

Connection to Serial Ports

The CGR935 has three on-board serial ports which can be configured to behave as three independent communications ports. These three ports are accessed by connections on the front of the module for serial interface to the programming computer, or other serial devices.

Ports 1 through 3 support SNP Slave protocol only. Ports 1 and 2 do not support program Load and Store or Datagrams. For details, see the Important Product Information sheet that ships with the module.

Protocols Supported

	Port 1	Port 2	Port 3
SNP	Yes	Yes	Yes
SNPX	No	No	No
RTU	Not supported	Not supported	Not supported

The programmer connection (shown below) is typically made from CPU serial Port 3 to the serial port on the programming computer, through an RS-422/RS-485 to RS-232 Converter (IC690ACC900) or RS-422 to RS-232 Miniconverter (IC690ACC901). This connection can be made with available cables or you may build cables to fit the needs of your particular application. See the IC697 *Programmable Controller Serial Communications Manual* for more information on serial communications.

Note

When configuring a CPU Redundancy system, the programmer must be connected to the CPU in the Primary unit to configure the Primary PLC and then moved to the CPU in the Secondary PLC to configure the Secondary PLC.

For more detailed information on configuration of Hot Standby CPU Redundancy systems and communications between PLCs in the system, refer to the *Hot Standby CPU Redundancy User's Guide*.

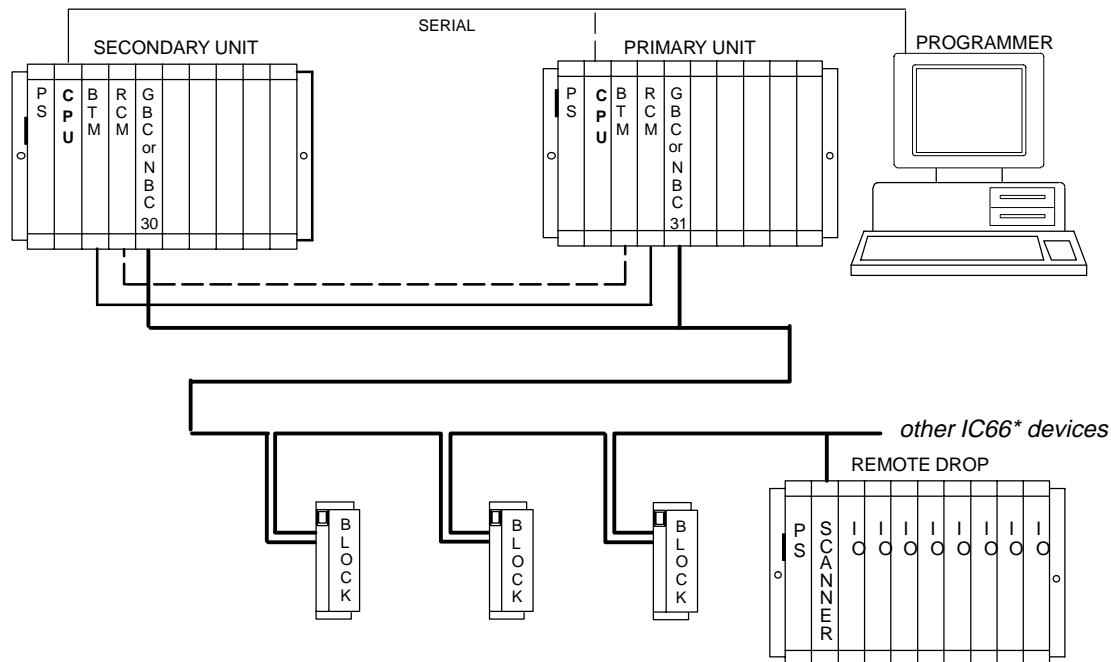

Figure 3. Hot Standby CPU Redundancy System Configuration with Serial Connection to Programmer

**96 MHz, 32-Bit Floating Point, 1 MByte Fast Memory
Central Processing Unit for CPU Redundancy Applications**

GFK-1439C
March 2010

CPU Serial Ports

Support for Port 1 and Port 2 was added in firmware release 7.85 (October, 1998). Prior releases only supported Port 3.

- **Port 1**, the top port, is RS-232 compatible. Port 1 has a 6-pin, female, RJ-11 connector. This connector is similar in appearance (although larger) to modular jacks commonly used for telephones and modems.

Table 1. Port 1 RS-232 Signals

Pin Number	Signal Name	Description
1 *	CTS	Clear To Send
2	TXD	Transmit Data
3	0V	Signal Ground
4	0V	Signal Ground
5	RXD	Receive Data
6	RTS	Request to Send

* Pin 1 is at the top of the connector as viewed from the front of the module.

- **Port 2**, the center port, is RS-485 compatible and is optocoupler isolated. Port 2 has a 15-pin, female D-connector.

Table 2. Port 2 RS-485 Signals

Pin Number	Signal Name	Description
1*	Shield	Cable Shield
2	NC	No Connection
3	NC	No Connection
4	NC	No Connection
5	+5VDC	Logic Power **
6	RTS(A)	Differential Request to Send
7	SG	Signal Ground
8	CTS(B')	Differential Clear To Send
9	RT	Resistor Termination
10	RD(A')	Differential Receive Data
11	RD(B')	Differential Receive Data
12	SD(A)	Differential Send Data
13	SD(B)	Differential Send Data
14	RTS(B')	Differential Request To Send
15	CTS(A')	Differential Clear To Send

*Pin 1 is at the bottom right of the connector as viewed from the front of the module.

** Note that Pin 5 provides Isolated +5 VDC power (100 mA maximum) for powering external options.

- **Port 3**, the bottom port, is also RS-485 compatible but is not isolated. Port 3 has a 15-pin, female D-connector. Pin assignments are found in the *IC697 PLC Installation Manual*.

Programmer Connection, Ethernet TCP/IP

Connecting your programmer via an Ethernet TCP/IP network requires installation of an Ethernet Interface module in the PLC. This can be either the Ethernet Controller, IC697CMM741, or Ethernet Interface (Type 2), IC697CMM742. Before connecting your programmer and PLC to the Ethernet TCP/IP network you must set the IP address in the Ethernet Interface. After setting the IP address, connect the PLC and the programmer running Windows software to the Ethernet Interface.

For more detailed information on Ethernet TCP/IP, refer to the *TCP/IP Ethernet Communications (Type 2) User's Manual*, and the Windows programming manual, GFK-1295.

Configuration

The IC697 CPU and I/O system is configured with MS-DOS or Windows based programming software. There are no DIP switches or jumpers used to configure the system. The CPU verifies the actual module and rack configuration at power-up and periodically during operation. The actual configuration must be the same as the programmed configuration. Deviations are reported to the CPU alarm processor function for configured fault response. Consult Reference 1 (Table 2.) for a description of configuration functions.

Batteries

A lithium battery (IC697ACC701) is installed as shown in Figure 2. This battery maintains program and data memory when power is removed and operates the calendar clock. Be sure to install the new battery before removing the old battery. If during power-up diagnostics a low battery is detected the Module OK LED (top) will not stay on. See the section "System Status References" in Chapter 2 of the IC697 PLC Reference Manual for more details about detecting a low battery condition.

GFK-1439C
March 2010

96 MHz, 32-Bit Floating Point, 1 MByte Fast Memory Central Processing Unit for CPU Redundancy Applications

Operation in High Ambient Temperatures

The CGR935 requires either forced air cooling or limiting of system power for operating in ambient temperatures greater than 50°C (122°F). A fan capable of 70 CFM (including filters) should be located beneath slot 1 of the rack containing the CPU.

Fan assemblies (IC697ACC721, IC697ACC724, and IC697ACC744) can be ordered for direct mounting on the IC697 rack. Refer to the *IC697 Programmable Controller Installation Manual* for detailed information.

For continuous operation above 50°C in a minimum size enclosure without forced air cooling, it is necessary to limit system power. De-rating data for the 100W AC/DC Power Supply (PWR711), and the 90W DC Power Supplies (PWR724/PWR748) is shown in the chart below.

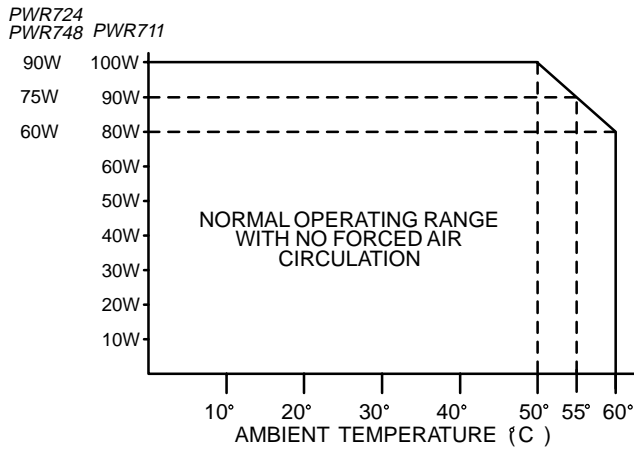

Table 3. Specifications for IC697CGR935 †

Battery	
Shelf life	5 years at 20° C (68° F)
Memory retention	6 months nominal without applied power.
Current required from 5V bus	3.1 Amps nominal
Operating Temperature	0 to 60°C (32°F to 140°F); 70 CFM forced air required 0 to 50°C (32°F to 122°F); without forced air
Time of Day Clock accuracy	" 3.5 seconds per day maximum
Elapsed Time Clock (internal timing) accuracy	" .01% maximum
Serial Ports	
Port 1: RS-232 compatible	Programmer Serial Attachment, or other serial devices.
Port 2: RS-485 compatible (optocoupler isolated)	Protocols supported: SNP Slave only
Port 3: RS-485 compatible (not isolated)	

† Refer to GFK-0867B, or later for product standards and general specifications. For installations requiring compliance to more stringent requirements (for example, FCC or European Union Directives), refer to *Installation Requirements for Conformance to Standards*.

Removing a Module

The following instructions should be followed when removing a CGR935 module from its slot in a rack. If a fault in the CPU hardware is detected that is logged as FATAL, the CPU will go to STOP mode and control will be switched from the active unit (with the failed CPU) to the backup unit. Power can then be removed from the rack containing the failed CPU and the CPU replaced. If a failure is detected in the backup unit, you can simply remove power from the CPU rack and replace the module.

- Grasp the board firmly at the top and bottom of the board cover with your thumbs on the front of the cover and your fingers on the plastic clips on the back of the cover.
- Squeeze the rack clips on the back of the cover with your fingers to disengage the clip from the rack rail and pull the board firmly to remove it from the back-plane connector.
- Slide the board along the card guide and remove it from the rack.

**96 MHz, 32-Bit Floating Point, 1 MByte Fast Memory
Central Processing Unit for CPU Redundancy Applications**

 GFK-1439C
March 2010
Table 4. References

Reference	Title
1	Programming Software User's Manual
2	Programmable Controller Reference Manual
3	Programmable Controller Installation Manual
4	Hot Standby CPU Redundancy User's Guide

Table 5. Ordering Information

Description	Catalog Number
Central Processing Unit 96 MHz, 32-Bit, Floating Point, 1 Mbyte Fast CMOS RAM Memory for CPU Redundancy applications	IC697CGR935
Redundancy Communications Module	IC697RCM711
Bus Transmitter Module	IC697BEM713
Lithium Battery	IC697ACC701
Rack Fan Assembly, 120 VAC Rack Fan Assembly, 240 VAC Rack Fan Assembly, 24 VDC	IC697ACC721 IC697ACC724 IC697ACC744

Note: For Conformal Coat option, please consult the factory for price and availability.