

GB CONTROL PANEL

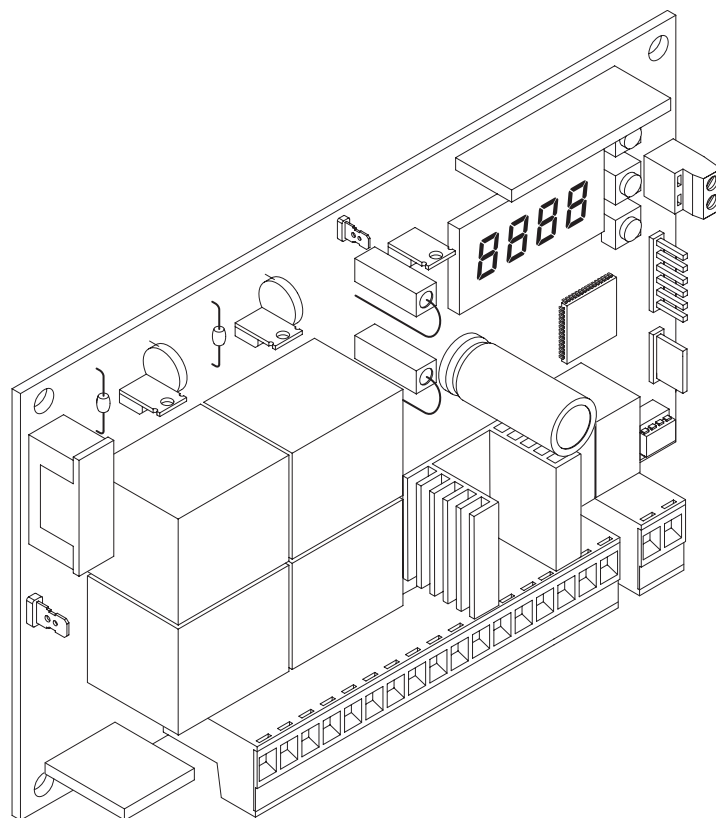

LIBRA-UL-R

INSTALLATION AND USER'S MANUAL

Via Lago di Vico, 44
 36015 Schio (VI)
 Tel.naz. 0445 696511
 Tel.int. +39 0445 696533
 Fax 0445 696522
 Internet: www.bft.it
 E-mail: sales@bft.it

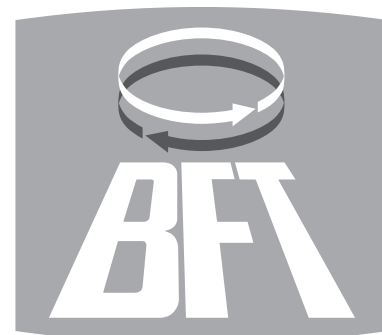

Thank you for buying this product, our company is sure that you will be more than satisfied with its performance.

This product is supplied with an "Instruction Manual" which should be read carefully as it provides important information about safety, installation, operation and maintenance.

1) GENERAL SAFETY

WARNING! An incorrect installation or improper use of the product can cause damage to persons, animals or things.

- The "Warnings" leaflet and "Instruction booklet" supplied with this product should be read carefully as they provide important information about safety, installation, use and maintenance.
- Scrap packing materials (plastic, cardboard, polystyrene etc) according to the provisions set out by current standards. Keep nylon or polystyrene bags out of children's reach.
- Keep the instructions together with the technical brochure for future reference.
- This product was exclusively designed and manufactured for the use specified in the present documentation. Any other use not specified in this documentation could damage the product and be dangerous.
- The Company declines all responsibility for any consequences resulting from improper use of the product, or use which is different from that expected and specified in the present documentation.
- Do not install the product in explosive atmosphere.
- The Company declines all responsibility for any consequences resulting from failure to observe Good Technical Practice when constructing closing structures (door, gates etc.), as well as from any deformation which might occur during use.
- Disconnect the electrical power supply before carrying out any work on the installation. Also disconnect any buffer batteries, if fitted.
- Fit an omnipolar or magnetothermal switch on the mains power supply, having a contact opening distance equal to or greater than 0.13"(3,5 mm).
- Check that a differential switch with a 0.03A threshold is fitted just before the power supply mains.
- Check that earthing is carried out correctly: connect all metal parts for closure (doors, gates etc.) and all system components provided with an earth terminal.
- Fit all the safety devices (photocells, electric edges etc.) which are needed to protect the area from any danger caused by squashing, conveying and shearing.
- Position at least one luminous signal indication device (blinker) where it can be easily seen, and fix a Warning sign to the structure.
- The Company declines all responsibility with respect to the automation safety and correct operation when other manufacturers' components are used.
- Only use original parts for any maintenance or repair operation.
- Do not modify the automation components, unless explicitly authorised by the company.
- Instruct the product user about the control systems provided and the manual opening operation in case of emergency.
- Do not allow persons or children to remain in the automation operation area.
- Keep radio control or other control devices out of children's reach, in order to avoid unintentional automation activation.
- The user must avoid any attempt to carry out work or repair on the automation system, and always request the assistance of qualified personnel.
- Anything which is not expressly provided for in the present instructions, is not allowed.

2) GENERAL OUTLINE

The **LIBRA-UL-R** control panel is supplied by the manufacturer with standard setting. Any alteration must be set by means of the incorporated display programmer or by means of UNIPRO. The Control unit completely supports the EELINK protocol.

Its main characteristics are:

- Control of two low-voltage motors up to 40W power
- Electronic torque setting with obstacle detection
- Limit-switch control inputs
- Separate inputs for safety devices
- Incorporated rolling-code radio receiver with transmitter cloning

The board is provided with a terminal board which can be pulled out for easier maintenance or replacement. The board is supplied with a series of pre-wired jumpers to facilitate the installer's work.

The jumpers relate to the following terminals: 15-17 and 15-18. If the above-mentioned terminals are in use, remove their respective jumpers.

CHECK

The **LIBRA-UL-R** panel carries out a control (check) on the starting relays and safety devices (photocells, safety edge etc.) before carrying out each opening and closing cycle.

In case of malfunction, check the devices connected for regular operation (paragraph 5.6) and check the wiring.



INSTALL THE GATE OPERATOR ONLY WHEN:

- The operator is appropriate for the construction of the gate and the usage Class of the gate,
- All exposed pinch points are eliminated or guarded,
- The operator is intended for installation only on gates used for vehicles. Pedestrians must be supplied with a separate access opening,
- The gate must be installed in a location so that enough clearance is supplied between the gate and adjacent structures when opening and closing to reduce the risk of entrapment. Swinging gates shall not open into public access areas,
- The gate must be properly installed and work freely in both directions prior to the installation of the gate operator. Do not over-tighten the operator clutch or pressure relief valve to compensate for a damaged gate.

FOR GATE OPENERS WITH HOLD-TO-RUN CONTROL:

- The gate operator controls must be placed so that the user has full view of the gate area when the gate is moving,
- A sign with the message "WARNING" must be positioned near the controls. The characters for the writing should be at least 0.25"(6.4 mm) high. The following statement should also be indicated: "Moving Gate Has the Potential of Inflicting Injury or Death - Do Not Start Gate Unless Path is Clear".
- An automatic closing device (such as a timer, loop sensor, or similar device) shall not be employed
- No other activation device shall be connected.

Controls must be far enough from the gate so that the user is prevented from coming in contact with the gate while operating the controls. controls intended to be used to reset an operator after 2 sequential activations of the entrapment protection device or devices must be located in the line-of-sight of the gate. Outdoor or easily accessible controls shall have a security feature to prevent unauthorized use.

All warnings signs and placards must be installed where visible in the area of the gate.

FOR GATE OPERATOR PROVIDED WITH SENSOR FOR CONTACT-FREE DETECTION:

- See instructions on the placement of non contact sensor for each type of application,
- Care shall be exercised to reduce the risk of nuisance tripping, such as when a vehicle, trips the sensor while the gate is still moving, and
- One or more non-contact sensor shall be located where the risk of entrapment or obstruction exist, such as the perimeter reachable by a moving gate or barrier.

FOR GATE OPERATOR PROVIDED WITH CONTACT DETECTION (RUBBER EDGE OR SIMILAR):

- On or more contact sensor shall be located at the pinch point of a vehicular vertical pivot gate.
- A hardwired contact sensor shall be located and its wiring arranged so that the communication between the sensor and the gate operator is not subjected to mechanical damage.
- A wireless contact sensor such as one that transmits radio frequency (RF) signals the gate operator for entrapment protection functions shall be located where the transmission of the signals are not obstructed or impeded by building structure, natural landscaping or similar obstruction. A wireless contact sensor shall function under the intended end-use conditions.



IMPORTANT SAFETY INSTRUCTIONS

WARNINGS: to reduce the risk of injury or death:

- **Read and follow all instructions.**
- Never let children operate or play with gate control. Keep the remote control away from children.
- Always keep people and objects away from the gate. **NO ONE SHOULD CROSS THE PATH OF THE MOVING GATE.**
- All openings of a horizontal slide gate are guarded or screened from the bottom of the gate to a minimum of 4 feet (1.22 m) above the ground to prevent a 2-1/4 inch (57.2 mm) diameter sphere from passing through the openings anywhere in the gate, and in that portion of the adjacent fence that the gate covers in the open position,
- All exposed pinch points are eliminated or guarded, and guarding is supplied for sliding gates exposed rollers.

3) TECHNICAL DATA

Power supply:120Va.c. ±10% 60Hz*
 Mains/low voltage insulation: > 2MΩ 500Vdc
 Working temperature: from 14°F to 131° F (-10 to +55°C)
 Dielectric strength:..... mains/low voltage 3750Vac per 1 minute
 Motor output current:3.5A+3.5A max
 Motor relay commutation current: 10A
 Maximum motor power:..... 40W (24Vd.c.)
 Supply to accessories: 24Va.c. (180mA max absorption)
 24Va.c. V safe (180mA max absorption)
 Gate-open warning light: N.O. contact (24Va.c./1A max)
 Blinker: 24Va.c. 25W max
 Dimensions:see figure 1
 Fuses: JP1=2 AT, F2=1,25 AT
 (* other voltages available on request)

BATTERY KIT BT BAT (Fig.6)

Charging voltage:..... 27.2Vdc
 Charging current:..... 130mA
 Outside temperature when values were measured: 25°C
 Battery capacity:..... 2x (12V 1.2Ah)
 Flat battery protection threshold:..... 20.4Vd.c.
 Battery charging time:..... 12/14 hrs
 NOTE: In case of operation with battery back up, the outputs to terminals 11-12 (24 Va.c.) and 13-14 (Vsafe 24 Va.c.) have a voltage of 24 Vd.c., polarised as shown in Fig. 6.
 When installing the BT-BAT kit, check for correct connection of the safety devices.

4) TERMINAL BOARD CONNECTIONS (Fig.3)

WARNING! Mount the LIBRA-UL-R control panel with 4 screws making sure not to alter the degree of protection against water entry.

For the electrical installation are the “Canadian Electrical Code PART I” for Canada and the “National Electrical Code (NFPA 70)” for the United States.

WARNING – During the wiring and installation operations, refer to the current standards as well as principles of good technical practice.

Wires powered at different voltages must be physically separated, or suitably insulated with at least 0.04”(1 mm) extra insulation. The wires must be clamped by an extra fastener near the terminals, for example by bands.

All the connection cables must be kept at an adequate distance from the dissipator.

WARNING! For connection to the mains power supply (120V, 60Hz), permanent wiring is to be employed as required by local codes. Supply conductors (120V, 60Hz) and the main ground conductor should be contained in approved flexible watertight conduit and be at least size N.16 AWG.

Ground Terminal: make sure the main ground conductor is connected to the ground terminal (See Fig.3).

JP1
 1-2 Single-phase mains power supply 120Va.c. ±10% (1=L) (2=N)

JP2-JP5
 Connection to the secondary of the transformer.

JP9
 3-4-5 Connection to motor 2:
 3 motor + (green)
 4 motor - (black),
 5 limit-switch control (white)

6-7-8 Connection to motor 1:
 6 motor + (green)
 7 motor - (black)
 8 limit-switch control (white)

9-10 Connection to blinker (24Va.c. 20W max)
JP8
 11-12 Output 24Va.c. 180mA max - supply to photocells or other devices
 13-14 Output 24Va.c. V safe 180mA max - supply to photocell transmitters with checking function (Fig.3a).

15-16 START pushbutton (N.O.).
 15-17 (5tRrE - cLσ5E) OFF. START pushbutton (N.O.)
 (5tRrE - cLσ5E) ON. CLOSE pushbutton (N.O.)

15-18 Photocell input (N.C.). If not used, leave the bridge 15-18 connected.

15-19 Fault input (N.O.). Input for photocells provided with checking N.O. contact (Fig. 3a).

15-20 OPEN pushbutton (N.O.)
JP7
 21-22 Acoustic signal contact (N.O.) (Fig. 3a).
 23-24 Antenna input for radio-receiver plug-in board (23 signal–24 braid).

5) PROGRAMMING

The control panel provided with a microprocessor is supplied with function parameters preset by the manufacturer, suitable for standard installations. The predefined parameters can be altered by means of either the incorporated display programmer or UNIPRO.

In the case where programming is carried out by means of UNIPRO, carefully read the instructions relating to UNIPRO, and proceed in the following way.

Connect the UNIPRO programmer to the control unit through the UNIFLAT and UNIDA accessories (See fig. 4). The **LIBRA-UL-R** control unit does not supply the UNIPRO programmer with power, and therefore requires an appropriate supply unit.

Enter the “CONTROL UNITS” menu, and the “PARAMETERS” submenu, then scroll the display screenfuls using the up/down arrows to set the numerical values of the parameters listed below.

For the function logics, refer to the “LOGIC” submenu.

In the case where programming is carried out by means of the incorporated programmer, refer to Fig. A and B and to the paragraph on “Configuration”.

6) CONFIGURATION

The display programmer is used to set all the **LIBRA-UL-R** control panel functions.

The programmer is provided with three pushbuttons for menu scrolling and function parameter configuration:

- + menu scrolling/value increment key
- menu scrolling/value reduction key

OK Enter (confirm) key

The simultaneous pressure of the + and - keys is used to exit the active menu and move to the preceding menu.

The modifications made are only set if the OK key is subsequently pressed. When the OK key is pressed for the first time, the programming mode is entered.

The following pieces of information appear on the display at first:

- Control unit software version
- Number of total manoeuvres carried out (the value is expressed in thousands, therefore the display constantly shows 0000 during the first thousand manoeuvres)
- Number of manoeuvres carried out since the latest maintenance operation (the value is expressed in thousands, therefore the display constantly shows 0000 during the first thousand manoeuvres)
- Number of memorised radio control devices.

When the OK key is pressed during the initial presentation phase, the first menu can be accessed directly.

Here follows a list of the main menus and the respective submenus available. The predefined parameter is shown between square brackets [0].

The writing appearing on the display is indicated between round brackets. Refer to Figures A and B for the configuration procedure.

6.1) PARAMETER MENU (PR-RP)

- **Automatic Closing Time (tCR) [10s]**
 Set the numerical value of the automatic closing time from 3 to 60 seconds.
- **Motor 1 torque (Pσt 1 tσr 9UE) [50%]**
 (UNIPRO ⇒ Advanced parameters ⇒ address 3)
 Set the numerical value of the motor 1 torque between 1% and 99%.
- **Motor 2 torque (Pσt 2 tσr 9UE) [50%]**
 (UNIPRO ⇒ Advanced parameters ⇒ address 4)
 Set the numerical value of the motor 2 torque between 1% and 99%.
- **Motor 1 slow-down torque (P 1 t 5LσL) [45%]**
 (UNIPRO ⇒ Advanced parameters ⇒ address 8)
 Set the numerical value for slow-down torque of motor 1 between 1% and 99%.
- **Motor 2 slow-down torque (P 2 t 5LσL) [45%]**
 (UNIPRO ⇒ Advanced parameters ⇒ address 9)
 Set the numerical value for slow-down torque of motor 2 between 1% and 99%.

NOTE: In case of obstacle detection, the Ampere-stop function halts the leaf movement, reverses its motion for 1 sec. and then halts in the STOP status.

 **Incorrect sensitivity setting can cause injuries to persons or animals, or damage to things.**

- **Opening delay time (σPER dELRY t IPE) [1s]**
 Set the opening delay time for motor 1 relative to motor 2, between 1 and 10 seconds.
- **Closing delay time (cL5 dELRY t IPE) [1s]**
 Set the closing delay time for motor 2 relative to motor 1, between 1 and 10 seconds.

- **Motor 1 Normal Speed Time** ($F1\ FR5t\ t\ iPE$) [15s]
(UNIPRO fi Advanced parameters fi address 6)
Set the time to normal speed (not slowed down), ranging from 1 to 30 seconds.
- **Motor 2 Normal Speed Time** ($F2\ FR5t\ t\ iPE$) [15s]
(UNIPRO \Rightarrow Advanced parameters \Rightarrow address 7)
Set the time to normal speed (not slowed down), ranging from 1 to 30 seconds.
Note: The slow-down time, on closing and on opening, is obtained by timing one manoeuvre and setting a minimum value for this parameter. If, for example, one manoeuvre lasts 25 seconds, a setting of "normal speed time" to 20s will produce a slow-down time of 5s both on closing and on opening.
- **Slow-down speed** ($5L\ ou\ SPEEd$) [0]
(UNIPRO \Rightarrow Advanced parameters \Rightarrow address 5)
Set the slow-down speed by choosing from the following values:
0 – slow-down disabled
1 – slow-down to 50% of normal speed
2 – slow-down to 33% of normal speed
3 – slow-down to 25% of normal speed
- **Zone** ($ZonE$) [0]
Set the zone number between a minimum value of 0 and a maximum value of 127. See paragraph 7 on "Serial connection".

6.2) LOGIC MENU ($L\ og\ ic$)

- **TCA** ($t\ cR$) [OFF]
ON Activates automatic closing
OFF Excludes automatic closing
- **3 Steps** ($3\ 5tEP$) [OFF]
ON Enables 3-step logic. A Start impulse has the following effects:
door closed:.....opens
on opening:.....stops and enters TCA (if configured)
door open:closes
on closing:.....stops and reopens
OFF Enables 4-step logic. A Start impulse has the following effects:
door closed:.....opens
on opening:.....stops and enters TCA (if configured)
door open:closes
on closing:.....stops and does not enter TCA (stop)
after stopping:.....opens
- **Impulse lock** ($ibL\ oPEN$) [OFF]
ON The Start impulse has no effect during the opening phase.
OFF The Start impulse becomes effective during the opening or closing phase.
- **Rapid closing** ($FR5t\ cL5$) [OFF]
ON Closes the gate after photocell disengagement, before waiting for the end of the TCA set.
OFF Command not entered.
- **Photocells on opening** ($Pho\ t\ c. oPEN$) [OFF]
(UNIPRO \Rightarrow Advanced logics \Rightarrow address 14)
ON: In case of obscuring, this excludes photocell operation on opening. During the closing phase, it immediately reverses the motion.
OFF: In case of obscuring, the photocells are active both on opening and on closing. When a photocell is obscured on closing, it reverses the motion only after the photocell is disengaged.
- **Photocell test** ($tE5t\ Pho\ t$) [OFF]
ON Activates photocell check
OFF Deactivates photocell check
If this setting is not activated (OFF), it inhibits the photocell checking function, allowing connection of devices not provided with additional checking contact.
- **Motors in operation** ($i\ P\ o\ t\ on$) [OFF]
ON Only motor 2 is in operation (terminals 3, 4 and 5).
With this configuration, the pedestrian input is disabled.
OFF Both motors are in operation.
- **Lock hold** ($bL\ o\ c\ H\ PE-5\ i5t$) [OFF] (Fig. 5)
ON To be used when the mechanical closing backstop is fitted.
This function activates leaf pressure on the mechanical backstop, without this being considered as an obstacle by the Ampere-stop sensor. Therefore the rod continues its travel for another 0.5 sec. after detecting the closing limit switch or upon reaching the mechanical backstop. So by activating the closing limit switches slightly earlier, the leaves will come to a perfect halt against the backstop.(Fig.5a)
OFF To be used when no mechanical closing backstop is fitted.
Movement is exclusively halted by activation of the closing limit switches; in this case proceed to carrying out precise setting of the closing limit-switch activation. (Fig. 5b)
- **Start-Close selection** ($5tPRt\ t\ -\ cL\ o5E$) [OFF]
ON The input between the two terminals 15-16 acts as close
OFF The input between the two terminals 15-16 acts as start
- **Fixed code** ($F\ iHEd\ codE$) [OFF]
(UNIPRO \Rightarrow Advanced logics \Rightarrow address 13)

- ON The receiver is configured for operation in fixed-code mode, see paragraph on "Radio Transmitter Cloning".
- OFF The receiver is configured for operation in rolling-code mode, see paragraph on "Radio Transmitter Cloning".
- **Radio transmitter programming** ($rRd\ io\ P\ r\ o\ G$) [ON]
(UNIPRO \Rightarrow Advanced logics \Rightarrow address 15)
ON This enables transmitter storage via radio:
1 – First press the hidden key (P1) and then the normal key (T1, T2, T3 or T4) of a transmitter already memorised in standard mode by means of the radio menu.
2 – Within 10s press the hidden key (P1) and the normal key (T1, T2, T3 or T4) of a transmitter to be memorised.
The receiver exits the programming mode after 10s, other new transmitters can be entered before the end of this time.
This mode does not require access to the control panel.
OFF This disables transmitter storage via radio.
The transmitters can only be memorised using the appropriate Radio menu.
- **Master/Slave** ($F\ R5tEr$) [OFF]
ON The control panel is set as Master in a centralised connection (see Paragraph 7).
OFF The control panel is set as Slave in a centralised connection (see Paragraph 7).

6.3) RADIO MENU ($rRd\ io$)

- **Add**
Allows you to add one key of a radio control device to the receiver memory; after storage it displays a message showing the receiver number in the memory location (from 01 to 64).
- **Add Start button** ($Rdd\ 5tPRt$)
associates the required key to Start command
- **Read** ($rERd$)
Checks one key of a receiver; if stored it displays a message showing the receiver number in the memory location (from 01 to 64), and the key number (T1, T2, T3 or T4).
- **Eliminate list** ($ErER5E\ 54$)
WARNING! Completely removes all memorised radio control devices from the receiver memory.
- **Receiver code reading** (RX code)
This displays the code entered in the receiver (par. 11).
Consult paragraphs 9/10/11 and 12 for further information concerning the advanced functions of the Clonix incorporated receiver.

6.4) LANGUAGE MENU ($L\ R\ n\ G\ U\ R\ G\ E$)

Allows you to set the language on the display programmer.

- **ITALIAN** ($i\ tR$)
- **FRENCH** ($F\ rR$)
- **ENGLISH** ($E\ nG$)
- **SPANISH** ($E5P$)

6.5) DEFAULT MENU ($dEFRAUt$)

Restores the preset default values on the control unit. After restoring, a new autoselection operation must be carried out.

6.6) DIAGNOSTICS AND MONITORING

The display on the LIBRA-UL-R panel shows some useful information, both during normal operation and in the case of malfunctions.

Diagnostics:

In the case of malfunctions, the display shows a message indicating which device needs to be checked:

STRT = START input activation

STOP = STOP input activation

PHOT = PHOT input activation

FLT = FAULT input activation for checked photocells

In the case where an obstacle is found, the LIBRA-UL-R panel stops the door and activates a reverse manoeuvre; at the same time the display shows the "AMP" message.

Monitoring:

During the opening and closing phases, the display shows four digits separated by a dot, for example 35.40. The digits are constantly updated during the manoeuvre, and represent the maximum torque reached by motor 1 (35) and motor 2 (40).

These values allow the torque setting to be corrected.

If the maximum torque value reached during the manoeuvre gets sensibly close to the value set in the parameter menu, malfunctions may occur in the future following wear or slight door deformation.

It is therefore advisable to check the maximum torque reached during some

of the manoeuvres carried out in the course of installation, and if necessary set a value about 15-20 percent points higher in the parameter menu.

6.7) AUTOSSET MENU (RiUt-o5Et)

Allows you to automatically set the Motor torque.

WARNING!! The autosest operation is only to be carried out after checking the exact leaf (opening/closing) movement, and correct limit-switch activation. As soon as the OK pushbutton is pressed, the "....." message is displayed, and the control unit executes an opening manoeuvre followed by a closing manoeuvre, during which the minimum torque value needed for leaf movement is automatically set.

During this phase, it is important to avoid obscuring the photocells, as well as using the START, STOP or OPEN commands and the display.

After this, if autosesting has been successfully completed, the control unit displays the "OK" message and, after pressing any key, returns to the Autosest menu.

If, on the other hand, the control unit displays the "KO" message, it means that the autosest procedure has not been successfully completed; it is thus necessary to check the wear condition of the gate and the regular movement of the leaves before proceeding to a new autosest operation.

WARNING! During the autosest phase, the obstacle detection function is not active, therefore the installer must control the automation movement and prevent persons and things from approaching or standing within the automation working range.

In the case where buffer batteries are used, autosesting must be carried out with the control panel supplied by mains power voltage.

 **Incorrect sensitivity setting can cause injuries to persons or animals, or damage to things.**

7) STATISTICS

Having connected the UNIPRO programmer to the control unit, enter the CONTROL UNIT / STATISTICS menu and scroll the screenful showing the statistical parameters:

- Board microprocessor software version.
- Number of cycles carried out. If motors are replaced, count the number of manoeuvres carried out up to that time.
- Number of cycles carried out from the latest maintenance operation. It is automatically set to zero after each self-diagnosis or parameter writing.
- Date of latest maintenance operation. To be updated manually from the appropriate menu "Update maintenance date".
- Installation description. 16 characters can be entered for installation identification.

8) ALARM SIGNAL

The operator is provided with an alarm siren managed from the control panel.

The alarm signal is set off in the case where the obstacle detection device (amperostop) is activated twice, without in leaves being brought to its fully opened or closed position.

In the case of malfunctions, any alarm activation immediately stops all manoeuvres.

The acoustic signal can be interrupted using the STOP button.

In the case of alarm activation check that the gates has not met any obstacles.

9) INTEGRATED RECEIVER TECHNICAL SPECIFICATION

Receiver output channels:

- output channel 1, if activated, controls a START command.

Transmitter versions which can be used:



all Rolling Code transmitters compatible with

ANTENNA INSTALLATION

Use an antenna tuned to 433MHz.

For Antenna-Receiver connection, use RG8 coaxial cable.

The presence of metallic masses next to the antenna can interfere with radio reception. In case of insufficient transmitter range, move the antenna to a more suitable position.

10) RECEIVER CONFIGURATION

The on-board receiver combines characteristics of utmost safety in copying variable code (rolling code) coding with the convenience of carrying out transmitter "cloning" operations thanks to an exclusive system.

Cloning a transmitter means creating a transmitter which can be automatically included within the list of the transmitters memorised in the receiver, either as an addition or as a replacement of a particular transmitter.

Cloning by replacement is used to create a new transmitter which takes the place of the one previously memorised in the receiver; in this way a specific transmitter can be removed from the memory and will no longer be usable.

Therefore it will be possible to remotely program a large number of additional transmitters or, for example, replacement transmitters for those which have been lost, without making changes directly to the receiver.

When coding safety is not a decisive factor, the on-board receiver allows you to carry out fixed-code additional cloning which, although abandoning the variable code, provides a high number of coding combinations, therefore keeping it possible to "copy" any transmitter which has already been programmed.

PROGRAMMING

Transmitter storage can be carried out in manual mode or by means of the UNIRADIO programmer which allows the complete installation database to be managed through the **EEdbase** software.

In this second case, receiver programming takes place through the connection of UNIRADIO to the **LIBRA-UL-R** control panel, using the UNIFLAT and UNIDA accessories as indicated in Fig. 4.

11) MANUAL PROGRAMMING

In the case of standard installations where advanced functions are not required, you can proceed to manual storage of the transmitters, making reference to fig. B for basic programming.

- If you wish the transmitter to activate output 1 (START) by means of key1, key2, key3 or key4, enter the transmitter in menu "Start key", as in fig. B.

Note: Hidden key P1 appears differently depending on the transmitter model.

For transmitters with hidden key, press hidden key P1 (fig. B1). For transmitters without hidden key, the key P1 function corresponds to simultaneously pressing the 4 transmitter keys or, after opening the battery compartment, bridging the two P1 points by means of a screwdriver (fig. B2).

IMPORTANT NOTE: ATTACH THE ADHESIVE KEY LABEL TO THE FIRST MEMORISED TRANSMITTER (MASTER).

In the case of manual programming, the first transmitter assigns the key code to the receiver; this code is necessary in order to carry out subsequent cloning of the radio transmitters.

12) RADIO-TRANSMITTER CLONING

Rolling-code cloning / Fixed-code cloning

Make reference to the UNIRADIO Instructions and the CLONIX Programming Guide.

12.1) ADVANCED PROGRAMMING: COLLECTIVE RECEIVERS

Make reference to the UNIRADIO Instructions and the CLONIX Programming Guide.

13) SCRAPPING

Warning: This operation should only be carried out by qualified personnel. Materials must be disposed of in conformity with the current regulations. In case of scrapping, the automation devices do not entail any particular risks or danger. In case of materials to be recycled, these should be sorted out by type (electrical components, copper, aluminium, plastic etc.).

14) DISMANTLING

Warning: This operation should only be carried out by qualified personnel. When the control unit is disassembled to be reassembled on another site, proceed as follows:

- Disconnect the power supply and the entire electrical installation.
- In the case where some of the components cannot be removed or are damaged, they must be replaced.

The descriptions and illustrations contained in the present manual are not binding. The Company reserves the right to make any alterations deemed appropriate for the technical, manufacturing and commercial improvement of the product, while leaving the essential product features unchanged, at any time and without undertaking to update the present publication.

Fig. A

DB11394_06

LEGENDA

[00] Preset value

↑ +/ON / **↓ -/OFF** Parameter increment/reduction or ON/OFF commutation

OK Press OK key (Enter/confirm)

↓ ↑ + Menu scrolling (+ = preceding - = following)

+/- Simultaneously press the + and - keys. Simultaneous pressure of the + and - keys allows you to exit the active menu and return to the preceding menu; if this takes place at the main menu level, programming is exited and the display switched off.

The modifications made are only confirmed if the OK key is subsequently pressed.

PrG Message: Programming in progress

Ko Message: KO! (value or function error)

-ξ Message: "Wait" (enter value or function)

ACCESS TO MENUS

Press the OK key

OK → **bFt** Control unit software version

OK → **L br R 10** No. total manoeuvres (in thousands)

OK → **0000** No. manoeuvres since latest maintenance (in thousands)

OK → **00** No. radio control devices memorised

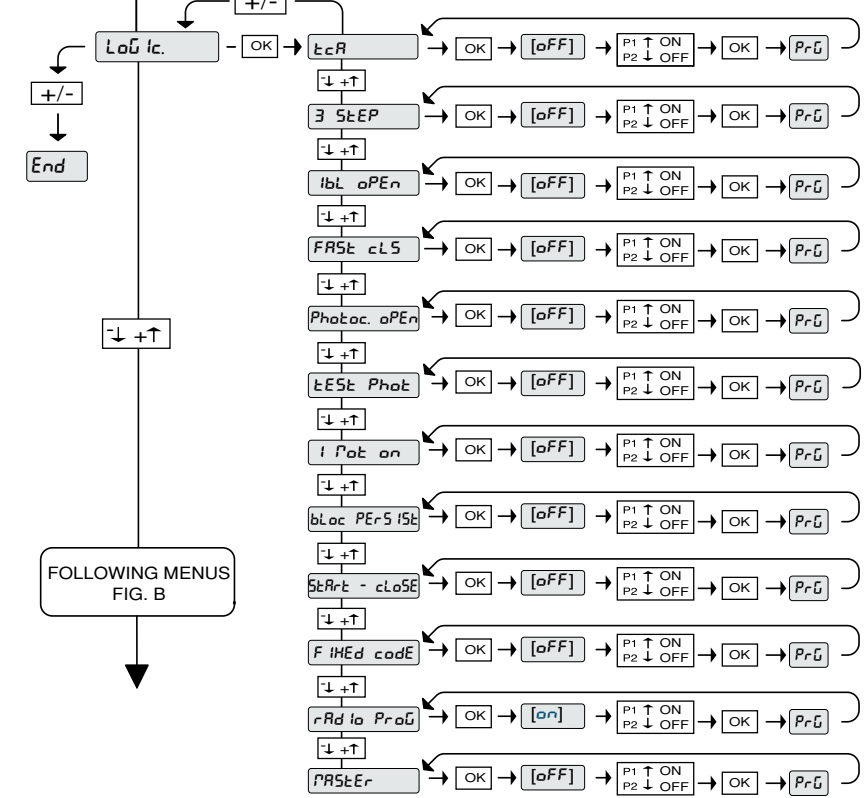
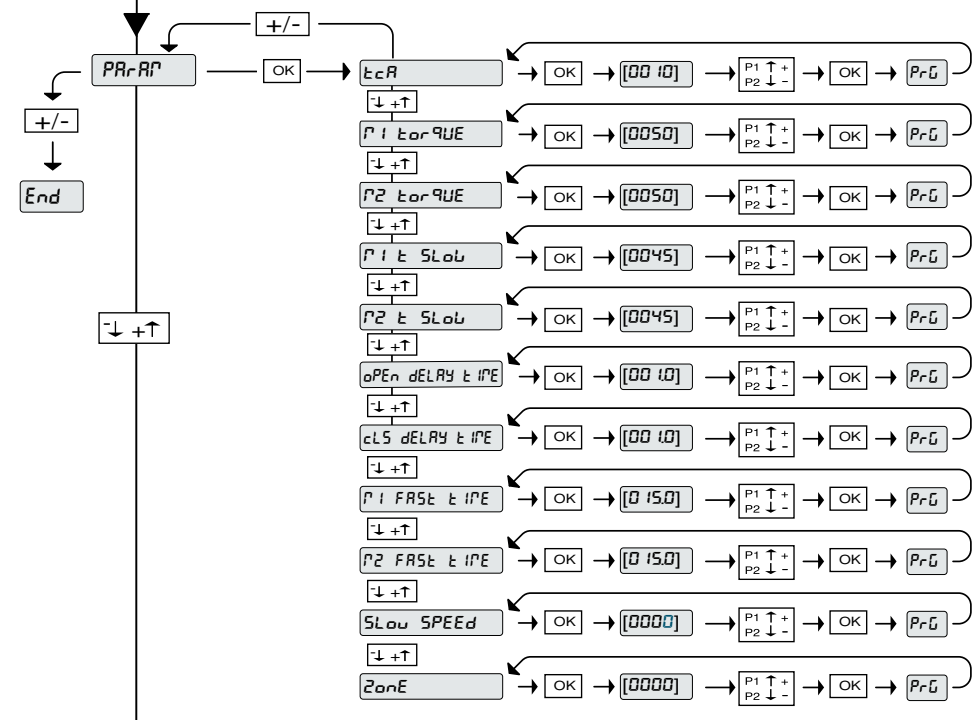

PARAMETER MENU

- TCA** (automatic closing time)
value expressed in seconds
(default 10=10s, min 3=3s, max 60=60s)
- Motor 1 torque** value expressed in %
(default 50%, min 1%, max 99%)
- Motor 2 torque** value expressed in %
(default 50%, min 1%, max 99%)
- Motor 1 torque slow-down**
value expressed in %
(default 45%, min 1%, max 99%)
- Motor 2 torque slow-down**
value expressed in %
(default 45%, min 1%, max 99%)
- Opening delay time**
value expressed in tenths of a second
(default 10=1s, min 10=1s, max 100=10s)
- Closing delay Time**
value expressed in tenths of a second
(default 10=1s, min 10=1s, max 10=10s)
- Motor 1 Normal speed time**
value expressed in seconds
(default 15=15s, min 1=1s, max 30=30s)
- Motor 2 Normal speed time**
value expressed in seconds
(default 15=15s, min 1=1s, max 30=30s)
- Slow-down speed**
0= Slow-down disabled
1= 50% of normal speed
2= 33% of normal speed
3= 25% of normal speed
- Zone** numerical value
(default 0, min 0, max 127)

Fig. B

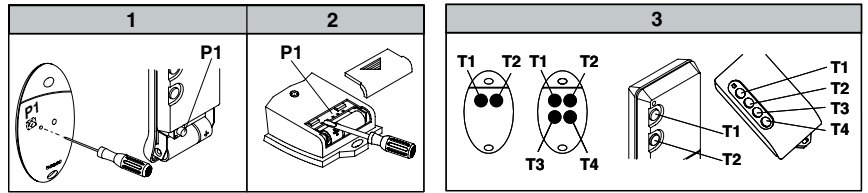

PRECEDING MENUS
FIG. A

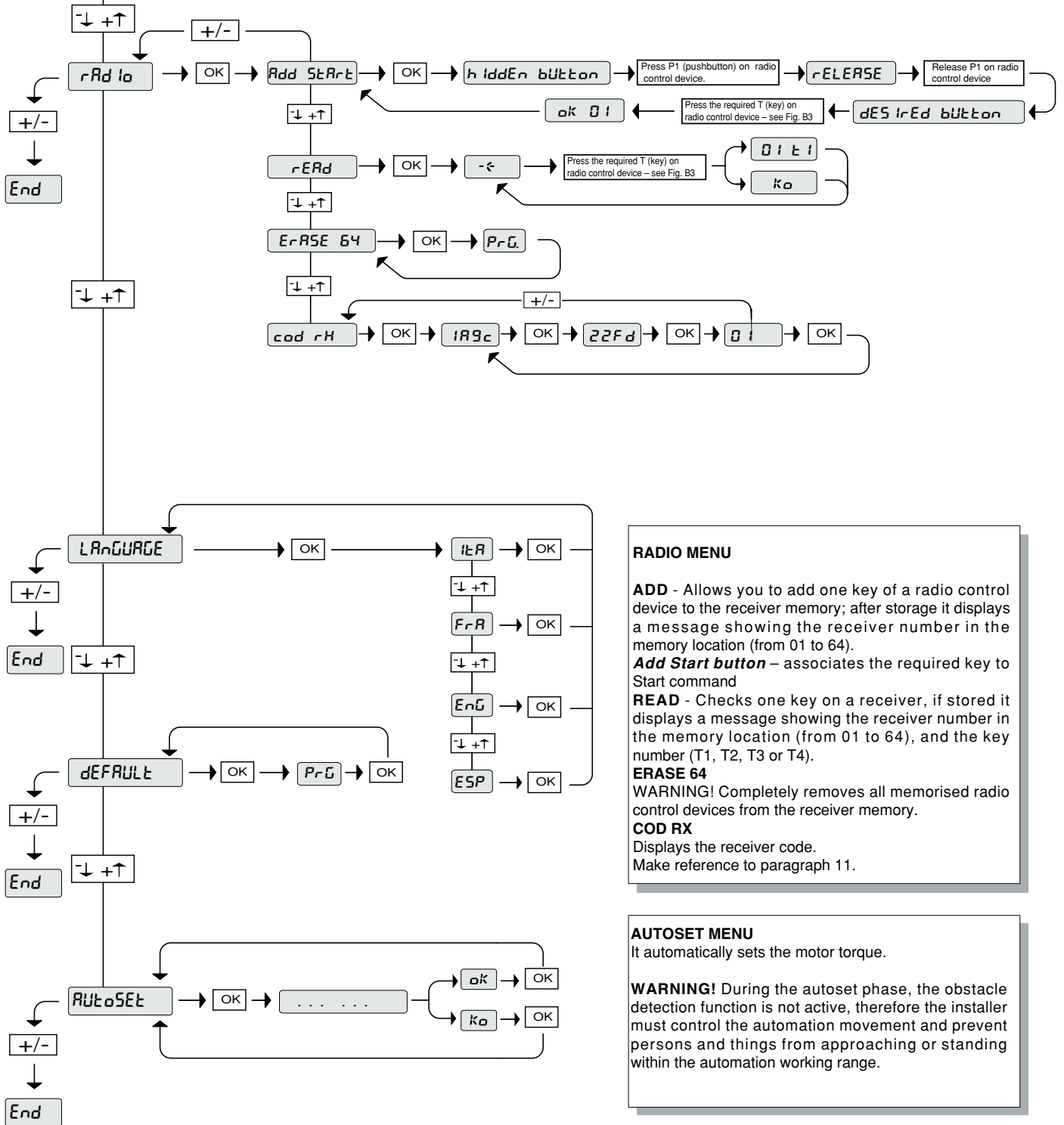

RADIO MENU

ADD - Allows you to add one key of a radio control device to the receiver memory; after storage it displays a message showing the receiver number in the memory location (from 01 to 64).

Add Start button – associates the required key to Start command

READ - Checks one key on a receiver, if stored it displays a message showing the receiver number in the memory location (from 01 to 64), and the key number (T1, T2, T3 or T4).

ERASE 64

WARNING! Completely removes all memorised radio control devices from the receiver memory.

COD RX

Displays the receiver code.
Make reference to paragraph 11.

AUTOSET MENU

It automatically sets the motor torque.

WARNING! During the autaset phase, the obstacle detection function is not active, therefore the installer must control the automation movement and prevent persons and things from approaching or standing within the automation working range.

Fig. 1

CAUTION! Drill a hole paying attention not to damage the board components. Use a drill that allows for the depth dimension to be checked. The hole depth (drill length) must not exceed 0.4" (10 mm).
CAUTION! Drill a 0.11"(3 mm). hole on the box to allow air circulation. The drilling position depends on the installation position and on the environment where the box will be installed. Pay attention not to alter the degree of protection from water.
 The position of the hole in Fig. 1 is merely indicative.

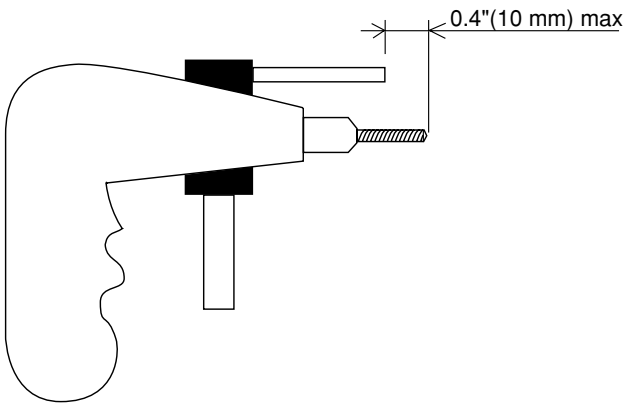
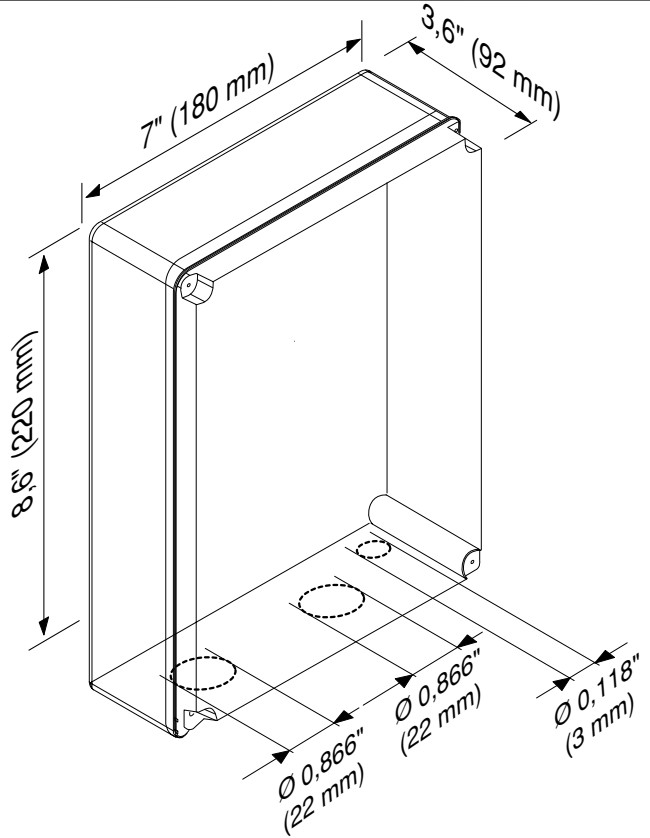

CAUTION! To guarantee the proper sealing of the box, it is necessary to use adequate cable glanding or strain relief cord connectors.

Fig. 2

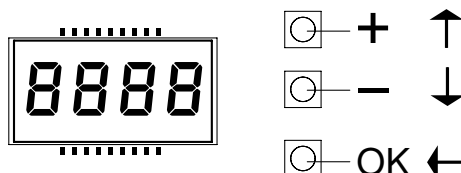
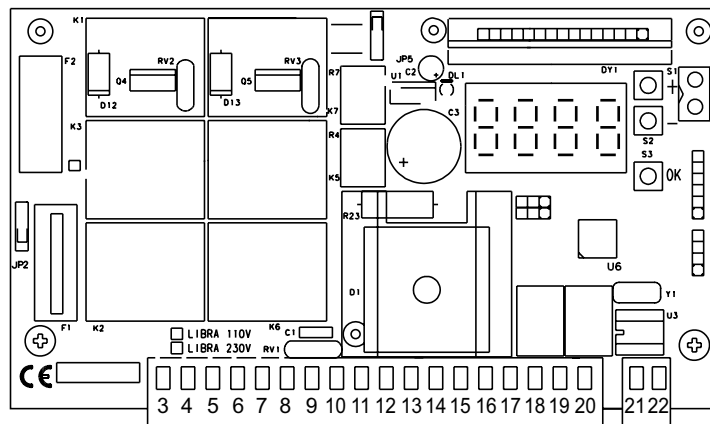

Fig. 3

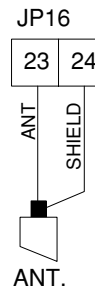
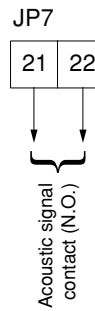
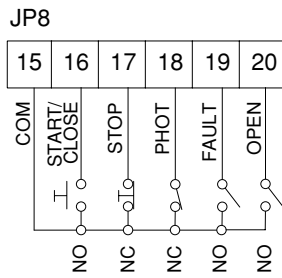
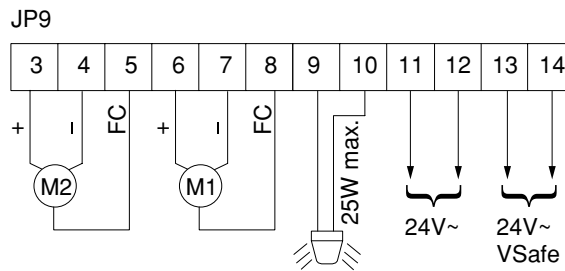
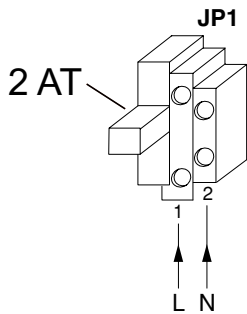
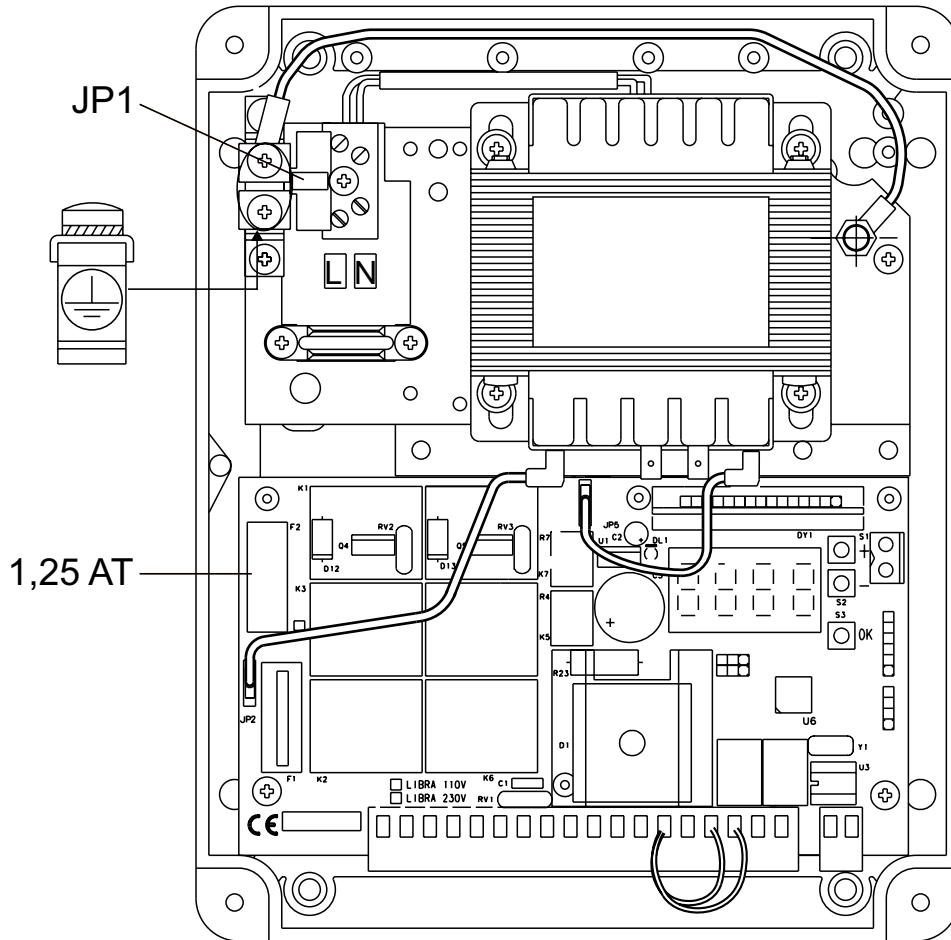

Fig. 3a

D811394_06

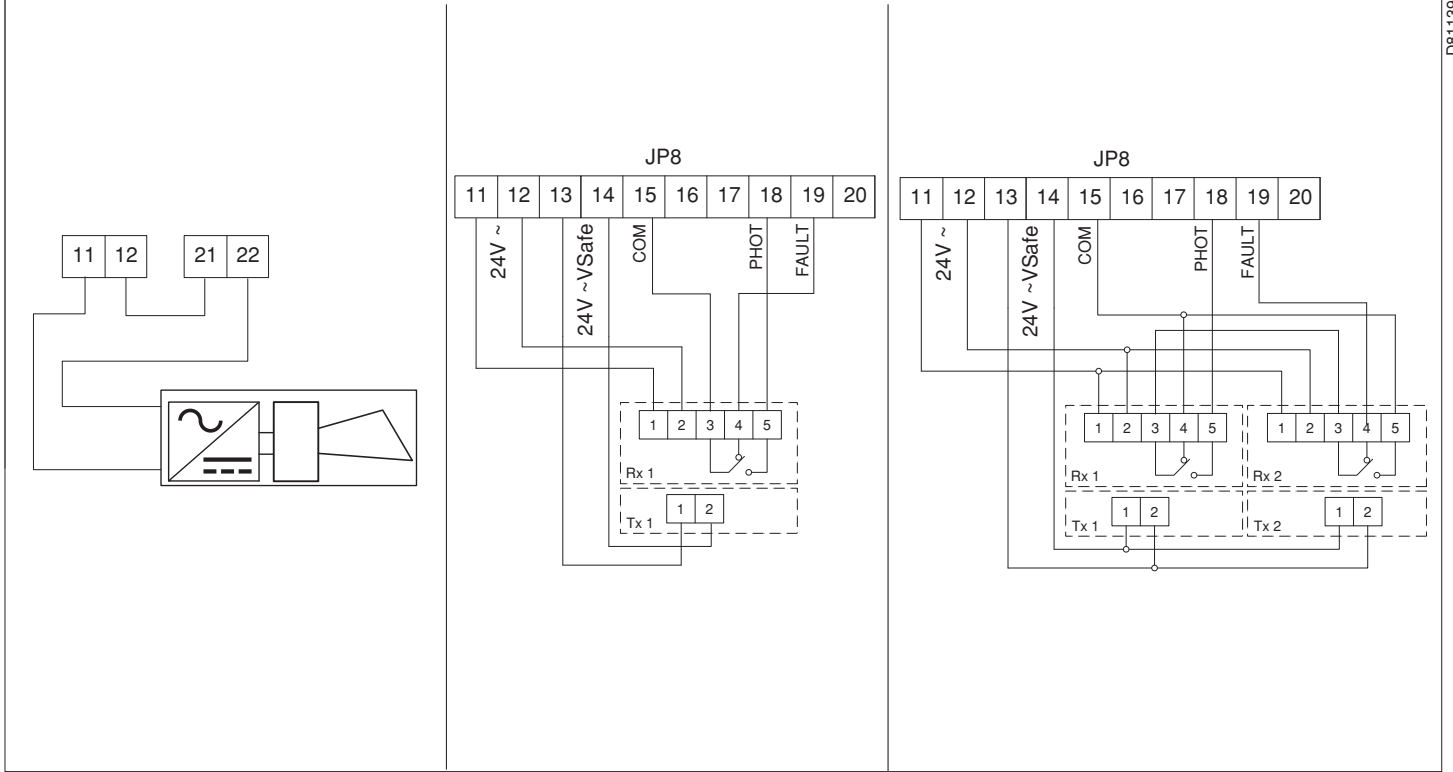

Fig. 4

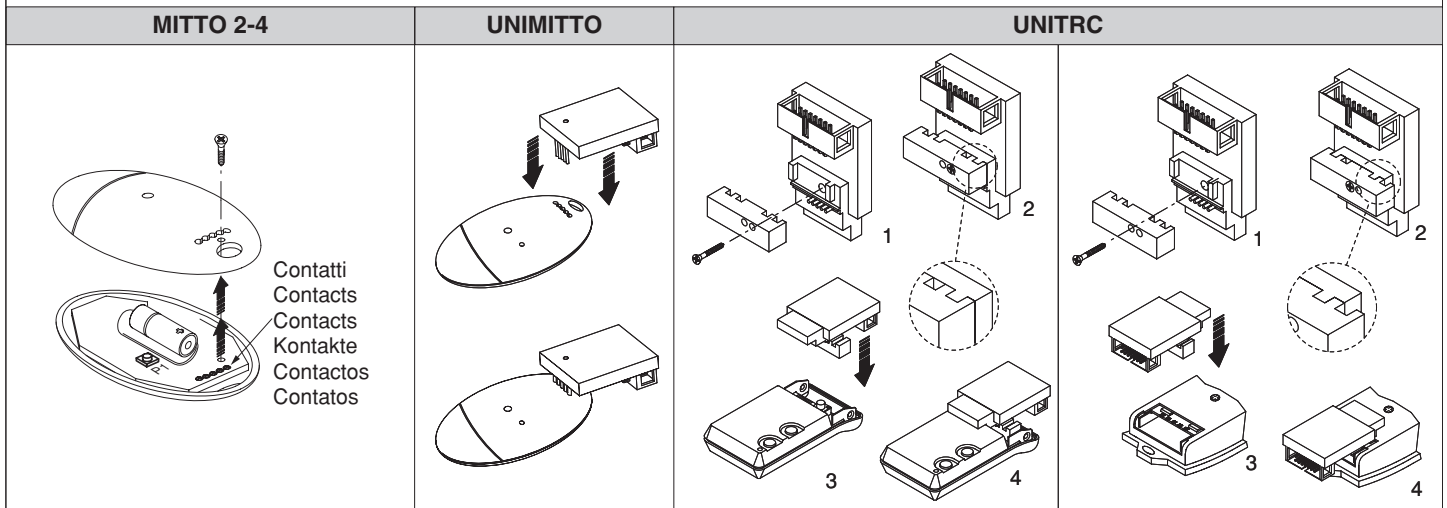
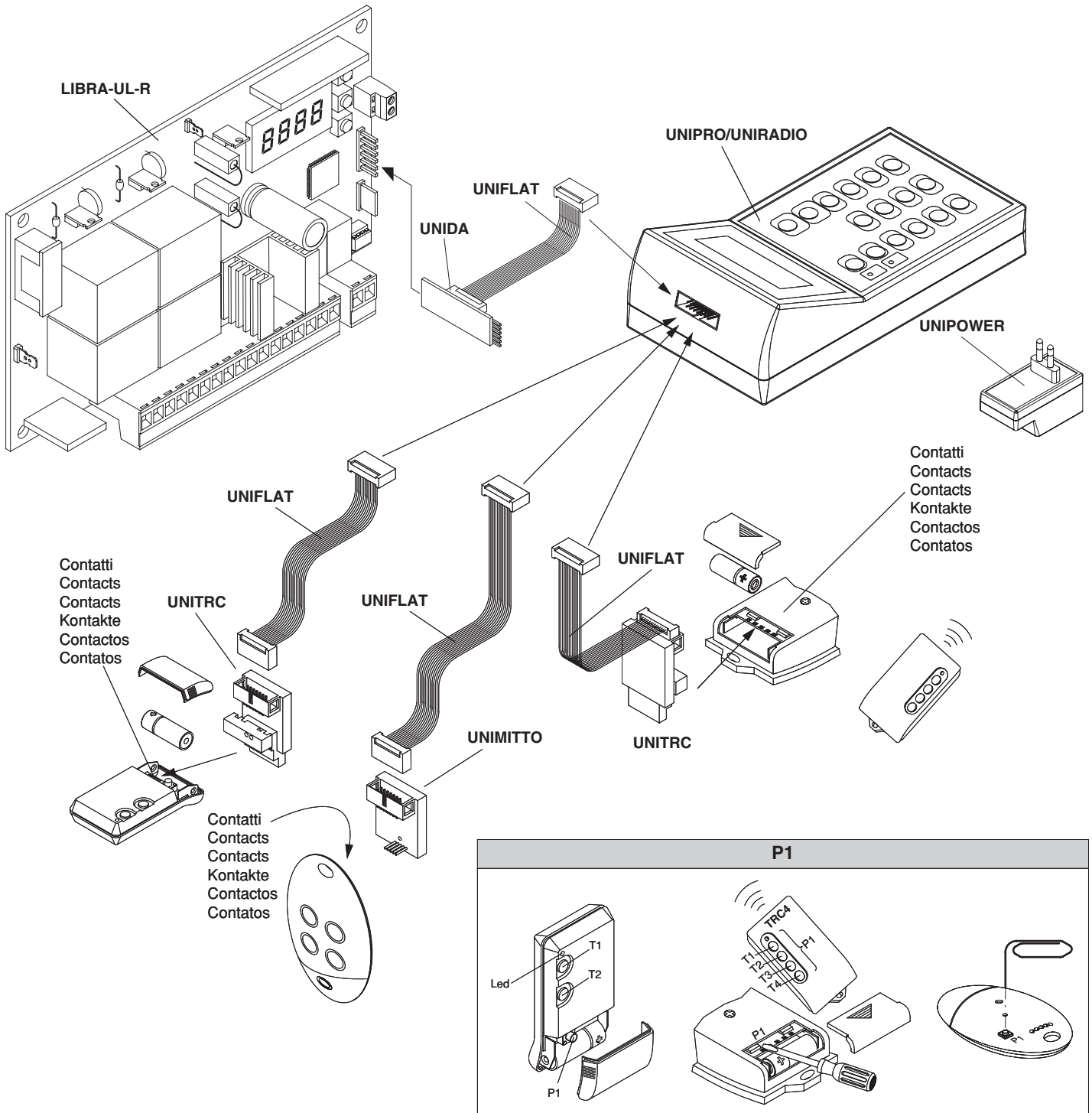

Fig. 5

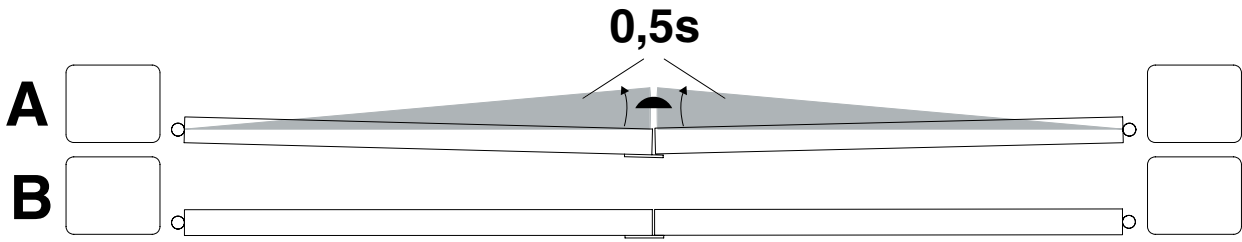
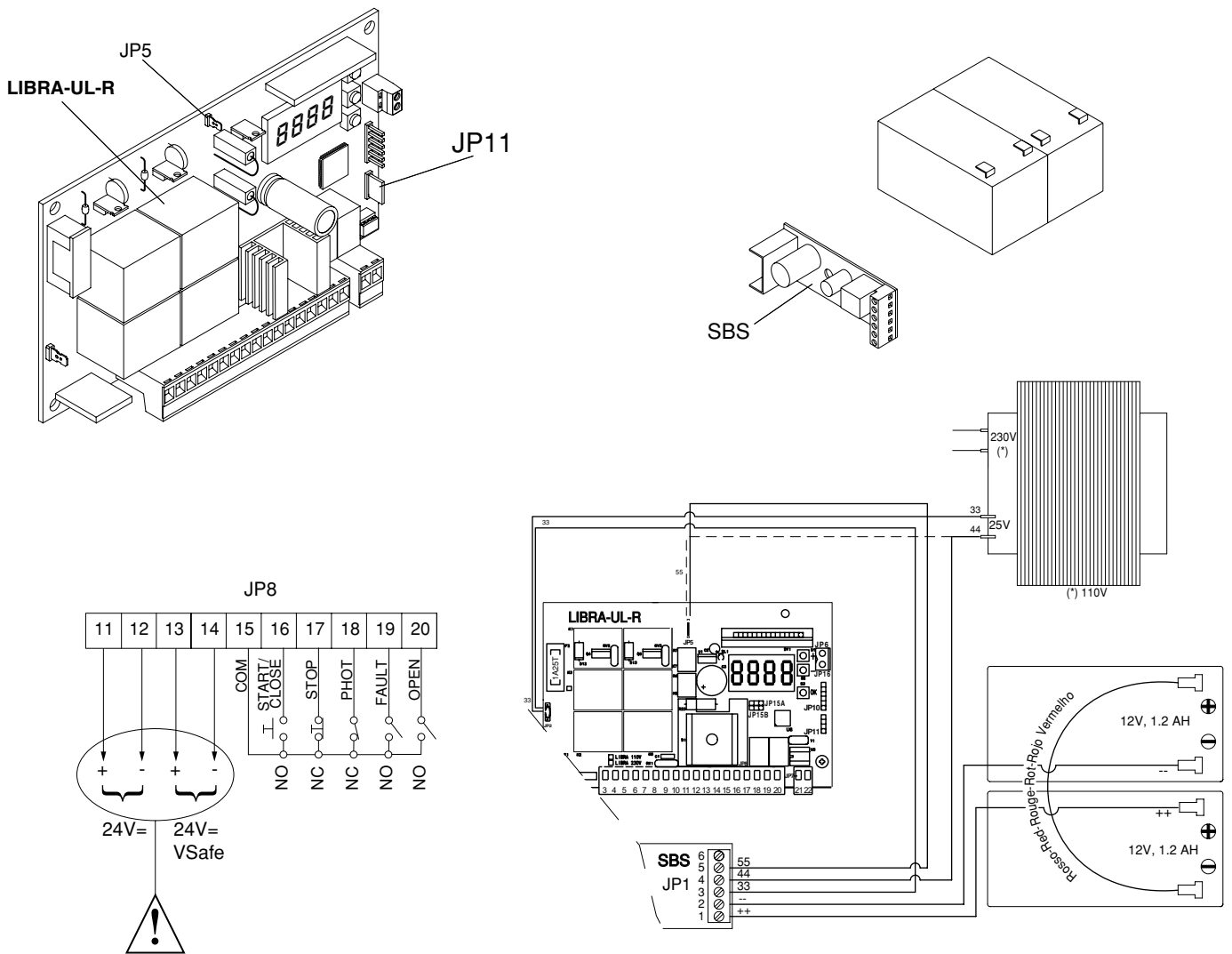

Fig. 6



Thank you for buying this product, our company is sure that you will be more than satisfied with the product's performance. The product is supplied with a "Warnings" leaflet and an "Instruction booklet". These should both be read carefully as they provide important information about safety, installation, operation and maintenance. This product complies with the recognised technical standards and safety regulations.

1) GENERAL OUTLINE

The **LIBRA-UL-R** control panel is supplied by the manufacturer with standard setting. Any alteration must be set by means of the incorporated display programmer or by means of UNIPRO. The Control unit completely supports the EELINK protocol.

Its main characteristics are:

- Control of two low-voltage motors up to 40W power
- Electronic torque setting with obstacle detection
- Limit-switch control inputs
- Separate inputs for safety devices
- Incorporated rolling-code radio receiver with transmitter cloning

2) SAFETY

If correctly installed and used, this automation device satisfies the required safety level standards. However, it is advisable to observe some practical rules in order to avoid accidental problems.

Before using the automation device, carefully read the operation instructions and keep them for future reference.

- Keep children, persons and things outside the automation working area, particularly during operation.
- Keep radio control or other control devices out of children's reach, in order to avoid any unintentional automation activation.
- Do not intentionally oppose the leaf movement.
- Do not attempt to open the gate by hand, if the actuator has not been released by means of the appropriate release knob.
- Do not modify the automation components.
- In case of malfunction, disconnect the power supply, activate the emergency release to gain access to the actuator and request the assistance of a qualified technician (installer).
- Before proceeding to any external cleaning operation, disconnect the mains powers supply and at least one of the battery pole, if fitted.
- Keep the photocell optical components and luminous signal indication devices clean. Check that the safety devices (photocells) are not obscured by branches or shrubs.
- For any direct assistance to the automation system, request the assistance of a qualified technician (installer).
- Have qualified personnel check the automation system once a year.
- **Entrance is reserved for vehicles, provide a separate entrance for pedestrians.**

3) FUNCTIONS

FOR THE INSTALLER: Fill in the table with the parameters set, in order to facilitate future modifications and maintenance operations.

The preset values are indicated between square brackets [].

PARAMETER MENU

Automatic Closing Time	[10s]	<input type="text"/>
Motor 1 torque	[50%]	<input type="text"/>
Motor 2 torque	[50%]	<input type="text"/>
Motor 1 slow-down torque	[45%]	<input type="text"/>
Motor 2 slow-down torque	[45%]	<input type="text"/>
Opening delay time	[1s]	<input type="text"/>
Closing delay time	[1s]	<input type="text"/>
Motor 1 Normal Speed Time	[15s]	<input type="text"/>
Motor 2 Normal Speed Time	[15s]	<input type="text"/>
Slow-down speed	[0]	<input type="text"/>
Zone	[0]	<input type="text"/>

LOGIC MENU

TCA (Automatic Closing Time)	[OFF]	<input type="text"/>
3 steps	[OFF]	<input type="text"/>
Impulse lock on opening	[OFF]	<input type="text"/>
Rapid closing	[OFF]	<input type="text"/>
Photocells on opening	[OFF]	<input type="text"/>
Photocell test	[OFF]	<input type="text"/>
No. motors in operation	[OFF]	<input type="text"/>
Lock hold	[OFF]	<input type="text"/>
Start / Close	[OFF]	<input type="text"/>
Fixed code	[OFF]	<input type="text"/>
Radio programming	[ON]	<input type="text"/>
Master	[OFF]	<input type="text"/>

4) SCRAPPING

Warning: This operation should only be carried out by qualified personnel. Materials must be disposed of in conformity with the current regulations. In case of scrapping, the automation devices do not entail any particular risks or danger. In case of materials to be recycled, these should be sorted out by type (electrical components, copper, aluminium, plastic etc.).

5) DISMANTLING

Warning: This operation should only be carried out by qualified personnel.

When the control unit is disassembled to be reassembled on another site, proceed as follows:

- Disconnect the power supply and the entire electrical installation.
- In the case where some of the components cannot be removed or are damaged, they must be replaced.

WARNINGS

Correct controller operation is only ensured when the data contained in the present manual are observed. The company is not to be held responsible for any damage resulting from failure to observe the installation standards and the instructions contained in the present manual.

The descriptions and illustrations contained in the present manual are not binding. The Company reserves the right to make any alterations deemed appropriate for the technical, manufacturing and commercial improvement of the product, while leaving the essential product features unchanged, at any time and without undertaking to update the present publication.

BFT S.P.A.

Via Lago di Vico 44
36015 Schio (VI) / *Italy*
Tel. 0039 445.696511 - Fax 0039 445.696522
www.bft.it - e-mail: sales@bft.it

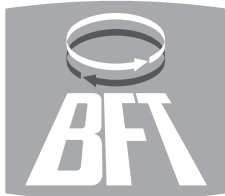
**BFT TORANTRIEBSSYSTEME GmbH**

Faber-Castell Str. 29
90522 Oberasbach / *Germany*
Tel. 0049 911 7660090 - Fax 0049 911 7660099
e-mail: service@bft-torantriebe.de

BFT AUTOMATION UK LTD

Unit 8E, Newby Road
Industrial Estate Hazel Grove
Stockport SK7 5DA / *England*
Tel. 0044 161 4560456 - Fax 0044 161 4569090
e-mail: info@bft.co.uk

AUTOMATISMES BFT FRANCE

13 Bdl. E. Michelet
69008 Lyon / *France*
Tel. 0033 4 78 76 09 88 - Fax 0033 4 78 76 92 23
e-mail: infofrance@bft.it

BFT BENELUX SA

Rue du commerce 12
1400 Nivelles / *Belgium*
Tel. 0032 67/ 55 02 00 - Fax 0032 67/ 55 02 01
mail: info@bftbenelux.be

BFT-ADRIA d.o.o.

Obrovac 39
51218 Dražice (RIJEKA) / *Croatia*
Tel. 00385 51 502 640 - Fax 00385 51 502 644
www.bft.hr - e-mail: info@bft.hr

BFT Polska Sp. z o.o.

ul. Szatwiowa 47
03-167 Warszawa / *Polska*
Tel. 0048 022 814 12 22 - Fax 0048 022 814 39 18
www.bft.com.pl - e-mail: biuro@bft.com.pl

BFT GROUP**ITALIBERICA DE AUTOMATISMOS S.L.**

España
www.bftautomatismos.com

P.I. Palau Nord, Sector F
C/Cami Can Basa nº 6-8
08400 GRANOLLERS *Barcelona*
Telf. +34 93 8614828 - Fax +34 93 8700394
e-mail: bftbcn@bftautomatismos.com

P.I. Comendador,
C/ informàtica, Nave 22
19200 AZUQUECA DE HENARES *Guadalajara*
Telf. +34 949 26 32 00 - Fax. +34 949 26 24 51
e-mail: bft@bftautomatismos.com