

FlexPak® 3000
Field Current Regulator Kit
Installation Instructions

M/N 911FK0041, 911FK0101, and 911FK0151

Instruction Manual D2-3336-1

RELIANCE
ELECTRIC 

The information in the user's manual is subject to change without notice.

Read this manual in its entirety before installing and powering the drive. Observe all **DANGER**, **WARNING**, and **CAUTION** advisories; these advisories point out potentially hazardous procedures and conditions. All three types of advisories are enclosed in a box to call attention to them.

- A **DANGER** alerts a person that severe bodily injury or loss of life could occur if procedures are not followed.
- A **WARNING** alerts a person to potential bodily injury if procedures are not followed.
- A **CAUTION** alerts a person that if procedures are not followed, damage to, or destruction of equipment could result.

DANGER

ONLY QUALIFIED ELECTRICAL PERSONNEL FAMILIAR WITH THE CONSTRUCTION AND OPERATION OF THIS EQUIPMENT AND THE HAZARDS INVOLVED SHOULD INSTALL, ADJUST, OPERATE AND/OR SERVICE THIS EQUIPMENT. READ AND UNDERSTAND THIS MANUAL IN ITS ENTIRETY BEFORE PROCEEDING. FAILURE TO OBSERVE THIS PRECAUTION COULD RESULT IN SEVERE BODILY INJURY OR LOSS OF LIFE.

CAUTION: The user is responsible for conforming with all applicable local, national, and international codes. Failure to observe this precaution could result in damage to, or destruction of, the equipment.

FlexPak 3000® and Reliance® are registered trademarks of Reliance Electric Company or its subsidiaries.

Table of Contents

1.0	Introduction	1-1
1.1	Related Publications	1-3
1.2	Getting Assistance from Reliance Electric	1-3
2.0	Installing the Field Current Regulator Kit on 1.5 - 30 HP @ 230 VAC and 3 - 60 HP @ 460 VAC Drives	2-1
2.1	Opening the Drive Cover and Carrier	2-1
2.2	Removing the Standard or Enhanced Field Supply Board	2-2
2.3	Installing the Field Current Regulator Board	2-2
2.4	Wiring the Field Current Regulator Board	2-2
2.5	Replacing the Drive Fuses	2-2
2.6	Replacing the Carrier and Drive Cover	2-3
2.7	Modifying the Drive Configuration	2-3
3.0	Installing the Field Current Regulator Kit on 40 - 75 HP @ 230 VAC and 75 - 150 HP @ 460 VAC Drives	3-1
3.1	Opening the Drive Cover and Carrier, and Removing the AC Disconnect	3-1
3.2	Removing the Standard or Enhanced Field Supply Board	3-2
3.3	Installing the Field Current Regulator Board	3-2
3.4	Wiring the Field Current Regulator Board	3-2
3.5	Replacing the Drive Fuses	3-3
3.6	Reinstalling the Auxiliary Chassis Cover, Carrier and Drive Cover	3-3
3.7	Modifying the Drive Configuration	3-3
4.0	Installing the Field Current Regulator Kit on 100 - 150 HP @ 230 VAC and 200 - 300 HP @ 460 VAC Drives	4-1
4.1	Opening the Cover and Carrier	4-1
4.2	Removing the Enhanced Field Supply Board	4-2
4.3	Installing the Field Current Regulator Board	4-2
4.4	Wiring the Field Current Regulator Board	4-2
4.5	Reinstalling the OIM Carrier and Cover	4-3
4.6	Replacing the Drive Fuses	4-3
4.7	Reinstalling the Drive Cover	4-3
4.8	Modifying the Drive Configuration	4-3
5.0	Modifying the Drive Configuration	5-1
5.1	Setting Parameter 510 (MOTOR HOT FLD AMPS)	5-1
5.2	Setting Parameter 511 (FIELD ECONOMY REF)	5-3

Appendices

Appendix A

Field Current Regulator Description	A-1
---	-----

List of Figures

Figure 1.1 - Field Current Regulator Board	1-2
Figure 1.2 - Cable Assemblies	1-3
Figure 2.1 - Removing the Standard/Enhanced Field Supply (3-60 HP Drives)	2-3
Figure 2.2 - Cable Routing (3 - 60 HP Drives)	2-4
Figure 2.3 - Regulator Board Cable Connectors	2-4
Figure 3.1 - Removing the Standard/Enhanced Field Supply (75 - 150 HP Drives)	3-4
Figure 3.2 - Cable Routing (75 - 150 HP Drives)	3-4
Figure 4.1 - Removing the Standard/Enhanced Field Supply (200 - 300 HP Drives)	4-4
Figure 4.2 - Cable Routing (200 - 300 HP Drives)	4-4
Figure A.1 - Field Control Loop	A-2
Figure A.2 - Drive Operation Over the Constant Torque and Constant Power Range	A-3

List of Tables

Table 1.1 - Verifying the Field Current Regulator Kit Matches the Drive	1-1
Table 1.2 - Field Current Regulator Kit Contents	1-1
Table A.1 - Field Current Feedback Scaling	A-3

1.0 INTRODUCTION

The products described in this instruction manual are manufactured or distributed by Reliance® Electric Industrial Company.

This instruction manual describes how to install and configure the optional Field Current Regulator kits used by FlexPak® 3000 drives. The Field Current Regulator, which includes a field regulator and a field supply, can be used only in drives that have software version 3.00 (REGULATOR SW VERSION parameter = 3.00) or later. When the kit is installed, a field control loop is enabled, allowing the user to adjust field control functions. The field control loop operates in both the constant torque (armature control) range and the constant power (field control) range. See Appendix A for a description of the field control loop.

There are three Field Current Regulator kits available for use in FlexPak 3000 drives. They differ according to the maximum motor field current they support. Use the kit that provides the maximum motor field current (including that necessary for field forcing) required for your application. Note that using a Field Current Regulator with a higher amperage rating than is needed will decrease control resolution. Refer to table 1.1 to ensure you have the correct kit for your application and to table 1.2 for a list of the kit contents. See figures 1.1 and 1.2 for illustrations of the Field Current Regulator board and cable assemblies.

Table 1.1 - Verifying the Field Current Regulator Kit Matches the Drive

Field Current Regulator Model Number	Maximum Motor Field Current
911FK0041	4 A
911FK0101	10 A
911FK0151	15 A

Table 1.2 - Field Current Regulator Kit Contents

Kit Model Number	Part Number	Description	Quantity
911FK0041	707973-10R	Printed Circuit Board Assembly	1
	64676-30M	25 A Fuse, UL Class CC, 600 V	3
	707973-12R	Cable Assembly	1
	707973-12S	Cable Assembly	1
	69306-3D	Cable Tie Wrap	8
	69752-146D	Plug Cap	1
	D2-3336	Instruction Manual	1
911FK0101	707973-10S	Printed Circuit Board Assembly	1
	64676-30M	25 A Fuse, UL Class CC, 600 V	3
	707973-12R	Cable Assembly	1
	707973-12S	Cable Assembly	1
	69306-3D	Cable Tie Wrap	8
	69752-146D	Plug Cap	1
	D2-3336	Instruction Manual	1
911FK0151	707973-10T	Printed Circuit Board Assembly	1
	64676-30M	25 A Fuse, UL Class CC, 600 V	3
	707973-12R	Cable Assembly	1
	707973-12S	Cable Assembly	1
	69306-3D	Cable Tie Wrap	8
	69752-146D	Plug Cap	1
	D2-3336	Instruction Manual	1

Top View

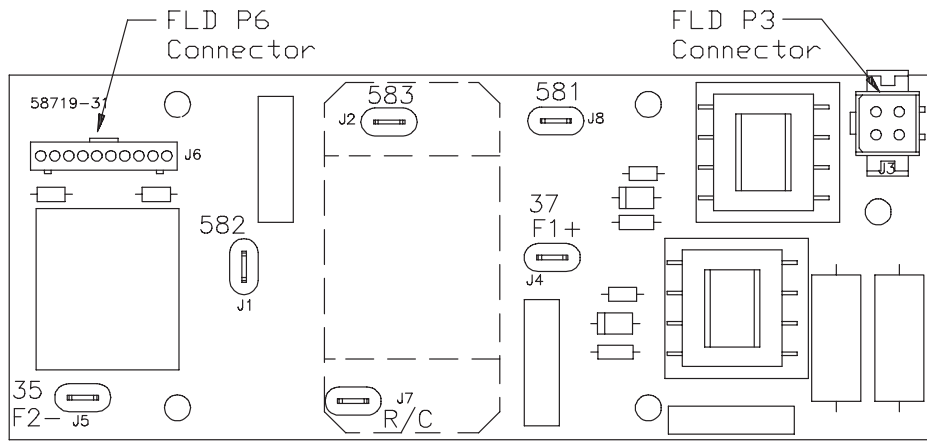

Side View

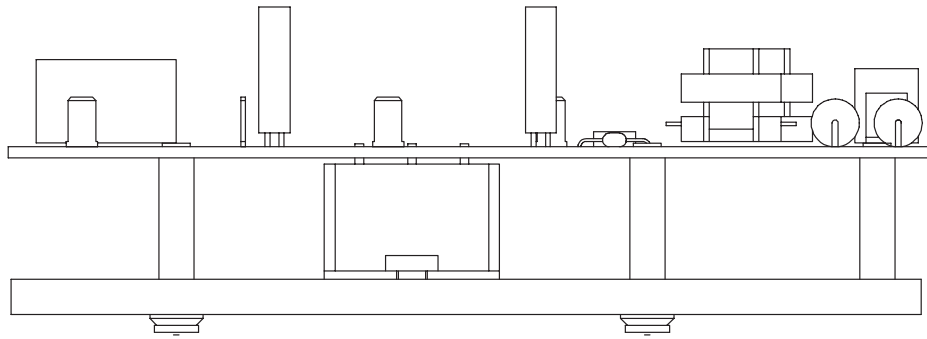

Figure 1.1 - Field Current Regulator Board

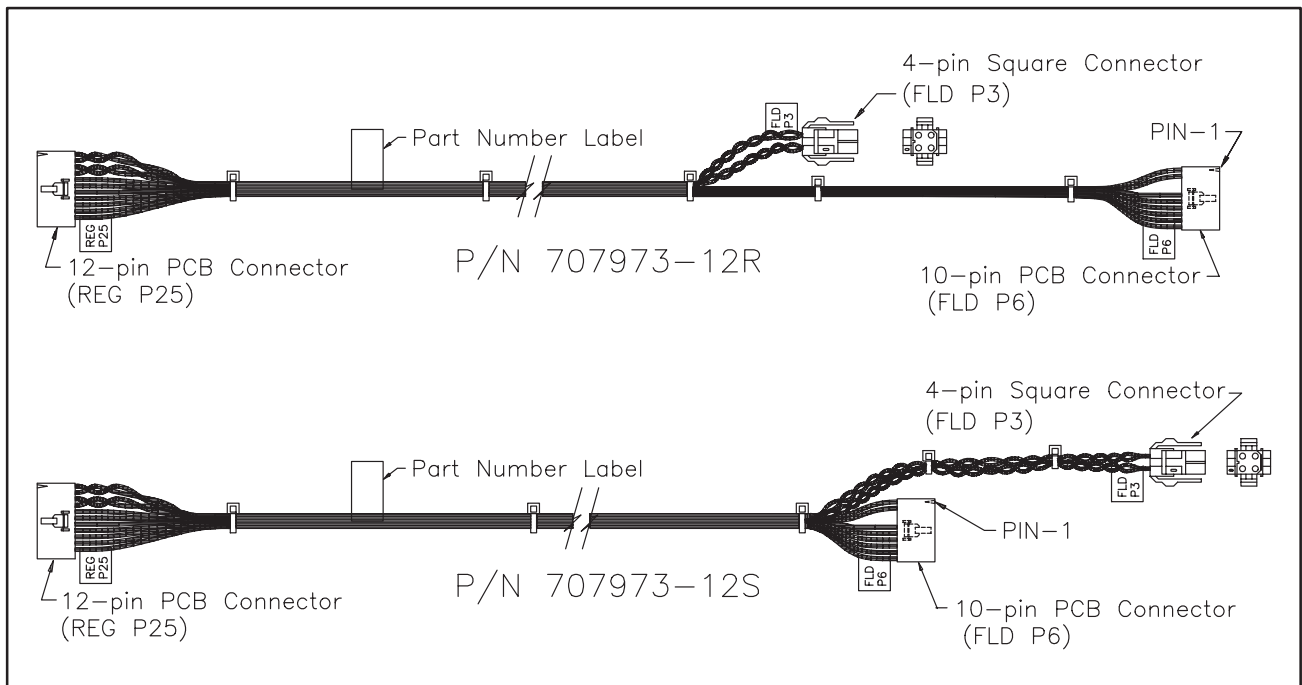

Figure 1.2 - Cable Assemblies

1.1 Related Publications

This manual describes the Field Current Regulator kit and its associated FlexPak 3000 software parameters. You will also need the FlexPak 3000 DC Drive instruction manual, which describes the drive hardware and software.

1.2 Getting Assistance from Reliance Electric

If you have any questions or problems with the products described in this instruction manual, contact your local Reliance Electric sales office. For technical assistance, call 1-800-RELIANCE.

2.0 INSTALLING THE FIELD CURRENT REGULATOR KIT ON 1.5 - 30 HP @ 230 VAC AND 3 - 60 HP @ 460 VAC DRIVES

DANGER

ONLY QUALIFIED ELECTRICAL PERSONNEL FAMILIAR WITH THE CONSTRUCTION AND OPERATION OF THIS EQUIPMENT AND THE HAZARDS INVOLVED SHOULD INSTALL, ADJUST, OPERATE AND/OR SERVICE THIS EQUIPMENT. READ AND UNDERSTAND THIS MANUAL IN ITS ENTIRETY BEFORE PROCEEDING. FAILURE TO OBSERVE THIS PRECAUTION COULD RESULT IN SEVERE BODILY INJURY OR LOSS OF LIFE.

DANGER

THE DRIVE IS AT LINE VOLTAGE WHEN CONNECTED TO INCOMING AC POWER. DISCONNECT, TAG, AND LOCKOUT ALL INCOMING POWER TO THE DRIVE BEFORE PERFORMING THE FOLLOWING PROCEDURE. FAILURE TO OBSERVE THIS PRECAUTION COULD RESULT IN SEVERE BODILY INJURY OR LOSS OF LIFE.

Installing the Field Current Regulator kit on 3 - 60 HP drives requires completing the following steps. When you have finished installing the kit, adjust the required drive parameters as described in chapter 5 before using the drive.

- Opening the cover and carrier
- Removing the Standard or Enhanced Field Supply board
- Installing the Field Current Regulator board
- Wiring the Field Current Regulator board
- Replacing the drive fuses
- Reinstalling the drive carrier and cover
- Modifying the drive configuration

These steps are described in detail below.

2.1 Opening the Drive Cover and Carrier

WARNING

THE DRIVE CONTAINS PRINTED CIRCUIT BOARDS THAT ARE STATIC-SENSITIVE. AN ANTI-STATIC WRIST BAND SHOULD BE WORN BY ANY PERSON WHO TOUCHES THE DRIVE'S COMPONENTS, CONNECTORS, OR LEADS. ERRATIC MACHINE OPERATION AND DAMAGE TO, OR DESTRUCTION OF, EQUIPMENT MAY RESULT IF THIS PROCEDURE IS NOT FOLLOWED. FAILURE TO OBSERVE THIS PRECAUTION MAY RESULT IN BODILY INJURY.

- Step 1. Turn off, lockout, and tag power to the drive.
- Step 2. Loosen the cover retaining screws and remove the cover.
- Step 3. Loosen the captive screw at the upper right corner of the drive's Operator Interface Module (OIM) carrier and swing open the carrier.

2.2 Removing the Standard or Enhanced Field Supply Board

- Step 1. Locate the Standard or Enhanced Field Supply board in the drive. See figure 2.1.
- Step 2. Disconnect the drive's wire harness connections from the existing field supply board's 581, 582, 583, F2/35 and F1/37 spade connectors.
- Step 3. Follow the field supply board's wire harness to the P4 connector on the Power Interface board. Unplug the harness from the P4 connector.
- Step 4. Install the plug cap (P/N 69752-146D) on the Power Interface board's P4 connector. See figure 2.1.
- Step 5. Locate the field supply's four mounting screws on the outside of the drive's right side panel.
- Step 6. Remove the four mounting screws from the outside of the drive and remove the field supply board.

2.3 Installing the Field Current Regulator Board

- Step 1. Remove the four mounting screws from the back of the Field Current Regulator board.
- Step 2. Connect the wire harness connectors labeled 581, 582, 583, F2/35 and F1/37 to the corresponding terminals on the Field Current Regulator board. See figure 1.1.
- Step 3. Attach the Field Current Regulator cable assembly's (P/N 707973-12R) FLD P6 and FLD P3 connectors to the corresponding terminals on the Field Current Regulator board. See figure 1.1.
- Step 4. Working from the inside of the drive, align the Field Current Regulator board's mounting holes with the mounting holes on the drive's right side panel. See figure 2.2.
- Step 5. Working from the outside of the drive, insert one of the mounting screws (removed in step 10) through one of the mounting holes on the drive's right side panel and into the corresponding mounting hole on the Field Current Regulator board.
- Step 6. Repeat step 5 for the remaining three mounting holes.

2.4 Wiring the Field Current Regulator Board

- Step 1. The Operator Interface Module (OIM) or Drive Configuration Module (DCM) must be removed to provide access to the Regulator board. Remove the screws that hold the OIM or DCM to the carrier, and remove the OIM/DCM.
- Step 2. Remove the three screws that hold the Regulator board in place, and slide the Regulator board slightly to the right.
- Step 3. From the back of the carrier, push the end of the Field Current Regulator cable assembly with the REG P25 connector through the opening in the carrier (above the ribbon cable). See figure 2.2.
- Step 4. Connect the REG P25 connector to the J25 terminal on the Regulator board. See figure 2.3.
- Step 5. Slide the Regulator board back into place and secure it with its mounting screws.
- Step 6. Reinstall the OIM/DCM.
- Step 7. Use the supplied cable ties to fasten the Field Current Regulator cable assembly to the drive's fan or support bar.

2.5 Replacing the Drive Fuses

- Step 1. Remove the three fuses labeled 6FU, 7FU, and 8FU from the drive's fuse block.
- Step 2. Install the three provided 25 A, 600 V fuses (P/N 64676-30M) in the fuse block in positions 6FU, 7FU, and 8FU.

2.6 Replacing the Carrier and Drive Cover

- Step 1. Close the carrier and secure it in place with its captive screw.
- Step 2. Reinstall the drive cover and secure it in place with its screws
- Step 3. Reconnect power to the drive. Hardware installation is complete.
- Step 4. Remove the lockout and tag
- Step 5. Turn on power to the drive.

2.7 Modifying the Drive Configuration

Go to chapter 5 for information on setting parameters for the Field Current Regulator kit.

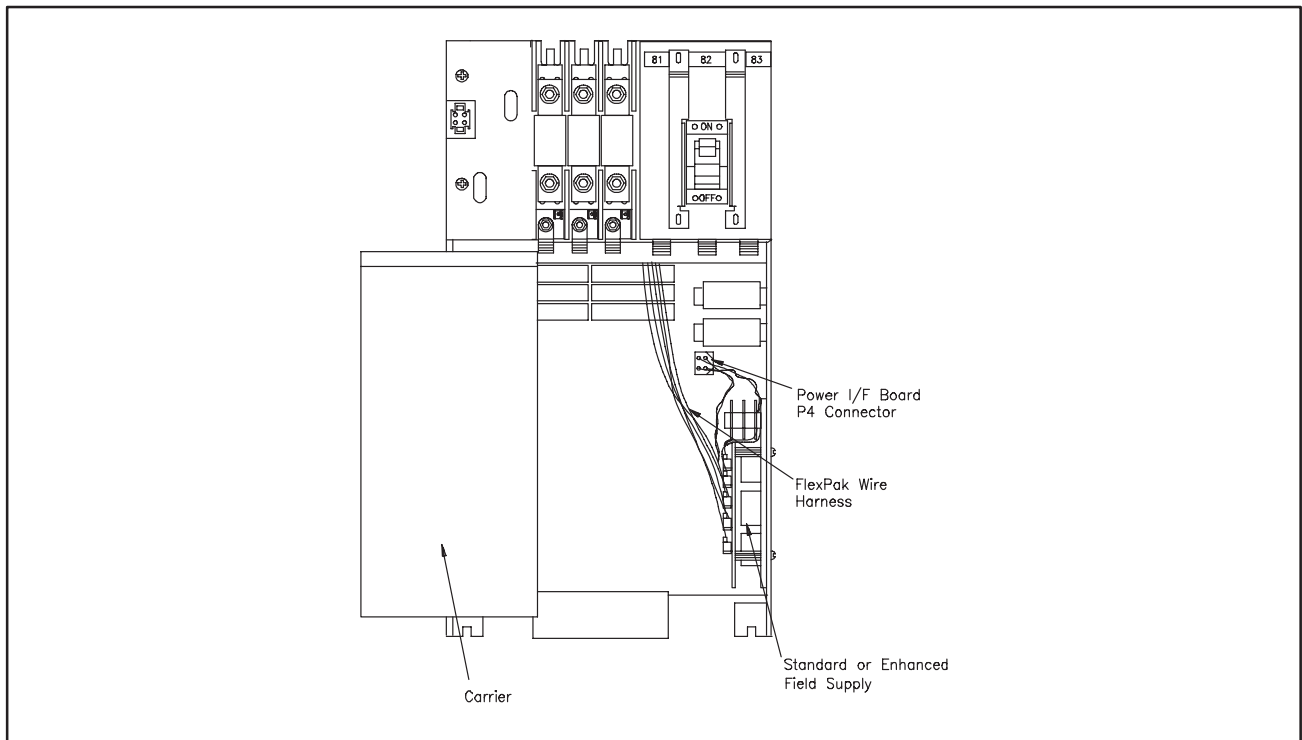

Figure 2.1 - Removing the Standard/Enhanced Field Supply (3-60 HP Drives)

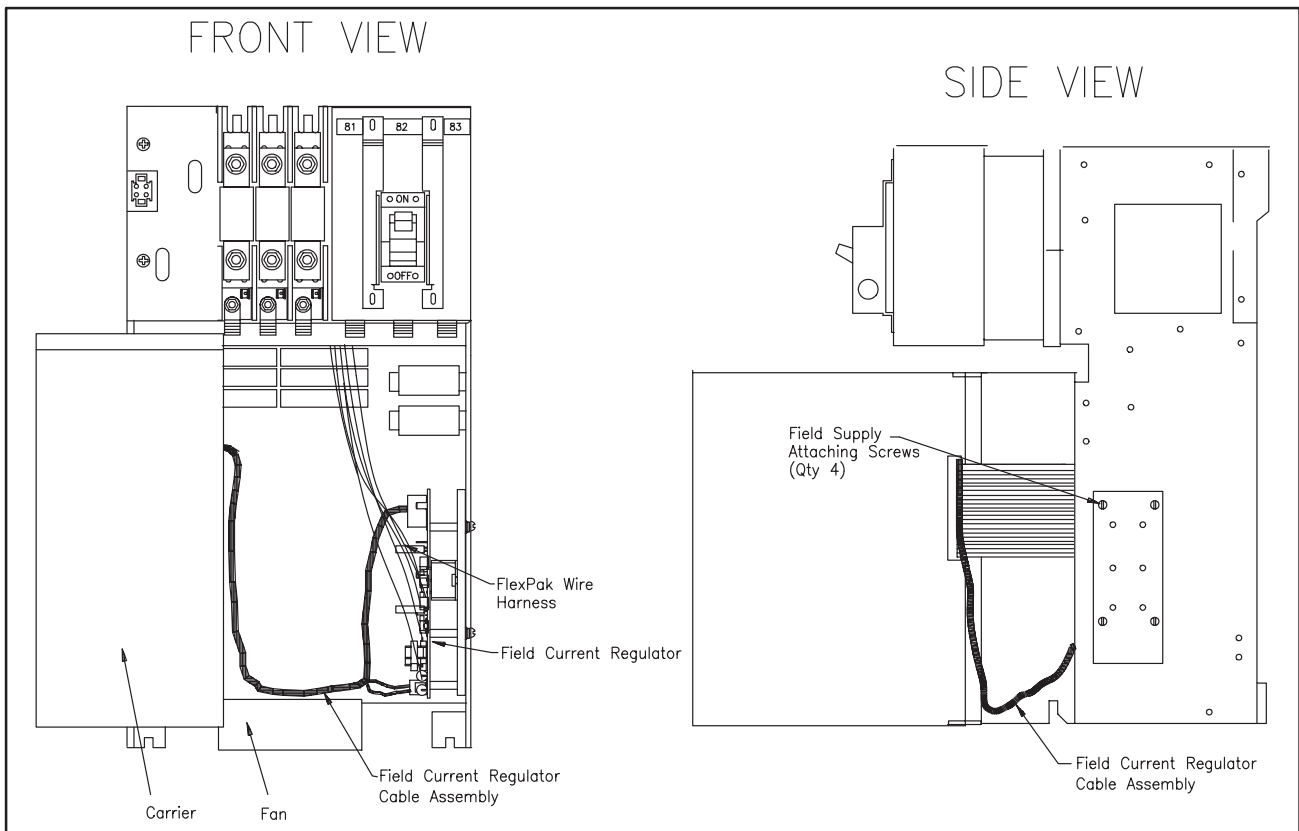

Figure 2.2 - Cable Routing (3 - 60 HP Drives)

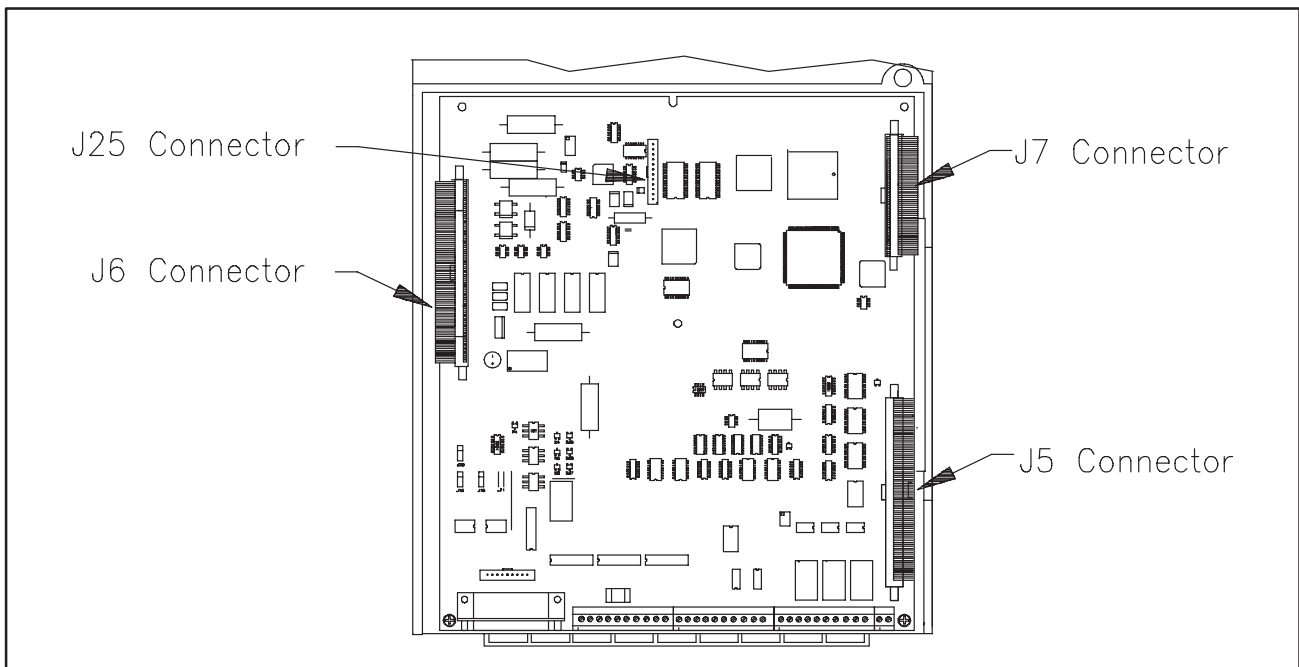

Figure 2.3 - Regulator Board Cable Connectors

3.0 INSTALLING THE FIELD CURRENT REGULATOR KIT ON 40 - 75 HP @ 230 VAC AND 75 - 150 HP @ 460 VAC DRIVES

DANGER

ONLY QUALIFIED ELECTRICAL PERSONNEL FAMILIAR WITH THE CONSTRUCTION AND OPERATION OF THIS EQUIPMENT AND THE HAZARDS INVOLVED SHOULD INSTALL, ADJUST, OPERATE AND/OR SERVICE THIS EQUIPMENT. READ AND UNDERSTAND THIS MANUAL IN ITS ENTIRETY BEFORE PROCEEDING. FAILURE TO OBSERVE THIS PRECAUTION COULD RESULT IN SEVERE BODILY INJURY OR LOSS OF LIFE.

DANGER

THE DRIVE IS AT LINE VOLTAGE WHEN CONNECTED TO INCOMING AC POWER. DISCONNECT, TAG, AND LOCKOUT ALL INCOMING POWER TO THE DRIVE BEFORE PERFORMING THE FOLLOWING PROCEDURE. FAILURE TO OBSERVE THIS PRECAUTION COULD RESULT IN SEVERE BODILY INJURY OR LOSS OF LIFE.

Installing the Field Current Regulator kit on 75-150 HP drives requires completing the following steps. When you have finished installing the kit, adjust the required drive parameters as described in chapter 5 before using the drive.

- Opening the cover and carrier
- Removing the Standard or Enhanced Field Supply board
- Installing the Field Current Regulator board
- Wiring the Field Current Regulator board
- Replacing the drive fuses
- Reinstalling the drive carrier and cover
- Modifying the drive configuration

These steps are described in detail below.

3.1 Opening the Drive Cover and Carrier, and Removing the AC Disconnect

WARNING

THE DRIVE CONTAINS PRINTED CIRCUIT BOARDS THAT ARE STATIC-SENSITIVE. AN ANTI-STATIC WRIST BAND SHOULD BE WORN BY ANY PERSON WHO TOUCHES THE DRIVE'S COMPONENTS, CONNECTORS, OR LEADS. ERRATIC MACHINE OPERATION AND DAMAGE TO, OR DESTRUCTION OF, EQUIPMENT MAY RESULT IF THIS PROCEDURE IS NOT FOLLOWED. FAILURE TO OBSERVE THIS PRECAUTION MAY RESULT IN BODILY INJURY.

- Step 1. Turn off, lockout, and tag power to the drive.
- Step 2. Loosen the drive cover retaining screws and remove the cover..
- Step 3. Loosen the captive screw at the upper right corner of the drive's Operator Interface Module (OIM) carrier and swing open the carrier. If the drive is equipped with an AC line disconnect, go to step 4. Otherwise, go to step 5.

- Step 4. **Drives with an AC line disconnect only:** Remove the four screws that fasten the AC line disconnect to the auxiliary chassis cover. Then, lift and remove the AC line disconnect from the auxiliary chassis cover. See figure 3.1.
- Step 5. Loosen the two screws at the right side of the motor terminal panel to free the tabs on the auxiliary chassis cover. Do not to remove the screws completely. See figure 3.1.
- Step 6. Remove the top and bottom screws fastening the auxiliary chassis cover to the drive's right side panel.
- Step 7. Loosen the middle screw that fastens the auxiliary chassis cover/circuit breaker panel to the drive's right side panel. Slightly swing out the auxiliary chassis cover and remove it.

3.2 Removing the Standard or Enhanced Field Supply Board

- Step 1. Locate the Standard or Enhanced Field Supply board in the drive. See figure 3.1.
- Step 2. Disconnect the drive's wire harness connections from the existing field supply board's 581, 582, 583, F2/35 and F1/37 spade connectors.
- Step 3. Follow the field supply board's wire harness to the P4 connector on the Power Interface board. Unplug the harness from the P4 connector.
- Step 4. Install the plug cap (P/N 69752-146D) on the Power Interface board's P4 connector. See figure 2.1.
- Step 5. Remove the four (4) mounting screws from the outside of the drive's right side panel and remove the field supply board.

3.3 Installing the Field Current Regulator Board

- Step 1. Remove the four (4) mounting screws from the back of the Field Current Regulator board.
- Step 2. Connect the drive's wire harness connectors labeled 581, 582, 583, F2/35 and F1/37 to the corresponding terminals on the Field Current Regulator board. See figure 1.1 for the location of the terminals.
- Step 3. Attach the Field Current Regulator cable assembly (P/N 707973-12S) FLD P6 and FLD P3 connectors to the corresponding terminals on the Field Current Regulator. See figure 1.1.
- Step 4. Route the free end of the Field Current Regulator cable assembly under the fuse block, through the grommet, and across the heat sink, to the left side of the drive following the same path as the red and blue control wiring harness. Then run the cable assembly inside the front of the drive to the OIM carrier. See figure 3.2.
- Step 5. Working from the inside of the drive, align the Field Current Regulator board's mounting holes with the mounting holes on the drive's right side panel.
- Step 6. Working from the outside of the drive, insert one of the mounting screws (removed in step 13) through one of the mounting holes on the drive's right side panel and into the corresponding mounting hole on the Field Current Regulator board. Tighten the screw to hold the board in place.
- Step 7. Repeat step 6 for the remaining three mounting screws.

3.4 Wiring the Field Current Regulator Board

- Step 1. The Operator Interface Module (OIM) or Drive Configuration Module (DCM) must be removed to provide access to the Regulator board. Remove the screws that hold the OIM (or DCM) to the carrier, and remove the OIM/DCM.
- Step 2. Remove the three screws that hold the Regulator board in place, and slide the Regulator board slightly to the right.

- Step 3. From the back of the carrier, push the end of the Field Current Regulator cable assembly with the REG P25 connector through the opening in the carrier (above the ribbon cable). See figure 3.2.
- Step 4. Connect the REG P25 connector to the J25 terminal on the Regulator board. See figure 2.3.
- Step 5. Slide the Regulator board back into place and secure it with its mounting screws..
- Step 6. Reinstall the OIM/DCM.
- Step 7. Use the supplied cable ties to fasten the Field Current Regulator cable assembly to the drive's fan or support bar.

3.5 Replacing the Drive Fuses

- Step 1. Remove the three fuses labeled 6FU, 7FU, and 8FU from the drive's fuse block.
- Step 2. Install the three provided 25 A, 600 V fuses (P/N 64676-30M) in the fuse block in positions 6FU, 7FU, and 8FU.

3.6 Reinstalling the Auxiliary Chassis Cover, Carrier and Drive Cover

- Step 1. Insert the tabs on the left side of the auxiliary chassis cover into the slots on the right side of the drive's motor terminal panel.
- Step 2. Align the auxiliary chassis cover over the middle screw on the drive's right side panel and over the top and bottom mounting holes.
- Step 3. Insert the top and bottom screws into the mounting screw holes and then tighten all three mounting screws (top, bottom, and middle).
- Step 4. Tighten the two screws on the right side of the motor terminal panel to secure the auxiliary chassis cover's tabs in place.
- Step 5. Drives with an AC line disconnect only: Align the AC line disconnect over the mounting holes on the auxiliary chassis cover, then secure it in place with the four screws removed earlier.
- Step 6. Close the OIM carrier and secure it in place with its captive screw.
- Step 7. Reinstall the drive cover and secure it in place with its screws. Hardware installation is complete.
- Step 8. Reconnect power to the drive.
- Step 9. Remove the lockout and tag.
- Step 10. Turn on power to the drive.

3.7 Modifying the Drive Configuration

Go to chapter 5 for information on setting parameters for the Field Current Regulator kit.

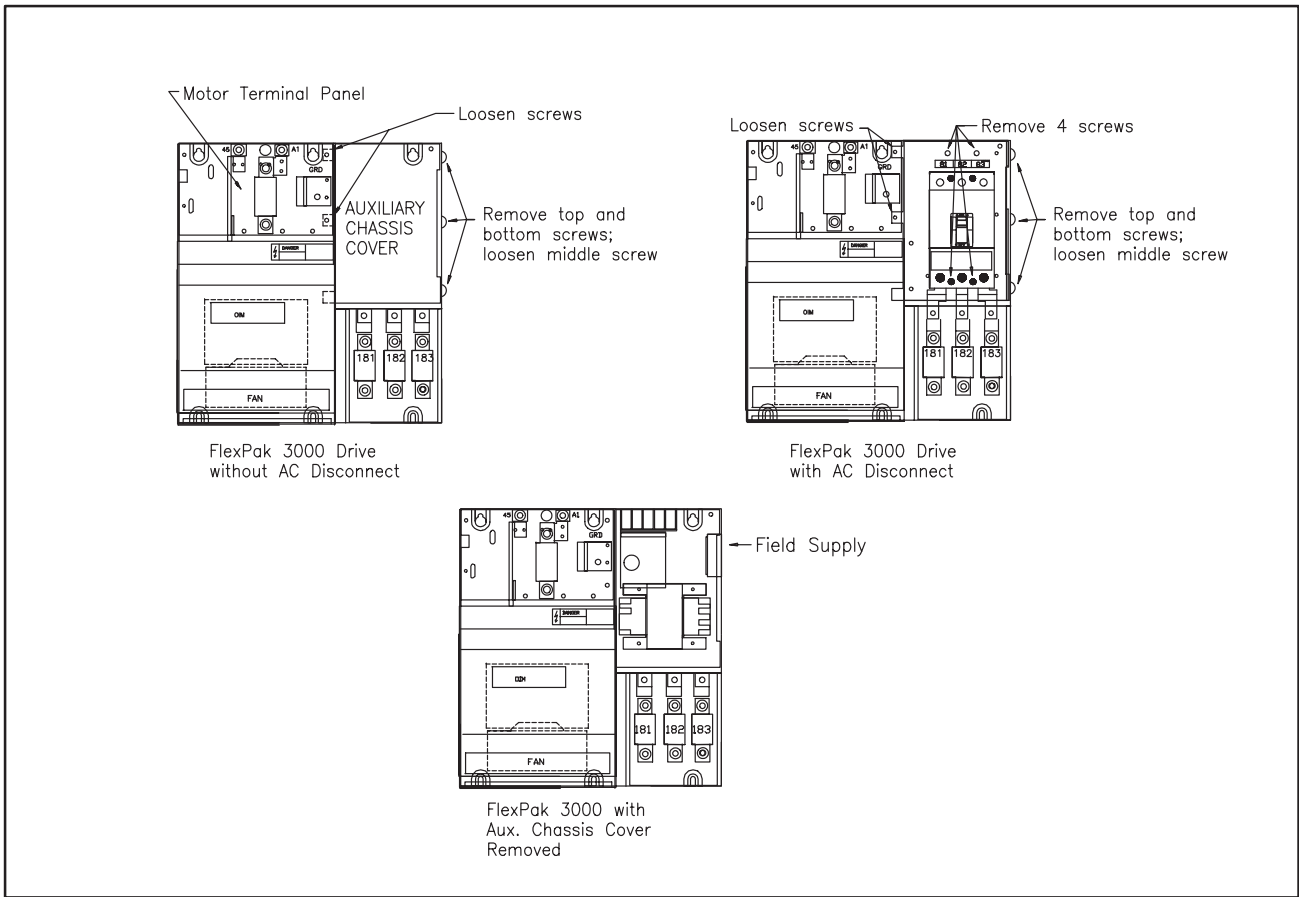

Figure 3.1 - Removing the Standard/Enhanced Field Supply (75 - 150 HP Drives)

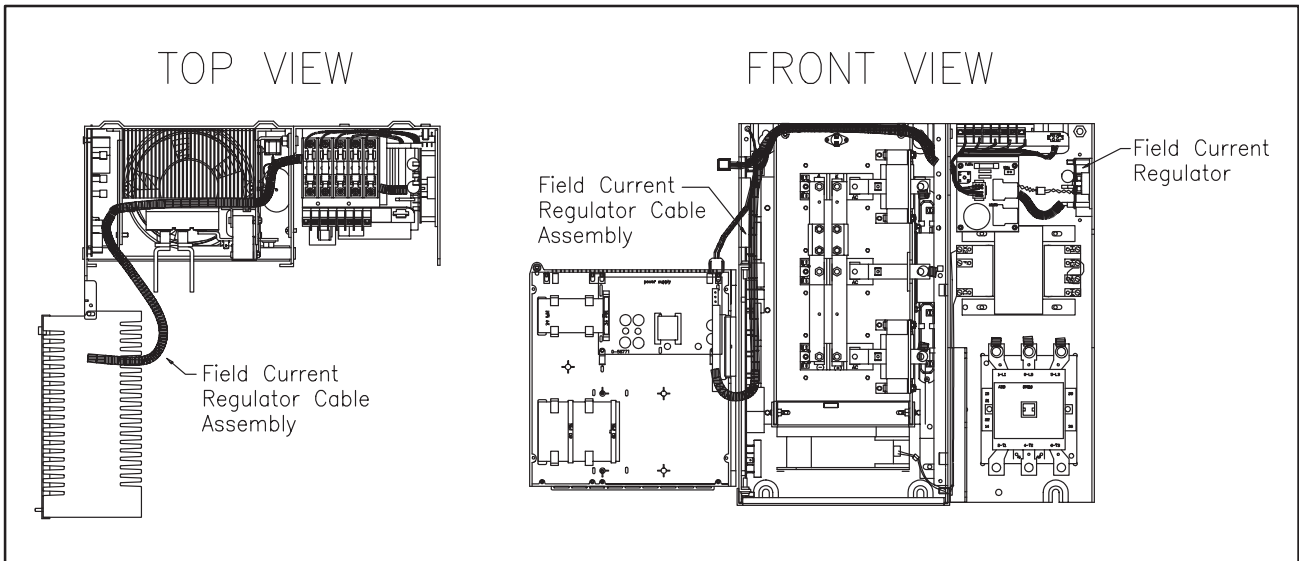

Figure 3.2 - Cable Routing (75 - 150 HP Drives)

4.0 INSTALLING THE FIELD CURRENT REGULATOR KIT ON 100 - 150 HP @ 230 VAC AND 200 - 300 HP @ 460 VAC DRIVES

DANGER

ONLY QUALIFIED PERSONNEL FAMILIAR WITH THE CONSTRUCTION AND OPERATION OF THIS EQUIPMENT AND THE HAZARDS INVOLVED SHOULD INSTALL, ADJUST, OPERATE, AND/OR SERVICE THIS EQUIPMENT. READ AND UNDERSTAND THIS INSTRUCTION MANUAL IN ITS ENTIRETY BEFORE PROCEEDING. FAILURE TO OBSERVE THIS PRECAUTION COULD RESULT IN SEVERE BODILY INJURY OR LOSS OF LIFE.

DANGER

THE DRIVE IS AT LINE VOLTAGE WHEN CONNECTED TO INCOMING AC POWER. DISCONNECT, TAG, AND LOCKOUT ALL INCOMING POWER TO THE DRIVE BEFORE PERFORMING THE FOLLOWING PROCEDURE. FAILURE TO OBSERVE THIS PRECAUTION COULD RESULT IN SEVERE BODILY INJURY OR LOSS OF LIFE.

Installing the Field Current Regulator kit on 200-300 HP drives requires completing the following steps. When you have finished installing the kit, adjust the required drive parameters as described in chapter 5 before using the drive.

- Opening the cover and carrier
- Removing the Enhanced Field Supply board
- Installing the Field Current Regulator board
- Wiring the Field Current Regulator board
- Replacing the drive fuses
- Reinstalling the drive carrier and cover
- Modifying the drive configuration

These steps are described in detail below.

4.1 Opening the Cover and Carrier

WARNING

THE DRIVE CONTAINS PRINTED CIRCUIT BOARDS THAT ARE STATIC-SENSITIVE. AN ANTI-STATIC WRIST BAND SHOULD BE WORN BY ANY PERSON WHO TOUCHES THE DRIVE'S COMPONENTS, CONNECTORS, OR LEADS. ERRATIC MACHINE OPERATION AND DAMAGE TO, OR DESTRUCTION OF, EQUIPMENT MAY RESULT IF THIS PROCEDURE IS NOT FOLLOWED. FAILURE TO OBSERVE THIS PRECAUTION MAY RESULT IN BODILY INJURY.

- Step 1. Turn off, lockout, and tag power to the drive.
- Step 2. Remove the plastic cover from the right side of the drive.
- Step 3. Loosen the two screws holding the OIM cover in place and remove the OIM cover.
- Step 4. Loosen the captive screw at the upper right corner of the OIM carrier and then swing the carrier open. Note that the screw is designed to stay attached to the carrier when it is loosened; do not attempt to remove it.

- Step 5. Locate the two plastic anchors holding the hinged mounting panel in place. Release the anchors by inserting the tip of a flat-bladed screwdriver into the notch on the anchors and twist so the notch is vertical. Then swing the panel open.

4.2 Removing the Enhanced Field Supply Board

- Step 1. Locate the Enhanced Field Supply board. It is attached to the right side of the drive, behind the line fuse panel, and can be accessed through the bottom of the drive. See figure 4.1.
- Step 2. Remove the four field supply mounting screws from the outside of the drive's right side panel and remove the field supply.
- Step 3. Disconnect the drive's wire harness from the field supply board's 581, 582, 583, F2/35, and F1/37 connectors.
- Step 4. Follow the field supply board's wire harness to the P4 connector on the Power Interface board. Unplug the harness from the P4 connector.
- Step 5. Install the plug cap (P/N 69752-146D) on the Power Interface board's P4 connector.

4.3 Installing the Field Current Regulator Board

- Step 1. Remove the four (4) mounting screws from the back of the Field Current Regulator board.
- Step 2. Connect the drive's wire harness connectors labeled 582, 582, 583, F2/35, and F1/37 to the corresponding terminals on the Field Current Regulator board. See figure 1.1 for the location of the terminals.
- Step 3. Attach the Field Current Regulator cable assembly (P/N 707973-12S) connectors FLD P6 and FLD P3 to the corresponding terminals on the Field Current Regulator.
- Step 4. Route the free end of the Field Current Regulator cable assembly to the left side of the drive and into the OIM carrier. Follow the path illustrated in figure 4.2. This is the same path used by the control wiring harness.
- Step 5. Working from the inside of the bottom of the drive, align the Field Current Regulator board's mounting holes with the mounting holes on the drive's right side panel. See figure 4.2.
- Step 6. Working from the outside of the drive, insert one of the mounting screws (removed in step 11) through one of the mounting holes on the drive's right side panel and into the corresponding mounting hole on the Field Current Regulator board. Tighten the screw to hold the board in place.
- Step 7. Repeat step 6 for the remaining three mounting screws.

4.4 Wiring the Field Current Regulator Board

- Step 1. The Operator Interface Module (OIM) or Drive Configuration Module (DCM) must be removed to provide access to the Regulator board. Remove the screws that hold the OIM (or DCM) to the carrier, and remove the OIM/DCM.
- Step 2. Remove the three screws that hold the Regulator board in place, then slide the Regulator board slightly to the right.
- Step 3. From the back of the OIM carrier, push the end of the Field Current Regulator cable assembly with the REG P25 connector through the opening in the carrier (above the ribbon cable).
- Step 4. Connect the REG P25 connector to the J25 terminal on the Regulator board. See figure 2.3.
- Step 5. Slide the Regulator board back into place and secure it with its mounting screws.
- Step 6. Reinstall the OIM/DCM.

4.5 Reinstalling the OIM Carrier and Cover

- Step 1. Swing the mounting panel back into the closed position, and secure it by twisting the notches on the two plastic anchors into a horizontal position.
- Step 2. Close the OIM carrier and secure it in place with its captive screw.
- Step 3. Reinstall the OIM/DCM cover.

4.6 Replacing the Drive Fuses

- Step 1. Locate the fuse block on the drive's line fuse panel. See figure 4.2.
- Step 2. Remove the three fuses labeled 6FU, 7FU, and 8FU from the fuse block.
- Step 3. Install the three provided 25 Amp, 600 Volt fuses (P/N 65676-30M) in the fuse block in positions 6FU, 7FU, and 8FU.

4.7 Reinstalling the Drive Cover

- Step 1. Reinstall the cover over the right side of the drive.
- Step 2. Reinstall the plastic cover over the drive's line fuse panel. Hardware installation is complete.
- Step 3. Reconnect power to the drive.
- Step 4. Remove the lockout and tag.
- Step 5. Turn on power to the drive.

4.8 Modifying the Drive Configuration

Go to chapter 5 for information on setting parameters for the Field Current Regulator kit.

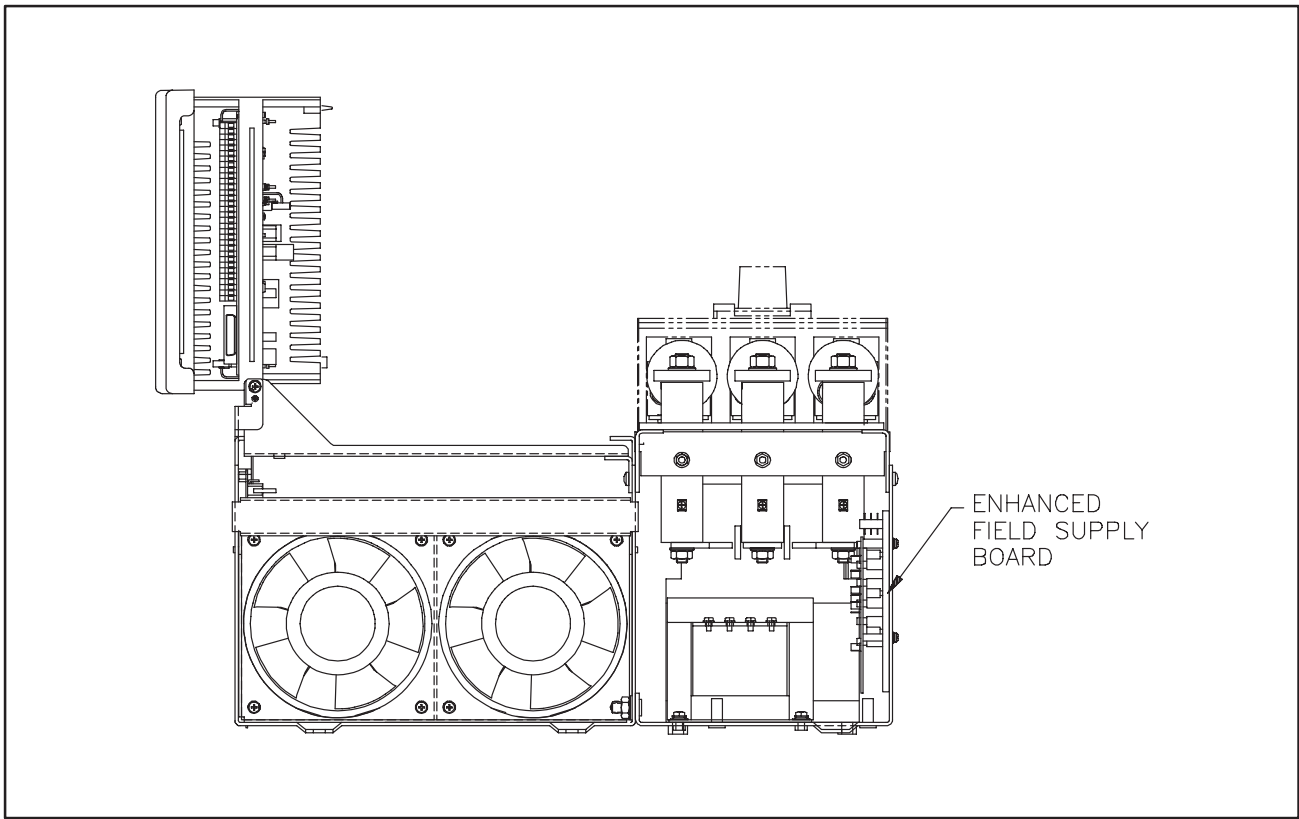

Figure 4.1 - Removing the Standard/Enhanced Field Supply (200 - 300 HP Drives)

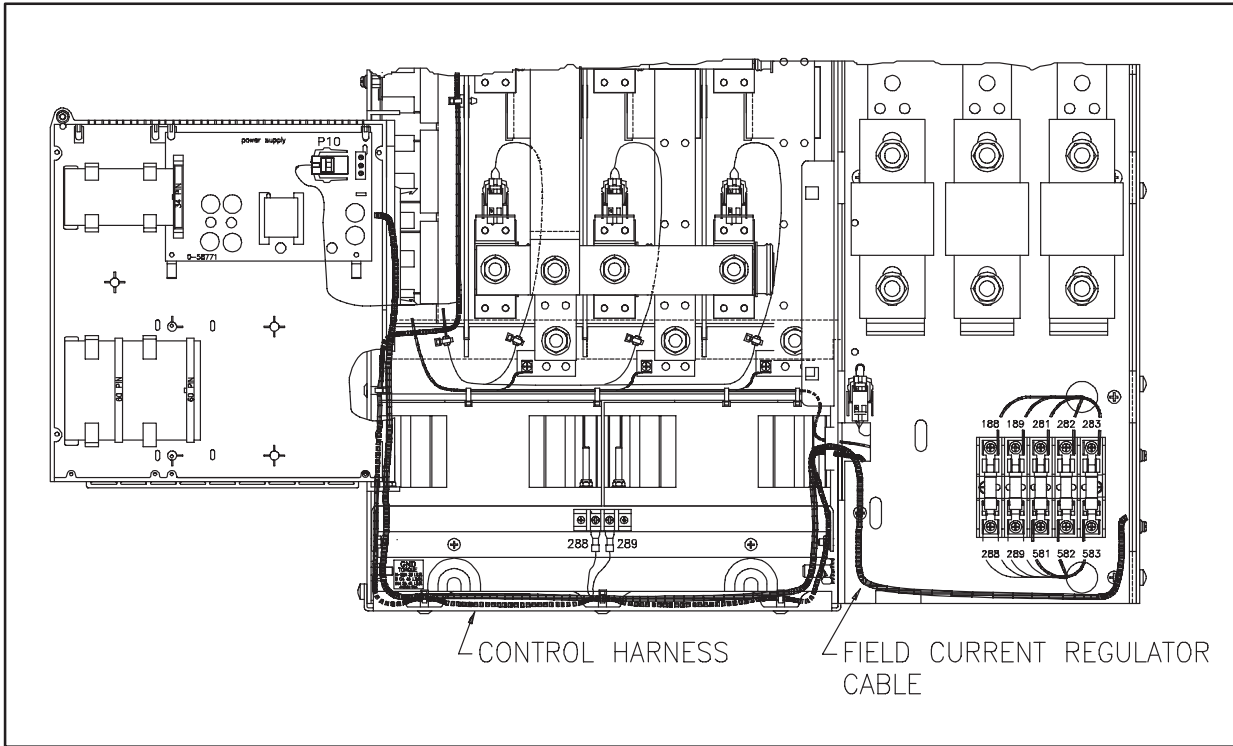

Figure 4.2 - Cable Routing (200 - 300 HP Drives)

5.0 MODIFYING THE DRIVE CONFIGURATION

Before you can use the Field Current Regulator kit, you must set the parameters listed below in the FlexPak 3000 drive. These parameters are described in sections 5.1 and 5.2.

- Parameter 510 (MOTOR HOT FLD AMPS)
- Parameter 511 (FIELD ECONOMY REF)

In addition, the input parameters listed below may need to be adjusted in order to tune the field control loop. Refer to your drive's instruction manual for a complete description of these parameters.

- Parameter 501 (FIELD ECONOMY DELAY)
- Parameter 512 (FIELD LOSS THRESHOLD)
- Parameter 513 (FIELD REF REGISTER)
- Parameter 514 (FIELD PI PROP GAIN)
- Parameter 515 (FIELD PI LEAD FREQ)
- Parameter 516 (FLD FEEDBACK GAIN ADJ)
- Parameter 517 (FIELD AUTO WEAKEN)
- Parameter 518 (FLD WEAKEN THRESHOLD)
- Parameter 519 (FLD WEAKEN PROP GAIN)
- Parameter 520 (FLD WEAKEN LEAD FREQ)
- Parameter 587 (FIELD DELTA HIGH LIM)

Once the Field Current Regulator kit is installed and the drive is configured, the following output parameters can be used. Refer to your drive instruction manual for complete descriptions of these output parameters.

- Parameter 586 (FLD CURRENT REGULATOR)
- Parameter 588 (FIELD DELTA)
- Parameter 589 (FIELD FEEDBACK)
- Parameter 590 (FIELD REFERENCE)

If you are installing and setting up the Field Current Regulator kit as part of your initial drive setup, and are using the quick start procedure described in the drive's instruction manual, you will be prompted for parameter 510 (MOTOR HOT FLD AMPS). In this case, after you finish with the quick start procedure, make sure that you set parameter 511 (FIELD ECONOMY REF).

If you are installing and setting up the Field Current Regulator kit after you have already set up the drive, you do not need to rerun the quick start procedure. Simply access the parameters and set the values as described in sections 5.1 and 5.2.

5.1 Setting Parameter 510 (MOTOR HOT FLD AMPS)

When the drive is first powered up after installing the Field Current Regulator, the Field Current Regulator will operate in a fixed voltage mode until a valid value is entered for MOTOR HOT FLD AMPS. This fixed voltage will produce 150 VDC on a 230 VAC line or 300 VDC on a 460 VAC line. If your motor field voltage is significantly less than this, begin with step 1. Otherwise, begin with step 7 if your drive is equipped with an OIM, or step 18 if your drive is equipped with a DCM.

If the motor field voltage is less than 150 VDC on a 230 VAC line or less than 300 VDC on a 460 VAC line, complete steps 1-6 first. Otherwise, go to step 9.

Step 1. Disconnect, tag, and lockout power to the drive.

Step 2. Disconnect the motor field winding from the drive.

- Step 3. Reconnect power to the drive.
- Step 4. Remove the lockout and tag.
- Step 5. Turn on power to the drive.
- Step 6. After completing power-up diagnostics, the drive will generate a field current loss fault. Ignore this fault.
- Step 7. Access the Fault menu by pressing the FAULT key until FAULT appears on the OIM directly above the FAULT key.
- Step 8. Select Clear Fault Log and Reset Faults, and then press ENTER. The fault log will be cleared and all drive faults will be reset.

If the drive is equipped with an OIM, complete the following steps to set MOTOR HOT FLD AMPS. Otherwise, go to step 18.

- Step 9. Select MOTOR HOT FLD AMPS by taking the following path from the main menu:

```

Field
├── Field Current Regulator
│   └── Field Loop Feedback Scaling

```

- Step 10. Set MOTOR HOT FLD AMPS to the value printed on the motor nameplate.

- Step 11. Select MEMORY SAVE by taking the following path from the main menu:

```

Operator Interface
├── Memory Operations

```

- Step 12. Perform the Memory Save operation.

If the motor field winding was disconnected in step 2 above, perform steps 13-17. Otherwise, go to step 18.

- Step 13. Disconnect, tag, and lockout power to the drive.
- Step 14. Reconnect the motor field winding to the drive.
- Step 15. Reconnect power to the drive.
- Step 16. Remove the lockout and tag.
- Step 17. Turn on power to the drive.
- Step 18. Access the Fault menu by pressing the FAULT key until FAULT appears on the OIM directly above the FAULT key.
- Step 19. Select Clear Fault Log and Reset Faults, and then press ENTER. The fault log will be cleared and all drive faults will be reset. If you have an OIM, you are done with setting parameter 510. Go to section 5.1 to set parameter 511 (FIELD ECONOMY REF).

NOTE: Performing a Restore Defaults operation will cause the Field Current Regulator to re-enter the fixed voltage mode of operation and require the re-execution of the above steps.

If the drive is equipped with a DCM, use the following steps to set MOTOR HOT FLD AMPS.

- Step 20. From the main menu, scroll to Input Parameters and press ENTER.
- Step 21. Scroll to HOT FLD AMPS.
- Step 22. Set HOT FLD AMPS to the value printed on the motor nameplate.
- Step 23. From the main menu, scroll to Memory Operations and press ENTER.
- Step 24. Scroll to Memory Save, and then perform the memory save operation.

If the motor field winding was disconnected in step 2 above, perform steps 25-29. Otherwise, proceed to step 30.

- Step 25. Disconnect, tag, and lockout power to the drive.

- Step 26. Reconnect the motor field winding to the drive.
- Step 27. Reconnect power to the drive
- Step 28. Remove the lockout and tag.
- Step 29. Turn on power the drive.
- Step 30. Access the Fault menu and press ENTER.
- Step 31. Scroll to Clear Fault Log and Reset Faults, and then press ENTER. The fault log will be cleared and all drive faults will be reset.

NOTE: Performing a Restore Defaults operation will cause the Field Current Regulator to re-enter the fixed voltage mode of operation and require the re-execution of the above steps.

5.2 Setting Parameter 511 (FIELD ECONOMY REF)

WARNING

IMPROPER SETTING OF THE FIELD ECONOMY REF PARAMETER CAN CAUSE A MOTOR OVERVOLTAGE CONDITION. SET THE MOTOR HOT FLD AMPS PARAMETER TO THE MOTOR'S NAMEPLATE VALUE. MAKE SURE THE FIELD ECONOMY REF PARAMETER AND/OR FIELD REF PARAMETER (P.513) ARE ABOVE THE FIELD LOSS THRESHOLD PARAMETER (P.512). FAILURE TO OBSERVE THIS PRECAUTION COULD RESULT IN BODILY INJURY AND DAMAGE TO THE EQUIPMENT.

For proper drive operation, the value for parameter 511 (FIELD ECONOMY REF) must be set above the value for parameter 512 (FIELD LOSS THRESHOLD). Note that the default value for FIELD ECONOMY REF is 0% and that the default value for FIELD LOSS THRESHOLD is 60% of MOTOR HOT FLD AMPS. Using the defaults for parameters 511 and 512 will result in a drive default.

See your drive's manual for more information on setting the FIELD LOSS THRESHOLD parameter properly. Then complete the following steps.

If the drive is equipped with an OIM, complete steps 1-6. If the drive is equipped with a DCM, skip to step 7.

Step 1. Select FIELD LOSS THRESHOLD by taking the following path from the main menu:

```

Field
├── Field Current Regulator
│   └── Field Loop Configure
    
```

Step 2. Note the value of FIELD LOSS THRESHOLD.

Step 3. Back up to the Field Loop Configure menu and select FIELD ECONOMY REF.

Step 4. Set the value of FIELD ECONOMY REF to a value higher than that of FIELD LOSS THRESHOLD.

Step 5. Select MEMORY SAVE by taking the following path from the main menu:

```

Operator Interface
├── Memory Operations
    
```

Step 6. Perform the Memory Save operation.

If the drive is equipped with a DCM, complete the following steps:

Step 7. From the main menu, scroll to Input Parameters and press ENTER.

Step 8. Scroll to FIELD LOSS THRESHOLD and note its value.

Step 9. Scroll to FIELD ECONOMY REF.

Step 10. Set the value of FIELD ECONOMY REF to a value higher than that of FIELD LOSS THRESHOLD.

Step 11. From the main menu, scroll to Memory Operations and press ENTER.

Step 12. Scroll to Memory Save, and then perform the memory save operation.

The installation procedure for the Field Current Regulator kit is now complete.

Appendix A

Field Current Regulator Description

Description of the Field Control Loop

The FlexPak 3000 version 3 regulator will detect the presence of the Field Current Regulator kit at power-up. The output parameter FLD CURRENT REGULATOR indicates whether or not the Field Current Regulator kit is installed. When the Field Current Regulator kit is installed, the field current control loop operates and drive parameters ENHANCED FLD VOLT ADJ and J21 FLD SUPPLY JUMPER are ignored. The regulated field loss and field economy circuits become active in place of those used by the standard and enhanced field supplies. See figure A.1 for a block diagram of the field control loop.

NOTE: The regulator board jumper J20 (Field Loss Detect) is ignored when the Field Current Regulator is installed. Therefore, setting J20 to the DISABLE position will NOT disable field loss detection.

The field control loop contains two regulators: a field current regulator and an armature voltage (counter-EMF or CEMF) regulator. The field control loop can be configured to decrease armature voltage when the armature voltage feedback (ARMATURE VOLTAGE) exceeds the FLD WEAKEN THRESHOLD voltage and the field begins to weaken (see figures A.1 and A.2). The armature IR drop can be compensated for by using the IR COMPENSATION parameter (P.206).

The output of the Field Current Regulator determines the firing angle of the regulated field supply gate firing circuit. The output parameter FIELD DELTA represents the angle in degrees. If the factory defaults for the Field Current Regulator are in effect, it will operate in a fixed voltage mode by firing the field SCRs at a fixed angle of 117°. This will produce a field voltage of 150 VDC at 230 VAC line input or 300 VDC at 460 VAC line input. For other motor field voltages, MOTOR HOT FLD AMPS must be set properly before the motor field is connected. While the Field Current Regulator is producing fixed voltage, the value for MOTOR HOT FLD AMPS will be set to 0.01 amps. After a valid value is entered for MOTOR HOT FLD AMPS, the user-assigned value for FIELD LOSS THRESHOLD becomes effective. The Field Current Regulator will NOT regulate field current until a valid value for MOTOR HOT FLD AMPS is entered. While in fixed voltage mode, a field loss fault will only occur if there is a complete loss of field current. This is similar to having a standard or enhanced field supply installed.

CAUTION: If the factory defaults for the Field Current Regulator are not in effect (e.g., MOTOR HOT FLD AMPS was modified via the network or CS3000), extreme care must be exercised to ensure the correct value for MOTOR HOT FLD AMPS is present when power is applied to the drive. Failure to observe this precaution could result in damage to, or destruction of, the equipment.

Both field loop regulators contain proportional plus integral (PI) control. There is no user-configurable low limit parameter associated with these PI blocks. The low limit is always fixed at zero. The high limit (FIELD DELTA HI LIM) is user-configurable up to 180 degrees, allowing full-on field voltage of 207 VDC @ 230 VAC and 414 VDC @ 460 VAC. To regulate greater field voltages, a step-up transformer must be used to supply the AC side of the Field Current Regulator.

As the motor speed increases beyond base speed, the armature voltage will increase above rated voltage. The PI block monitoring armature voltage will reduce the high limit of the PI block controlling field current. As field current decreases, field flux and armature voltage will also decrease. Field current continues to decrease until armature voltage is reduced to FLD WEAKEN THRESHOLD volts. Control of armature voltage during field weakening is only permitted when a tachometer is used (FEEDBACK SELECT ≠ ARMATURE VOLTS). Automatic field weakening can be disabled by setting FIELD AUTO WEAKEN = DISABLED. The drive can also be operated in the constant power (field control) range by controlling the field current reference exclusively (FIELD REF REGISTER).

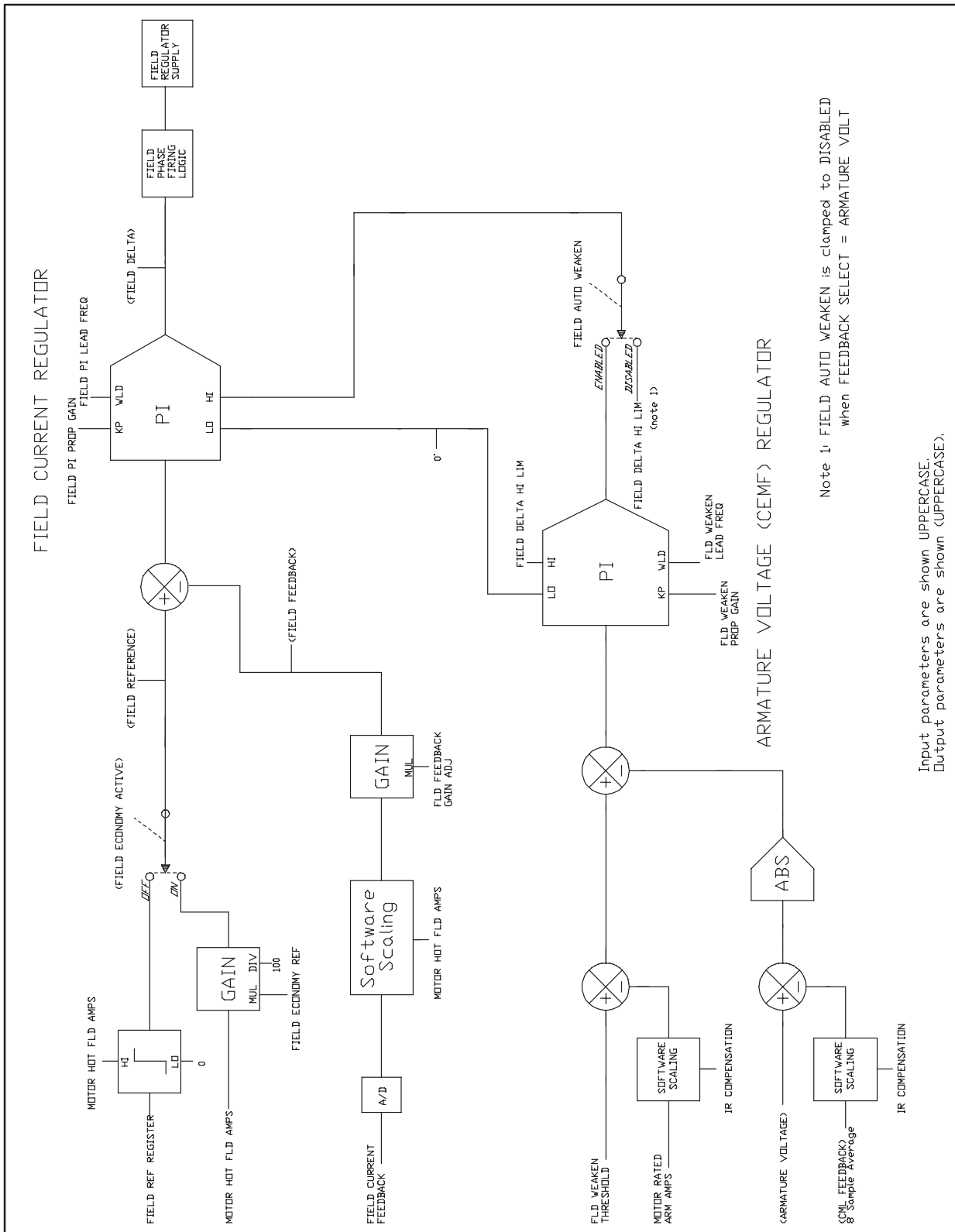

Figure A.1 - Field Control Loop

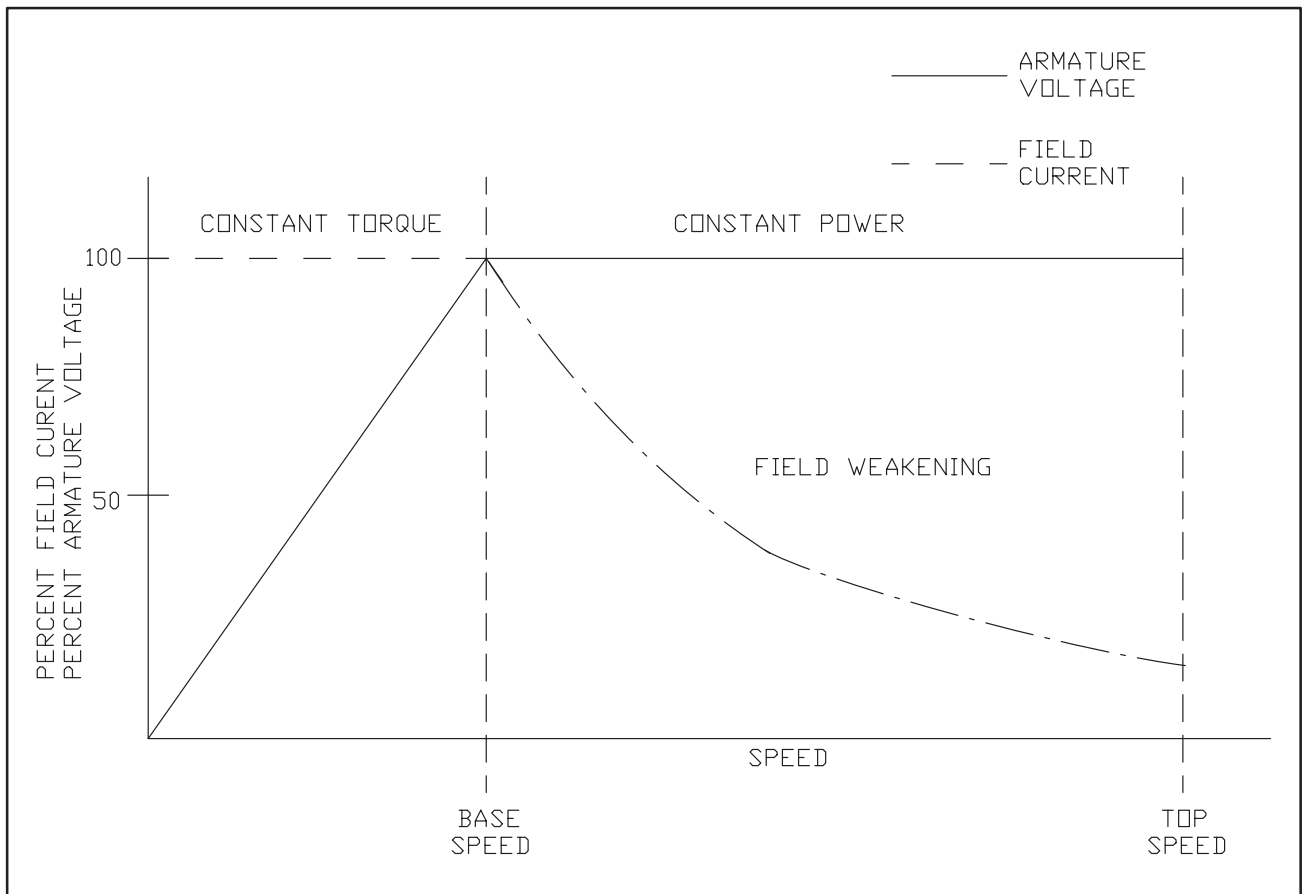

Figure A.2 - Drive Operation Over the Constant Torque and Constant Power Range

Field Current Feedback Scaling

There are three Field Current Regulator ratings: 4 amps, 10 amps, and 15 amps. The Regulator board hardware provides three different gains for the field current feedback signal: 1, 2, and 5. The user must enter the motor nameplate value for rated field amps (MOTOR HOT FLD AMPS) to properly scale the feedback signal. The software will automatically select the feedback gain (in hardware) which produces the largest full scale digital value in the analog-to-digital converter. MOTOR HOT FLD AMPS will be limited based on the rating of the Field Current Regulator kit installed. Table A.1 shows what the software will select as the feedback gain depending on motor hot field amps.

Table A.1 - Field Current Feedback Scaling

Field Current Rating (Amps)	Motor Hot FLD Amps	Gain	Rated Output (Amps)	Field Current Resolution (milliamps)
4	0.11 to 0.8	5	0.8	4
	0.81 to 2.00	2	2	10
	2.01 to 4.00	1	4	20
10	0.28 to 2.00	5	2	10
	2.01 to 5.00	2	5	25
	5.01 to 10.00	1	10	50
15	0.55 to 4.00	5	4	20
	4.01 to 10.00	2	10	50
	10.01 to 20.00	1	15	100

Field Loss

When the Field Current Regulator is operating in fixed voltage mode, a field current loss fault will be generated only when there is a complete loss of field current. When the Field Current Regulator is regulating field current (that is, not in fixed voltage mode), a field current loss fault will be generated when the field current drops below the user-set FIELD LOSS THRESHOLD.

The same field feedback signal used by the Field Current Regulator is used by the field loss detection circuit. The field current feedback will be compared against a user-entered FIELD LOSS THRESHOLD. If the feedback is less than the threshold value, a fault will be generated. FIELD LOSS THRESHOLD is entered as a percentage of

MOTOR HOT FLD AMPS (0-100% (speed regulator), 50-100% (armature voltage regulator)). FIELD ECONOMY REF must be set above FIELD LOSS THRESHOLD to avoid field loss faults when the drive enters field economy.

A field loss fault will also occur if the digital value on the A/D converter reaches full scale (approximately 28% above the rated field output).

The regulator board hardware jumper, J20 Field Loss Detect, is designed to allow the user to separately excite the motor field winding, and is not intended as a means of bypassing field loss detection when using an internal field supply. Therefore, when the Field Current Regulator kit is installed, this jumper is ignored. Note that leaving J20 in the DISABLE position will NOT disable field loss detection.

Field Economy

The output parameter FIELD ECONOMY ACTIVE indicates when field economy is active. Field economy becomes active after a user-defined time delay (FIELD ECONOMY DELAY) from the time the motor stops or the drive is powered up. When the Field Current Regulator is operating in fixed voltage mode, a constant field voltage is generated, regardless of the state of FIELD ECONOMY ACTIVE.

The Field Current Regulator will provide field economy with a user-adjustable field current reference (FIELD ECONOMY REF). This parameter is entered as a percentage of MOTOR HOT FLD AMPS. FIELD ECONOMY REF must be set above FIELD LOSS THRESHOLD to avoid nuisance field loss faults.

Overspeed Protection

Overspeed detection is active only when a tachometer is being used (FEEDBACK SELECT \neq ARMATURE VOLT). Because of this, the amount of field weakening is limited when the drive is configured as a voltage regulator (FEEDBACK SELECT = ARMATURE VOLT).

Overvoltage Protection

Armature overvoltage protection is always active, regardless of the type of feedback. This will reduce the chance of overvolutaging the armature due to a weakened field. An overvoltage fault will occur when the armature terminal voltage exceeds 130 percent of MOTOR RATED ARM VOLTS.

Reliance Electric / 24703 Euclid Avenue / Cleveland, Ohio 44117 / (216) 266-7000

