

PRACTICALITY & PERFORMANCE

Reliability, dependability, and great value are built into the FH4B Fan Units. The unit is compact and easy to install, with capacities ranging from 800 to 2000 CFM. The units are the right choice if you need versatility and affordability in a fan unit.

These fan coil units offer an air handler for practical, no-nonsense application and outstanding performance. The multipoise units allow greater flexibility to meet your upflow, downflow, or horizontal installation requirements, and offer multiple electric entry to permit quick, hassle-free hookup (003 and 004 when coupled with coil are upflow/downflow only). All models come fully equipped with solid-state cooling controls.

The FH4B, with its 3-speed motor and field-installed heater package, provides the application versatility required for most installations. Heater packages are available from 3- through 30-kw, either fused or with a circuit breaker, or non-fused for 10-kw and less.

FEATURES

- Prepainted galvanized sheet metal
- Cooling controls with every unit
- 3-speed motor
- Unique cabinet design to meet air leakages regulations
- Factory-supplied cleanable filter
- Easy access filter for cleaning—no tools required
- Air sealed filter door
- Field-installed heater packages 3- through 30-kw, fused, circuit breaker, non-fused (10-kw and down)
- Factory-supplied power plug
- Control board with replaceable 5-amp blade type auto fuse
- Foil-faced high-density super thick R-4.2 insulation
- Multiple electric entry
- HUD approved for manufactured housing
- 40-va, 208/230-v transformer
- All models listed with UL (U.S. and Canada) and ARI

MODEL NUMBER NOMENCLATURE

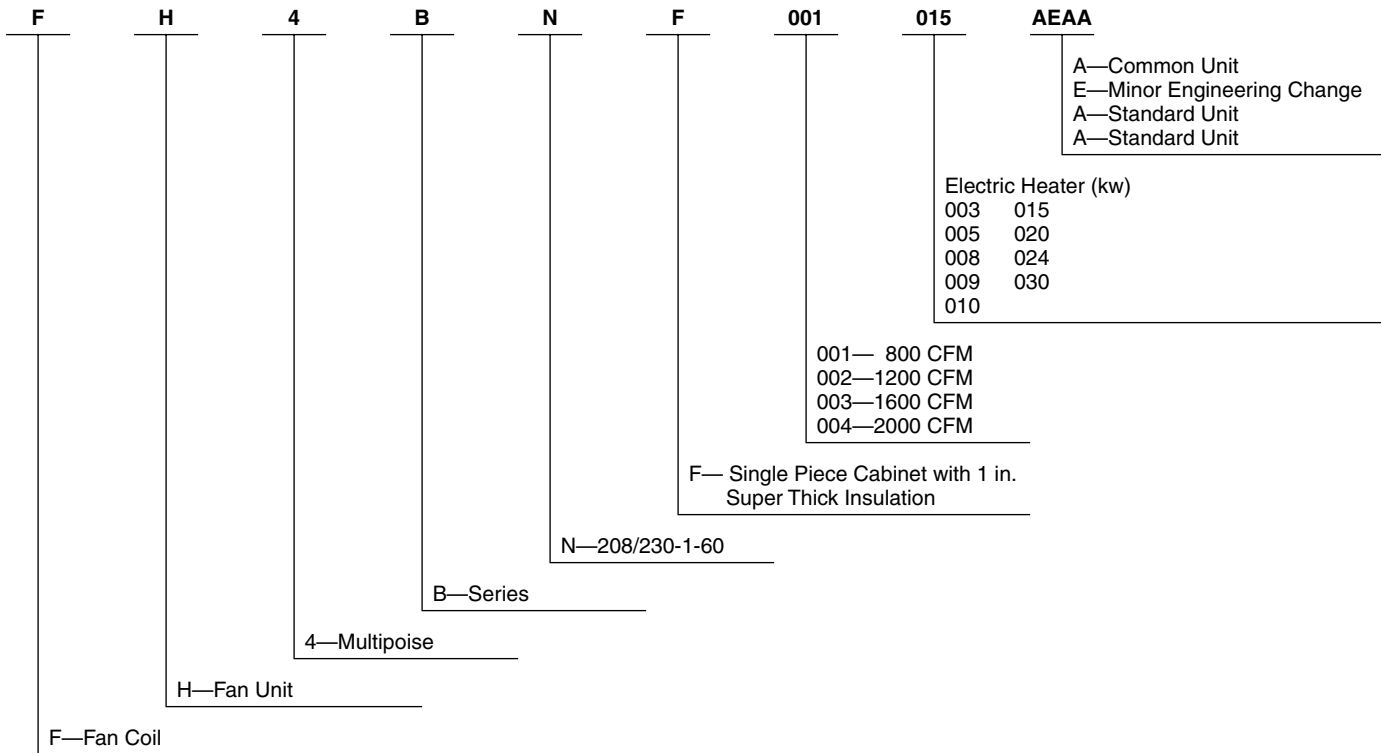

CERTIFICATION APPLIES ONLY WHEN THE COMPLETE SYSTEM IS LISTED WITH ARI.

REGISTERED
QUALITY
SYSTEM

DIMENSIONS

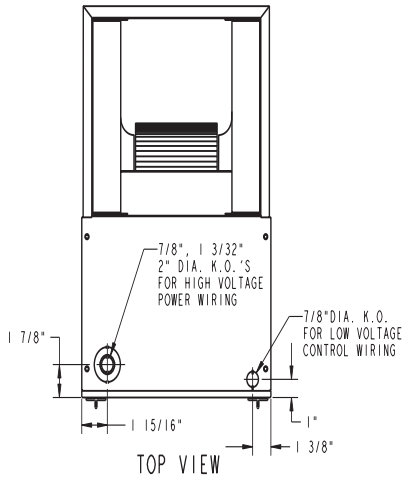

NOTE:

1. SERIES DESIGNATION IS THE 14TH POSITION OF UNIT PRODUCT NUMBER.

NOTE: ALLOW 21" FROM FRONT FOR SERVICE

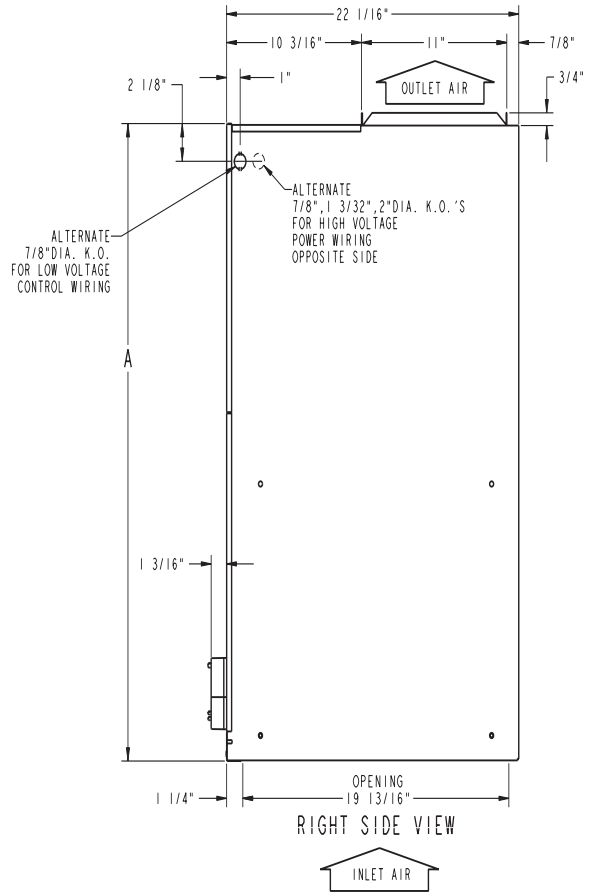
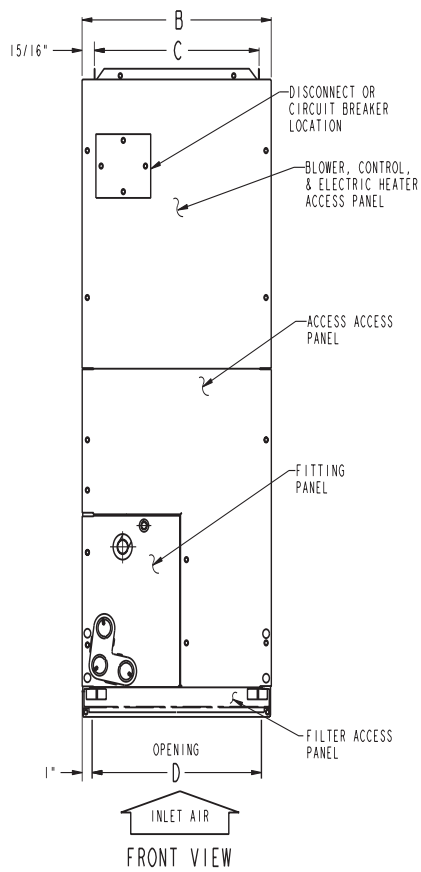

A02300

UNIT	SERIES	A	B	C	F	ACCY. COIL CONFIGURATION		OPERATING WEIGHT (Lb)
		In.	In.	In.	In.	SLOPE	"A"	
FH4BNF001	E	42-11/16	14-5/16	12-7/16	12-5/16	✓		75
FH4BNF002	E	49-5/8	17-5/8	15-3/4	15-5/8	✓		92
FH4BNF003	E	49-5/8	21-1/8	19-1/4	19-1/8		✓	106
FH4BNF004	E	53-7/16	21-1/8	19-1/4	19-1/8		✓	114.5

DIMENSIONS Continued

- HORIZONTAL MOUNT LOCATIONS - DIMPLES PROVIDED IN TOP PANEL, AND BACK OF CABINET. IN CABINET BOTTOM, HOLES PROVIDED .136" DIA. HORIZONTAL HANGING HARDWARE TO BE FIELD SUPPLIED.

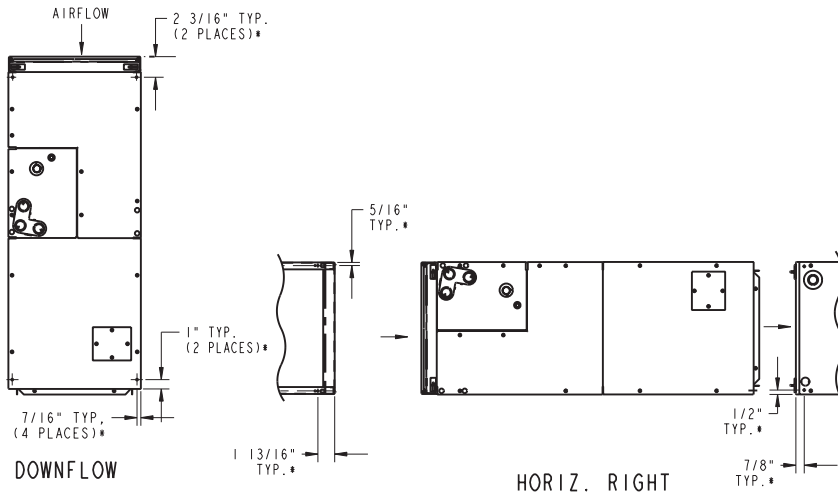
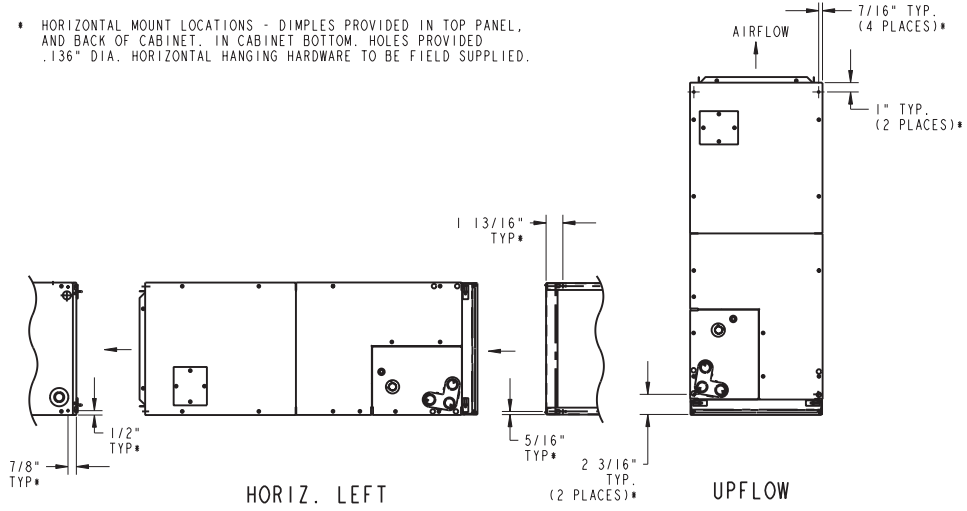

A02301

DIMENSIONS Continued

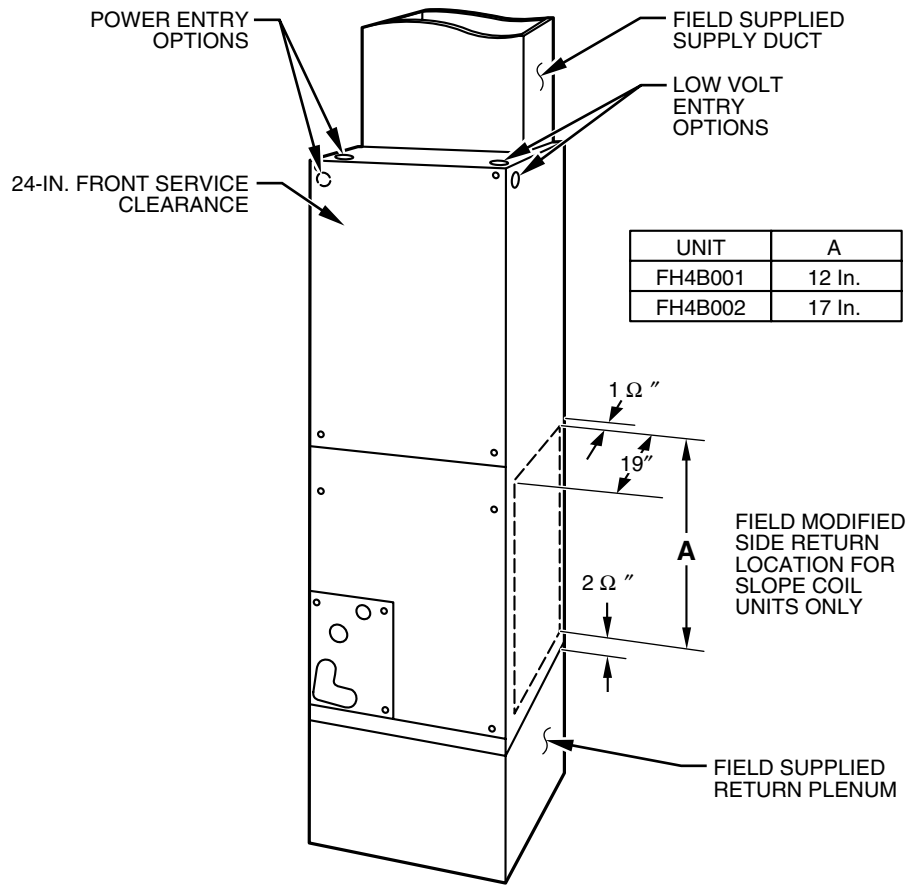

A02294

*Side Return not compatible when used in conjunction with accessory cooling coil

Field-modified Side Return Location For Slope Coils Only

SPECIFICATIONS

UNIT SIZE	001	002	003	004
FAN Air Discharge CFM (Nominal) Motor Hp (PSC)	850 1/4	1300 1/3	1700 3/4	2000 3/4
FILTER	21-1/2 x 13	21-1/2 x 16-3/8	21-1/2 x 19-7/8	

AIRFLOW PERFORMANCE* (CFM)

SIZE	BLOWER SPEED	EXTERNAL STATIC PRESSURE (IN. WC)											
		0.10		0.20		0.30		0.40		0.50		0.60	
		208	230	208	230	208	230	208	230	208	230	208	230
FH4B001	HIGH	1173	1270	1135	1225	1090	1170	1045	1126	993	1058	925	981
	MED	900	1025	875	991	847	963	810	922	768	869	695	802
	LOW	579	687	560	663	537	639	505	610	451	554	384	467
FH4B002	HIGH	1630	1841	1605	1798	1567	1748	1525	1696	1480	1629	1415	1560
	MED	1244	1438	1225	1407	1190	1383	1170	1342	1141	1308	1100	1265
	LOW	1001	1172	985	1147	955	1116	930	1094	908	1062	850	1024
FH4B003	HIGH	—	—	—	—	2118	—	2060	2202	1949	2106	1853	1989
	MED	1757	2061	1745	2016	1734	1985	1716	1943	1686	1890	1624	1802
	LOW	1290	1535	1286	1535	1281	1528	1277	1515	1263	1467	1245	1431
FH4B004	HIGH	—	—	—	—	2257	—	2235	—	2188	—	2113	2336
	MED	—	—	1930	2215	1914	2196	1887	2163	1838	2106	1787	2047
	LOW	1620	1881	1620	1870	1613	1864	1607	1853	1594	1836	1562	1802

* With factory approved filter, 10-kw elec heat 001 and 002 sizes, 15-kw elec heat 003 and 004 sizes 230-volt.

AIRFLOW PERFORMANCE WITH ACCESSORY COIL (CFM)

MODEL AND SIZE	BLOWER MOTOR SPEED	TOTAL EXTERNAL STATIC PRESSURE (IN. WC)											
		0.10		0.20		0.30		0.40		0.50		0.60	
		208	230	208	230	208	230	208	230	208	230	208	230
FH4B001 WITH KFAEC0501024	HIGH	945	975	900	930	840	870	780	805	695	725	560	595
	MED	835	900	795	855	745	800	690	740	610	650	470	510
	LOW	605	695	575	665	530	625	485	580	425	510	340	395
FH4B002 WITH KFAEC0601036	HIGH	1485	1550	1425	1490	1365	1420	1300	1350	1230	1275	1150	1190
	MED	1235	1380	1200	1325	1160	1265	1110	1210	1055	1140	985	1070
	LOW	1035	1185	1010	1150	980	1115	940	1070	890	1010	825	935
FH4B003 WITH KFAEC0301048	HIGH	1880	1935	1785	1830	1700	1735	1615	1645	1520	1555	1430	1460
	MED	1740	1840	1660	1750	1585	1660	1510	1575	1435	1485	1350	1390
	LOW	1425	1605	1395	1555	1360	1495	1315	1430	1255	1360	1170	1270
FH4B004 WITH KFAEC0401060	HIGH	2145	2245	2085	2185	2030	2115	1965	2045	1905	1975	1830	1895
	MED	2025	2175	1970	2110	1915	2050	1860	1990	1805	1905	1740	1830
	LOW	1680	1895	1655	1855	1625	1810	1595	1765	1555	1705	1500	1645

- NOTES:**
- Airflow based upon dry coil at 230v with factory approved accessory filter and electric heater (10-kw electric heat, sizes 001 and 002; 15-kw electric heat, sizes 003 and 004).
 - To avoid potential for condensate blowing out of drain pan prior to making drain trap:
 - Return static pressure must be less than 0.4 in. wc
 - Horizontal applications of 048-070 sizes must have supply static greater than 0.20 in. wc
- Airflow outside max ARI airflow of 450 cfm/ton on 018-154 sizes
Airflow above 400 cfm/ton on 060-070 sizes. Airflows in this region could result in condensate blowing off coil or splashing out of drain pan.

FILTER STATIC PRESSURE DROP (IN. WC)

UNIT SIZE	CFM									
	400	600	800	1000	1200	1400	1600	1800	2000	
001	—	0.044	0.075	0.110	—	—	—	—	—	
002	—	—	—	0.072	0.100	0.130	—	—	—	
003	—	—	—	—	—	0.092	0.120	0.152	—	
004	—	—	—	—	—	—	0.120	0.152	0.187	

FAN COIL ELECTRICAL DATA (UNITS WITHOUT ELECTRICAL HEAT)

UNIT SIZE	VOLTS (1 PHASE)	FLA	MIN CKT AMPS	BRANCH CIRCUIT	
				Min Wire Size AWG*	Fuse Amps
001	208/230	1.8	2.3	14	15
002	208/230	2.7	3.4	14	15
003	208/230	4.3	5.4	14	15
004	208/230	5.4	6.8	14	15

* Use copper wire only. 75°C must be used in this application. When using non-metallic (NM) sheathed cable, wire size required should be based on that of 60°C conductors, instead of wire sizes shown in table above per NEC 1999 Article 336-26.

FLA — Full Load Amps

NOTE: If branch circuit wire length exceeds 100 ft., consult NEC 215-2 to determine maximum wire length. Use 2% voltage drop.

ELECTRIC HEATER INTERNAL PROTECTION*

HEATER KW	PHASE	FUSES QTY/SIZE	CKT BKR QTY/SIZE†
3	1	—	—
5	1	—	1/60
8	1	—	1/60
10	1	—	1/60
15	1	2/30 – 2/60	2/60
20	1	4/60	2/60
24	3/1	6/60	—
30	3/1	6/60	—
9	1/3**	—	—
15	3	—	—
18	3	—	—

* 5-, 8-, 10-kw factory-installed heat has no internal protection. 15-kw factory-installed heat is internally protected with fuses.

** KFCEH1401N09 is single phase only.

† Circuit breakers are 2 pole.

ELECTRIC HEATERS

HEATER PART NO.	KW @ 240V	VOLTS/PHASE	STAGES (KW OPERATING)	INTERNAL CIRCUIT PROTECTION	FAN COIL SIZE USED WITH	HEATING CAP. ** @ 230V
KFCEH0401N03	3	230/1	3	None	001	9,400
KFCEH0501N05	5	230/1	5	None	001, 002	15,700
KFCEH0801N08	8	230/1	8	None	001–004	25,100
KFCEH0901N10	10	230/1	10	None	001–004	31,400
KFCEH3201F20	20	230/1	5, 20	Fuse†	002–004	62,800
KFCEH1601315	15	230/3	5, 15	None	002–004	47,100
KFCEH2001318	18	230/3	6, 12, 18	None	003, 004	56,500
KFCEH3401F24	24	230/3*	8, 16, 24	Fuse	003, 004	75,300
KFCEH3501F30	30	230/3*	10, 20, 30	Fuse	003, 004	94,100
KFCEH2401C05	5	230/1	5	Circuit Breaker	001, 002	15,700
KFCEH2501C08	8	230/1	8	Circuit Breaker	001, 002	25,100
KFCEH2601C10	10	230/1	10	Circuit Breaker	001–004	31,400
KFCEH3301C20	20	230/1	5, 20	Circuit Breaker	002–004	62,800
KFCEH2901N09	9	230/1†	3, 9	None	002–004	28,200
KFCEH3001F15	15	230/1	5, 15	Fuse†	001–004	47,100
KFCEH3101C15	15	230/1	5, 15	Circuit Breaker	001–004	47,100

SMART HEAT

HEATER PART NO.	KW @ 240V	VOLTS/PHASE	STAGES (KW OPERATING)	INTERNAL CIRCUIT PROTECTION	FAN COIL SIZE USED WITH	HEATING CAP. ** @ 230V
KFCEH0101H10	10	230/1	3, 6, 9	None‡	001, 002	31,400
KFCEH0201H15	15	230/1	3, 8, 11, 15	Fuse	001-003	47,100
KFCEH0301H20	20	230/1	5, 10, 15, 20	Fuse	002-004	62,800

* Field convertible to 1 phase.

† KFAEH2501N09 is field convertible to 3 phase.

‡ Single point wiring kit required for these heaters in Canada.

** Blower motor heat not included.

When using units with 20-, 24-, and 30-kw electric heaters, maintain a 1-in. clearance from combustible materials to discharge plenum and ductwork, and maintain a distance of 36 in. from the unit. Use an accessory downflow base to maintain proper clearance on downflow installations.

Use flexible connectors between ductwork and unit to prevent transmission of vibration. When electric heater is installed, use heat resistant material for flexible connector between ductwork and unit at discharge connection. Ductwork passing through unconditioned space must be insulated and covered with vapor barrier.

ESTIMATED SOUND POWER LEVEL (dBA)

UNIT SIZE	CONDITIONS		OCTAVE BAND CENTER FREQUENCY*						
	CFM	Ext Static Pressure	63	125	250	500	1000	2000	4000
FH4-001	800	0.25	66.0	62.0	58.0	55.0	53.0	51.0	47.0
FH4-002	1200	0.25	67.8	63.8	59.8	56.8	54.8	52.8	48.8
FH4-003	1600	0.25	69.0	65.0	61.0	58.0	56.0	54.0	50.0
FH4-004	2000	0.25	70.0	66.0	62.0	59.0	57.0	55.0	51.0

* Estimated sound power levels have been derived using the method described in the *1987 ASHRAE HVAC Systems & Applications Handbook*, Chapter 52, p. 52.7

ELECTRIC HEATER ELECTRICAL DATA

HEATER PART NO.	KW	PHASE	INTERNAL CIRCUIT PROTECTION	HEATER AMPS 208/230V			BRANCH CIRCUIT						Max Fuse/Ckt Brk Amps 208/230V			Max Wire Length 208/230V (FT)†			
				Single Circuit	Dual Circuit		Min Wire Size (AWG) 208/230V††		Min Gnd Wire Size 208/230V		Single Circuit	Dual Circuit		Single Circuit	Dual Circuit		Single Circuit	Dual Circuit	
					L1,L2	L3,L4	L1,L2	L3,L4	L1,L2	L3,L4		L1,L2	L3,L4		L1,L2	L3,L4		L1,L2	L3,L4
KFCEH0401N03	3	2,3	1	None	10.9/12.0	—	—	12/12	—	—	12/12	—	—	20/20	—	—	67/68	—	—
KFCEH0501N05 ¹	5	3,8	1	None	18.1/20.0	—	—	10/10	—	—	10/10	—	—	30/30	—	—	66/66	—	—
KFCEH0501N05 ²	5	3,8	1	None	18.1/20.0	—	—	8/8	—	—	10/10	—	—	35/35	—	—	85/88	—	—
KFCEH2401C05 ¹	5	3,8	1	Ckt Bkr	18.1/20.0	—	—	10/10	—	—	10/10	—	—	30/30	—	—	66/66	—	—
KFCEH2401C05 ²	5	3,8	1	Ckt Bkr	18.1/20.0	—	—	8/8	—	—	10/10	—	—	35/35	—	—	85/88	—	—
KFCEH0801N08	8	6,0	1	None	28.9/32.0	—	—	8/8	—	—	10/10	—	—	45/50	—	—	59/60	—	—
KFCEH2501C08	8	6,0	1	Ckt Bkr	28.9/32.0	—	—	8/8	—	—	10/10	—	—	45/50	—	—	59/60	—	—
KFCEH2901N09***	9	6,8	1	None	32.8/36.0	—	—	8/6	—	—	10/10	—	—	50/60	—	—	54/87	—	—
—	9	6,8	3	None	18.8/20.8	—	—	8/8	—	—	10/10	—	—	35/35	—	—	83/85	—	—
KFCEH0901N10	10	7,5	1	None	36.2/40.0	—	—	6/6	—	—	10/10	—	—	60/60	—	—	78/80	—	—
KFCEH2601C10	10	7,5	1	Ckt Bkr	36.2/40.0	—	—	6/6	—	—	10/10	—	—	60/60	—	—	78/80	—	—
KFCEH9001F15***	15	11,3	1	Fuse	54.2/59.9	36.2/40.0	18.1/20.0	4/4	6/6	10/10	8/8	10/10	10/10	80/90	60/60	25/25	88/89	78/80	75/76
KFCEH9101C15***	15	11,3	1	Ckt Bkr	—	36.2/40.0	18.1/20.0	—	6/6	10/10	—	10/10	10/10	—	60/60	25/25	—	78/80	75/76
KFCEH1601315	15	11,3	3	None	31.3/34.6	—	—	8/6	—	—	10/10	—	—	50/60	—	—	56/90	—	—
KFCEH2001318	18	13,5	3	None	37.6/41.5	—	—	6/6	—	—	10/8	—	—	60/70	—	—	76/77	—	—
KFCEH9201F20***	20	15,0	1	Fuse	72.3/79.9	36.2/40.0	36.2/40.0	3/2	6/6	8/8	8/6	10/10	10/10	100/110	60/60	50/50	85/109	78/80	59/59
KFCEH9301C20***	20	15,0	1	Ckt Bkr	—	36.2/40.0	36.2/40.0	—	6/6	8/8	—	10/10	10/10	—	60/60	50/50	—	78/80	59/59
—	24	18,0	3	Fuse	50.1/55.4	—	—	4/4	—	—	8/8	—	—	80/80	—	—	94/95	—	—
KFCEH3401F24H***	24	18,0	1	Fuse	86.7/95.5	—	—	1/1	—	—	6/6	—	—	125/150	—	—	115/116	—	—
—	30	22,5	3	Fuse	62.6/69.2	—	—	3/3	—	—	8/8	—	—	90/100	—	—	97/98	—	—
KFCEH3501F30H***	30	22,5	1	Fuse	109.0/120.0	—	—	0/00	—	—	6/6	—	—	150/175	—	—	117/150	—	—

SMART HEAT ELECTRICAL DATA

HEATER PART NO.	KW	PHASE	INTERNAL CIRCUIT PROTECTION	HEATER AMPS 208/230V			BRANCH CIRCUIT						Max Fuse/Ckt Brk Amps 208/230V			Max Wire Length 208/230V (FT)†			
				Single Circuit	Dual Circuit		Min Wire Size (AWG) 208/230V††		Min Gnd Wire Size 208/230V		Single Circuit	Dual Circuit		Single Circuit	Dual Circuit		Single Circuit	Dual Circuit	
					L1,L2	L3,L4	L1,L2	L3,L4	L1,L2	L3,L4		L1,L2	L3,L4		L1,L2	L3,L4		L1,L2	L3,L4
KFCEH0101H10	10	7,5	1	None	32.5/35.9	—	—	44.0/48.3	—	—	10/10	—	—	45/50	—	—	60/61	—	—
KFCEH0201H15	15	11,3	1	Fuse	54.2/59.9	39.7/43.9	14.4/16.0	73.2/80.3	49.7/54.9	23.4/25.4	4/4	8/6	10/10	8/8	10/10	10/10	80/90	50/60	25/30
KFCEH0301H20	20	15,0	1	Fuse	72.3/79.9	36.2/40.0	36.2/40.0	97.2/106.7	52.0/56.8	45.3/50.0	3/2	6/6	8/8	8/8	10/10	10/10	100/110	60/60	50/50

FIELD MULTIPOINT WIRING OF 24-AND 30-KW SINGLE PHASE

HEATER PART NO.	KW	PHASE	HEATER AMPS 208/230V			MIN AMPACITY 208/230V**						MIN WIRE SIZE (AWG) 208/230V††			MAX FUSE/CKT BKR AMPS 208/230V			MAX WIRE LENGTH 208/230V (FT)††		
			L1,L2	L3,L4	L5,L6	L1,L2	L3,L4	L5,L6	L1,L2	L3,L4	L5,L6	L1,L2	L3,L4	L5,L6	L1,L2	L3,L4	L5,L6	L1,L2	L3,L4	L5,L6
KFCEH0401F24†	24	18,0	1	28.9/32.0	28.9/32.0	44.7/48.5	36.2/40.0	36.2/40.0	8/8	8/8	8/8	10/10	45/50	40/40	40/40	59/60	73/74	73/74		
KFCEH0501F30†	30	22,5	1	36.2/40.0	36.2/40.0	53.8/58.5	45.3/50.0	45.3/50.0	6/6	8/8	8/8	10/10	60/60	50/50	50/50	78/80	59/59	59/59		

- † Field convertible to 1 phase, single or multiple supply circuit.
- ‡ Field convertible to 3 phase.
- ** Includes blower motor amps of largest fan coil used with heater.
- †† Copper wire must be used. If other than uncoated (non-plated), 75°C ambient, copper wire (solid wire for 10 AWG and smaller, stranded wire for larger than 10 AWG) is used, consult applicable tables of the National Electric Code (ANSI/NFPA 70).
- ‡ Length shown is as measured 1 way along wire path between unit and service panel for a voltage drop not to exceed 2%.
- *** Heaters are Intelligent Heat capable when used with the FK, FV fan coils and corporate 2-speed programmable thermostat (TSTATBPP2S01-A), or Thermostat™ Control (TSTATBPPRH01-B).
- NOTES: 1. For fan coil sizes 018-036.
- 2. For fan coil sizes 042-060 and all FK4D, FV4B sizes.
- 3. Single circuit application of F15 and F20 heaters requires single-point wiring kit accessory

ELECTRIC HEATER STATIC PRESSURE DROP

The airflow performance data was developed using fan coils with 10-kw electric heaters (2 elements) in the 001 and 002 size units and 15-kw heaters (3 elements) in the 003 and 004 size units.

001, 002

HEATER ELEMENTS	KW	EXTERNAL STATIC PRESSURE CORRECTION
0	0	+0.02
1	3, 5	+0.01
2	8, 10	0
3	9, 15	-0.02
4	20	-0.04

003, 004

HEATER ELEMENTS	KW	EXTERNAL STATIC PRESSURE CORRECTION
0	0	+0.04
2	8, 10	+0.02
3	9, 15	0
4	20	-0.02
6	18, 24, 30	-0.10

The airflow performance data was developed using fan coils with 10-kw electric heaters (2 elements) in the 001 and 002 units and 15-kw heaters (3 elements) in the 003 and 004 units. For fan coils with heaters of a different number of elements, the available external static at a given CFM from the curve may be corrected by adding or subtracting available external static pressure as indicated above.

ACCESSORIES

ITEM	ACCESSORY PART NO.*	FAN COIL SIZE USED WITH
Disconnect Kit	KFADK0101DSC	Cooling Controls and Heaters 3-kw through 10-kw
Downflow Base Kit	KFACB0101CFB	001
	KFACB0201CFB	002
	KFACB0301CFB	003, 004
Downflow Conversion Kit	KFADC0201SLP	Slope Coil Units — 001, 002
	KFADC0401ACL	A-Coil Units — 003, 004
Single-Point Wiring Kit	KFASP0101SPK	Only with 15- and 20-kw Fused Heaters
Filter Kit (12 pack)	KFAFK0112SML	001
	KFAFK0212MED	002
	KFAFK0312LRG	003, 004
Evaporator Coil	KFAEC0501024	001
	KFAEC0601036	002
	KFAEC0301048	003
	KFAEC0401060	004
Downflow/Horizontal Conversion Gasket Kit	KFAHD0101SLP	All

* Factory authorized and listed, field-installed.

Accessory Kits Description Suggested and Required Use

1. Disconnect Kit

The kit is used to disconnect electrical power to the fan coil so service or maintenance may be performed safely.

SUGGESTED USE: FH4 units for 3-kw through 10-kw electric resistance heaters and cooling controls.

2. Downflow Base Kit

This kit is designed to provide a 1-in. minimum clearance between unit discharge plenum, ductwork, and combustible materials. It also provides a gap free seal with the floor.

REQUIRED USE: This kit must be used whenever FH4 fan coils are used in downflow applications.

3. Downflow Conversion Kit

Fan coils are shipped from the factory for upflow or horizontal-left applications. Downflow conversion kits provide proper condensate water drainage and support for the coil when used in downflow applications. Separate kits are available for slope coils and A-coils.

REQUIRED USE: This kit must be used whenever FH4A fan coils are used in downflow applications.

4. Single Point Wiring Kit

The single point wiring kit acts as a jumper between L1 and L3 lugs, and between the L2 and L4 lugs. This allows the installer to run 2 heavy-gage, high-voltage wires into the fan coil rather than 4 light-gage, high-voltage wires.

SUGGESTED USE: FH4 fan coils with 15-kw and 20-kw fused heaters only.

5. Fan Coil Filter

The kit consists of 12 fan coil framed filters. These filters collect large dust particles from the return air entering the fan coil and prevent them from collecting on the coil. This process helps to keep the coil clean, which increases heat transfer and in turn the efficiency of the system.

SUGGESTED USE: To replace filters in FH4 fan coils.

6. Evaporator Coil Kit

The kit contains a heating/cooling coil and drain pan.

SUGGESTED USE: Accessory coil used with FH4 fan unit.

7. Downflow/Horizontal Conversion Gasket Kit

This kit provides the proper gasketing of units when applied in either a Downflow or Horizontal application.

REQUIRED USE: FH4 fan coils.

MATCHED SYSTEM

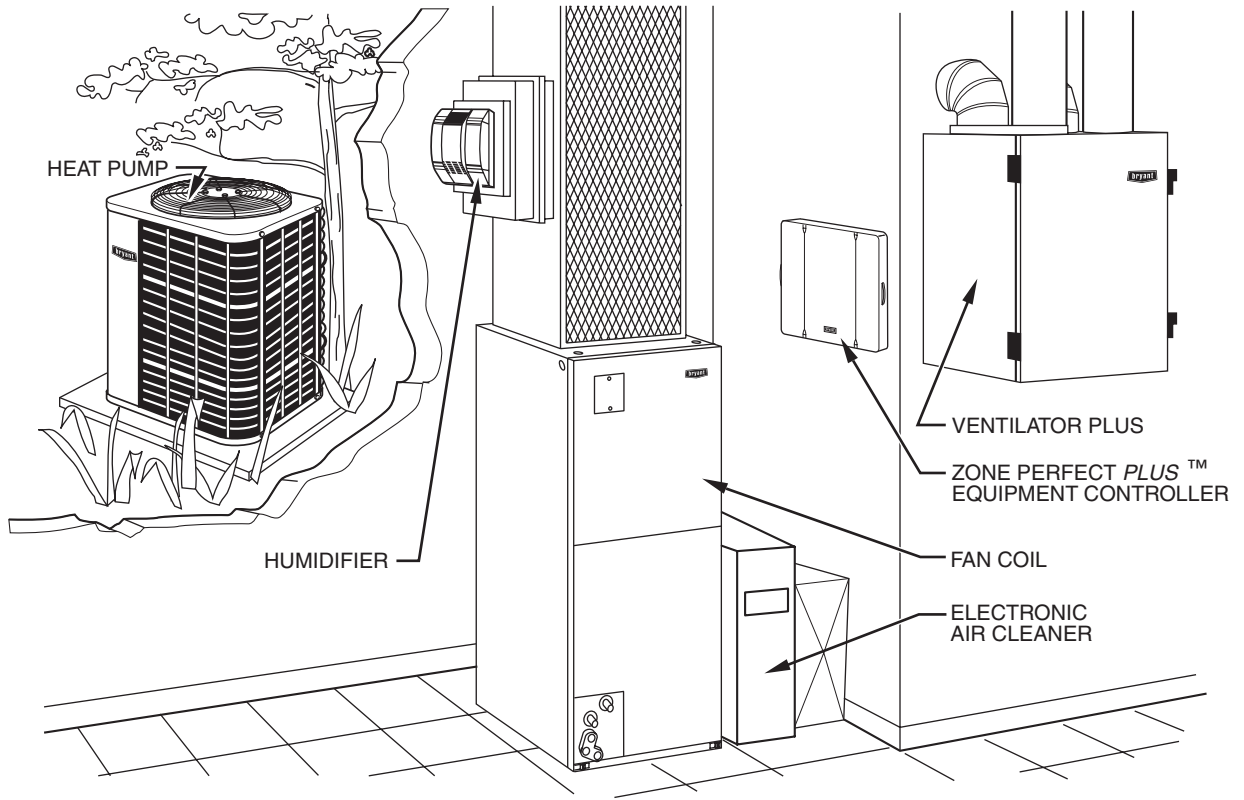

A02295

SERVICE TRAINING

Packaged Service Training programs are an excellent way to increase your knowledge of the equipment discussed in this manual, including:

- Unit Familiarization
- Maintenance
- Installation Overview
- Operating Sequence

A large selection of product, theory, and skills programs is available, using popular video-based formats and materials. All include video and/or slides, plus companion book.

Classroom Service Training plus "hands-on" the products in our labs can mean increased confidence that really pays dividends in faster troubleshooting, fewer callbacks. Course descriptions and schedules are in our catalog.

CALL FOR FREE CATALOG 1-800-644-5544

Packaged Service Training Classroom Service Training

A94328

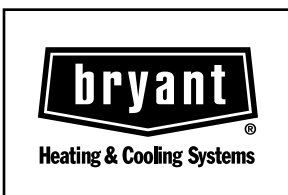

SPECIFICATIONS SUBJECT TO CHANGE WITHOUT NOTICE

UNIT MUST BE INSTALLED IN ACCORDANCE
WITH INSTALLATION INSTRUCTIONS

Cancels: PDS FH4B.01.2
Form PDS FH4B.01.3