

To all our customers

Regarding the change of names mentioned in the document, such as Hitachi Electric and Hitachi XX, to Renesas Technology Corp.

The semiconductor operations of Mitsubishi Electric and Hitachi were transferred to Renesas Technology Corporation on April 1st 2003. These operations include microcomputer, logic, analog and discrete devices, and memory chips other than DRAMs (flash memory, SRAMs etc.) Accordingly, although Hitachi, Hitachi, Ltd., Hitachi Semiconductors, and other Hitachi brand names are mentioned in the document, these names have in fact all been changed to Renesas Technology Corp. Thank you for your understanding. Except for our corporate trademark, logo and corporate statement, no changes whatsoever have been made to the contents of the document, and these changes do not constitute any alteration to the contents of the document itself.

Renesas Technology Home Page: <http://www.renesas.com>

Renesas Technology Corp.
Customer Support Dept.
April 1, 2003

SH7055 Evaluation Chip Board (HS7055EBK81H) for the E8000 Emulator

User's Manual

HITACHI



HS7055EBK81HE(A)

Notice

When using this document, keep the following in mind:

1. This document may, wholly or partially, be subject to change without notice.
2. All rights are reserved: No one is permitted to reproduce or duplicate, in any form, the whole or part of this document without Hitachi's permission.
3. Hitachi will not be held responsible for any damage to the user that may result from accidents or any other reasons during operation of the user's unit according to this document.
4. Circuitry and other examples described herein are meant merely to indicate the characteristics and performance of Hitachi's semiconductor products. Hitachi assumes no responsibility for any intellectual property claims or other problems that may result from applications based on the examples described herein.
5. No license is granted by implication or otherwise under any patents or other rights of any third party or Hitachi, Ltd.
6. **MEDICAL APPLICATIONS:** Hitachi's products are not authorized for use in **MEDICAL APPLICATIONS** without the written consent of the appropriate officer of Hitachi's sales company. Such use includes, but is not limited to, use in life support systems. Buyers of Hitachi's products are requested to notify the relevant Hitachi sales office when planning to use the products in **MEDICAL APPLICATIONS**.

Preface

This manual describes how to connect and operate the EV-chip board. The EV-chip board incorporates an evaluation chip for connection to a user system that uses the SH7055 with the E8000 emulator.

Read and understand Sec. 3, "Preparation before Use" of the E8000 Emulator User's Manual before using this EV-chip board.

CAUTION

The EV-chip board is only for connection to a user system that uses the SH7055 with the E8000 emulator. It cannot be used for user systems that target other devices.

Contents

Section 1	Components	1
1.1	EV-Chip Board Components	1
1.2	Component Names	2
Section 2	Preparation before Use	4
2.1	Preparing the User System	4
2.1.1	Recommended Mounting Pad Dimensions of the User System	7
2.1.2	Connector Position on the User System	9
Section 3	Connecting the EV-Chip Board to the User System.....	11
3.1	Connecting the EV-Chip Board to the User System.....	11
3.1.1	Connecting the Specified Connector	11
3.1.2	Connecting the Trace Cables to the EV-Chip Board.....	12
3.1.3	Connecting the EV-Chip Board to the User System Board.....	15
Figures		
Figure 1.1	EV-Chip Board.....	2
Figure 2.1	Recommended Mounting Pad Dimensions.....	8
Figure 2.2	Connector Position on the User System (Top View).....	10
Figure 2.3	Component Height Restriction	10
Figure 3.1	Connecting Trace Cables to the EV-Chip Board.....	14
Figure 3.2	Connecting the EV-Chip Board to the User System.....	16
Tables		
Table 1.1	EV-chip Board Components.....	1
Table 2.1	Pin Assignment of the HS7055EBK81H User Interface (UCN1)	5
Table 2.1	Pin Assignment of the HS7055EBK81H User Interface (UCN2)	7
Table 2.1	Pin Assignment of the HS7055EBK81H User Interface (UCN3)	6

Section 1 Components

1.1 EV-Chip Board Components

Table 1.1 lists the product components of the EV-chip board (HS7055EBK81H: 3 x 100-pin connector type). Check all the components after unpacking.

Table 1.1 EV-chip Board Components

Item	Quantity	Remarks
EV-chip board (HS7055EBK81H)	1	Consists of two boards. <ul style="list-style-type: none">• HS7055PWB20H (for connecting to the E8000 station)• HS7055PWB30H (3 x 100-pin connector)
Documentation	1	User's manual for HS7055EBK81H (this manual)

Note: Use the specific connector (FX2-100P-1.27SVL manufactured by HIROSE ELECTRIC CO., LTD.) on the user system that is connected to the HS7055EBK81H.

1.2 Component Names

The component names of the EV-chip board are described below.

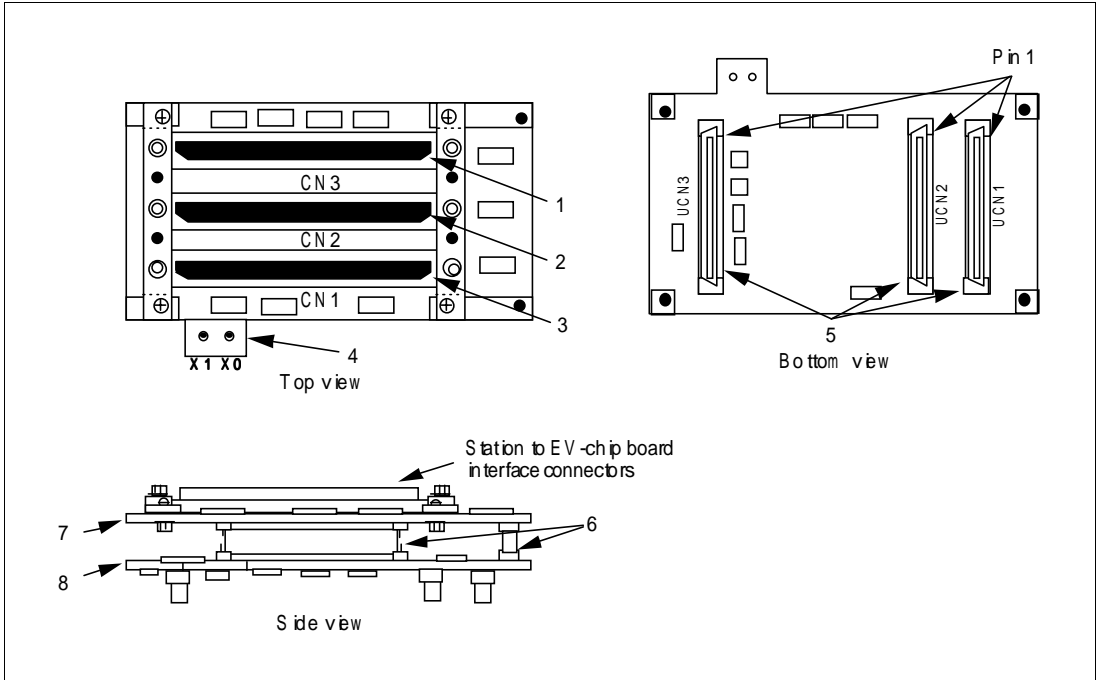

Figure 1.1 EV-Chip Board

- | | |
|--|--|
| 1. Station to EV-chip board interface connector CN3: | For trace cable 3 which connects the E8000 station to the EV-chip board. |
| 2. Station to EV-chip board interface connector CN2: | For trace cable 2 which connects the E8000 station to the EV-chip board. |
| 3. Station to EV-chip board interface connector CN1: | For trace cable 1 which connects the E8000 station to the EV-chip board. |
| 4. Crystal oscillator terminals: | For installing a crystal oscillator to be used as a clock source for the SH7055. |
| 5. User-system connector: | For connecting the user system. |
| 6. Board connector: | For connecting HS7055PWB20H and HS7055PWB30H. |
| 7. HS7055PWB20H: | Includes connectors for interfacing with the E8000 station via trace cables. |

8. HS7055PWB30H:

Includes connectors for interfacing with the user system.

Section 2 Preparation before Use

2.1 Preparing the User System

Table 2.1 lists the user interface pin assignment of the specific connector (FX2-100P-1.27SVL manufactured by HIROSE ELECTRIC CO., LTD.) when the target MCU is the SH7055.

Table 2.1 Pin Assignment of the HS7055EBK81H User Interface (UCN1)

Pin No.	Pin Name	Pin No.	Pin Name	Pin No.	Pin Name
1	GND	35	PJ6/TIO2G	69	PK15/TO8P
2	GND	36	PJ7/TIO2H	70	GND
3	GND	37	GND	71	GND
4	GND	38	PJ8/TIO5C	72	GND
5	AN16	39	PJ9/TIO5D	73	GND
6	AN17	40	PJ10/TI9A	74	PL0/TI10
7	AN18	41	PJ11/TI9B	75	PL1/TIO11A/IRQ6
8	AN19	42	GND	76	PL2/TIO11B/IRQ7
9	GND	43	PJ12/TI9C	77	PL3/TCLKB
10	AN20	44	PJ13/TI9D	78	GND
11	AN21	45	PJ14/TI9E	79	PL4/ADTRG0
12	AN22	46	PJ15/TI9F	80	PL5/ADTRG1
13	AN23	47	GND	81	PL6/ADEND
14	GND	48	GND	82	PL7/SCK2
15	AN24	49	GND	83	GND
16	AN25	50	GND	84	PL8/SCK3
17	AN26	51	PK0/TO8A	85	PL9/SCK4/IRQ5
18	AN27	52	PK1/TO8B	86	PL10/HTxD
19	GND	53	PK2/TO8C	87	PL11/HRxD
20	AN28	54	PK3/TO8D	88	GND
21	AN29	55	GND	89	PL12/IRQ4
22	AN30	56	PK4/TO8E	90	PL13/IRQOUT
23	AN31	57	PK5/TO8F	91	GND
24	GND	58	PK6/TO8G	92	GND
25	GND	59	PK7/TO8H	93	GND
26	GND	60	GND	94	GND
27	GND	61	PK8/TO8I	95	Not connected
28	PJ0/TIO2A	62	PK9/TO8J	96	Not connected
29	PJ1/TIO2B	63	PK10/TO8K	97	Not connected
30	PJ2/TIO2C	64	PK11/TO8L	98	Not connected
31	PJ3/TIO2D	65	GND	99	Not connected
32	GND	66	PK12/TO8M	100	Not connected
33	PJ4/TIO2E	67	PK13/TO8N		
34	PJ5/TIO2F	68	PK14/TO8O		

Table 2.1 Pin Assignment of the HS7055EBK81H User Interface (UCN2)

Pin No.	Pin Name	Pin No.	Pin Name	Pin No.	Pin Name
1	AVCC	35	PA5/TIO3B	69	PC0/TxD1
2	GND	36	PA6/TIO3C	70	PC1/RxD1
3	AVREF	37	PA7/TIO3D	71	PC2/TxD2
4	AVREF	38	GND	72	PC3/RxD2
5	GND	39	PA8/TIO4A	73	PC4/IRQ4
6	GND	40	PA9/TIO4B	74	GND
7	AN0	41	PA10/TIO4C	75	PG0/PULS7/HRxD
8	AN1	42	PA11/TIO4D	76	PG1/IRQ1
9	AN2	43	GND	77	PG2/IRQ2/ADEND
10	AN3	44	PA12/TIO5A	78	PG3/IRQ3/ADTRG0
11	GND	45	PA13/TIO5B	79	GND
12	AN4	46	PA14/TxD0	80	TMS
13	AN5	47	PA15/RxD0	81	/TRST
14	AN6	48	GND	82	TDI
15	AN7	49	PB0/TO6A	83	TDO
16	GND	50	PB1/TO6B	84	TCK
17	AN8	51	PB2/TO6C	85	GND
18	AN9	52	PB3/TO6D	86	/AUDRST
19	AN10	53	GND	87	AUDMD
20	AN11	54	PB4/TO7A/TO8A	88	GND
21	GND	55	PB5/TO7B/TO8B	89	AUDD0
22	AN12	56	PB6/TO7C/TO8C	90	AUDD1
23	AN13	57	PB7/TO7D/TO8D	91	GND
24	AN14	58	GND	92	AUDD2
25	AN15	59	PB8/TxD3/TO8E	93	AUDD3
26	GND	60	PB9/RxD3/TO8F	94	GND
27	/WDTOVF	61	PB10/TxD4/HTxD/TO8G	95	AUDCK
28	GND	62	PB11/RxD4/HRxD/TO8H	96	/AUDSYNC
29	PA0/TIOA	63	GND	97	GND
30	PA1/TIOB	64	PB12/TCLKA	98	PVCC2
31	PA2/TIOC	65	PB13/SCK0	99	GND
32	PA3/TIOD	66	PB14/SCK1/TCLKB	100	FWE
33	GND	67	PB15/PULS5/SCK2		
34	PA4/TIO3A	68	GND		

Table 2.1 Pin Assignment of the HS7055EBK81H User Interface (UCN3)

Pin No.	Pin Name	Pin No.	Pin Name	Pin No.	Pin Name
1	NMI	35	MD1	69	GND
2	GND	36	MD2	70	PE7/A7
3	PVCC1	37	GND	71	PE6/A6
4	GND	38	EXTAL	72	PE5/A5
5	PH15/D15	39	GND	73	PE4/A4
6	PH14/D14	40	PF15/BREQ	74	GND
7	GND	41	PF14/BACK	75	PE3/A3
8	PH13/D13	42	PF13/CS3	76	PE2/A2
9	PH12/D12	43	PF12/CS2	77	PE1/A1
10	GND	44	GND	78	PE0/A0
11	PH11/D11	45	PF11/CS1	79	GND
12	PH10/D10	46	PF10/CS0	80	PD0/TIO1A
13	GND	47	PF9/RD	81	PD1/TIO1B
14	PH9/D9	48	PF8/WAIT	82	PD2/TIO1C
15	PH8/D8	49	GND	83	PD3/TIO1D
16	GND	50	PF7/WRH	84	GND
17	PH7/D7	51	PF6/WRL	85	PD4/TIO1E
18	PH6/D6	52	PF5/A21/POD	86	PD5/TIO1F
19	GND	53	PF4/A20	87	PD6/TIO1G
20	PH5/D5	54	GND	88	PD7/TIO1H
21	PH4/D4	55	PF3/A19	89	GND
22	GND	56	PF2/A18	90	PD8/PULS0
23	PH3/D3	57	PF1/A17	91	PD9/PULS1
24	PH2/D2	58	PF0/A16	92	PD10/PULS2
25	GND	59	GND	93	PD11/PULS3
26	PH1/D1	60	PE15/A15	94	GND
27	PH0/D0	61	PE14/A14	95	PD12/PULS4
28	GND	62	PE13/A13	96	PD13/PULS6/HTxD
29	CLK	63	PE12/A12	97	GND
30	GND	64	GND	98	GND(/UVCCSEL)
31	/RES	65	PE11/A11	99	GND
32	/STBY	66	PE10/A10	100	UVCC(3.3V)
33	GND	67	PE9/A9		
34	MD0	68	PE8/A8		

2.1.1 Recommended Mounting Pad Dimensions of the User System

Figure 2.1 shows the dimensions of the recommended mounting pad (footprint) and positioning holes for the specific connector (FX2-100P-1.27SVL) manufactured by HIROSE ELECTRIC CO., LTD. The dimension tolerance is ± 0.1 mm unless otherwise specified.

2.1.2 Connector Position on the User System

CAUTION

Before connecting the connectors (FX2-100P-1.27SVL) to the user system, check the location of pin 1 and the connector shapes as shown in figures 2.2. If the connector direction is incorrect, the EV-chip board cannot be connected to the user system.

Figure 2.2 shows the direction of the connectors (FX2-100P-1.27SVL) on the user system. Comply with the user system component height restriction shown in Figure 2.3 within the external frame of the EV-chip board shown in Figure 2.2.

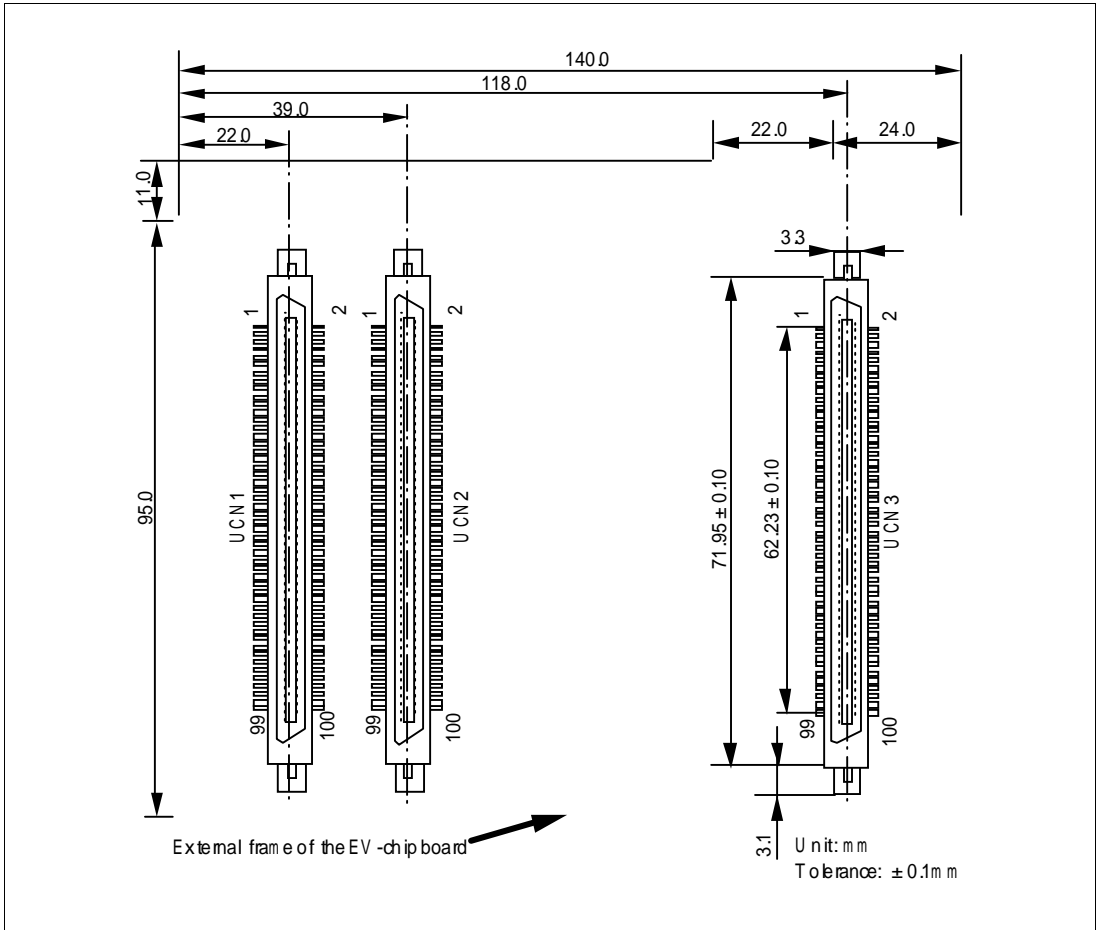

Figure 2.2 Connector Position on the User System (Top View)

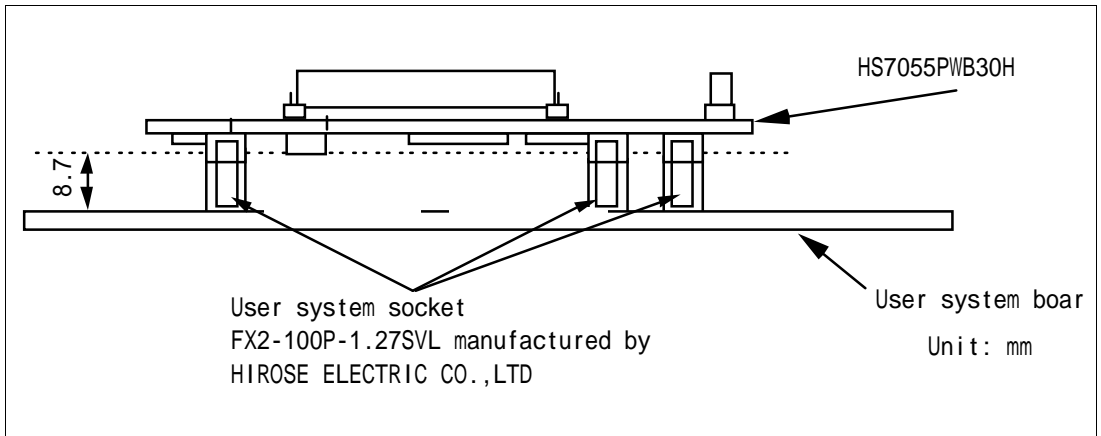

Figure 2.3 Component Height Restriction

Section 3 Connecting the EV-Chip Board to the User System

3.1 Connecting the EV-Chip Board to the User System

3.1.1 Connecting the Specified Connector

This EV-chip board is designed exclusively for the specific connector (type number: FX2-100P-1.27SVL) manufactured by HIROSE ELECTRIC CO., LTD. Therefore, it cannot be used with other connectors.

- Positioning the IC socket

The connector FX2-100P-1.27SVL has two positioning pins. Insert the positioning pins of the connector into the positioning holes of the user system board. Apply an epoxy adhesive to the tips of the positioning pins of the connector to bond the connector to the user system board.

CAUTION

Before connecting the connectors to the user system, check the location of pin 1 on both sides and the connector shapes (UCN1 , UCN2 and UCN3).

- Mounting the connectors

Solder the FX2-100P-1.27SVL onto the user system. Use more solder than usual so that a fillet is formed on the lead edge being soldered.

3.1.2 Connecting the Trace Cables to the EV-Chip Board



WARNING

Always switch OFF the emulator and user system before connecting or disconnecting any CABLES or sockets. Failure to do so will result in a FIRE HAZARD and will damage the user system and the emulator or will result in PERSONAL INJURY. The USER PROGRAM will be LOST.

- EV-chip board condition at shipment
The EV-chip board is shipped with the HS7055PWB20H and HS7055PWB30H connected to each other. When connecting the EV-chip board to the user system, do not separate the HS7055PWB20H from the HS7055PWB30H.

CAUTION

Before connecting the EV-chip board to the user system, confirm that the HS7055PWB20H and HS7055PWB30H are firmly connected by lightly pushing the board.

- Connecting the trace cables to the E8000 station
Before connecting the trace cables to the HS7055PWB20H, connect the trace cables to the E8000 station.

Note: At shipment, trace cables CN2 and CN3 to be connected to the E8000 station are bound into a bundle, and trace cables CN1, CN2, and CN3 to be connected to the EV-chip board are bound into a bundle to prevent an insertion error. For more information on connecting the EV-Chip board to the E8000 station, refer to section 3.2.2, Connecting the EV-Chip Board, in the SH7055 E8000 Emulator User's Manual.

- Connecting the trace cables to the EV-chip board

Align the trace cables with the station to EV-chip board interface connectors CN1, CN2, and CN3 on the EV-chip board. Confirm that each trace cable connected to a connector on the E8000 station is also connected to its corresponding station to EV-chip board interface connector on the EV-chip board. For the prevention of insertion errors, colors are specified on the trace cable connectors and the corresponding EV-chip board interface connectors (CN1: red, CN2: yellow, CN3: blue).

CAUTION

For the prevention of insertion errors, colors are specified on the trace cable connectors and the corresponding EV-chip board interface connectors.

Example

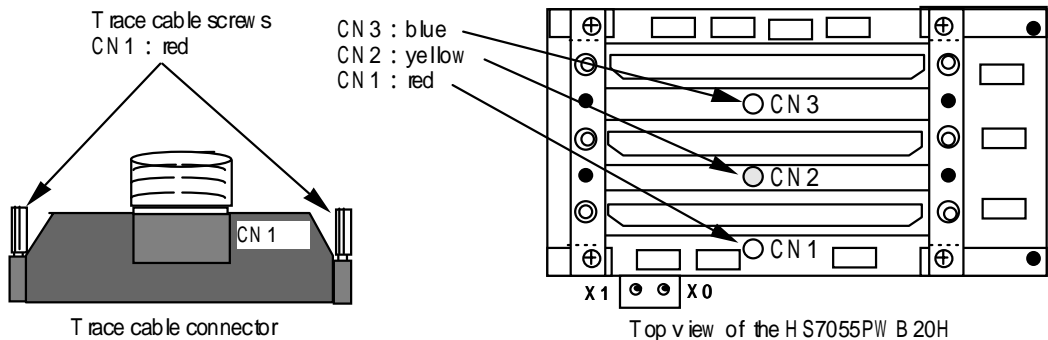

Tighten the screws to connect the trace cable connectors to the station to EV-chip board interface connectors while holding the HS7055PWB30H securely.

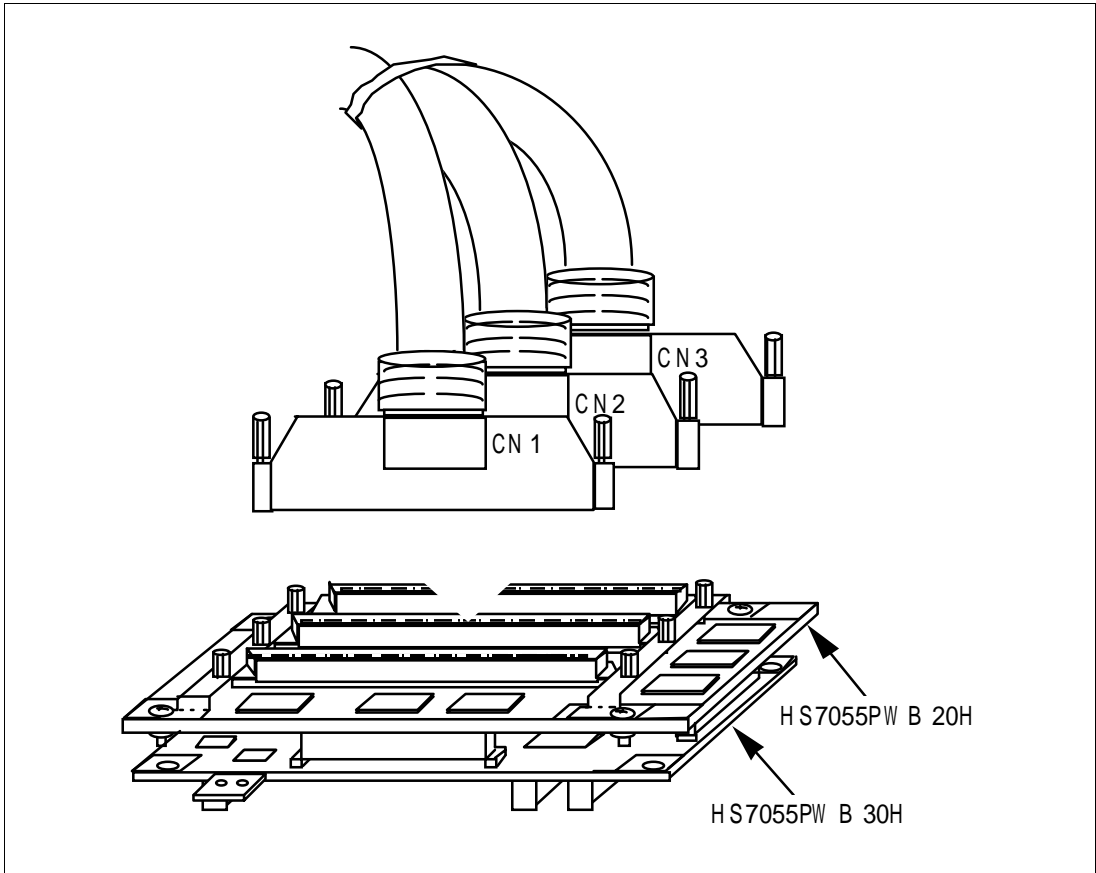

Figure 3.1 Connecting Trace Cables to the EV-Chip Board



WARNING

Make sure the connector shapes and numbers are correctly matched when connecting the trace cables to the station to EV-chip board interface connectors. Failure to do so will result in a FIRE HAZARD.

3.1.3 Connecting the EV-Chip Board to the User System Board

- Connecting the EV-chip board to the user system board

Check the location of the FX2-100P-1.27SVL on the user system. Align the connectors on the HS7055PWB30H of the EV-chip board with those on the user system board, and insert the connectors.

CAUTION

Forcefully connecting the EV-chip board will apply stress to the soldered connectors on the user system, causing cracks in the solder. Gradually push the EV-chip board repeatedly so that no cracks occur in the soldered section of the connectors.

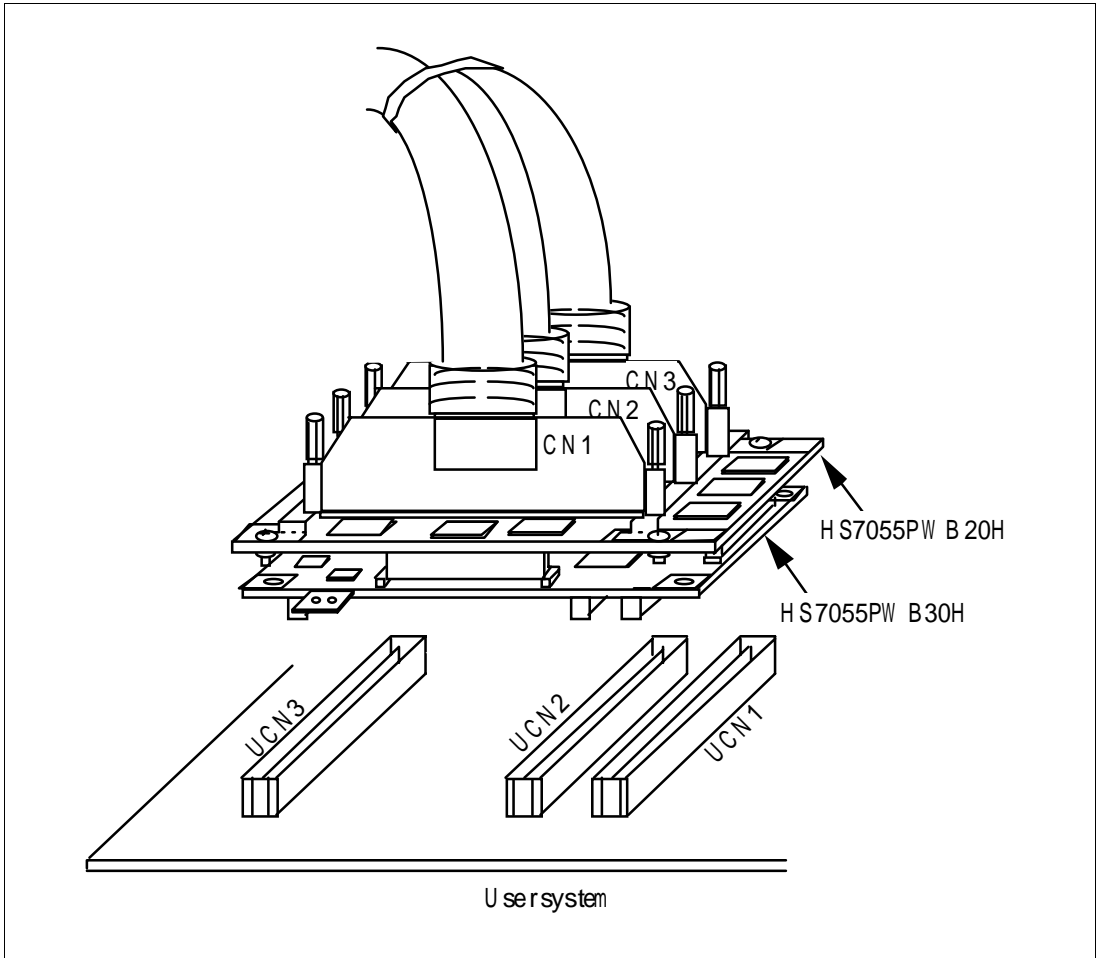

Figure 3.2 Connecting the EV-Chip Board to the User System