

Please read through this User's Manual before use for correct handling.  
Please keep this User's Manual for future reference.

## 1. CAUTIONARY NOTES FOR SAFE USE OF THE PRODUCT

This User's Manual should be carefully read before installing and operating the product. The following symbol is used on the product and in this manual to ensure safe use.



**This symbol is displayed on the product when it is necessary to refer to the User's Manual for information on personnel and instrument safety. This symbol is displayed in the User's Manual to indicate precautions for avoiding danger to the operator, such as an electric shock.**

The following symbols are used only in this manual.



### IMPORTANT

**Indicates that operating the hardware or software in a particular manner may cause damage or result in a system failure.**



### NOTE

**Draws attention to essential information for understanding the operations and/or functions of the product.**

## 2. CHECKING PRODUCT SPECIFICATIONS AND PACKAGED ITEMS

### (1) Checking the Model and Product Specifications

Check that the model and specifications indicated on the nameplate attached to the front face of the main unit are as ordered.

### (2) Packaged Items

Check that the packing carton contains the following items:

- JM12: 1
- Spacer (used for DIN rail mounting): 1
- Range labels: 2
- User's Manual (this manual: IM 77J03M01-02E): 1 copy

## 3. GENERAL

The JM11 is a plug-in type isolator that converts mV DC voltage signals into isolated DC current or DC voltage signals.

## 4. MOUNTING METHOD



### NOTE

**Insert/pull out the main unit into/from the socket vertically to the face of socket. Otherwise the terminals are bent and it may cause a bad contact.**

### 4.1 Wall Mounting

Remove the stoppers (top and bottom) from the product and pull out the main unit from the socket. Fix the socket on the wall using two M4 screws. Next, insert the main unit into the socket and fasten the main unit with the stoppers (top and bottom).

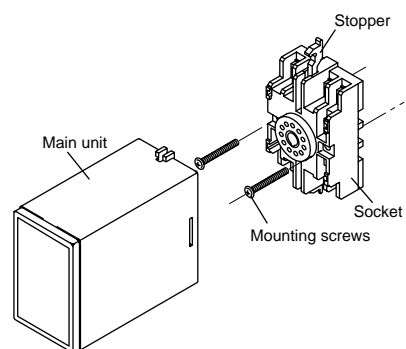

[Mounting Dimensions]

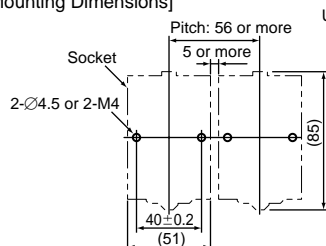

Unit: mm

Note:

- (1) More than 5 mm interval is required for side-by-side close mounting.
- (2) Use the supplied spacer for DIN rail mounting to keep 5 mm interval.

### 4.2 DIN Rail Mounting

Insert a DIN rail into the upper part of the DIN rail groove on the rear of the socket, and then slide the slide lock at the lower part of the socket upwards until the socket is fixed into position as shown below.

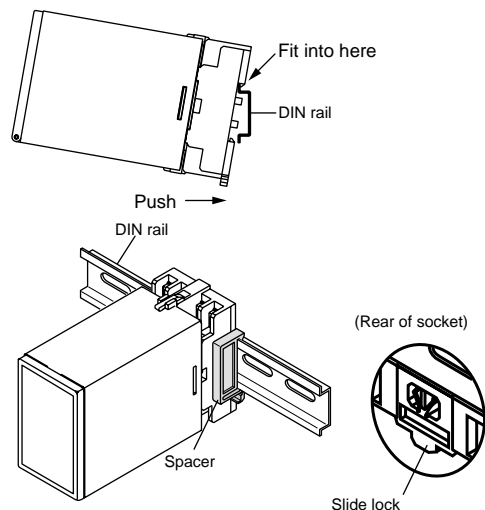

### 4.3 Using a Duct

When using a wiring duct, install the duct at least 20 mm away from the top and bottom faces of the main unit.

## 5. INSTALLATION LOCATIONS

- Avoid the following environments for installation locations: Areas with vibration, corrosive gases, dust, water, oil, solvents, direct sunlight, radiation, a strong electric field, and/or a strong magnetic field
- If there is any risk of a surge being induced into the power line and/or signal lines due to lightning or other factors, a dedicated lightning arrester should be used as protection for both this unit and a field-installed device.

## 6. EXTERNAL WIRING



### WARNING

**To avoid the risk of an electric shock, turn off the power supply and use a tester or similar device to ensure that no power is supplied to a cable to be connected, before carrying out wiring work.**

Wiring should be connected to the terminals on the socket of the product. The terminals for external connections are of M3.5 screws. Use crimp-on terminal lugs for connections to the terminals.

- Recommended cables: A nominal cross-sectional area of 0.5 mm<sup>2</sup> or thicker for signal cables, and that of 1.25 mm<sup>2</sup> or thicker for power cables.

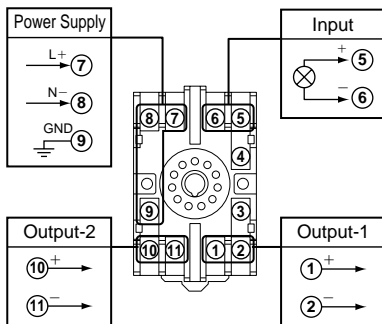

### IMPORTANT

- The power line and input/output signal lines should be installed away from noise-generating sources. Other wise accuracy cannot be guaranteed.
- The grounding resistance must be 100 Ω (JIS Class D grounding). The length and thickness of the grounding cable should be as short and thick as possible. Directly connect the lead from the ground terminal (terminal no. 9) of the product to the ground. Do not carry out daisy-chained inter-ground terminal wiring.
- Use of the product ignoring the specifications may cause overheating or damage. Before turning on the power, ensure the following:
  - (a) Power supply voltage and input signal value applied to the product should meet the required specifications.
  - (b) The external wiring to the terminals and wiring to ground are as specifications.
- Do not operate the product in the presence of flammable or explosive gases or vapors. To do so is highly dangerous.
- The product is sensitive to static electricity; exercise care in operating it. Before you operate the product, touch a nearby metal part to discharge static electricity.

## 7. PART NAMES OF FRONT PANEL

The figure below shows the JM12 with its front panel (cover) being open.

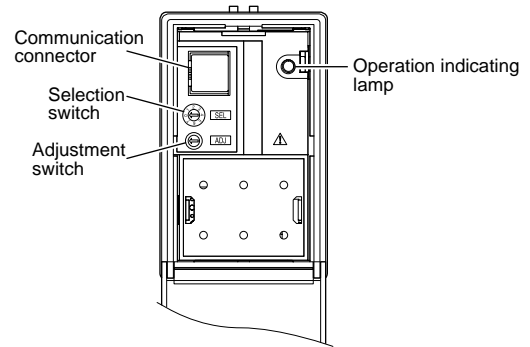

### 7.1 Operation Indicating Lamp

The operation indicating lamp shows the operating status, abnormal setting, and adjustment operating status using the adjustment switch on the front panel.

- (1) When the lamp is lit:

Power is turned on and the distributor is in the normal status provided that the selection switch is turned to the position "0."

- (2) When the lamp is flashing rapidly:

The lamp repeats the rapid flashing until the internal processing is completed during output adjustments and the wiring resistance correction using the adjustment switch.

- (3) When the lamp is flashing slowly:

The lamp repeats the slow flashing until the distributor regains its normal status when the following abnormalities occur.

- Abnormal parameter setting
- The selection switch is turned to the positions other than "0."
- Input is out of the range of -10 to 110%.

### 7.2 Communication Connector

The communication connector is used when setting the parameters through a PC (VJ77 Parameter Setting Tool) or the Handy Terminal.

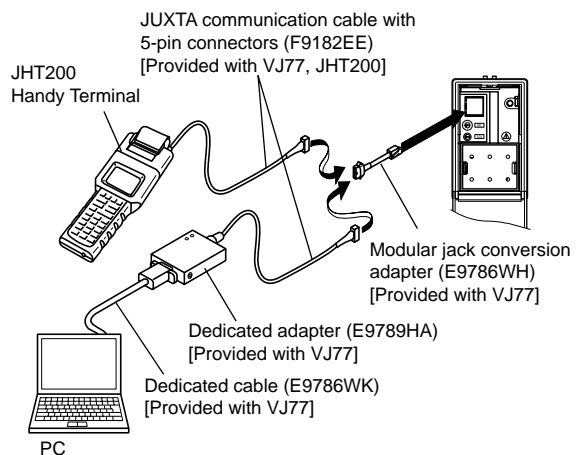

### 7.3 Selection Switch and Adjustment Switch

The following adjustments can be made using the switches on the front panel (selection switch and adjustment switch) without the dedicated setting tool (see Section 7.2, "Communication Connector").

The adjusted value is stored about 1 second after operating the adjustment switch. Also when the rotating direction of the adjustment switch is changed, the adjusted value becomes effective about 1 second after the change.

Position of selection switch	Items to be adjusted	
	0	No function
	1	Zero adjustment of output-1
	2	Span adjustment of output-1
	3	Zero adjustment of output-2
	4	Span adjustment of output-2
5	Wiring resistance correction	
Rotating direction of adjustment switch	Action to be adjusted	
	Clockwise	Increase of output adjusted value and execution of wiring resistance correction
	Counterclockwise	Decrease of output adjusted value and reset of wiring resistance corrected value

### [Adjusted volume by adjustment switch]

One%álick changes about 0.005% of the output range.

#### 7.3.1 Adjusting output using the switches on the front panel

- (1) Zero adjustment of output  
Turn the selection switch to "1." Rotate the adjustment switch clockwise to increase the output, and counterclockwise to decrease the output.
- (2) Span adjustment of output  
Turn the selection switch to "2." Rotate the adjustment switch clockwise to increase the output, and counterclockwise to decrease the output.

**Output 2 can be adjusted by the same operations as above.**

- (3) Zero adjustment of output-2  
Turn the selection switch to "3." An adjustment switch adjusts.
- (4) Span adjustment of output-2  
Turn the selection switch to "4." An adjustment switch adjusts.

#### 7.3.2 Correcting wiring resistance using the switches on the front panel

When an error occurs due to the influence of the input wiring resistance, perform the wiring as the figure below, apply a stable input, and execute the following operations. Then the wiring resistance can be corrected automatically.

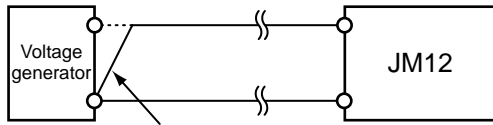

Two signal lines are connected to the same terminal of one side.

Be sure to rotate the adjustment switch counterclockwise to reset the corrected value before executing the wiring resistance correction.

- (1) Executing the wiring resistance correction  
Turn the selection switch to "5", and rotate the adjustment switch clockwise. Then the wiring resistance is adjusted after 1 second automatically.
- (2) Resetting the wiring resistance corrected value  
Turn the selection switch to "5", and rotate the adjustment switch counterclockwise. Then the adjusted value is reset after 1 second.



### NOTE

- **Make sure to turn the selection switch back to the position "0" after each adjustment. The positions other than "0" mean the adjustment modes, and it may cause a wrong operation.**
- **When the selection switch is turned to the positions other than "0", setting through the setting tool is impossible.**

## 8. SETTING PARAMETERS

Set the parameters through a PC (VJ77 Parameter Setting Tool) or the Handy Terminal. For details how to set, see Chapter 10, "List of Parameters", User's manual "VJ77 PC-based Parameter Setting Tool" (IM 77J01J77-01E), or User's manual "JHT200 Handy Terminal" (IM JF81-02E). The description in the [ ] indicates the parameters.



### NOTE

- **Changing the input range and the burnout action direction resets the input adjusted value and the wiring resistance corrected value.**
- **Execute the wiring resistance correction when the burnout action direction or input wiring is changed.**

#### 8.1 Setting Input Range

Set the input range 0% in [D27:INPUT1L\_RNG], and the input range 100% in [D28:INPUT1H\_RNG].  
Setting range: Within -60 to +240 mV DC, 3 mV of span minimum

#### 8.2 Setting Burnout Action

Set the burnout action in [D43:BURN OUT].  
Set "OFF", "UP", or "DOWN."

### 8.3 Correcting Wiring Resistance

Correct the wiring resistance in [P01:WIRING R].

Select "EXECUTE" for correction, and "RESET" for resetting the corrected value.

Perform wiring as the figure shown in Subsection 7.3.2, "Correcting wiring resistance using the switches on the front panel" before correcting wiring resistance.

## 9. MAINTENANCE

The product starts running immediately when the power is turned on; however, it needs 10 to 15 minutes of warm-up before it meets the specified performance.

#### 9.1 Calibration Apparatus

- A DC voltage/current standard (Yokogawa 7651 or the equivalent)
- A digital mutimeter (Yokogawa 7561 or the equivalent)
- A precision resistor of  $250 \Omega \pm 0.01\%$ , 1 W
- A setting tool for adjustment  
(See Section 7.2, "Communication Connector.")

#### 9.2 Calibration Procedure

- (1) Connect the instruments as shown below. First adjust the output-1 signal and then the output-2 signal.
  - (2) Use the DC voltage/current standard and apply input signals equivalent to 0, 25, 50, 75, and 100% of the input span to the isolator.
  - (3) Check to see the corresponding output voltages are 0, 25, 50, 75, and 100% respectively and within the specified accuracy rating. "R" is used for current output.
- If the output signals are out of the accuracy rating range, adjust the output signal level through a setting tool (VJ77 Parameter Setting Tool or JHT200 Handy Terminal), or using the selection switch and adjustment switch on the front panel.  
For adjustment through a setting tool, see each user's manual of setting tool, and Chapter 10, "List of Parameters." For adjustment using the switches on the front panel, see Section 7.3, "Selection Switch and Adjustment Switch."  
VJ77 user's manual: "VJ77 PC-based Parameter Setting Tool" (IM 77J01J77-01E)  
JHT200 user's manual: "JHT200 Handy Terminal" (IM JF81-02E).

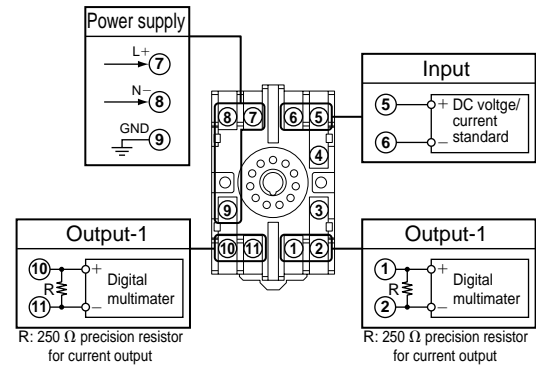

## 10. LIST OF PARAMETERS

Parameter Display		Item
	MODEL	Model
	TAG NO	Tag number
	SELF CHK	Self-check result
<b>A</b>	<b>DISPLAY1</b>	<b>Display1</b>
A01	INPUT1	Input-1
A07	OUTPUT1	Output-1
A08	OUTPUT2	Output-2
A54	STATUS	Status *1
A56	REV NO	REV No.
A58	MENU REV	MENU REV
A60	SELF CHK	Self-check result
<b>B</b>	<b>DISPLAY2</b>	<b>Display2</b>
B01	INPUT1	Input-1
B07	OUTPUT1	Output-1
B08	OUTPUT2	Output-2
B60	SELF CHK	Self-check result
<b>D</b>	<b>SET (I/O)</b>	<b>Setting (I/O) *3</b>
D01	TAG NO.1	Tag number-1
D02	TAG NO.2	Tag number-2
D03	COMMENT1	Comment-1
D04	COMMENT2	Comment-2
D13	LINEARIZE	Linearize *2
D27	INPUT1 L_RNG	Input low range
D28	INPUT1 H_RNG	Input high range
D38	OUT1 L_RNG	Output-1 low range *2
D39	OUT1 H_RNG	Output-1 high range *2
D40	OUT2 L_RNG	Output-2 low range *2
D41	OUT2 H_RNG	Output-2 high range *2
D43	BURN OUT	Burnout
D49	OUT1 DR	Direction of output-1 action
D50	OUT2 DR	Direction of output-2 action
D60	SELF CHK	Self-check result
<b>P</b>	<b>ADJUST</b>	<b>Adjustment *3</b>
P01	WIRING R	Wiring resistance correction
P02	IN1 ZERO ADJ	Zero adjustment of input-1
P03	IN1 SPAN ADJ	Span adjustment of input-1
P26	OUT1ZERO ADJ	Zero adjustment of output-1
P27	OUT1SPAN ADJ	Span adjustment of output-1
P28	OUT2ZERO ADJ	Zero adjustment of output-2
P29	OUT2SPAN ADJ	Span adjustment of output-2
P60	SELF CHK	Self-check result
<b>Q</b>	<b>TEST</b>	<b>Test *3</b>
Q03	OUT1 TEST	Forced output-1
Q04	OUT2 TEST	Forced output-2
Q60	SELF CHK	Self-check result

\*1 The displayed status is to let the service staff know the past records of the product.

\*2 The parameters are the items to be set at the factory.

\*3 Execute the following operations when indicating "D\*\*\*", "P\*\*\*", or "Q\*\*\*" through JHT200 Handy Terminal.  
Press <F1>key, [ ] key, and <ENTER> key, in this order.  
Enter D, P, or Q in [ ].