



EurotestCOMBO
MI 3125 BT
Instruction manual
Version 2.2 Code no 20 751 577

Distributor:

Manufacturer:

METREL d.d.
Ljubljanska cesta 77
1354 Horjul
Slovenia
web site: <http://www.metrel.si>
e-mail: metrel@metrel.si



Mark on your equipment certifies that this equipment meets the requirements of the EU (European Union) concerning safety and electromagnetic compatibility regulations

© 2014 METREL

The trade names Metrel, Smartec, Eurotest, Autosequence are trademarks registered or pending in Europe and other countries.

No part of this publication may be reproduced or utilized in any form or by any means without permission in writing from METREL.

Table of contents

| | | |
|----------|---|-----------|
| 1 | Preface | 5 |
| 2 | Safety and operational considerations | 6 |
| 2.1 | Warnings and notes | 6 |
| 2.2 | Battery and charging | 9 |
| 2.2.1 | <i>New battery cells or cells unused for a longer period</i> | 10 |
| 2.3 | Standards applied | 10 |
| 3 | Instrument description | 12 |
| 3.1 | Front panel | 12 |
| 3.2 | Connector panel | 13 |
| 3.3 | Back side..... | 14 |
| 3.4 | Display organization | 15 |
| 3.4.1 | <i>Terminal voltage monitor</i> | 15 |
| 3.4.2 | <i>Battery indication</i> | 15 |
| 3.4.3 | <i>Message field</i> | 15 |
| 3.4.4 | <i>Result field</i> | 16 |
| 3.4.5 | <i>Sound warnings</i> | 16 |
| 3.4.6 | <i>Help screens</i> | 16 |
| 3.4.7 | <i>Backlight and contrast adjustments</i> | 17 |
| 4 | Instrument operation | 18 |
| 4.1 | Function selection | 18 |
| 4.2 | Settings | 19 |
| 4.2.1 | <i>Memory</i> | 19 |
| 4.2.2 | <i>Language</i> | 20 |
| 4.2.3 | <i>Date and time</i> | 20 |
| 4.2.4 | <i>RCD testing</i> | 20 |
| 4.2.5 | <i>Z factor</i> | 22 |
| 4.2.6 | <i>Commander support</i> | 22 |
| 4.2.7 | <i>Initial settings</i> | 23 |
| 5 | Measurements | 25 |
| 5.1 | Compensation of test leads resistance..... | 25 |
| 5.2 | Voltage, frequency and phase sequence | 26 |
| 5.3 | Insulation resistance..... | 28 |
| 5.4 | Continuity | 30 |
| 5.5 | Ring Continuity | 32 |
| 5.6 | Testing RCDs | 36 |
| 5.6.1 | <i>Contact voltage (RCD Uc)</i> | 37 |
| 5.6.2 | <i>Trip-out time (RCDt)</i> | 38 |
| 5.6.3 | <i>Trip-out current (RCD I)</i> | 39 |
| 5.6.4 | <i>RCD Autotest</i> | 39 |
| 5.7 | Fault loop impedance and prospective fault current | 42 |
| 5.8 | Line impedance and prospective short-circuit current / Voltage drop | 44 |
| 5.8.1 | <i>Line impedance and prospective short circuit current</i> | 45 |
| 5.8.2 | <i>Voltage drop</i> | 46 |
| 5.9 | Earth resistance | 48 |
| 5.10 | PE test terminal | 49 |
| 6 | Data handling | 51 |

| | | |
|----------|--|-----------|
| 6.1 | Memory organization | 51 |
| 6.2 | Data structure | 51 |
| 6.3 | Storing test results | 53 |
| 6.4 | Recalling test results | 54 |
| 6.5 | Clearing stored data | 55 |
| 6.5.1 | Clearing complete memory content | 55 |
| 6.5.2 | Clearing measurement(s) in selected location and its sub-locations | 55 |
| 6.5.3 | Clearing individual measurements | 56 |
| 6.5.4 | Renaming installation structure elements (upload from PC) | 57 |
| 6.5.5 | Renaming installation structure elements with serial barcode reader or RFID reader | 57 |
| 6.6 | Communication | 59 |
| 6.6.1 | USB and RS232 communication | 59 |
| 6.6.2 | Bluetooth communication | 60 |
| 7 | Maintenance | 61 |
| 7.1 | Fuse replacement | 61 |
| 7.2 | Cleaning | 61 |
| 7.3 | Periodic calibration | 61 |
| 7.4 | Upgrading the instrument | 61 |
| 7.5 | Service | 61 |
| 8 | Technical specifications | 62 |
| 8.1 | Insulation resistance (ISO L/N, ISO L/E, ISO N/E, ISO L/L) | 62 |
| 8.2 | Continuity & Ring (r_1 , r_2 , r_N , R_1+R_2 , R_1+R_N) | 62 |
| 8.3 | RCD testing | 63 |
| 8.3.1 | General data | 63 |
| 8.3.2 | Contact voltage RCD- U_c | 63 |
| 8.3.3 | Trip-out time | 63 |
| 8.3.4 | Trip-out current | 64 |
| 8.4 | Fault loop impedance and prospective fault current | 64 |
| 8.4.1 | No disconnecting device or FUSE selected | 64 |
| 8.4.2 | RCD selected | 65 |
| 8.5 | Line impedance and prospective short-circuit current / Voltage drop | 65 |
| 8.6 | Resistance to earth | 66 |
| 8.7 | Voltage, frequency, and phase rotation | 67 |
| 8.7.1 | Phase rotation | 67 |
| 8.7.2 | Voltage | 67 |
| 8.7.3 | Frequency | 67 |
| 8.7.4 | Online terminal voltage monitor | 67 |
| 8.8 | General data | 67 |
| A | Appendix A - Fuse table | 69 |
| A.1 | Fuse table - impedances (UK) | 69 |
| B | Appendix B - Accessories for specific measurements | 70 |
| C | Appendix C – Commanders (A 1314-UK, A 1401) | 71 |
| C.1 |  Warnings related to safety | 71 |
| C.2 | Battery | 71 |
| C.3 | Description of commanders | 72 |
| C.4 | Operation of commanders | 73 |

1 Preface

Congratulations on your purchase of the Eurotest instrument and its accessories from METREL. The instrument was designed on a basis of rich experience, acquired through many years of dealing with electric installation test equipment.

The Eurotest instrument is professional, multifunctional, hand-held test instrument intended to perform all the measurements required in order for a total inspection of electrical installations in buildings. The following measurements and tests can be performed:

- Voltage and frequency,
- Continuity tests,
- Insulation resistance tests,
- RCD testing,
- Fault loop / RCD trip-lock impedance measurements,
- Line impedance / Voltage drop,
- Earth test,
- Phase sequence,

The graphic display with backlight offers easy reading of results, indications, measurement parameters and messages. Two LED Pass/Fail indicators are placed at the sides of the LCD.

The operation of the instrument is designed to be as simple and clear as possible and no special training (except for the reading this instruction manual) is required in order to begin using the instrument.

In order for operator to be familiar enough with performing measurements in general and their typical applications it is advisable to read Metrel handbook *Guide for testing and verification of low voltage installations*.

The model MI 3125 BT has inbuilt Bluetooth interface for easy communication with PC and Android devices.

The instrument is equipped with the entire necessary accessory for comfortable testing.

2 Safety and operational considerations

2.1 Warnings and notes

In order to maintain the highest level of operator safety while carrying out various tests and measurements Metrel recommends keeping your Eurotest instruments in good condition and undamaged. When using the instrument, consider the following general warnings:

- ❑ The  symbol on the instrument means »Read the Instruction manual with special care for safe operation«. The symbol requires an action!
- ❑ If the test equipment is used in a manner not specified in this user manual, the protection provided by the equipment could be impaired!
- ❑ Read this user manual carefully, otherwise the use of the instrument may be dangerous for the operator, the instrument or for the equipment under test!
- ❑ Do not use the instrument or any of the accessories if any damage is noticed!
- ❑ If a fuse blows in the instrument, follow the instructions in this manual in order to replace it!
- ❑ Consider all generally known precautions in order to avoid risk of electric shock while dealing with hazardous voltages!
- ❑ Do not use the instrument in supply systems with voltages higher than 550 V!
- ❑ Service intervention or adjustment is only allowed to be carried out by a competent authorized personnel!
- ❑ Use only standard or optional test accessories supplied by your distributor!
- ❑ Consider that protection category of some accessories is lower than of the instrument. Test tips and Tip commander have removable caps. If they are removed the protection falls to CAT II. Check markings on accessories!
(cap off, 18 mm tip)...CAT II up to 1000 V
(cap on, 4 mm tip)... CAT II 1000 V / CAT III 600 V / CAT IV 300 V
- ❑ The instrument comes supplied with rechargeable Ni-Cd or Ni-MH battery cells. The cells should only be replaced with the same type as defined on the battery compartment label or as described in this manual. Do not use standard alkaline battery cells while the power supply adapter is connected, otherwise they may explode!
- ❑ Hazardous voltages exist inside the instrument. Disconnect all test leads, remove the power supply cable and switch off the instrument before opening the battery compartment.
- ❑ All normal safety precautions must be taken in order to avoid risk of electric shock while working on electrical installations!

Warnings related to measurement functions:

Insulation resistance

- ❑ Insulation resistance measurement should only be performed on de-energized objects!
- ❑ Do not touch the test object during the measurement or before it is fully discharged! Risk of electric shock!
- ❑ When an insulation resistance measurement has been performed on a capacitive object, automatic discharge may not be done immediately! The warning message  and the actual voltage is displayed during discharge until voltage drops below 10 V.
- ❑ Do not connect test terminals to external voltage higher than 600 V (AC or DC) in order not to damage the test instrument!

Continuity functions

- ❑ Continuity measurements should only be performed on de-energized objects!
- ❑ Parallel impedances or transient currents may influence test results.

Testing PE terminal

- ❑ If phase voltage is detected on the tested PE terminal, stop all measurements immediately and ensure the cause of the fault is eliminated before proceeding with any activity!

Notes related to measurement functions:

General

- ❑ The  indicator means that the selected measurement cannot be performed because of irregular conditions on input terminals.
- ❑ Insulation resistance and continuity functions can only be performed on de-energized objects.
- ❑ PASS / FAIL indication is enabled when limit is set. Apply appropriate limit value for evaluation of measurement results.
- ❑ In the case that only two of the three wires are connected to the electrical installation under test, only voltage indication between these two wires is valid.

Insulation resistance

- ❑ If voltages of higher than 10 V (AC or DC) is detected between test terminals, the insulation resistance measurement will not be performed. If voltages of higher than 10 V (AC or DC) is detected between test terminals, the insulation resistance measurement will not be performed.
- ❑ The instrument automatically discharge tested object after finished measurement.
- ❑ A double click of TEST key starts a continuous measurement.

Continuity functions

- If voltages of higher than 10 V (AC or DC) is detected between test terminals, the continuity resistance test will not be performed.
- Before performing a continuity measurement, where necessary, compensate test lead resistance.

RCD functions

- Parameters set in one function are also kept for other RCD functions!
- The measurement of contact voltage does not normally trip an RCD. However, the trip limit of the RCD may be exceeded as a result of leakage current flowing to the PE protective conductor or a capacitive connection between L and PE conductors.
- The RCD trip-lock sub-function (function selector switch in LOOP position) takes longer to complete but offers much better accuracy of fault loop resistance (in comparison to the R_L sub-result in Contact voltage function).
- RCD trip-out time and RCD trip-out current measurements will only be performed if the contact voltage in the pre-test at nominal differential current is lower than the set contact voltage limit!
- The autotest sequence (RCD AUTO function) stops when trip-out time is out of allowable time period.

Z-LOOP

- The low limit prospective short-circuit current value depends on fuse type, fuse current rating, fuse trip-out time and impedance scaling factor.
- The specified accuracy of tested parameters is valid only if the mains voltage is stable during the measurement.
- Fault loop impedance measurements will trip an RCD.
- The measurement of fault loop impedance using trip-lock function does not normally trip an RCD. However, the trip limit may be exceeded as a result of leakage current flowing to the PE protective conductor or a capacitive connection between L and PE conductors.

Z-LINE / VOLTAGE DROP

- In case of measurement of $Z_{\text{Line-Line}}$ with the instrument test leads PE and N connected together the instrument will display a warning of dangerous PE voltage. The measurement will be performed anyway.
- Specified accuracy of tested parameters is valid only if mains voltage is stable during the measurement.

2.2 Battery and charging

The instrument uses six AA size alkaline or rechargeable Ni-Cd or Ni-MH battery cells. Nominal operating time is declared for cells with nominal capacity of 2100 mAh.

Battery condition is always displayed in the lower right display part.

In case the battery is too weak the instrument indicates this as shown in *figure 2.1*. This indication appears for a few seconds and then the instrument turns itself off.

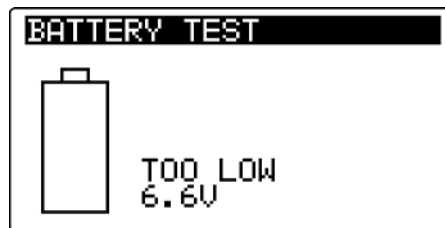

Figure 2.1: Discharged battery indication

The battery is charged whenever the power supply adapter is connected to the instrument. The power supply socket polarity is shown in *figure 2.2*. Internal circuit controls charging and assures maximum battery lifetime.



Figure 2.2: Power supply socket polarity

The instrument automatically recognizes the connected power supply adapter and begins charging.

Symbols:

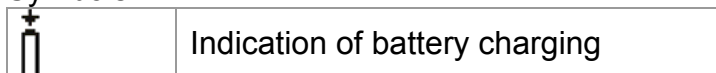

Figure 2.3: Charging indication

- ❑ When connected to an installation, the instruments battery compartment can contain hazardous voltage inside! When replacing battery cells or before opening the battery/fuse compartment cover, disconnect any measuring accessory connected to the instrument and turn off the instrument,
- ❑ Ensure that the battery cells are inserted correctly otherwise the instrument will not operate and the batteries could be discharged.
- ❑ If the instrument is not to be used for a long period of time, remove all batteries from the battery compartment.
- ❑ Alkaline or rechargeable Ni-Cd or Ni-MH batteries (size AA) can be used. Metrel recommends only using rechargeable batteries with a capacity of 2100mAh or above.
- ❑ Do not recharge alkaline battery cells!

- Use only power supply adapter delivered from the manufacturer or distributor of the test equipment to avoid possible fire or electric shock!

2.2.1 New battery cells or cells unused for a longer period

Unpredictable chemical processes can occur during the charging of new battery cells or cells that have been left unused for a longer period (more than 3 months). Ni-MH and Ni-Cd cells can be subjected to these chemical effects (sometimes called the memory effect). As a result the instrument operation time can be significantly reduced during the initial charging/discharging cycles of the batteries.

In this situation, Metrel recommend the following procedure to improve the battery lifetime:

| Procedure | Notes |
|---|--|
| ➤ Completely charge the battery. | At least 14h with in-built charger. |
| ➤ Completely discharge the battery. | This can be performed by using the instrument normally until the instrument is fully discharged. |
| ➤ Repeat the charge / discharge cycle at least 2-4 times. | Four cycles are recommended in order to restore the batteries to their normal capacity. |

Notes:

- The charger in the instrument is a pack cell charger. This means that the battery cells are connected in series during the charging. The battery cells have to be equivalent (same charge condition, same type and age).
- One different battery cell can cause an improper charging and incorrect discharging during normal usage of the entire battery pack (it results in heating of the battery pack, significantly decreased operation time, reversed polarity of defective cell,...).
- If no improvement is achieved after several charge / discharge cycles, then each battery cell should be checked (by comparing battery voltages, testing them in a cell charger, etc). It is very likely that only some of the battery cells are deteriorated.
- The effects described above should not be confused with the normal decrease of battery capacity over time. Battery also loses some capacity when it is repeatedly charged / discharged. Actual decreasing of capacity, versus number of charging cycles, depends on battery type. This information is provided in the technical specification from battery manufacturer.

2.3 Standards applied

The Eurotest instruments are manufactured and tested in accordance with the following regulations:

Electromagnetic compatibility (EMC)

| | |
|-------------|---|
| BS EN 61326 | Electrical equipment for measurement, control and laboratory use – EMC requirements Class B (Hand-held equipment used in controlled EM environments) |
|-------------|---|

Safety (LVD)

| | |
|-------------------|---|
| BS EN 61010-1 | Safety requirements for electrical equipment for measurement, control and laboratory use – Part 1: General requirements |
| BS EN 61010-031 | Safety requirements for hand-held probe assemblies for electrical measurement and test |
| BS EN 61010-2-030 | Safety requirements for electrical equipment for measurement, control, and laboratory use - Part 2-030: Particular requirements for testing and measuring circuits. |

Functionality

| | |
|-------------|---|
| BS EN 61557 | Electrical safety in low voltage distribution systems up to 1000 V _{AC} and 1500 V _{AC} – Equipment for testing, measuring or monitoring of protective measures Part 1 General requirements Part 2 Insulation resistance Part 3 Loop resistance Part 4 Resistance of earth connection and equipotential bonding Part 5 Resistance to earth Part 6 Residual current devices (RCDs) in TT and TN systems Part 7 Phase sequence Part 10 Combined measuring equipment |
|-------------|---|

Other reference standards for testing RCDs

| | |
|---------------|---|
| BS EN 61008 | Residual current operated circuit-breakers without integral overcurrent protection for household and similar uses |
| BS EN 61009 | Residual current operated circuit-breakers with integral overcurrent protection for household and similar uses |
| EN 60364-4-41 | Electrical installations of buildings Part 4-41 Protection for safety – protection against electric shock |
| EN 60364-5-52 | Low-voltage electrical installations – Part 5-52: Selection and erection of electrical equipment – Wiring systems |
| BS 7671 | IEE Wiring Regulations (17 th edition) |
| AS / NZ 3760 | In-service safety inspection and testing of electrical equipment |

Note about EN and IEC standards:

- Text of this manual contains references to European and British standards. All standards of EN 6XXXX (e.g. EN 61010) series are equivalent to IEC standards with the same number (e.g. IEC 61010) and differ only in amended parts required by European harmonization procedure.

3 Instrument description

3.1 Front panel



Figure 3.1: Front panel

Legend:

| | | |
|----|------------------------|--|
| 1 | LCD | 128 x 64 dots matrix display with backlight. |
| 2 | TEST | TEST Starts measurements. TEST Acts also as the PE touching electrode. |
| 3 | UP | Modifies selected parameter. |
| 4 | DOWN | |
| 5 | MEM | Store / recall / clear tests in memory of instrument. |
| 6 | Function selectors | Selects test function. |
| 7 | Backlight, Contrast | Changes backlight level and contrast. |
| 8 | ON / OFF | Switches the instrument power on or off. <i>The instrument automatically turns off 15 minutes after the last key was pressed.</i> In RCD Auto toggles between top and bottom parts of results field. |
| 9 | HELP CAL | Accesses help menus. Calibrates test leads in Continuity functions. Starts Z _{REF} measurement in Voltage drop sub-function. |
| 10 | TAB | Selects the parameters in selected function. |
| 11 | PASS | Green indicator |
| 12 | FAIL | Red indicator |

3.2 Connector panel

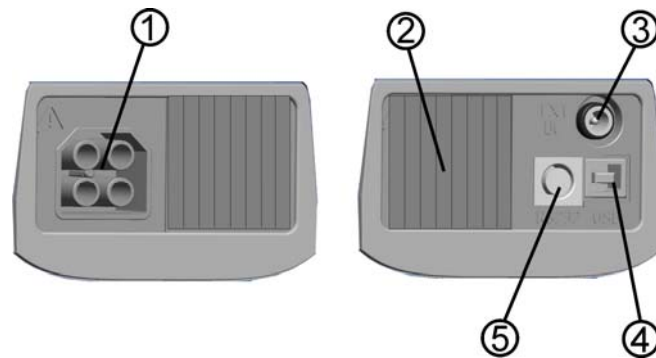

Figure 3.2: Connector panel

Legend:

| | | |
|---|------------------|--|
| 1 | Test connector | Measuring inputs / outputs |
| 2 | Protection cover | |
| 3 | Charger socket | |
| 4 | USB connector | Communication with PC USB (1.1) port. |
| 5 | PS/2 connector | Communication with PC serial port and connection to optional accessories. Serial port for upgrading the instrument. |

Warnings!

- ❑ **Maximum allowed voltage between any test terminal and ground is 600 V!**
- ❑ **Maximum allowed voltage between test terminals is 600 V!**
- ❑ **Maximum short-term voltage of external power supply adapter is 14 V!**

3.3 Back side



Figure 3.3: Back side

Legend:

| | |
|---|--|
| 1 | Side belt |
| 2 | Battery compartment cover |
| 3 | Fixing screw for battery compartment cover |
| 4 | Back panel information label |
| 5 | Holder for inclined position of the instrument |
| 6 | Magnet for fixing instrument close to tested item (optional) |

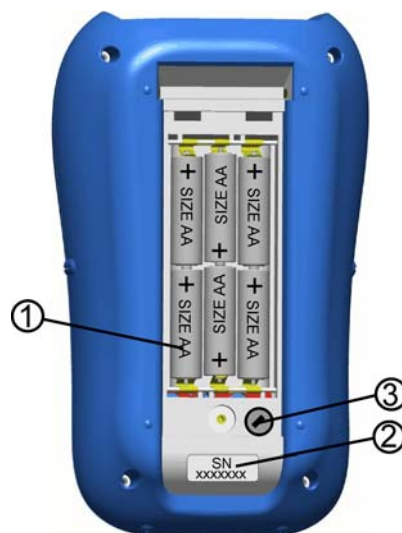

Figure 3.4: Battery compartment

Legend:

| | | |
|---|---------------------|---|
| 1 | Battery cells | Size AA, alkaline or rechargeable NiMH / NiCd |
| 2 | Serial number label | |
| 3 | Fuse | M 0.315 A, 250 V |

3.4 Display organization

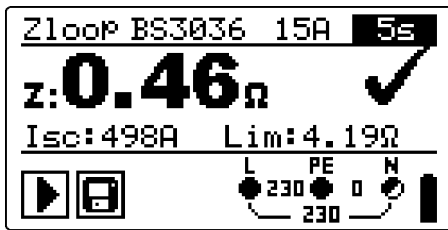

Figure 3.5: Typical function display

| | |
|----------------------|--------------------------|
| | Function name |
| z: 0.46 Ω ✓ | Result field |
| Isc: 498A Lim: 4.19Ω | Test parameter field |
| BS3036 15A 5s | Message field |
| | Terminal voltage monitor |
| | Battery indication |

3.4.1 Terminal voltage monitor

The terminal voltage monitor displays on-line the voltages on the test terminals and information about active test terminals.

| | |
|--|---|
| | Online voltages are displayed together with test terminal indication. All three test terminals are used for selected measurement. |
| | Online voltages are displayed together with test terminal indication. L and N test terminals are used for selected measurement. |
| | L and PE are active test terminals; N terminal should also be connected for correct input voltage condition. |

3.4.2 Battery indication











The indication indicates the charge condition of battery and connection of external charger .

| | |
|--|---|
| | Battery capacity indication. |
| | Low battery. Battery is too weak to guarantee correct result. Replace or recharge the battery cells. |
| | Recharging in progress (if power supply adapter is connected). |



3.4.3 Message field

In the message field warnings and messages are displayed.

| | |
|--|--|
| | Measurement is running, consider displayed warnings. |
| | Conditions on the input terminals allow starting the measurement; consider other displayed warnings and messages. |
| | Conditions on the input terminals do not allow starting the measurement, consider displayed warnings and messages. |

| | |
|---|---|
|  | RCD tripped-out during the measurement (in RCD functions). |
|  | Instrument is overheated. The measurement is prohibited until the temperature decreases under the allowed limit. |
|  | Result(s) can be stored. |
|  | High electrical noise was detected during measurement. Results may be impaired. |
|  | L and N are changed. |
|  | Warning! High voltage is applied to the test terminals. |
|  | Warning! Dangerous voltage on the PE terminal! Stop the activity immediately and eliminate the fault / connection problem before proceeding with any activity! |
|  | High resistance to earth of test probes. Results may be impaired. |
|  | Test leads resistance in Continuity measurement is not compensated. |
|  | Test leads resistance in Continuity measurement is compensated. |
|  | Fuse F1 is broken. |

3.4.4 Result field

| | |
|---|---|
|  | Measurement result is inside pre-set limits (PASS). |
|  | Measurement result is out of pre-set limits (FAIL). |
|  | Measurement is aborted. Consider displayed warnings and messages. |

3.4.5 Sound warnings

Continuous sound **Warning!** Dangerous voltage on the PE terminal is detected.

3.4.6 Help screens

| | |
|-------------|--------------------|
| HELP | Opens help screen. |
|-------------|--------------------|

Help menus are available in all functions. The Help menu contains schematic diagrams for illustrating how to properly connect the instrument to electric installation. After selecting the measurement you want to perform, press the HELP key in order to view the associated Help menu.

Keys in help menu:

| | |
|------------------|--------------------------------------|
| UP / DOWN | Selects next / previous help screen. |
| HELP | Scrolls through help screens. |

| | |
|----------------------------------|------------------|
| Function selectors / TEST | Exits help menu. |
|----------------------------------|------------------|

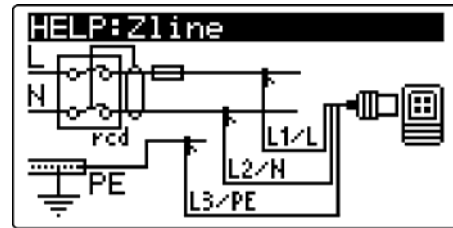
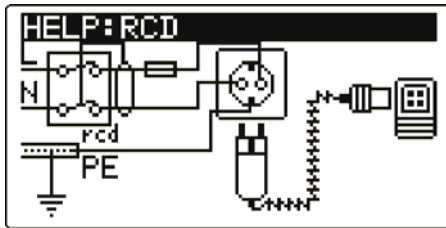

Figure 3.6: Examples of help screens

3.4.7 Backlight and contrast adjustments

With the **BACKLIGHT** key backlight and contrast can be adjusted.

| | |
|-----------------------------|---|
| Click | Toggles backlight intensity level. |
| Keep pressed for 1 s | Locks high intensity backlight level until power is turned off or the key is pressed again. |
| Keep pressed for 2 s | Bargraph for LCD contrast adjustment is displayed. |



Figure 3.7: Contrast adjustment menu

Keys for contrast adjustment:

| | |
|---------------------------|------------------------|
| DOWN | Reduces contrast. |
| UP | Increases contrast. |
| TEST | Accepts new contrast. |
| Function selectors | Exits without changes. |

4 Instrument operation

4.1 Function selection

For selecting test function the **FUNCTION SELECTOR** shall be used.

Keys:

| | |
|--------------------------|---|
| FUNCTION SELECTOR | Select test / measurement function: <ul style="list-style-type: none"> <input type="checkbox"/> <VOLTAGE TRMS> Voltage and frequency and phase sequence. <input type="checkbox"/> <R ISO> Insulation resistance. <input type="checkbox"/> <Continuity> Continuity of earth connections and bondings <input type="checkbox"/> <Zline> Line impedance. <input type="checkbox"/> <Zloop> Fault loop impedance. <input type="checkbox"/> <RCD> RCD testing. <input type="checkbox"/> <EARTH RE> Resistance to earth. <input type="checkbox"/> <SETTINGS> General instrument settings. |
| UP/DOWN | Selects sub-function in selected measurement function. |
| TAB | Selects the test parameter to be set or modified. |
| TEST | Runs selected test / measurement function. |
| MEM | Stores measured results / recalls stored results. |

Keys in **test parameter** field:

| | |
|--------------------------|---|
| UP/DOWN | Changes the selected parameter. |
| TAB | Selects the next measuring parameter. |
| FUNCTION SELECTOR | Toggles between the main functions. |
| MEM | Stores measured results / recalls stored results. |

General rule regarding enabling **parameters** for evaluation of measurement / test result:

| | | |
|-----------|------------|---|
| Parameter | OFF | No limit values, indication: <u> </u> . |
| | ON | Value(s) – results will be marked as PASS or FAIL in accordance with selected limit. |

See *chapter 5* for more information about the operation of the instrument test functions.

4.2 Settings

Different instrument options can be set in the **SETTINGS** menu.

- ❑ Selection of language,
- ❑ Setting the instrument to initial values,
- ❑ Selection of reference standard for RCD test,
- ❑ Entering Z factor,
- ❑ Commander support.
- ❑ Recalling and clearing stored results,
- ❑ Setting the date and time

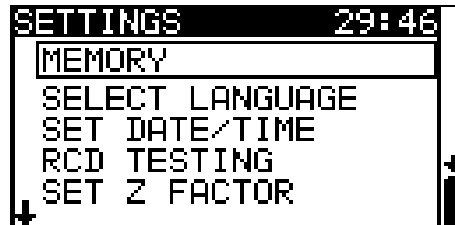

Figure 4.1: Options in Settings menu

Keys:

| | |
|---------------------------|-----------------------------------|
| UP / DOWN | Selects appropriate option. |
| TEST | Enters selected option. |
| Function selectors | Exits back to main function menu. |

4.2.1 Memory

In this menu the stored data can be recalled and deleted. See chapter 6 *Data handling* for more information.

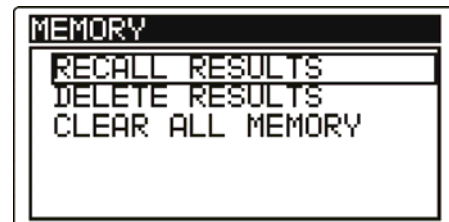

Figure 4.2: Memory options

Keys:

| | |
|---------------------------|-----------------------------------|
| UP / DOWN | Selects option. |
| TEST | Enters selected option. |
| Function selectors | Exits back to main function menu. |

4.2.2 Language

In this menu the language can be set.

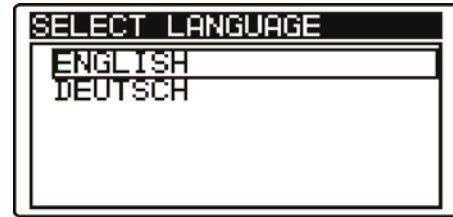

Figure 4.3: Language selection

Keys:

| | |
|---------------------------|--|
| UP / DOWN | Selects language. |
| TEST | Confirms selected language and exits to settings menu. |
| Function selectors | Exits back to main function menu. |

4.2.3 Date and time

In this menu date and time can be set.



Figure 4.4: Setting date and time

Keys:

| | |
|---------------------------|-----------------------------------|
| TAB | Selects the field to be changed. |
| UP / DOWN | Modifies selected field. |
| TEST | Confirms new setup and exits. |
| Function selectors | Exits back to main function menu. |

Warning:

- If the batteries are removed for more than 1 minute the set time and date will be lost.

4.2.4 RCD testing

In this menu the used standard for RCD tests can be set.

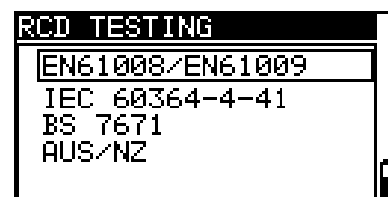

Figure 4.5: Selection of RCD test standard

Keys:

| | |
|---------------------------|-----------------------------------|
| UP / DOWN | Selects standard. |
| TEST | Confirms selected standard. |
| Function selectors | Exits back to main function menu. |

Maximum RCD disconnection times differ in various standards.

The trip-out times defined in individual standards are listed below.

Trip-out times according to EN 61008 / EN 61009:

| | $\frac{1}{2} \times I_{\Delta N}^*$ | $I_{\Delta N}$ | $2 \times I_{\Delta N}$ | $5 \times I_{\Delta N}$ |
|-------------------------------|-------------------------------------|----------------------------------|---------------------------------|---------------------------------|
| General RCDs (non-delayed) | $t_{\Delta} > 300$ ms | $t_{\Delta} < 300$ ms | $t_{\Delta} < 150$ ms | $t_{\Delta} < 40$ ms |
| Selective RCDs (time-delayed) | $t_{\Delta} > 500$ ms | 130 ms $< t_{\Delta} < 500$ ms | 60 ms $< t_{\Delta} < 200$ ms | 50 ms $< t_{\Delta} < 150$ ms |

Trip-out times according to EN 60364-4-41:

| | $\frac{1}{2} \times I_{\Delta N}^*$ | $I_{\Delta N}$ | $2 \times I_{\Delta N}$ | $5 \times I_{\Delta N}$ |
|-------------------------------|-------------------------------------|----------------------------------|---------------------------------|---------------------------------|
| General RCDs (non-delayed) | $t_{\Delta} > 999$ ms | $t_{\Delta} < 999$ ms | $t_{\Delta} < 150$ ms | $t_{\Delta} < 40$ ms |
| Selective RCDs (time-delayed) | $t_{\Delta} > 999$ ms | 130 ms $< t_{\Delta} < 999$ ms | 60 ms $< t_{\Delta} < 200$ ms | 50 ms $< t_{\Delta} < 150$ ms |

Trip-out times according to BS 7671:

| | $\frac{1}{2} \times I_{\Delta N}^*$ | $I_{\Delta N}$ | $2 \times I_{\Delta N}$ | $5 \times I_{\Delta N}$ |
|-------------------------------|-------------------------------------|----------------------------------|---------------------------------|---------------------------------|
| General RCDs (non-delayed) | $t_{\Delta} > 1999$ ms | $t_{\Delta} < 300$ ms | $t_{\Delta} < 150$ ms | $t_{\Delta} < 40$ ms |
| Selective RCDs (time-delayed) | $t_{\Delta} > 1999$ ms | 130 ms $< t_{\Delta} < 500$ ms | 60 ms $< t_{\Delta} < 200$ ms | 50 ms $< t_{\Delta} < 150$ ms |

Trip-out times according to AS/NZ**):

| RCD type | $I_{\Delta N}$ [mA] | $\frac{1}{2} \times I_{\Delta N}^*$ t_{Δ} | $I_{\Delta N}$ t_{Δ} | $2 \times I_{\Delta N}$ t_{Δ} | $5 \times I_{\Delta N}$ t_{Δ} | Note |
|--------------|---------------------|---|--------------------------------|---|---|----------------------------|
| I | ≤ 10 | > 999 ms | 40 ms | 40 ms | 40 ms | Maximum break time |
| II | $> 10 \leq 30$ | | 300 ms | 150 ms | 40 ms | |
| III | > 30 | | 300 ms | 150 ms | 40 ms | |
| IV \square | > 30 | > 999 ms | 500 ms | 200 ms | 150 ms | Minimum non-actuating time |
| | | | 130 ms | 60 ms | 50 ms | |

*) Minimum test period for current of $\frac{1}{2} \times I_{\Delta N}$, RCD shall not trip-out.

**) Test current and measurement accuracy correspond to AS/NZ requirements.

Maximum test times related to selected test current for general (non-delayed) RCD

| Standard | $\frac{1}{2} \times I_{\Delta N}$ | $I_{\Delta N}$ | $2 \times I_{\Delta N}$ | $5 \times I_{\Delta N}$ |
|---------------------|-----------------------------------|----------------|-------------------------|-------------------------|
| EN 61008 / EN 61009 | 300 ms | 300 ms | 150 ms | 40 ms |
| EN 60364-4-41 | 1000 ms | 1000 ms | 150 ms | 40 ms |
| BS 7671 | 2000 ms | 300 ms | 150 ms | 40 ms |
| AS/NZ (I, II, III) | 1000 ms | 1000 ms | 150 ms | 40 ms |

Maximum test times related to selected test current for selective (time-delayed) RCD

| Standard | $\frac{1}{2} \times I_{\Delta N}$ | $I_{\Delta N}$ | $2 \times I_{\Delta N}$ | $5 \times I_{\Delta N}$ |
|---------------------|-----------------------------------|----------------|-------------------------|-------------------------|
| EN 61008 / EN 61009 | 500 ms | 500 ms | 200 ms | 150 ms |
| EN 60364-4-41 | 1000 ms | 1000 ms | 200 ms | 150 ms |

| | | | | |
|------------|---------|---------|--------|--------|
| BS 7671 | 2000 ms | 500 ms | 200 ms | 150 ms |
| AS/NZ (IV) | 1000 ms | 1000 ms | 200 ms | 150 ms |
| | | | | |

4.2.5 Z factor

The impedance limit values for different overcurrent protective devices are scaled down by a factor 0,8 or 0,75 (Z factor). This means that the fault current will still be high enough also at increased conductor temperatures and low supply voltage. This assures a safe operation of the overcurrent protection device in all conditions.

In this menu the Z factor can be set.

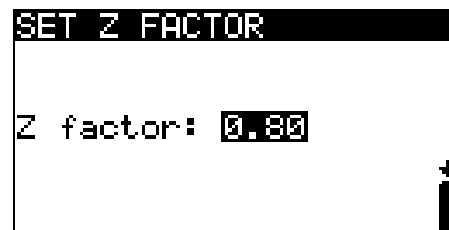

Figure 4.6: Selection of Z factor

Keys:

| | |
|---------------------------|-----------------------------------|
| UP / DOWN | Sets Z value. |
| TEST | Confirms Z value. |
| Function selectors | Exits back to main function menu. |

4.2.6 Commander support

The support for commanders can be set in this menu.

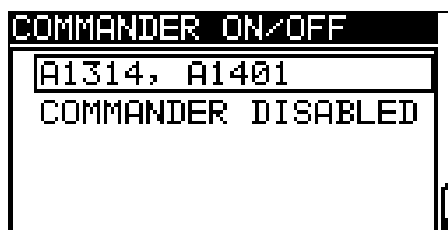

Figure 4.7: Selection of commander support

Keys:

| | |
|---------------------------|---|
| UP / DOWN | Selects commander model. Disables commander support. |
| TEST | Confirms selected option. |
| Function selectors | Exits back to main function menu. |

Commander models

- A1314, A1401: new commanders (more information can be found in Appendix C)

Note:

- Commander disabled option is intended to disable the commander's remote keys. In the case of high EM interfering noise the operation of the commander's key can be irregular.

4.2.7 Initial settings

In this menu the instrument settings and measurement parameters and limits can be set to initial (factory) values and internal Bluetooth module is initialized.

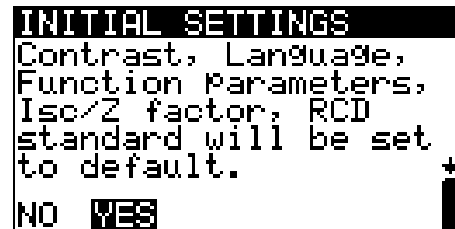

Figure 4.8: Initial settings dialogue

Keys:

| | |
|---------------------------|---|
| TEST | Restores default settings (YES must be selected with Δ/∇ keys). |
| Function selectors | Exits back to main function menu without changes. |

Warning:

- Customized settings will be lost when this option is used!
- If the batteries are removed for more than 1 minute the custom made settings will be lost.

The default setup is listed below:

| Instrument setting | Default value |
|--------------------|---|
| Contrast | As defined and stored by adjustment procedure |
| Z factor | 0.8 |
| RCD standards | EN 61008 / EN 61009 |
| Language | English |
| Commander | A1314, A1401 |
| Internal bluetooth | Initialization of internal Bluetooth module. |

| Function Sub-function | Parameters / limit value |
|--|--|
| EARTH RE | No limit |
| R ISO L/N, L/E, N/E, L/L | No limit $U_{test} = 500 \text{ V}$ |
| CONTINUITY r1,rN,r2, R2, R1+R2, R1+RN | No limit |
| Z - LINE VOLTAGE DROP | Fuse type: none selected $\Delta U: 4.0 \%$ $Z_{REF}: 0.00 \Omega$ |

| | |
|-------------------|--|
| Z - LOOP | Fuse type: none selected |
| Zs _{rcd} | Fuse type: none selected |
| RCD | RCD t Nominal differential current: I _{ΔN} =30 mA RCD type: <input type="checkbox"/> non-delayed Test current starting polarity:  (0°) Limit contact voltage: 50 V Current multiplier: ×1 |

Note:

- Initial settings (reset of the instrument) can be recalled also if the TAB key is pressed while the instrument is switched on.

5 Measurements

5.1 Compensation of test leads resistance

This chapter describes how to compensate the test leads resistance in Continuity function. Compensation is required to eliminate the influence of test leads resistance and the internal resistances of the instrument on the measured resistance. The lead compensation is therefore very important to obtain correct result. There are two separated calibration values:

- one for r_1 , r_N , r_2 , R_1+R_2 and R_2 ,
- one for R_1+R_N .

The  symbol is displayed in the Continuity message fields if the compensation was carried out successfully.

Circuits for compensating the resistance of test leads

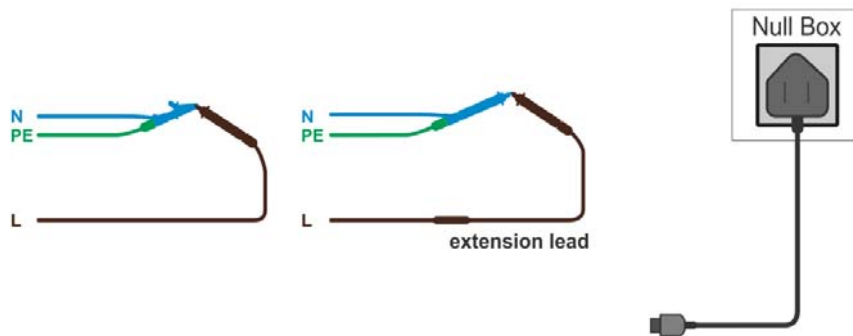

Figure 5.1: Shorted test leads

Compensation of test leads resistance procedure

- ❑ Select **Continuity** function.
- ❑ **Connect** test cable to the instrument and short the test leads together appropriately (see figure 5.1).
- ❑ Press **CAL** key to perform test lead compensation.
- ❑ If the leads were successfully calibrated the resistance with old calibration data is displayed first and 0.00Ω afterwards.

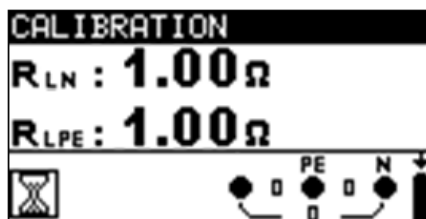

Figure 5.2: Results with old calibration values

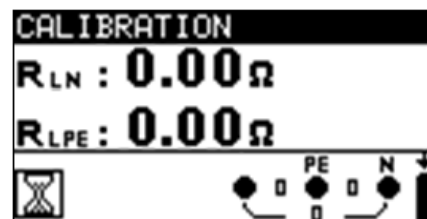

Figure 5.3: Results with new calibration values

Note:

- The highest value for lead compensation is 5 Ω . If the resistance is higher the compensation value is set back to default value.



is displayed if no calibration value is stored.

5.2 Voltage, frequency and phase sequence

In the special **VOLTAGE TRMS** menu the measured voltage, frequency and information about detected three-phase connection are displayed. Phase sequence measurement conforms to the EN 61557-7 standard.

See chapter 4.1 *Function selection* for instructions on key functionality.

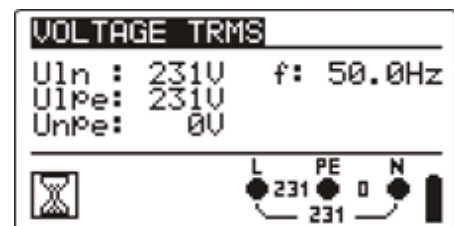

Figure 5.4: Voltage in single phase system

Test parameters for voltage measurement

There are no parameters to set.

Connections for voltage measurement

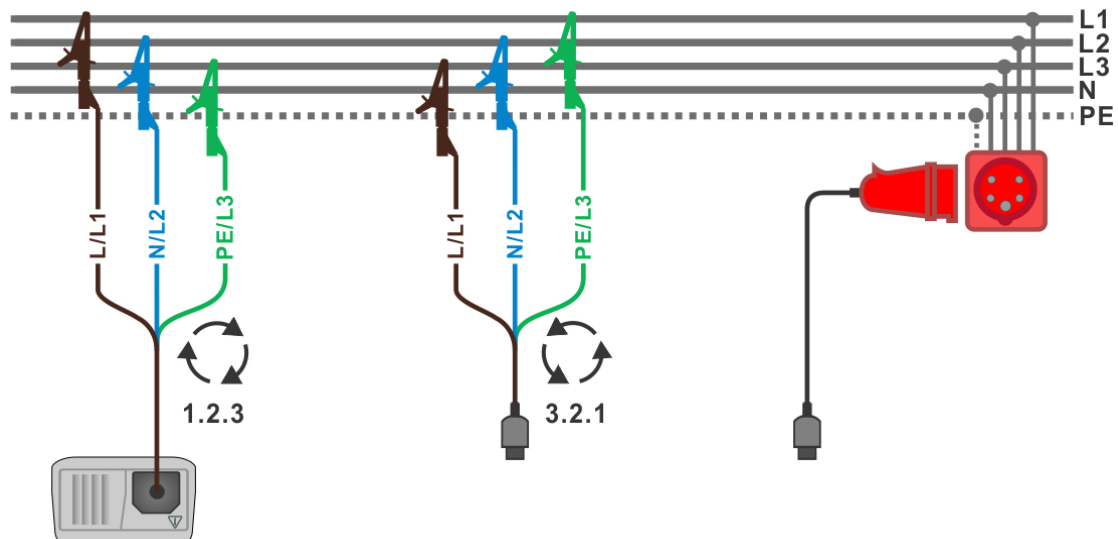

Figure 5.5: Connection of universal test cable and optional adapter in three-phase system

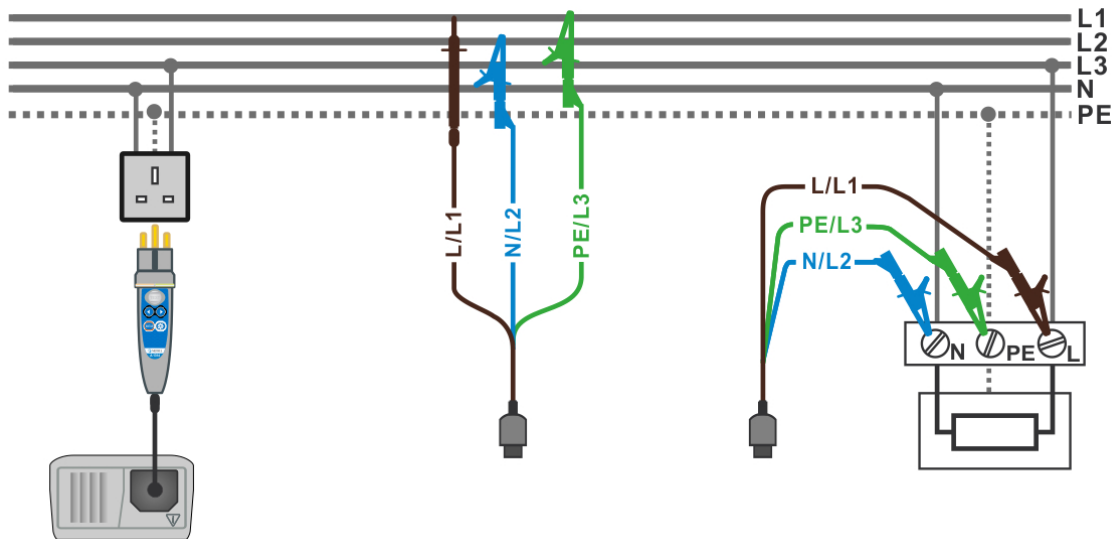

Figure 5.6: Connection of plug cable or commander and universal test cable in single-phase system

Voltage measurement procedure

- ❑ Select the **VOLTAGE TRMS** function using the function selector switch.
- ❑ **Connect** test cable to the instrument.
- ❑ **Connect** test leads to the item to be tested (see figures 5.5 and 5.6).
- ❑ **Store** voltage measurement result by pressing the MEM key (optional).

Measurement runs immediately after selection of **VOLTAGE TRMS** function.



Figure 5.7: Examples of voltage measurement in three-phase system

Displayed results for single phase system:

U_{In}..... Voltage between phase and neutral conductors,
 U_{Ipe}..... Voltage between phase and protective conductors,
 U_{Ne}..... Voltage between neutral and protective conductors,
 f..... frequency.

Displayed results for three-phase system:

U₁₂..... Voltage between phases L1 and L2,
 U₁₃..... Voltage between phases L1 and L3,
 U₂₃..... Voltage between phases L2 and L3,
 1.2.3 Correct connection – CW rotation sequence,
 3.2.1 Invalid connection – CCW rotation sequence,
 f..... frequency.

5.3 Insulation resistance

The Insulation resistance measurement is performed in order to ensure safety against electric shock through insulation. It is covered by the EN 61557-2 standard. Typical applications are:

- Insulation resistance between conductors of installation,
- Insulation resistance of non-conductive rooms (walls and floors),
- Insulation resistance of ground cables,
- Resistance of semi-conductive (antistatic) floors.

Four Insulation resistance sub-functions are available:

- ISO L/E,
- ISO L/N
- ISO L/L
- ISO N/E

The insulation resistance tests are carried out in the same way regardless which sub-function is selected. However it is important to select the appropriate sub-function in order to classify the measurement to be correctly considered in verification documents (Electrical Installation Certificate, Periodic Inspection Report etc.).

See chapter 4.1 *Function selection* for instructions on key functionality.



Figure 5.8: Insulation resistance

Test parameters for insulation resistance measurement

| | |
|-------------|--|
| Measurement | Subfunction [ISO L/E, ISO L/N, ISO N/E, ISO L/L] |
| Uiso | Test voltage [50 V, 100 V, 250 V, 500 V, 1000 V] |
| Limit | Minimum insulation resistance [OFF, 0.01 MΩ ÷ 200 MΩ] |

Test circuits for insulation resistance

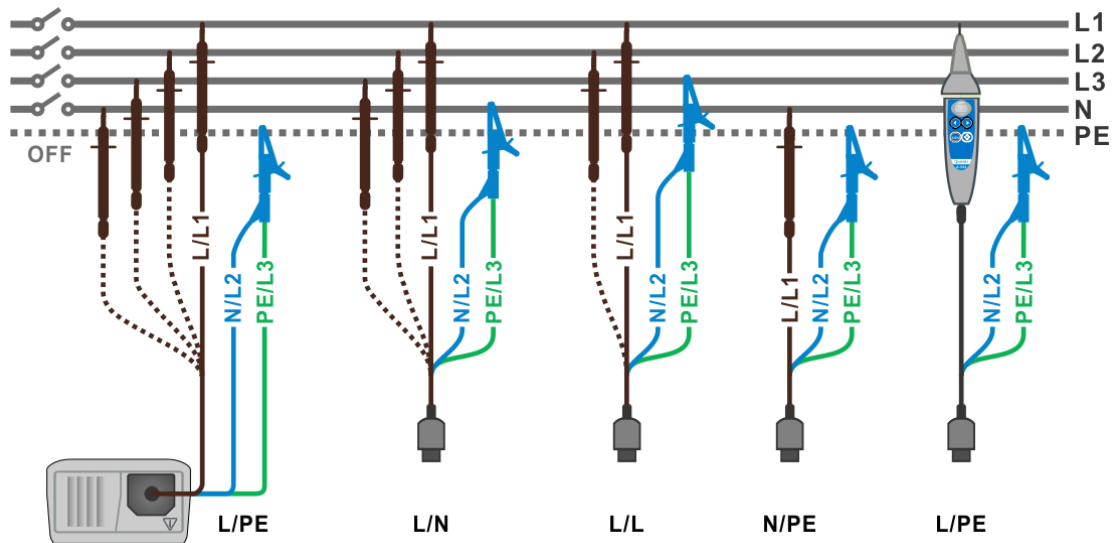

Figure 5.9: Connections for insulation measurement

Insulation resistance measuring procedure

- ❑ Select the **INS** function using the function selector switch.
- ❑ Select the insulation subfunction with $\blacktriangle/\blacktriangledown$ keys.
- ❑ Set the required **test voltage**.
- ❑ Enable and set **limit** value (optional).
- ❑ **Disconnect** tested installation from mains supply (and discharge insulation as required).
- ❑ **Connect** test cable to the instrument and to the item to be tested (see Fig. 5.9).
- ❑ Press the **TEST** key to perform the measurement (double click for continuous measurement and later press to stop the measurement).
- ❑ After the measurement is finished wait until tested item is fully discharged.
- ❑ **Store** the result by pressing the MEM key (optional).

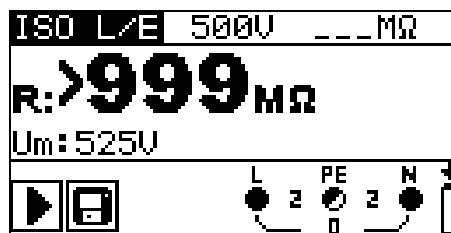

Figure 5.10: Example of insulation resistance measurement result

Displayed results:

R.....Insulation resistance
Um.....Test voltage – actual value.

5.4 Continuity

The Continuity measurement is performed in order to ensure that the protective measures against electric shock through earthing connections and bondings are effective. Six continuity sub-functions are available:

- r_1 ,
- r_N
- r_2
- R_1+R_2
- R_2
- R_1+R_N

It is important to select the appropriate sub-function in order to classify the measurement to be correctly considered in verification documents (Electrical Installation Certificate, Periodic Inspection Report etc.). The r_1 , r_N , r_2 , R_1+R_2 and R_2 continuity tests are carried out between L and PE terminals in the same way regardless of which sub-function is selected. The R_1+R_N continuity test is carried out between L and N terminals.

See chapter 4.1 *Function selection* for instructions on key functionality.

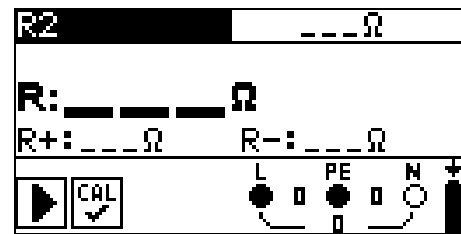

Figure 5.11: Example R_2

Test parameters for Continuity measurement

| | |
|-------------|--|
| Measurement | Subfunction [r_1 , r_2 , r_N , R_2 , R_1+R_2 , R_1+R_N] |
| Limit | Maximum resistance [OFF, 0.1 Ω ÷ 20.0 Ω] |

The Continuity measurement is performed with automatic polarity reversal of the test voltage according to IEC/EN 61557-4.

Test circuits for Continuity measurement

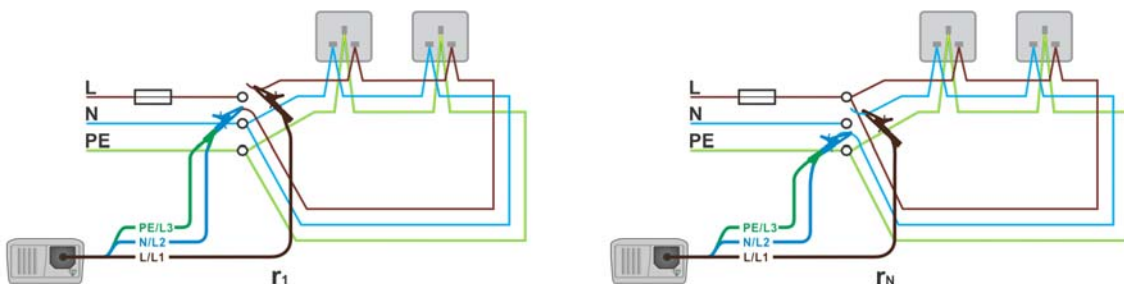

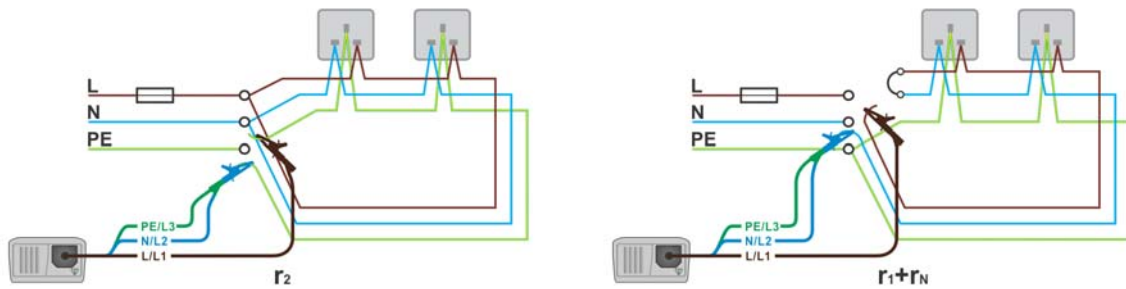

Figure 5.12: Connections for testing the r_1 , r_N , r_2 and R_1+R_N sections of the wiring in ring circuits

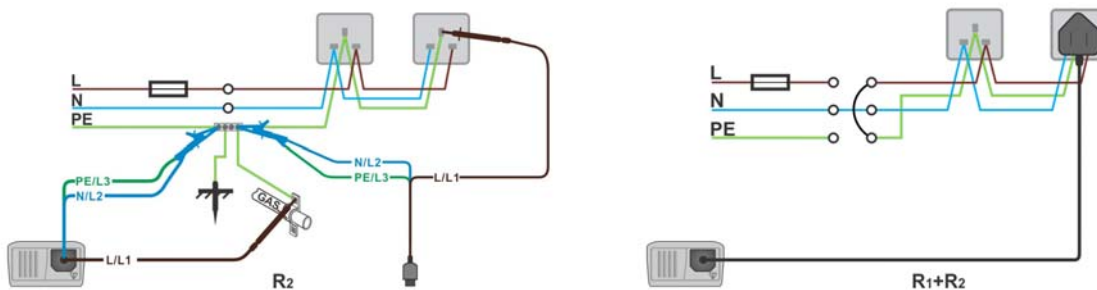

Figure 5.13: Connections for testing the R_2 and R_1+R_2 sections of the wiring in final circuits

Continuity measurement procedure

- ❑ Select **Continuity** function using the function selector switch.
- ❑ Set sub-function with $\blacktriangle/\blacktriangledown$ keys
- ❑ Enable and set **limit** (optional).
- ❑ **Connect** test cable to the instrument.
- ❑ **Compensate** the test leads resistance (if necessary, see section 5.3.1).
- ❑ **Disconnect** tested installation from mains supply.
- ❑ **Connect** the test leads to the appropriate PE wiring (see figures 5.12 and 5.13).
- ❑ Press the **TEST** key to perform the measurement.
- ❑ After the measurement is finished **store** the result by pressing the MEM button (optional).



Figure 5.14: Example of Continuity result

Displayed result:

R.....Continuity result
 R+.....Result at positive polarity
 R-.....Result at negative test polarity

5.5 Ring Continuity

With Easy Switch A1214 the resistance measurements in final ring circuits can be simplified. The Easy Switch cares for correct connectivity at the switchboard. r_1 , r_N , r_2 or R_1+R_2 , R_1+R_N measurements can be performed in one go.

See chapter 4.1 *Function selection* for instructions on key functionality.

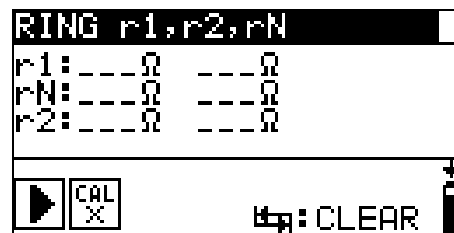

Figure 5.15: Ring Continuity r_1 , r_N , r_2

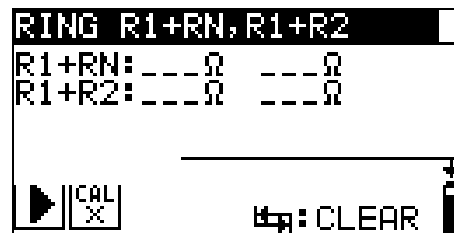

Figure 5.16: Ring Continuity R_1+R_2 , R_1+R_N

Test parameters for Ring Continuity measurement

| Measurement | Subfunction [(r_1 , r_2 , r_N), (R_1+R_2 , R_1+R_N)] |
|-------------|--|
|-------------|--|

The Ring Continuity measurement is performed with automatic polarity reversal of the test voltage according to IEC/EN 61557-4.

Test circuits for Ring Continuity measurement

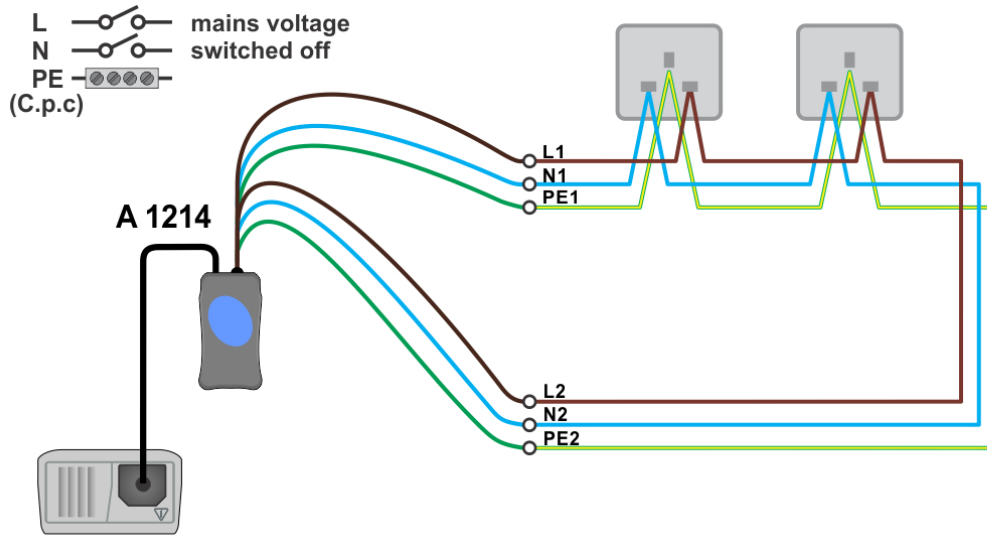

Figure 5.17: Step 1 - measurement of resistances r_1 , r_N and r_2

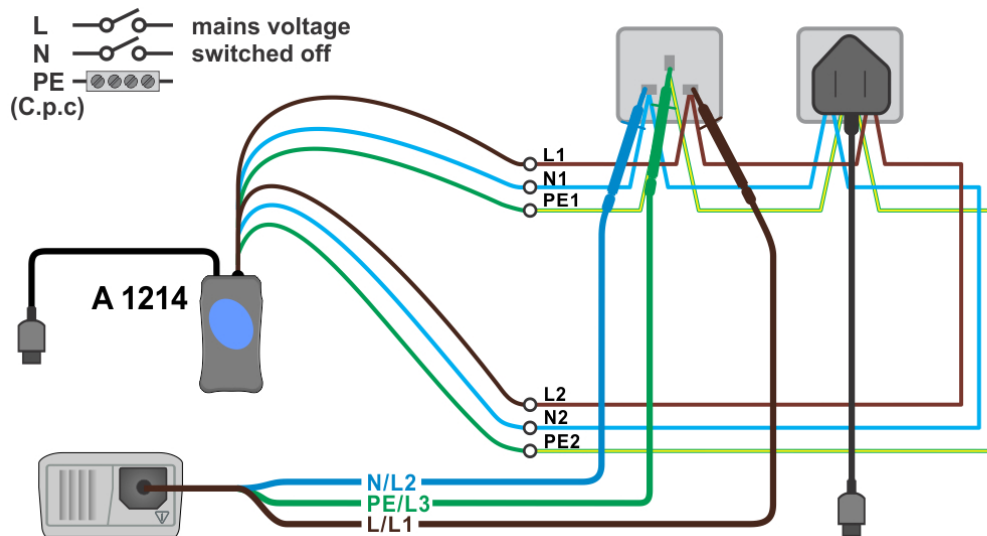

Figure 5.18: Step 2 - measurement of resistances R_1+R_2 , R_1+R_N

Ring Continuity measuring procedure**Step 1: r₁, r_N, r₂ resistance measuring procedure**

- ❑ Select the **RING** function.
- ❑ Set sub-function **r1, rN, r2**
- ❑ **Compensate** test leads resistance (if necessary, see chapter 5.1).
- ❑ **Connect Easy Switch** to the instrument (see figure 5.17)
- ❑ **Connect Easy switch** to the final ring circuit. The electrical installation must be de-energized during the test (see figure 5.17).
- ❑ Press the **TEST** key to perform the measurement.
- ❑ Perform measurements of r₁, r_N, and r₂.
- ❑ **Commit results** (TAB key) to r₁, r_N, and r₂.
- ❑ The r₁, r_N, r₂ **results can be cleared** with the TAB key
- ❑ **Store** the results (optional).

From r₁, r_N and r₂ results reference values $(R_1+R_N)/4$, $(R_1+R_2)/4$ are calculated. The results are kept until they are changed or cleared. Take care that measuring leads are compensated.

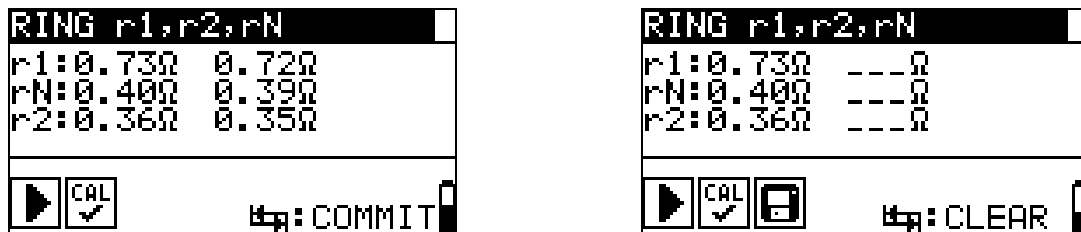

Figure 5.19: Examples of Ring Continuity test – Step 1

Displayed results:

- r1 Ring resistance of line conductors (committed and measured)
- rN Ring resistance of neutral conductors (committed and measured)
- r2 Ring resistance of protective conductors (committed and measured)

Step 2: R₁+R_N, R₁+R₂ resistance measuring procedure

- ❑ **Easy switch** must stay connected to the final ring circuit. The electrical installation must be de-energized during the test (see figure 5.18).
- ❑ Select the **RING** function.
- ❑ Set sub-function **R1+RN, R1+R2**
- ❑ **Connect** plug cable or test cable to the instrument.
- ❑ **Compensate** test leads resistance (if necessary, see chapter 5.1).
- ❑ **Connect** plug cable or test cable to a socket in final ring circuit.
- ❑ Press the **TEST** key for measurements.
- ❑ For correct ring wiring the results must be approximately the same as reference value $(r_1+r_N)/4$ and $(r_1+r_2)/4$. The resistance R₁+R₂ slightly increases with length if cross-section of PE conductor is smaller than of line conductor.
- ❑ **Commit results** (TAB key) to R₁+R_N and R₁+R₂ positions.
- ❑ Perform measurement on the next socket in final ring circuit.
- ❑ **Commit results** (TAB key) again. The results will be committed only if they are

- higher as the previous results.
- The R1+RN and R1+R2 **results can be cleared** with the TAB key
 - Repeat the measurement on all sockets of the final ring circuit.
 - The R1+RN and R1+R2 **results can be cleared** with the TAB key
 - After the measurements are finished, **store** the result (optional).

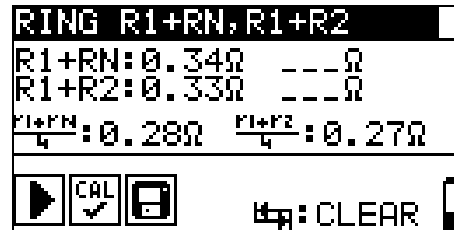
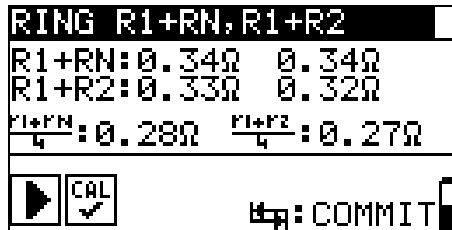

Figure 5.20: Examples of Ring Continuity test – step 2

Displayed results:

- R1+RN Reference test value, committed and measured
- R1+R2 Reference test value, committed and measured
- $(r1+r2)/4$ Calculated reference value,
- $(r1+rN)/4$ Calculated reference value.

5.6 Testing RCDs

Various test and measurements are required for verification of RCD(s) in RCD protected installations. Measurements are based on the EN 61557-6 standard.

The following measurements and tests (sub-functions) can be performed:

- Contact voltage,
- Trip-out time,
- Trip-out current,
- RCD autotest.

See chapter 4.1 *Function selection* for instructions on key functionality.

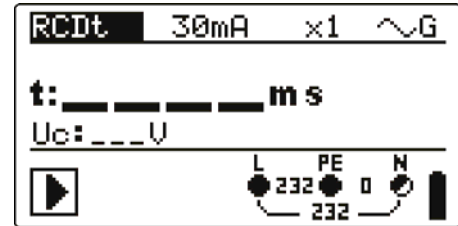

Figure 5.21: RCD test

Test parameters for RCD test and measurement

| | |
|----------------|---|
| TEST | RCD sub-function test [RCDt, RCD I, AUTO, Uc]. |
| $I_{\Delta N}$ | Rated RCD residual current sensitivity $I_{\Delta N}$ [10 mA, 30 mA, 100 mA, 300 mA, 500 mA, 1000 mA]. |
| type | RCD type AC, A, F, B, B+, starting polarity [\sim , \surd , \wedge , \vee , \oplus , \ominus], selective <input type="checkbox"/> or general <input type="checkbox"/> characteristic. |
| MUL | Multiplication factor for test current [$\frac{1}{2}$, 1, 2, 5 $I_{\Delta N}$]. |
| Ulim | Conventional touch voltage limit [25 V, 50 V]. |

Notes:

- Ulim can be selected in the Uc sub-function only.
- Selective (time delayed) RCDs have delayed response characteristics. As the contact voltage pre-test or other RCD tests influence the time delayed RCD it takes a certain period to recover into normal state. Therefore a time delay of 30 s is inserted before performing trip-out test by default.

Connections for testing RCD

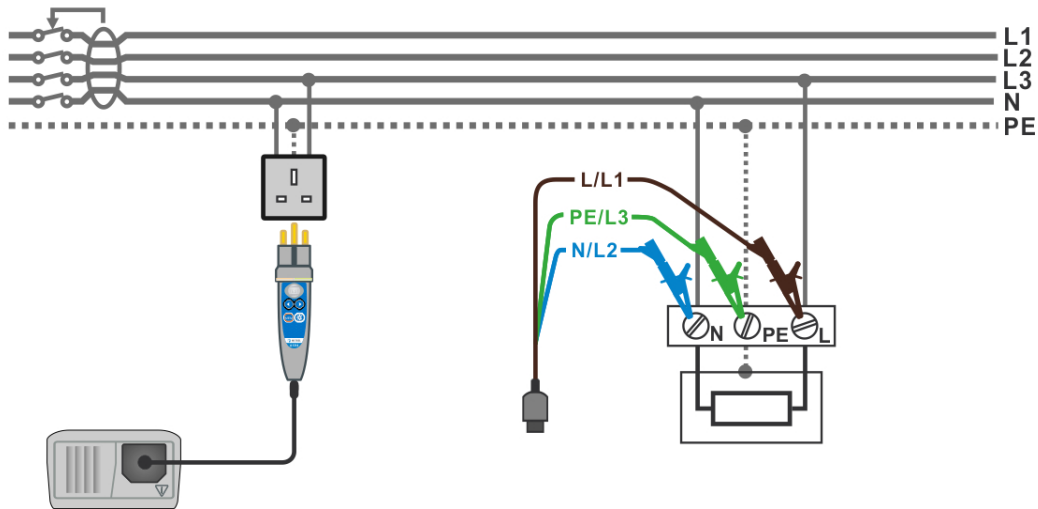

Figure 5.22: Connecting the plug cable or commander and the universal test cable

5.6.1 Contact voltage (RCD U_c)

A current flowing into the PE terminal causes a voltage drop on earth resistance, i.e. voltage difference between PE equipotential bonding circuit and earth. This voltage difference is called contact voltage and is present on all accessible conductive parts connected to the PE. It shall always be lower than the conventional safety limit voltage. The contact voltage is measured with a test current lower than $\frac{1}{2} I_{\Delta N}$ to avoid trip-out of the RCD and then normalized to the rated $I_{\Delta N}$.

Contact voltage measurement procedure

- ❑ Select the **RCD** function using the function selector switch.
- ❑ Set sub-function **U_c**.
- ❑ Set test **parameters** (if necessary).
- ❑ **Connect** test cable to the instrument.
- ❑ **Connect** test leads to the item to be tested (see figure 5.22).
- ❑ Press the **TEST** key to perform the measurement.
- ❑ **Store** the result by pressing the MEM key (optional).

The contact voltage result relates to the rated nominal residual current of the RCD and is multiplied by an appropriate factor (depending on RCD type and type of test current). The 1.05 factor is applied to avoid negative tolerance of result. See table 5.1 for detailed contact voltage calculation factors.

| RCD type | Contact voltage U_c proportional to | Rated $I_{\Delta N}$ |
|----------|---------------------------------------|----------------------|
| AC | <input type="checkbox"/> | any |
| AC | <input type="checkbox"/> S | |
| A, F | <input type="checkbox"/> | ≥ 30 mA |
| A, F | <input type="checkbox"/> S | |
| A, F | <input type="checkbox"/> | < 30 mA |
| A, F | <input type="checkbox"/> S | |

| | | | |
|-------|-------------------------------------|--|-----|
| B, B+ | <input type="checkbox"/> | $2 \times 1.05 \times I_{\Delta N}$ | any |
| B, B+ | <input checked="" type="checkbox"/> | $2 \times 2 \times 1.05 \times I_{\Delta N}$ | |

Table 5.1: Relationship between U_c and $I_{\Delta N}$

Loop resistance is indicative and calculated from U_c result (without additional proportional factors) according to: $R_L = \frac{U_c}{I_{\Delta N}}$.

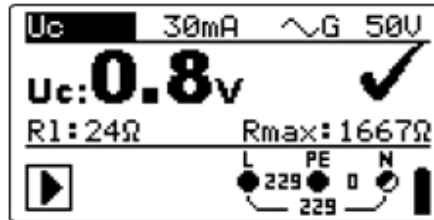

Figure 5.23: Example of contact voltage measurement results

Displayed results:

U_cContact voltage.

R_LFault loop resistance.

R_{max} ...Maximum earth fault loop resistance value according to BS 7671

5.6.2 Trip-out time (RCDt)

Trip-out time measurement verifies the sensitivity of the RCD at different residual currents.

Trip-out time measurement procedure

- Select the **RCD** function using the function selector switch.
- Set sub-function **RCDt**.
- Set test **parameters** (if necessary).
- Connect** test cable to the instrument.
- Connect** test leads to the item to be tested (see figure 5.22).
- Press the **TEST** key to perform the measurement.
- Store** the result by pressing the MEM key (optional).

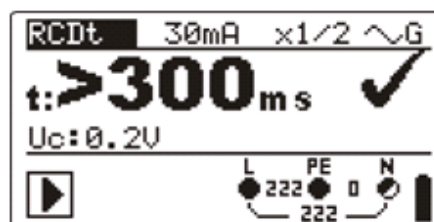

Figure 5.24: Example of trip-out time measurement results

Displayed results:

tTrip-out time,

U_cContact voltage for rated $I_{\Delta N}$.

5.6.3 Trip-out current (RCD I)

A continuously rising residual current is intended for testing the threshold sensitivity for RCD trip-out. The instrument increases the test current in small steps through appropriate range as follows:

| RCD type | Slope range | | Waveform |
|--|---------------------------|---------------------------|----------|
| | Start value | End value | |
| AC | $0.2 \times I_{\Delta N}$ | $1.1 \times I_{\Delta N}$ | Sine |
| A, F ($I_{\Delta N} \geq 30 \text{ mA}$) | $0.2 \times I_{\Delta N}$ | $1.5 \times I_{\Delta N}$ | Pulsed |
| A, F ($I_{\Delta N} = 10 \text{ mA}$) | $0.2 \times I_{\Delta N}$ | $2.2 \times I_{\Delta N}$ | |
| B, B+ | $0.2 \times I_{\Delta N}$ | $2.2 \times I_{\Delta N}$ | DC |

Maximum test current is I_{Δ} (trip-out current) or end value in case the RCD didn't trip-out.

Trip-out current measurement procedure

- ❑ Select the **RCD** function using the function selector switch.
- ❑ Set sub-function **RCD I**.
- ❑ Set test **parameters** (if necessary).
- ❑ **Connect** test cable to the instrument.
- ❑ **Connect** test leads to the item to be tested (see *figure 5.22*).
- ❑ Press the **TEST** key to perform the measurement.
- ❑ **Store** the result by pressing the MEM key (optional).

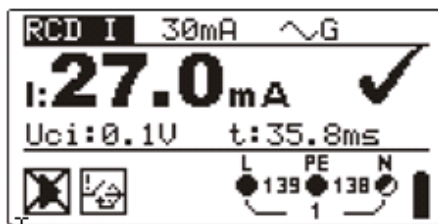

Trip-out

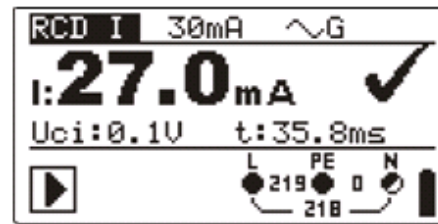

After the RCD is turned on again

Figure 5.25: Trip-out current measurement result example

Displayed results:

I Trip-out current,

Uci Contact voltage at trip-out current I or end value in case the RCD didn't trip,

t Trip-out time.

5.6.4 RCD Autotest

RCD autotest function is intended to perform a complete RCD test (trip-out time at different residual currents, trip-out current and contact voltage) in one set of automatic tests, guided by the instrument.

Additional key:

| | |
|-----------------------|---|
| HELP / DISPLAY | Toggles between top and bottom part of results field. |
|-----------------------|---|

RCD autotest procedure

| RCD Autotest steps | Notes |
|---|--|
| <ul style="list-style-type: none"> □ Select the RCD function using the function selector switch. □ Set sub-function AUTO. □ Set test parameters (if necessary). □ Connect test cable to the instrument. □ Connect test leads to the item to be tested (see <i>figure 5.22</i>). □ Press the TEST key to perform the test. | Start of test |
| <ul style="list-style-type: none"> □ Test with $I_{\Delta N}$, 0° (step 1). | RCD should trip-out |
| <ul style="list-style-type: none"> □ Re-activate RCD. □ Test with $I_{\Delta N}$, 180° (step 2). | RCD should trip-out |
| <ul style="list-style-type: none"> □ Re-activate RCD. □ Test with $5 \times I_{\Delta N}$, 0° (step 3). | RCD should trip-out |
| <ul style="list-style-type: none"> □ Re-activate RCD. □ Test with $5 \times I_{\Delta N}$, 180° (step 4). | RCD should trip-out |
| <ul style="list-style-type: none"> □ Re-activate RCD. □ Test with $\frac{1}{2} \times I_{\Delta N}$, 0° (step 5). □ Test with $\frac{1}{2} \times I_{\Delta N}$, 180° (step 6). | RCD should not trip-out RCD should not trip-out |
| <ul style="list-style-type: none"> □ Trip-out current test, 0° (step 7). | RCD should trip-out |
| <ul style="list-style-type: none"> □ Re-activate RCD. □ Trip-out current test, 180° (step 8). | RCD should trip-out |
| <ul style="list-style-type: none"> □ Re-activate RCD. □ Store the result by pressing the MEM key (optional). | End of test |

Result examples:

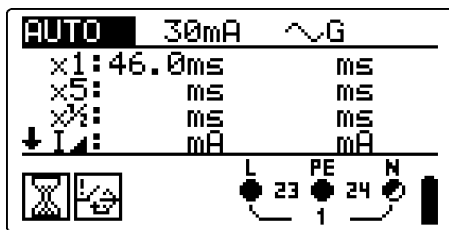

Step 1

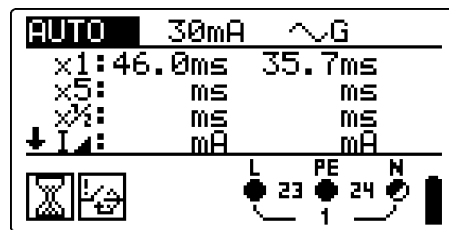

Step 2

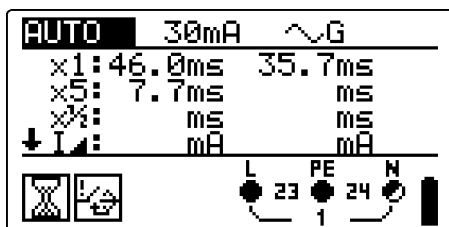

Step 3

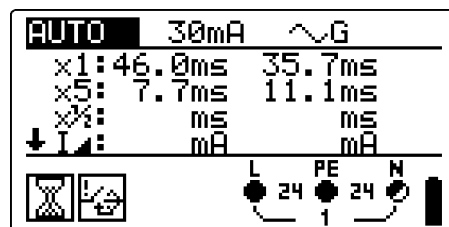

Step 4

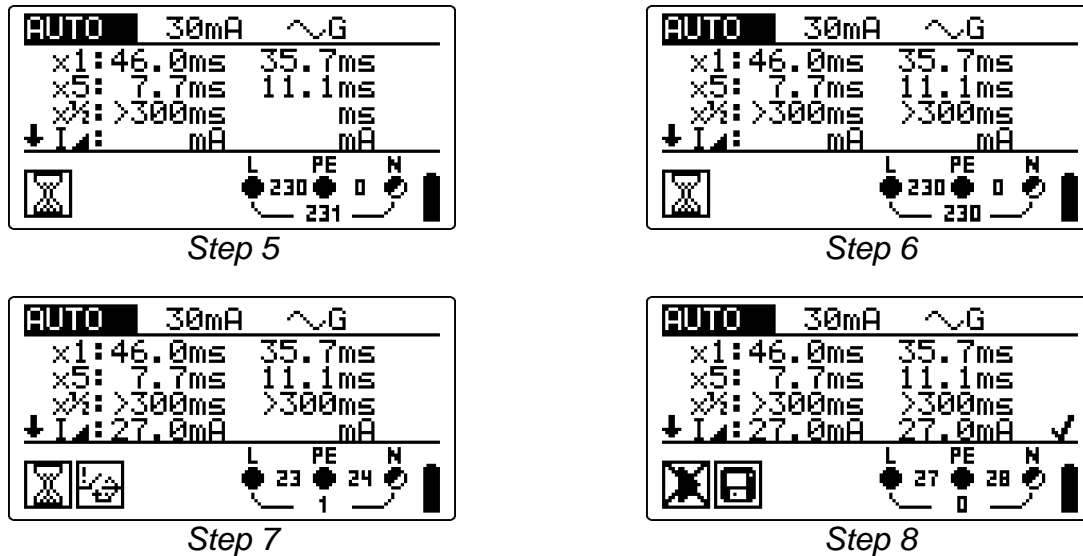

Figure 5.26: Individual steps in RCD autotest

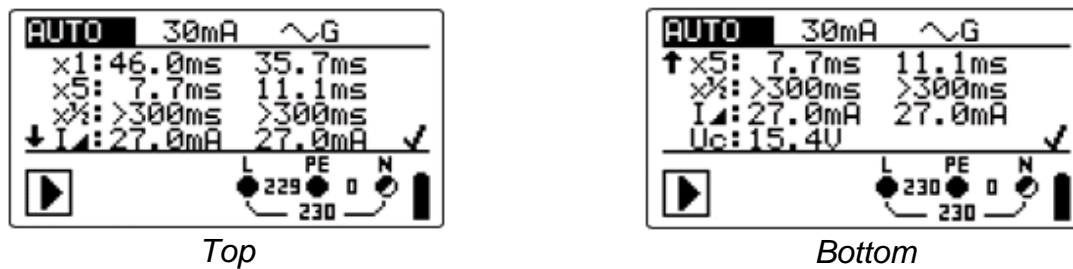

Figure 5.27: Two parts of result field in RCD autotest

Displayed results:

- x1 Step 1 trip-out time (t_{x1} , $I_{\Delta N}$, 0°),
- x1 Step 2 trip-out time (t_{x1} , $I_{\Delta N}$, 180°),
- x5 Step 3 trip-out time (t_{x5} , $5 \times I_{\Delta N}$, 0°),
- x5 Step 4 trip-out time (t_{x5} , $5 \times I_{\Delta N}$, 180°),
- $x_{1/2}$ Step 5 trip-out time ($t_{x_{1/2}}$, $\frac{1}{2} \times I_{\Delta N}$, 0°),
- $x_{1/2}$ Step 6 trip-out time ($t_{x_{1/2}}$, $\frac{1}{2} \times I_{\Delta N}$, 180°),
- I Step 7 trip-out current (0°),
- I Step 8 trip-out current (180°),
- Uc Contact voltage for rated $I_{\Delta N}$.

Notes:

- The autotest sequence is immediately stopped if any incorrect condition is detected, e.g. excessive U_c or trip-out time out of bounds.
- Auto test is finished without x5 tests in case of testing the RCD types A, F with rated residual currents of $I_{\Delta n} = 300 \text{ mA}$, 500 mA , and 1000 mA . In this case auto test result passes if all other results pass, and indications for x5 are omitted.
- Tests for sensitivity (I_{Δ} , steps 7 and 8) are omitted for selective type RCD.

5.7 Fault loop impedance and prospective fault current

Fault loop is a loop comprised by mains source, line wiring and PE return path to the mains source. The instrument measures the impedance of the loop and calculates the short circuit current. The measurement is covered by requirements of the EN 61557-3 standard.

See chapter 4.1 *Function selection* for instructions on key functionality.

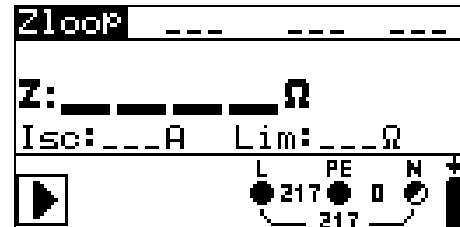

Figure 5.28: Fault loop impedance

Test parameters for fault loop impedance measurement

| | |
|-----------|--|
| Test | Selection of fault loop impedance sub-function [Zloop, Zs rcd] |
| Fuse type | Selection of fuse type [---, BS88-2, BS3036, BS88-3, BS1362, B, C, D] |
| Fuse I | Rated current of selected fuse |
| Fuse T | Maximum breaking time of selected fuse |
| Lim | Minimum short circuit current for selected fuse. |

See Appendix A for reference fuse data.

Circuits for measurement of fault loop impedance

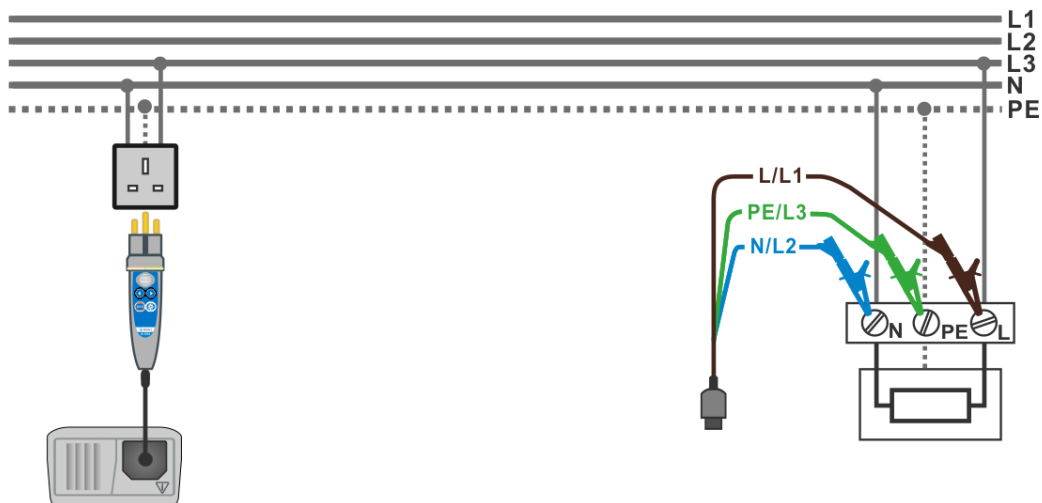

Figure 5.29: Connection of plug cable or commander and universal test cable

Fault loop impedance measurement procedure

- ❑ Select the **Zloop** or **Zs rcd** subfunction using the function selector switch and $\blacktriangle/\blacktriangledown$ keys.
- ❑ Select test **parameters** (optional).
- ❑ **Connect** test cable to the Eurotest Combo.
- ❑ **Connect** test leads to the item to be tested (see figures 5.29 and 5.22).
- ❑ Press the **TEST** key to perform the measurement.
- ❑ **Store** the result by pressing the MEM key (optional).



Figure 5.30: Examples of loop impedance measurement result

Displayed results:

- Z..... Fault loop impedance,
- Isc..... Prospective fault current,
- Lim High limit fault loop impedance value.

Prospective fault current I_{PFC} is calculated from measured impedance as follows:

$$I_{PFC} = \frac{U_N}{Z_{L-PE} \cdot scaling_factor}$$

where:

- Un Nominal U_{L-PE} voltage (see table below),
- Scaling factor..... Impedance correction factor (see chapter 4.2.5).

| U_n | Input voltage (L-PE) |
|-------|--|
| 110 V | $(93\text{ V} \leq U_{L-PE} < 134\text{ V})$ |
| 230 V | $(185\text{ V} \leq U_{L-PE} \leq 266\text{ V})$ |

Notes:

- ❑ High fluctuations of mains voltage can influence the measurement results (the noise sign  is displayed in the message field). In this case it is recommended to repeat few measurements to check if the readings are stable.
- ❑ The Zloop test will trip-out the RCD in RCD-protected electrical installation.
- ❑ Select Zs rcd to prevent trip-out of RCD in RCD protected installation.

5.8 Line impedance and prospective short-circuit current / Voltage drop

Line impedance is measured in loop comprising of mains voltage source and line wiring. Line impedance is covered by the requirements of the EN 61557-3 standard.

The Voltage drop sub-function is intended to check that a voltage in the installation stays above acceptable levels if the highest current is flowing in the circuit. The highest current is defined as the nominal current of the circuit's fuse. The limit values are described in the standard EN 60364-5-52.

Sub-functions:

- Z LINE- Line impedance measurement according to EN 61557-3,
- ΔU – Voltage drop measurement.

See chapter 4.1 *Function selection* for instructions on key functionality.

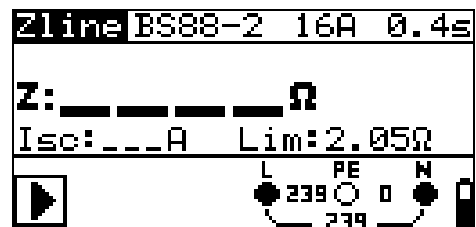

Figure 5.31: Line impedance

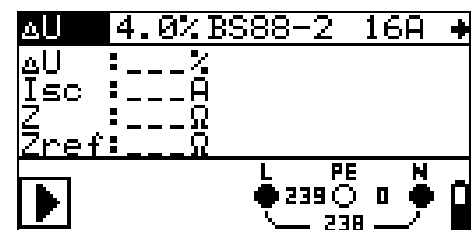

Figure 5.32: Voltage drop

Test parameters for line impedance measurement

| | |
|-----------|--|
| Test | Selection of line impedance [Zline] or voltage drop [ΔU] sub-function |
| FUSE type | Selection of fuse type [---, BS88-2, BS3036, BS88-3, BS1362, B, C, D] |
| FUSE I | Rated current of selected fuse |
| FUSE T | Maximum breaking time of selected fuse |
| Lim | Minimum short circuit current for selected fuse. |

See Appendix A for reference fuse data.

Additional test parameters for voltage drop measurement

| | |
|------------------|--|
| ΔU_{MAX} | Maximum voltage drop [3.0 % ÷ 9.0 %]. |
|------------------|--|

5.8.1 Line impedance and prospective short circuit current

Circuits for measurement of line impedance

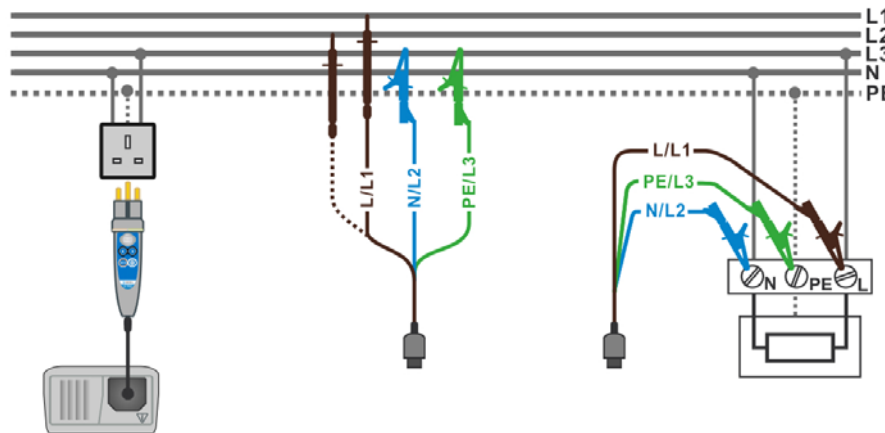

Figure 5.33: Phase-neutral or phase-phase line impedance measurement – connection of plug cable or commander and 3-wire test lead

Line impedance measurement procedure

- ❑ Select the **Z-LINE** sub-function.
- ❑ Select test **parameters** (optional).
- ❑ **Connect** test cable to the instrument.
- ❑ **Connect** test leads to the item to be tested (see figure 5.33).
- ❑ Press the **TEST** key to perform the measurement.
- ❑ **Store** the result by pressing the MEM key (optional).



Line to neutral



Line to line

Figure 5.34: Examples of line impedance measurement result

Displayed results:

Z.....Line impedance,

Isc.....Prospective short-circuit current,

LimLow limit prospective short-circuit current value or high limit line impedance value for the UK version.

Prospective short circuit current is calculated as follows:

$$I_{PSC} = \frac{U_N}{Z_{L-N(L)} \cdot scaling_factor}$$

where:

Un Nominal L-N or L1-L2 voltage (see table below),

Scaling factor Impedance correction factor (see chapter 4.2.5).

| U_n | Input voltage range (L-N or L1-L2) |
|-------|---|
| 110 V | $(93 \text{ V} \leq U_{L-N} < 134 \text{ V})$ |
| 230 V | $(185 \text{ V} \leq U_{L-N} \leq 266 \text{ V})$ |
| 400 V | $(321 \text{ V} < U_{L-L} \leq 485 \text{ V})$ |

Note:

- High fluctuations of mains voltage can influence the measurement results (the noise sign  is displayed in the message field). In this case it is recommended to repeat few measurements to check if the readings are stable.

5.8.2 Voltage drop

The voltage drop is calculated based on the difference of line impedance at connection points (sockets) and the line impedance at the reference point (usually the impedance at the switchboard).

Circuits for measurement for voltage drop

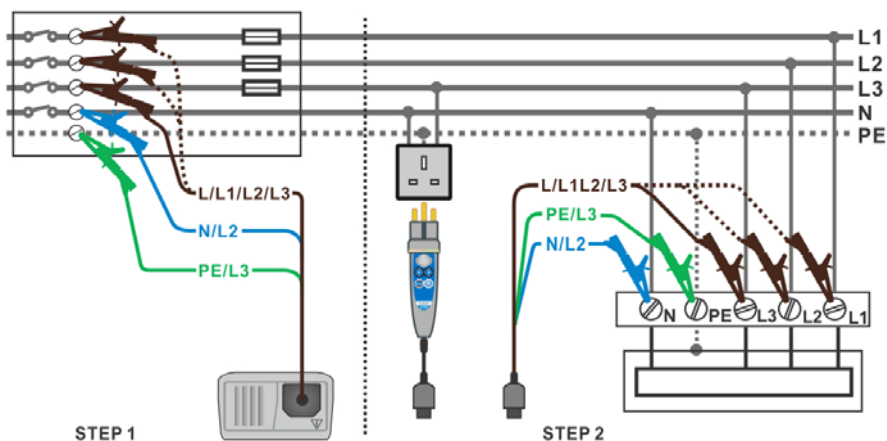

Figure 5.35: Phase-neutral or phase-phase voltage drop measurement – connection of plug cable or commander and 3-wire test lead

Voltage drop measurement procedure

Step 1: Measuring the impedance Z_{ref} at origin

- Select the **ΔU** sub-function using the function selector switch and $\blacktriangle/\blacktriangledown$ keys.
- Select test **parameters** (optional).
- **Connect** test cable to the instrument.
- **Connect** the test leads to the origin of electrical installation (see figure 5.35).
- Press the **CAL** key to perform the measurement.

Step 2: Measuring the voltage drop

- Select the **ΔU** sub-function using the function selector switch and $\blacktriangle/\blacktriangledown$ keys.
- Select test **parameters** (Fuse type must be selected).
- **Connect** test cable or plug commander to the instrument.
- **Connect** the test leads to the tested points (see figure 5.35).

- Press the **TEST** key to perform the measurement.
- **Store** the result by pressing the MEM key (optional).

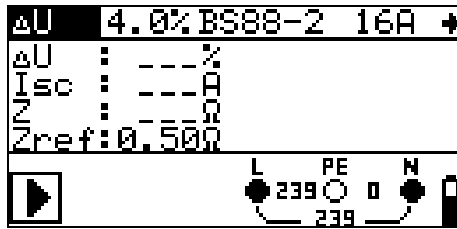

Step 1 - Zref

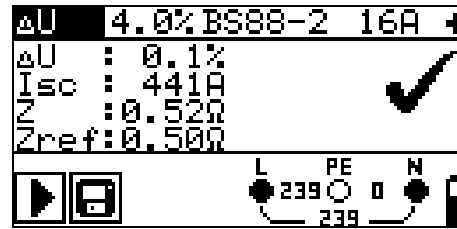

Step 2 - Voltage drop

Figure 5.36: Examples of voltage drop measurement result

Displayed results:

- ΔU Voltage drop,
- Isc Prospective short-circuit current,
- Z Line impedance at measured point,
- Zref Reference impedance

Voltage drop is calculated as follows:

$$\Delta U[\%] = \frac{(Z - Z_{REF}) \cdot I_N}{U_N} \cdot 100$$

where:

- ΔU calculated voltage drop
- Z impedance at test point
- Z_{REF} impedance at reference point
- I_N rated current of selected fuse
- U_N nominal voltage (see table below)

| U _n | Input voltage range (L-N or L1-L2) |
|----------------|------------------------------------|
| 110 V | (93 V ≤ U _{L-N} < 134 V) |
| 230 V | (185 V ≤ U _{L-N} ≤ 266 V) |
| 400 V | (321 V < U _{L-L} ≤ 485 V) |

Note:

- If the reference impedance is not set the value of Z_{REF} is considered as 0.00 Ω.
- The Z_{REF} is cleared (set to 0.00 Ω) if pressing CAL key while instrument is not connected to a voltage source.
- I_{SC} is calculated as described in chapter 5.8.1 Line impedance and prospective short circuit current.
- If the measured voltage is outside the ranges described in the table above the ΔU result will not be calculated.
- High fluctuations of mains voltage can influence the measurement results (the noise sign  is displayed in the message field). In this case it is recommended to repeat few measurements to check if the readings are stable.

5.9 Earth resistance

Earth resistance is one of the most important parameters for protection against electric shock. Main earthing arrangements, lightning systems, local earthings, etc can be verified with the earthing resistance test. The measurement conforms to the EN 61557-5 standard.

See chapter 4.1 *Function selection* for instructions on key functionality.



Figure 5.37: Earth resistance

Test parameters for earth resistance measurement

| | |
|-------|---|
| Limit | Maximum resistance OFF, 1 Ω ÷ 5 kΩ |
|-------|---|

Earth resistance measurements, common measurement procedure

- ❑ Select **EARTH** function using the function selector switch.
- ❑ Enable and set **limit** value (optional).
- ❑ **Connect** test leads to the instrument
- ❑ **Connect** the item to be tested (see figures 5.38, 5.39).
- ❑ Press the **TEST** key to perform the measurement.
- ❑ **Store** the result by pressing the MEM key (optional).

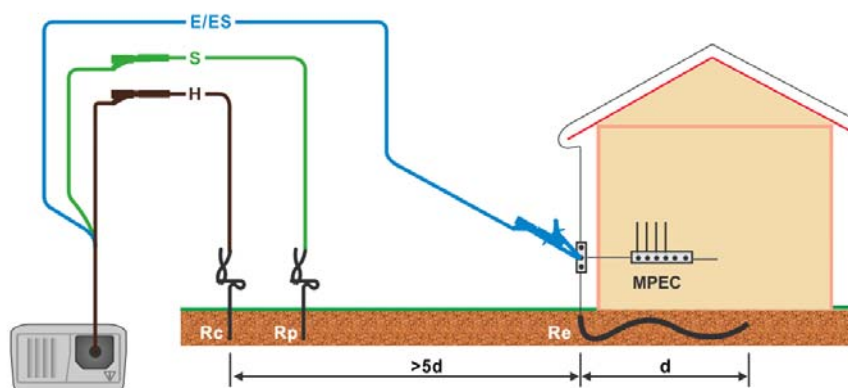

Figure 5.38: Resistance to earth, measurement of main installation earthing

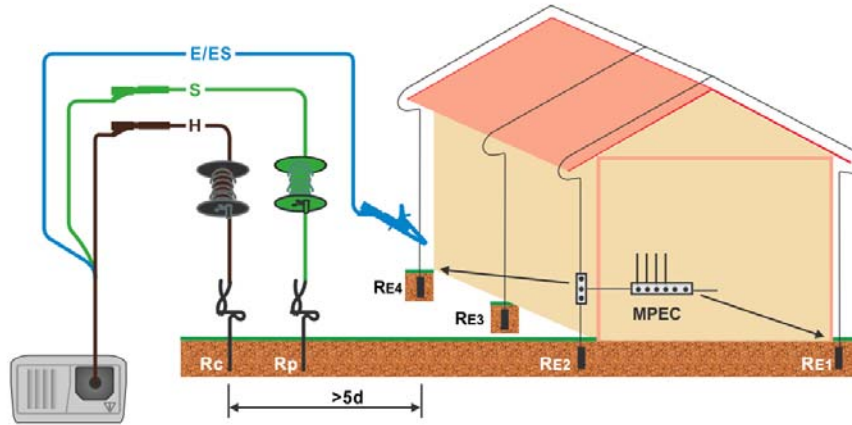

Figure 5.39: Resistance to earth, measurement of a lighting protection system

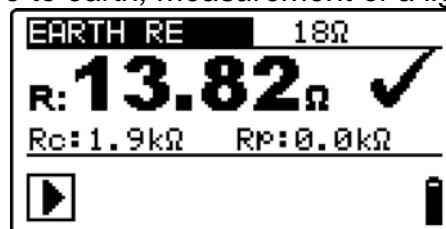

Figure 5.40: Example of earth resistance measurement result

Displayed results for earth resistance measurement:

R..... Earth resistance,
 Rp..... Resistance of S (potential) probe,
 Rc..... Resistance of H (current) probe.

Notes:

- High resistance of S and H probes could influence the measurement results. In this case, “Rp” and “Rc” warnings are displayed. There is no pass / fail indication in this case.
- High noise currents and voltages in earth could influence the measurement results. The tester displays the “noise” warning in this case.
- Probes must be placed at sufficient distance from the measured object.

5.10 PE test terminal

It can happen that a dangerous voltage is applied to the PE wire or other accessible metal parts. This is a very dangerous situation since the PE wire and MPEs are considered to be earthed. An often reason for this fault is incorrect wiring (see examples below).

When touching the **TEST** key in all functions that require mains supply the user automatically performs this test.

Examples for application of PE test terminal

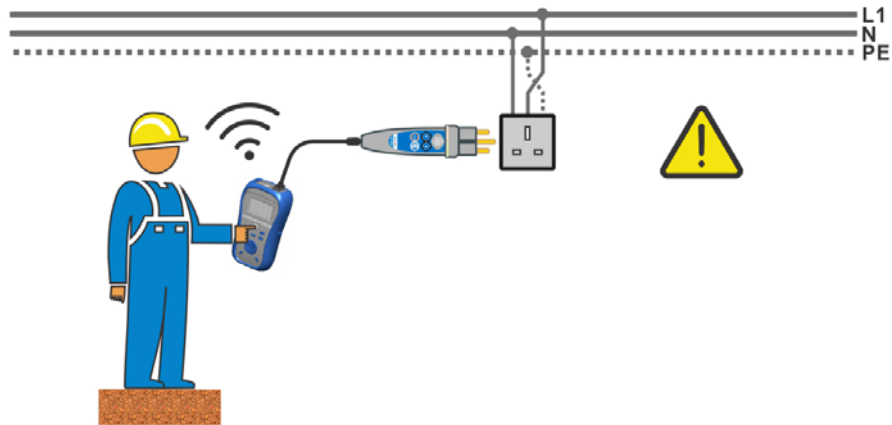

Figure 5.41: Reversed L and PE conductors (application of plug cable or commander)

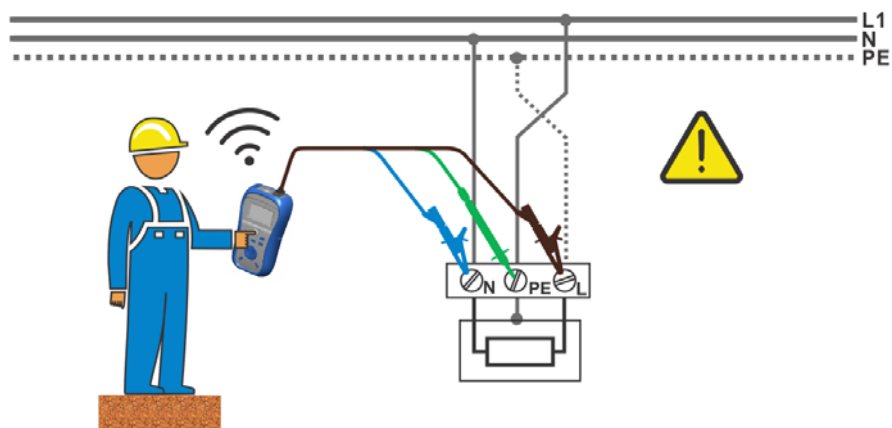

Figure 5.42: Reversed L and PE conductors (application of universal test cable)



Reversed phase and protection conductors! The most dangerous situation!

PE terminal test procedure

- ❑ **Connect** test cable to the instrument.
- ❑ **Connect** test leads to the item to be tested (see figures 5.41 and 5.42).
- ❑ Touch PE test probe (the **TEST** key) for at least one second.
- ❑ If PE terminal is connected to phase voltage the warning message is displayed, instrument buzzer is activated, and further measurements are disabled in Z-LOOP and RCD functions.

Warning:

- ❑ If dangerous voltage is detected on the tested PE terminal, immediately stop all measurements, find and remove the fault!

Notes:

- ❑ In the SETTINGS and VOLTAGE TRMS menus the PE terminal is not tested.
- ❑ PE test terminal does not operate in case the operator's body is completely insulated from floor or walls!

6 Data handling

6.1 Memory organization

Measurement results together with all relevant parameters can be stored in the instrument's memory. After the measurement is completed, results can be stored to the flash memory of the instrument, together with the sub-results and function parameters.

6.2 Data structure

The instrument's memory place is organized in a four-level structure as follows:

- Object (1st structure level, the highest level),
- Distribution Board (2nd structure level),
- Circuit, Earth Electrode, Bonding conductors (3rd structure level),
- Connection (4th structure level).

```

OBJECT 001
  > DISTRIBUTION BOARD 001
    > CIRCUIT 001
    > CIRCUIT 002
    ...
    > CIRCUIT 199
  > EARTH ELECTRODE
  > BONDING Water
  > BONDING Oil
  > BONDING Lightning
  > BONDING Gas
  > BONDING Structural Steel
  > BONDING Other
  > BONDING Earthing conductor
    > CONNECTION 001
    ...
    > CONNECTION 199
  > DISTRIBUTION BOARD 002
    > CIRCUIT 001
    > CIRCUIT 002
    ...
    > CIRCUIT 199
  > EARTH ELECTRODE
  > BONDING Water
  > BONDING Oil
  > BONDING Lightning
  > BONDING Gas
  > BONDING Structural Steel
  > BONDING Other
  > BONDING Earthing conductor
    > CONNECTION 001
    ...
    > CONNECTION 199
  > DISTRIBUTION BOARD 199
    > CIRCUIT 001
    > CIRCUIT 002
    ...
    > CIRCUIT 199
  > EARTH ELECTRODE
  > BONDING Water
  > BONDING Oil
  > BONDING Lightning
  > BONDING Gas

```

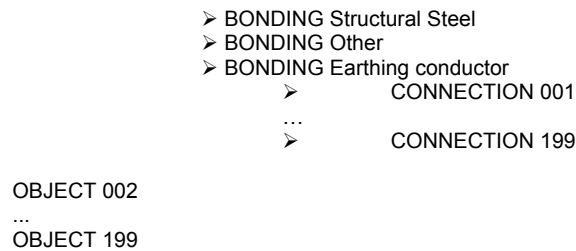

Figure 6.1: Instrument memory organization

The memory structure is organized in a way that is suited to BS 7671 and other verification documents (Electrical Installation Certificate, Periodic Inspection Report etc.). If the results are stored in appropriate memory locations an automatic creation of a certificate/ report is possible.

Display organization

The **installation structure field** describes the location of the measurement (which object, board, circuit, connection).

In the **measurement field** there is information about type and number of measurements that belong to the selected structure element (object and board and circuit and connection).

The main advantages of this system are:

- Test results can be organized and grouped in a structured manner that reflects the structure of the electrical installation.
- Customized names of data structure elements can be uploaded from EurolinkPRO PCSW.
- Simple browsing through the structure and results.
- Test certificates / reports can be created with no or little modifications after downloading results to a PC.

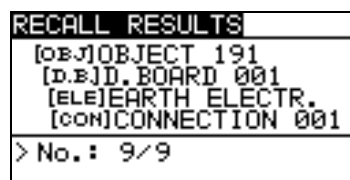

Figure 6.2: Installation structure and measurement fields

Installation structure elements

| RECALL RESULTS | Memory operation menu |
|--|--|
| [OBJ]OBJECT 002 [D.B.]D. BOARD 002 [CIR]CIRCUIT 009 [CON]CONNECTION 003 | Data structure field |
| [OBJ]OBJECT 002 | <ul style="list-style-type: none"> □ 1st level: OBJECT: Default location name (object and its successive number). |
| [D.B.]D. BOARD 002 | <ul style="list-style-type: none"> □ 2nd level: D.BOARD: Default location name (distribution board and its successive number). |
| [CIR]CIRCUIT 009 | <ul style="list-style-type: none"> □ 3rd level: |

| | |
|---|---|
| [B.O.]BONDING OIL [ELE]EARTH ELECTR. | CIRCUIT: Default location name (circuit and its successive number). BONDING xxx: Default location names (7 bonding connections). EARTH ELECTR.: Default location name (earth electrode). |
| [CON]CONNECTION 003 | □ 4th level: CONNECTION: Default location name (connection and its successive number). 003: No. of selected element. |
| No.: 20 [112] | No. of measurements in selected location [No. of measurements in selected location and its sub-locations] |
| Measurement field | |
| No.: 37/72 | No. of selected test result / No. of all stored test results in selected location. |
| R ISO | Type of stored measurement in the selected location. |

6.3 Storing test results

After the completion of a test the results and parameters are ready for storing (📁 icon is displayed in the information field). By pressing the **MEM** key, the user can store the results.

```

RECALL RESULTS
[O.B.]OBJECT 191
[D.B.]D. BOARD 001
[ELE]EARTH ELECTR.
> [CON]CONNECTION 001
FREE: 99.7%
MEM : SAVE

```

Figure 6.3: Save test menu

FREE:
92.5% Memory space available for storing results.

Keys in save test menu - installation structure field:

| | |
|---------------------------------|--|
| TAB | Selects the location element (Object / D. Board / Circuit or Bonding or Electrode/ Connection) |
| UP / DOWN | Selects the location element in selected level. |
| MEM | Saves test results to the selected location and returns to the measuring menu. |
| Function selector / TEST | Exits back to main function menu. |

Notes:

- The instrument offers to store the result to the last selected location by default.
- If the measurement is to be stored to the same location as the previous one just press the **MEM** key twice.

6.4 Recalling test results

Press the **MEM** key in a main function menu when there is no result available for storing or select **MEMORY** in the **SETTINGS** menu.

| RECALL RESULTS |
|---|
| [OBJ]OBJECT 191 [D.B.]D. BOARD 001 > [ELE]EARTH ELECTR. [CON]----- |
| No.: 0 [4] |

Figure 6.4: Recall menu - installation structure field selected

| RECALL RESULTS |
|--|
| [OBJ]OBJECT 191 [D.B.]D. BOARD 001 [ELE]EARTH ELECTR. [CON]CONNECTION 001 |
| > No.: 1/4 VOLTAGE TRMS |

Figure 6.5: Recall menu - measurements field selected

Keys in recall memory menu (installation structure field):

| | |
|---------------------------------|--|
| TAB | Selects the location element (Object / D. Board / Circuit or Bonding or Electrode / Connection). |
| UP / DOWN | Selects the location element in selected level. |
| Function selector / TEST | Exits back to main function menu. |
| MEM | Enters measurements field. |

Keys in recall memory menu (measurements field):

| | |
|---------------------------------|--|
| UP / DOWN | Selects the stored measurement. |
| TAB | Returns to installation structure field. |
| Function selector / TEST | Exits back to main function menu. |
| MEM | View selected measurement results. |

| |
|-------------------------|
| Zline --- --- --- |
| z: 4.27 Ω |
| Isc: 53.9A Lim: ---A |
| > 6/6 MEM |

Figure 6.6: Example of recalled measurement result

Keys in recall memory menu (measurement results are displayed)

| | |
|---------------------------------|---|
| UP / DOWN | Displays measurement results stored in selected location. |
| MEM | Returns to measurements field. |
| Function selector / TEST | Exits back to main function menu. |

6.5 Clearing stored data

6.5.1 Clearing complete memory content

Select **CLEAR ALL MEMORY** in **MEMORY** menu. A warning (see Figure 6.7) will be displayed.

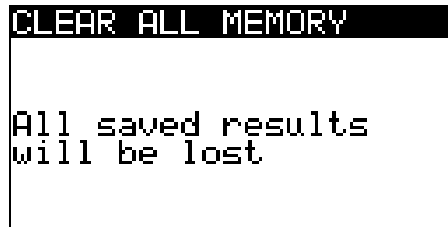

Figure 6.7: Clear all memory

Keys in clear all memory menu:

| | |
|--------------------------|---|
| TEST | Confirms clearing of complete memory content. |
| Function selector | Exits back to main function menu without changes. |

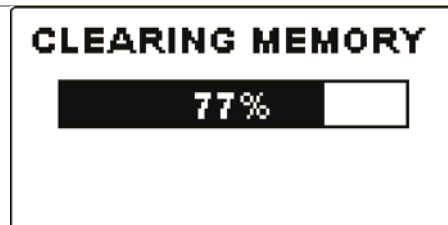

Figure 6.8: Clearing memory in progress

6.5.2 Clearing measurement(s) in selected location and its sub-locations

Select **DELETE RESULTS** in **MEMORY** menu.

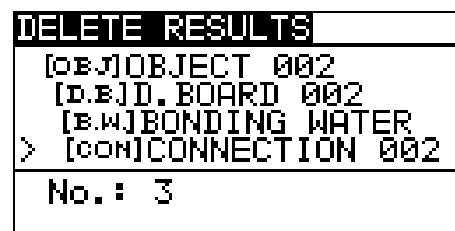
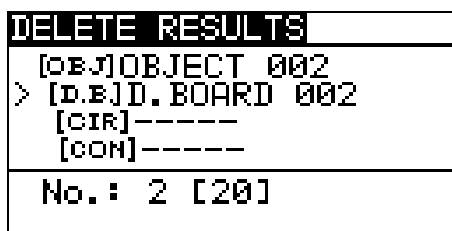

Figure 6.9: Clear measurements menu (data structure field selected)

Keys in delete results menu (installation structure field selected):

| | |
|---------------------------------|--|
| TAB | Selects the location element (Object / D. Board / Circuit or Bonding or Electrode / Connection). |
| UP / DOWN | Selects the location element in selected level. |
| Function selector / TEST | Exits back to main function menu. |
| HELP | Enters dialog box for deleting all measurements in selected location and its sub-locations. |

Keys in dialog box for clearing results in selected location and its sub-locations:

| | |
|---------------------------------|--|
| HELP | Deletes all results in selected location/ sub-location(s) |
| TAB / MEM | Exits back to installation structure field menu without changes. |
| Function selector / TEST | Exits back to main function menu without changes. |

6.5.3 Clearing individual measurements

Select **DELETE RESULTS** in **MEMORY** menu.

| |
|---|
| DELETE RESULTS |
| [obj]OBJECT 002 [d.b]D. BOARD 002 [cir]CIRCUIT 001 [con]CONNECTION 001 |
| > No. : 2/2 ISO L/E |

Figure 6.10: Menu for clearing individual measurement (installation structure field selected)

Keys in delete results menu (installation structure field selected):

| | |
|---------------------------------|---|
| TAB | Selects the location element (Object / D. Board / Circuit or Bonding or Electrode/ Connection). |
| UP / DOWN | Selects the location element in selected level. |
| Function selector / TEST | Exits back to main function menu. |
| MEM | Enters measurements field. |

Keys in delete results menu (measurements field selected):

| | |
|---------------------------------|--|
| UP / DOWN | Selects measurement. |
| HELP | Opens dialog box for confirmation to clear selected measurement. |
| TAB | Returns to installation structure field. |
| Function selector / TEST | Exits back to main function menu without changes. |

Keys in dialog for confirmation to clear selected result(s):

| | |
|---------------------------------|---|
| HELP | Deletes selected measurement result. |
| MEM / TAB | Exits back to measurements field without changes. |
| Function selector / TEST | Exits back to main function menu without changes. |

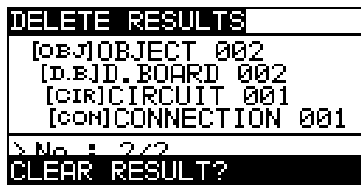

Figure 6.11: Dialog for confirmation

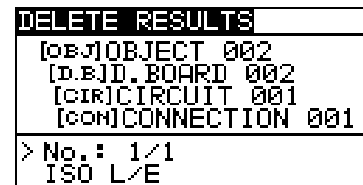

Figure 6.12: Display after measurement was cleared

6.5.4 Renaming installation structure elements (upload from PC)

Default installation structure elements are 'Object', 'D.Board', 'Earth Electr.' and 'Connection'. In the PCSW package EurolinkPRO default names can be changed with customized names that corresponds the installation under test. Refer to PCSW EurolinkPRO HELP for information how to upload customized installation names to the instrument.

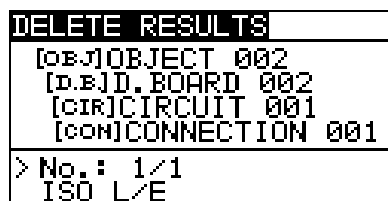

Figure 6.13: Example of menu with customized installation structure names

6.5.5 Renaming installation structure elements with serial barcode reader or RFID reader

Default installation structure elements are 'Object', 'D.Board', 'Earth Electr.' and 'Connection'. When the instrument is in the Save results menu location ID can be scanned from a barcode label with the barcode reader or can be read from a RFID tag with the RFID reader.

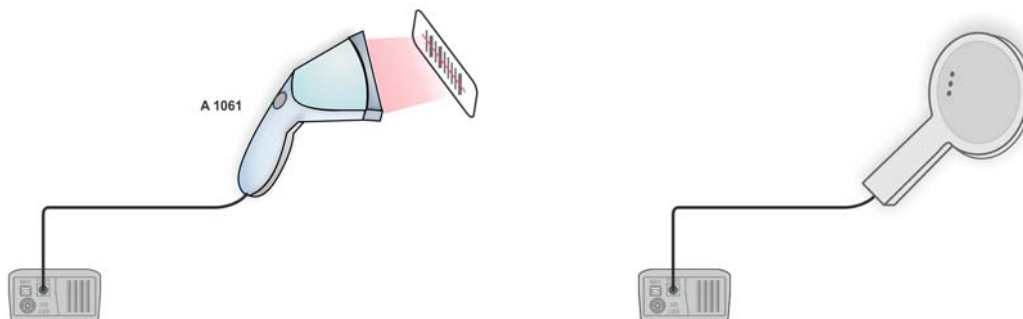

Figure 6.14: Connection of the barcode reader and RFID reader

How to change the name of memory location

- ❑ Connect the barcode reader or RFID reader to the instrument.
- ❑ In Save menu select memory location to be renamed.
- ❑ A new location name (scanned from a barcode label or a RFID tag) will be accepted by the instrument. A successful receive of a barcode or RFID tag is confirmed by two short confirmation beeps.

Note:

- ❑ Use only barcode readers and RFID readers delivered by Metrel or authorized distributor.

6.6 Communication

Stored results can be transferred to a PC. A special communication program on the PC automatically identifies the instrument and enables data transfer between the instrument and the PC.

There are three communication interfaces available: USB, RS 232 and Bluetooth.

6.6.1 USB and RS232 communication

The instrument automatically selects the communication mode according to detected interface. USB interface has priority.

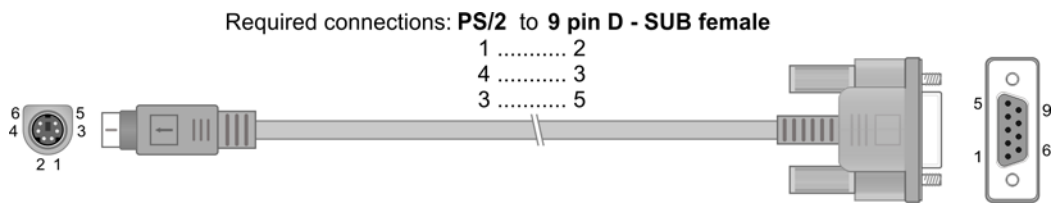

Figure 6.15: Interface connection for data transfer over PC COM port

How to establish an USB or RS232 link:

- ❑ RS-232 communication: connect a PC COM port to the instrument PS/2 connector using the PS/2 - RS232 serial communication cable;
- ❑ USB communication: connect a PC USB port to the instrument USB connector using the USB interface cable.
- ❑ Switch **on** the PC and the instrument.
- ❑ **Run** the *EuroLinkPRO* program.
- ❑ The PC and the instrument will automatically recognize each other.
- ❑ The instrument is prepared to communicate with the PC.

The program *EuroLinkPRO* is a PC software running on Windows XP, Windows Vista, Windows 7, and Windows 8. Read the file README_EuroLink.txt on CD for instructions about installing and running the program.

Note:

- ❑ USB drivers should be installed on PC before using the USB interface. Refer to USB installation instructions available on installation CD.

6.6.2 Bluetooth communication

The internal Bluetooth module enables easy communication via Bluetooth with PC and Android devices.

How to configure a Bluetooth link between instrument and PC

- ❑ Switch On the instrument.
- ❑ On PC configure a Standard Serial Port to enable communication over Bluetooth link between instrument and PC. No code for pairing the devices is needed.
- ❑ Run the *EurolinkPRO* program.
- ❑ The PC and the instrument will automatically recognize each other.
- ❑ The instrument is prepared to communicate with the PC.

How to configure a Bluetooth link between instrument and Android device

- ❑ Switch On the instrument.
- ❑ Some Android applications automatically carry out the setup of a Bluetooth connection. It is preferred to use this option if it exists.
This option is supported by Metrel's Android applications.
- ❑ If this option is not supported by the selected Android application then configure a Bluetooth link via Android device's Bluetooth configuration tool. No code for pairing the devices is needed.
- ❑ The instrument and Android device are ready to communicate.

Notes:

- ❑ Sometimes there will be a demand from the PC or Android device to enter the code. Enter code 'NNNN' to correctly configure the Bluetooth link.
- ❑ The name of correctly configured Bluetooth device must consist of the instrument type plus serial number, eg. *MI 3125 BT-12240429I*. If the Bluetooth module got another name, the configuration must be repeated.
- ❑ In case of serious troubles with the Bluetooth communication it is possible to reinitialize the internal Bluetooth module. The initialization is carried out during the Initial settings procedure. In case of a successful initialization "INTERNAL BLUETOOTH SEARCHING OK!" is displayed at the end of the procedure. See chapter 4.2.7 *Initial settings*.

7 Maintenance

Unauthorized persons are not allowed to open the Eurotest Combo instrument. There are no user replaceable components inside the instrument, except the battery and fuse under rear cover.

7.1 Fuse replacement

There is a fuse under back cover of the Eurotest Combo instrument.

- F1
M 0.315 A / 250 V, 20×5 mm
This fuse protects internal circuitry for continuity functions if test probes are connected to the mains supply voltage by mistake during measurement.

Warnings:

-  **Disconnect all measuring accessory and switch off the instrument before opening battery / fuse compartment cover, hazardous voltage inside!**
- Replace blown fuse with original type only, otherwise the instrument may be damaged and/or operator's safety impaired!

Position of fuses can be seen in *Figure 3.4* in *chapter 3.3 Back side*.

7.2 Cleaning

No special maintenance is required for the housing. To clean the surface of the instrument use a soft cloth slightly moistened with soapy water or alcohol. Then leave the instrument to dry totally before use.

Warnings:

- Do not use liquids based on petrol or hydrocarbons!
- Do not spill cleaning liquid over the instrument!

7.3 Periodic calibration

It is essential that the test instrument is regularly calibrated in order that the technical specification listed in this manual is guaranteed. We recommend an annual calibration. Only an authorized technical person can do the calibration. Please contact your dealer for further information.

7.4 Upgrading the instrument

The instrument can be upgraded from a PC via the RS232 communication port. This enables to upgrade the instrument to the latest available software version. The upgrade can be carried with a help of special upgrading software and the communication cable as shown on

Figure 6.15. Please contact your dealer for more information.

7.5 Service

For repairs under warranty, or at any other time, please contact your distributor.

8 Technical specifications

8.1 Insulation resistance (ISO L/N, ISO L/E, ISO N/E, ISO L/L)

Insulation resistance (nominal voltages 50 V_{DC}, 100 V_{DC} and 250 V_{DC})

Measuring range according to EN61557 is 0.25 M Ω ÷ 199.9 M Ω .

| Measuring range (M Ω) | Resolution (M Ω) | Accuracy |
|-------------------------------|--------------------------|------------------------------|
| 0.00 ÷ 19.99 | 0.01 | ±(5 % of reading + 3 digits) |
| 20.0 ÷ 99.9 | 0.1 | ±(10 % of reading) |
| 100.0 ÷ 199.9 | | ±(20 % of reading) |

Insulation resistance (nominal voltages 500 V_{DC} and 1000 V_{DC})

Measuring range according to EN61557 is 0.15 M Ω ÷ 1 G Ω .

| Measuring range (Ω) | Resolution (M Ω) | Accuracy |
|------------------------------|--------------------------|------------------------------|
| 0.00M ÷ 19.99M | 0.01 | ±(5 % of reading + 3 digits) |
| 20.0M ÷ 199.9M | 0.1 | ±(5 % of reading) |
| 200M ÷ 999M | 1 | ±(10 % of reading) |

Voltage

| Measuring range (V) | Resolution (V) | Accuracy |
|---------------------|----------------|------------------------------|
| 0 ÷ 1200 | 1 | ±(3 % of reading + 3 digits) |

Nominal voltages50 V_{DC}, 100 V_{DC}, 250 V_{DC}, 500 V_{DC}, 1000 V_{DC}

Open circuit voltage-0 % / +20 % of nominal voltage

Measuring current.....min. 1 mA at R_N=U_N×1 k Ω /V

Short circuit current..... max. 3 mA

The number of possible tests..... > 1200, with a fully charged battery

Auto discharge after test.

Specified accuracy is valid up to 100 M Ω if relative humidity > 85 %.

In case the instrument gets moistened, the results could be impaired. In such case, it is recommended to dry the instrument and accessories for at least 24 hours.

The error in operating conditions could be at most the error for reference conditions (specified in the manual for each function) ±5 % of measured value.

8.2 Continuity & Ring (r₁, r₂, r_N, R₁+R₂, R₁+R_N)

Measuring range according to EN61557 is 0.16 Ω ÷ 1999 Ω .

| Measuring range R (Ω) | Resolution (Ω) | Accuracy |
|--------------------------------|-------------------------|------------------------------|
| 0.00 ÷ 19.99 | 0.01 | ±(3 % of reading + 3 digits) |
| 20.0 ÷ 199.9 | 0.1 | ±(5 % of reading) |
| 200 ÷ 999 | 1 | |
| 1000 ÷ 1999 | 1 | ±(10 % of reading) |

Open-circuit voltage6.5 VDC ÷ 9 VDC

Measuring current.....min. 200 mA into load resistance of 2 Ω

Test lead compensation.....up to 5 Ω

The number of possible tests> 2000, with a fully charged battery

Automatic polarity reversal of the test voltage.

8.3 RCD testing

8.3.1 General data

Nominal residual current (A, F, AC) ... 10 mA, 30 mA, 100 mA, 300 mA, 500 mA, 1000 mA
 Nominal residual current accuracy -0 / +0.1·I_Δ; I_Δ = I_{ΔN}, 2×I_{ΔN}, 5×I_{ΔN}
 -0.1·I_Δ / +0; I_Δ = 0.5×I_{ΔN}
 AS / NZ selected: ± 5 %
 Test current shape Sine-wave (AC), pulsed (A, F), smooth DC (B, B+)
 DC offset for pulsed test current 6 mA (typical)
 RCD type (non-delayed), S (time-delayed)
 Test current starting polarity 0 ° or 180 °
 Voltage range 93 V ÷ 134 V (45 Hz ÷ 65 Hz)
 185 V ÷ 266 V (45 Hz ÷ 65 Hz)

| I _{ΔN} (mA) | I _{ΔN} × 1/2 | | | I _{ΔN} × 1 | | | I _{ΔN} × 2 | | | I _{ΔN} × 5 | | | RCD I _Δ | | |
|----------------------|-----------------------|------|------|---------------------|------|------|---------------------|------|------|---------------------|------|------|--------------------|-----|------|
| | AC | A,F | B,B+ | AC | A,F | B,B+ | AC | A,F | B,B+ | AC | A,F | B,B+ | AC | A,F | B,B+ |
| 10 | 5 | 3.5 | 5 | 10 | 20 | 20 | 20 | 40 | 40 | 50 | 100 | 100 | ✓ | ✓ | ✓ |
| 30 | 15 | 10.5 | 15 | 30 | 42 | 60 | 60 | 84 | 120 | 150 | 212 | 300 | ✓ | ✓ | ✓ |
| 100 | 50 | 35 | 50 | 100 | 141 | 200 | 200 | 282 | 400 | 500 | 707 | 1000 | ✓ | ✓ | ✓ |
| 300 | 150 | 105 | 150 | 300 | 424 | 600 | 600 | 848 | n.a. | 1500 | n.a. | n.a. | ✓ | ✓ | ✓ |
| 500 | 250 | 175 | 250 | 500 | 707 | 1000 | 1000 | 1410 | n.a. | 2500 | n.a. | n.a. | ✓ | ✓ | ✓ |
| 1000 | 500 | 350 | 500 | 1000 | 1410 | n.a. | 2000 | n.a. | n.a. | n.a. | n.a. | n.a. | ✓ | ✓ | n.a. |

n.a.....not applicable
 AC type sine wave test current
 A, F types pulsed current
 B, B+ types smooth DC current

8.3.2 Contact voltage RCD-Uc

Measuring range according to EN61557 is 20.0 V ÷ 31.0V for limit contact voltage 25V
 Measuring range according to EN61557 is 20.0 V ÷ 62.0V for limit contact voltage 50V

| Measuring range (V) | Resolution (V) | Accuracy |
|---------------------|----------------|---------------------------------------|
| 0.0 ÷ 19.9 | 0.1 | (-0 % / +15 %) of reading ± 10 digits |
| 20.0 ÷ 99.9 | | (-0 % / +15 %) of reading |

The accuracy is valid if mains voltage is stable during the measurement and PE terminal is free of interfering voltages.

Test current max. 0.5×I_{ΔN}
 Limit contact voltage 25 V, 50 V
 Specified accuracy is valid for complete operating range.

8.3.3 Trip-out time

Complete measurement range corresponds to EN 61557 requirements.
 Maximum measuring times set according to selected reference for RCD testing.

| Measuring range (ms) | Resolution (ms) | Accuracy |
|----------------------|-----------------|----------|
| 0.0 ÷ 40.0 | 0.1 | ±1 ms |

| | | |
|-------------------|-----|-------|
| 0.0 ÷ max. time * | 0.1 | ±3 ms |
|-------------------|-----|-------|

* For max. time see normative references in 4.2.3 – this specification applies to max. time >40 ms.

Test current $\frac{1}{2} \times I_{\Delta N}$, $I_{\Delta N}$, $2 \times I_{\Delta N}$, $5 \times I_{\Delta N}$

$5 \times I_{\Delta N}$ is not available for $I_{\Delta N}=1000$ mA (RCD type AC) or $I_{\Delta N} \geq 300$ mA (RCD types A, F, B, B+).

$2 \times I_{\Delta N}$ is not available for $I_{\Delta N}=1000$ mA (RCD types A, F) or $I_{\Delta N} \geq 300$ mA (RCD types B, B+).

$1 \times I_{\Delta N}$ is not available for $I_{\Delta N}=1000$ mA (RCD types B, B+).

Specified accuracy is valid for complete operating range.

8.3.4 Trip-out current

Trip-out current

Complete measurement range corresponds to EN 61557 requirements.

| Measuring range I_{Δ} | Resolution I_{Δ} | Accuracy |
|---|----------------------------|-------------------------------|
| $0.2 \times I_{\Delta N} \div 1.1 \times I_{\Delta N}$ (AC type) | $0.05 \times I_{\Delta N}$ | $\pm 0.1 \times I_{\Delta N}$ |
| $0.2 \times I_{\Delta N} \div 1.5 \times I_{\Delta N}$ (A, F type, $I_{\Delta N} \geq 30$ mA) | $0.05 \times I_{\Delta N}$ | $\pm 0.1 \times I_{\Delta N}$ |
| $0.2 \times I_{\Delta N} \div 2.2 \times I_{\Delta N}$ (A, F type, $I_{\Delta N} < 30$ mA) | $0.05 \times I_{\Delta N}$ | $\pm 0.1 \times I_{\Delta N}$ |
| $0.2 \times I_{\Delta N} \div 2.2 \times I_{\Delta N}$ (B, B+ types)* | $0.05 \times I_{\Delta N}$ | $\pm 0.1 \times I_{\Delta N}$ |

Trip-out time

| Measuring range (ms) | Resolution (ms) | Accuracy |
|----------------------|-----------------|----------|
| 0 ÷ 300 | 1 | ±3 ms |

Contact voltage

| Measuring range (V) | Resolution (V) | Accuracy |
|---------------------|----------------|---------------------------------------|
| 0.0 ÷ 19.9 | 0.1 | (-0 % / +15 %) of reading ± 10 digits |
| 20.0 ÷ 99.9 | 0.1 | (-0 % / +15 %) of reading |

The accuracy is valid if mains voltage is stable during the measurement and PE terminal is free of interfering voltages.

Trip-out measurement is not available for $I_{\Delta N}=1000$ mA (RCD types B, B+).

Specified accuracy is valid for complete operating range.

8.4 Fault loop impedance and prospective fault current

8.4.1 No disconnecting device or FUSE selected

Fault loop impedance

Measuring range according to EN61557 is $0.25 \Omega \div 9.99 \text{ k}\Omega$.

| Measuring range (Ω) | Resolution (Ω) | Accuracy |
|------------------------------|-------------------------|------------------------------|
| 0.00 ÷ 9.99 | 0.01 | ±(5 % of reading + 5 digits) |
| 10.0 ÷ 99.9 | 0.1 | |
| 100 ÷ 999 | 1 | |
| 1.00k ÷ 9.99k | 10 | ± 10 % of reading |

Prospective fault current (calculated value)

| Measuring range (A) | Resolution (A) | Accuracy |
|---------------------|----------------|--|
| 0.00 ÷ 9.99 | 0.01 | Consider accuracy of fault loop resistance measurement |
| 10.0 ÷ 99.9 | 0.1 | |
| 100 ÷ 999 | 1 | |
| 1.00k ÷ 9.99k | 10 | |
| 10.0k ÷ 23.0k | 100 | |

The accuracy is valid if mains voltage is stable during the measurement.

Test current (at 230 V)..... 6.5 A (10 ms)

Nominal voltage range..... 93 V ÷ 134 V (45 Hz ÷ 65 Hz)

185 V ÷ 266 V (45 Hz ÷ 65 Hz)

8.4.2 RCD selected

Fault loop impedance

Measuring range according to EN61557 is 0.46 Ω ÷ 9.99 k Ω .

| Measuring range (Ω) | Resolution (Ω) | Accuracy |
|------------------------------|-------------------------|-----------------------------------|
| 0.00 ÷ 9.99 | 0.01 | $\pm(5\%$ of reading + 10 digits) |
| 10.0 ÷ 99.9 | 0.1 | |
| 100 ÷ 999 | 1 | $\pm 10\%$ of reading |
| 1.00k ÷ 9.99k | 10 | |

Accuracy may be impaired in case of heavy noise on mains voltage

Prospective fault current (calculated value)

| Measuring range (A) | Resolution (A) | Accuracy |
|---------------------|----------------|--|
| 0.00 ÷ 9.99 | 0.01 | Consider accuracy of fault loop resistance measurement |
| 10.0 ÷ 99.9 | 0.1 | |
| 100 ÷ 999 | 1 | |
| 1.00k ÷ 9.99k | 10 | |
| 10.0k ÷ 23.0k | 100 | |

Nominal voltage range..... 93 V ÷ 134 V (45 Hz ÷ 65 Hz)

185 V ÷ 266 V (45 Hz ÷ 65 Hz)

No trip out of RCD.

8.5 Line impedance and prospective short-circuit current / Voltage drop

Line impedance

Measuring range according to EN61557 is 0.25 Ω ÷ 9.99k Ω .

| Measuring range (Ω) | Resolution (Ω) | Accuracy |
|------------------------------|-------------------------|----------------------------------|
| 0.00 ÷ 9.99 | 0.01 | $\pm(5\%$ of reading + 5 digits) |
| 10.0 ÷ 99.9 | 0.1 | |
| 100 ÷ 999 | 1 | $\pm 10\%$ of reading |

| | | |
|---------------|----|--|
| 1.00k ÷ 9.99k | 10 | |
|---------------|----|--|

Prospective short-circuit current (calculated value)

| Measuring range (A) | Resolution (A) | Accuracy |
|---------------------|----------------|--|
| 0.00 ÷ 0.99 | 0.01 | Consider accuracy of line resistance measurement |
| 1.0 ÷ 99.9 | 0.1 | |
| 100 ÷ 999 | 1 | |
| 1.00k ÷ 99.99k | 10 | |
| 100k ÷ 199k | 1000 | |

Test current (at 230 V)..... 6.5 A (10 ms)

Nominal voltage range..... 93 V ÷ 134 V (45 Hz ÷ 65 Hz)

185 V ÷ 266 V (45 Hz ÷ 65 Hz)

321 V ÷ 485 V (45 Hz ÷ 65 Hz)

Voltage drop (calculated value)

| Measuring range (%) | Resolution (%) | Accuracy |
|---------------------|----------------|---|
| 0.0 ÷ 99.9 | 0.1 | Consider accuracy of line impedance measurement(s)* |

Z_{REF} measuring range 0.00 Ω ÷ 20.0 Ω

*See chapter 5.8.2 Voltage drop for more information about calculation of voltage drop result.

8.6 Resistance to earth

Measuring range according to EN61557-5 is 0.25 Ω ÷ 1999 Ω.

| Measuring range (Ω) | Resolution (Ω) | Accuracy |
|---------------------|----------------|-----------------------------|
| 0.00 ÷ 19.99 | 0.01 | ±(5% of reading + 5 digits) |
| 20.0 ÷ 199.9 | 0.1 | |
| 200 ÷ 9999 | 1 | |

Max. auxiliary earth electrode resistance R_C ... 100×R_E or 50 kΩ (whichever is lower)

Max. probe resistance R_P 100×R_E or 50 kΩ (whichever is lower)

Additional probe resistance error at R_{Cmax} or R_{Pmax}. ±(10 % of reading + 10 digits)

Additional error

at 3 V voltage noise (50 Hz) ±(5 % of reading + 10 digits)

Open circuit voltage < 15 VAC

Short circuit current..... < 30 mA

Test voltage frequency 125 Hz

Test voltage shape sinusoidal

Noise voltage indication threshold 1 V (< 50 Ω, worst case)

Automatic measurement of auxiliary electrode resistance and probe resistance.
Automatic measurement of voltage noise.

8.7 Voltage, frequency, and phase rotation

8.7.1 Phase rotation

Nominal system voltage range 100 V_{AC} ÷ 550 V_{AC}
Nominal frequency range..... 14 Hz ÷ 500 Hz
Result displayed 1.2.3 or 3.2.1

8.7.2 Voltage

| Measuring range (V) | Resolution (V) | Accuracy |
|---------------------|----------------|------------------------------|
| 0 ÷ 550 | 1 | ±(2 % of reading + 2 digits) |

Result type..... True r.m.s. (trms)
Nominal frequency range..... 0 Hz, 14 Hz ÷ 500 Hz

8.7.3 Frequency

| Measuring range (Hz) | Resolution (Hz) | Accuracy |
|----------------------|-----------------|-------------------------------|
| 0.00 ÷ 9.99 | 0.01 | ±(0.2 % of reading + 1 digit) |
| 10.0 ÷ 499.9 | 0.1 | |

Nominal voltage range..... 10 V ÷ 550 V

8.7.4 Online terminal voltage monitor

| Measuring range (V) | Resolution (V) | Accuracy |
|---------------------|----------------|------------------------------|
| 10 ÷ 550 | 1 | ±(2 % of reading + 2 digits) |

8.8 General data

Power supply voltage..... 9 V_{DC} (6×1.5 V battery or accu, size AA)
Operation..... typical 20 h
Charger socket input voltage 12 V ± 10 %
Charger socket input current 400 mA max.
Battery charging current 250 mA (internally regulated)
Overvoltage category..... 600 V CAT III / 300 V CAT IV
Plug test cable
 overvoltage category 300 V CAT II
Protection classification double insulation
Pollution degree..... 2
Protection degree IP 40
Display 128x64 dots matrix display with backlight

| | |
|----------------------------------|--|
| Dimensions (w × h × d) | 14 cm × 8 cm × 23 cm |
| Weight | 1.0 kg, without battery cells |
| Reference conditions | |
| Reference temperature range..... | 10 °C ÷ 30 °C |
| Reference humidity range..... | 40 %RH ÷ 70 %RH |
| Operation conditions | |
| Working temperature range | 0 °C ÷ 40 °C |
| Maximum relative humidity | 95 %RH (0 °C ÷ 40 °C), non-condensing |
| Storage conditions | |
| Temperature range | -10 °C ÷ +70 °C |
| Maximum relative humidity | 90 %RH (-10 °C ÷ +40 °C) 80 %RH (40 °C ÷ 60 °C) |
| Communication transfer speed | |
| RS 232 | 115200 baud |
| USB | 256000 baud |
| Memory size..... | 1700 results |

Bluetooth module: Class 2

The error in operating conditions could be at most the error for reference conditions (specified in the manual for each function) +1 % of measured value + 1 digit, unless otherwise specified in the manual for particular function.

A Appendix A - Fuse table

A.1 Fuse table - impedances (UK)

Fuse type B

| Rated current (A) | Disconnection time [s] | | Rated current (A) | Disconnection time [s] | |
|-------------------|----------------------------------|--------|-------------------|----------------------------------|-------|
| | 0.4 | 5 | | 0.4 | 5 |
| | Max. loop impedance (Ω) | | | Max. loop impedance (Ω) | |
| 3 | 12,264 | 12,264 | | | |
| 6 | 6,136 | 6,136 | 6 | 3,064 | 3,064 |
| 10 | 3,68 | 3,68 | 10 | 1,84 | 1,84 |
| 16 | 2,296 | 2,296 | 16 | 1,152 | 1,152 |
| 20 | 1,84 | 1,84 | 20 | 0,92 | 0,92 |
| 25 | 1,472 | 1,472 | 25 | 0,736 | 0,736 |
| 32 | 1,152 | 1,152 | 32 | 0,576 | 0,576 |
| 40 | 0,92 | 0,92 | 40 | 0,456 | 0,456 |
| 50 | 0,736 | 0,736 | 50 | 0,368 | 0,368 |
| 63 | 0,584 | 0,584 | 63 | 0,288 | 0,288 |
| 80 | 0,456 | 0,456 | 80 | 0,232 | 0,232 |
| 100 | 0,368 | 0,368 | 100 | 0,184 | 0,184 |
| 125 | 0,296 | 0,296 | 125 | 0,144 | 0,144 |

Fuse type C

| Rated current (A) | Disconnection time [s] | | Rated current (A) | Disconnection time [s] | |
|-------------------|----------------------------------|-------|-------------------|----------------------------------|--------|
| | 0.4 | 5 | | 0.4 | 5 |
| | Max. loop impedance (Ω) | | | Max. loop impedance (Ω) | |
| 6 | 1,536 | 1,536 | 5 | 8,36 | 12,264 |
| 10 | 0,92 | 0,92 | 16 | 1,936 | 3,288 |
| 16 | 0,576 | 0,576 | 20 | 1,632 | 2,704 |
| 20 | 0,456 | 0,456 | 32 | 0,768 | 1,312 |
| 25 | 0,368 | 0,368 | 45 | | 0,832 |
| 32 | 0,288 | 0,288 | 63 | | 0,576 |
| 40 | 0,232 | 0,232 | 80 | | 0,424 |
| 50 | 0,184 | 0,184 | 100 | | 0,32 |
| 63 | 0,144 | 0,144 | | | |
| 80 | 0,112 | 0,112 | | | |
| 100 | 0,088 | 0,088 | | | |
| 125 | 0,072 | 0,072 | | | |

Fuse type D

Fuse type BS 88-3 (system C)

| Rated current (A) | Disconnection time [s] | | Rated current (A) | Disconnection time [s] | |
|-------------------|----------------------------------|-------|-------------------|----------------------------------|-------|
| | 0.4 | 5 | | 0.4 | 5 |
| | Max. loop impedance (Ω) | | | Max. loop impedance (Ω) | |
| 6 | 6,568 | 10,24 | 3 | 13,12 | 18,56 |
| 10 | 3,912 | 5,752 | 13 | 1,936 | 3,064 |
| 16 | 2,048 | 3,344 | | | |
| 20 | 1,416 | 2,36 | | | |
| 25 | 1,08 | 1,84 | | | |
| 32 | 0,832 | 1,472 | | | |
| 40 | | 1,08 | | | |
| 50 | | 0,832 | | | |
| 63 | | 0,656 | | | |
| 80 | | 0,456 | | | |
| 100 | | 0,368 | | | |
| 125 | | 0,272 | | | |
| 160 | | 0,224 | | | |
| 200 | | 0,152 | | | |

Fuse type BS 88-2 (systems E and G)

Fuse type BS 1362

| Rated current (A) | Disconnection time [s] | | Rated current (A) | Disconnection time [s] | |
|-------------------|----------------------------------|-------|-------------------|----------------------------------|-------|
| | 0.4 | 5 | | 0.4 | 5 |
| | Max. loop impedance (Ω) | | | Max. loop impedance (Ω) | |
| 6 | 6,568 | 10,24 | 3 | 13,12 | 18,56 |
| 10 | 3,912 | 5,752 | 13 | 1,936 | 3,064 |
| 16 | 2,048 | 3,344 | | | |
| 20 | 1,416 | 2,36 | | | |
| 25 | 1,08 | 1,84 | | | |
| 32 | 0,832 | 1,472 | | | |
| 40 | | 1,08 | | | |
| 50 | | 0,832 | | | |
| 63 | | 0,656 | | | |
| 80 | | 0,456 | | | |
| 100 | | 0,368 | | | |
| 125 | | 0,272 | | | |
| 160 | | 0,224 | | | |
| 200 | | 0,152 | | | |

Fuse type BS 3036

| Rated current (A) | Disconnection time [s] | | Rated current (A) | Disconnection time [s] | |
|-------------------|----------------------------------|-------|-------------------|----------------------------------|-------|
| | 0.4 | 5 | | 0.4 | 5 |
| | Max. loop impedance (Ω) | | | Max. loop impedance (Ω) | |
| 5 | 7,664 | 14,16 | 5 | 7,664 | 14,16 |
| 15 | 2,04 | 4,28 | 15 | 2,04 | 4,28 |
| 20 | 1,416 | 3,064 | 20 | 1,416 | 3,064 |
| 30 | 0,872 | 2,112 | 30 | 0,872 | 2,112 |
| 45 | | 1,272 | 45 | | 1,272 |
| 60 | | 0,896 | 60 | | 0,896 |
| 100 | | 0,424 | 100 | | 0,424 |

All impedances are scaled with factor 0.8.

B Appendix B - Accessories for specific measurements

The table below presents standard and optional accessories required for specific measurement. The accessories marked as optional may also be standard ones in some sets. Please see attached list of standard accessories for your set or contact your distributor for further information.

| Function | Suitable accessories (Optional with ordering code A....) |
|-----------------------|---|
| Insulation resistance | <input type="checkbox"/> Universal test cable <input type="checkbox"/> Tip commander (A 1401) |
| Continuity | <input type="checkbox"/> Universal test cable <input type="checkbox"/> Tip commander (A 1401) <input type="checkbox"/> Probe test lead 4m (A 1154) |
| Ring Continuity | <input type="checkbox"/> Universal test cable <input type="checkbox"/> Mains measuring cable <input type="checkbox"/> Easy switch (A 1214) |
| Line impedance | <input type="checkbox"/> Universal test cable <input type="checkbox"/> Mains measuring cable <input type="checkbox"/> Plug commander (A 1314-UK) <input type="checkbox"/> Tip commander (A 1401) <input type="checkbox"/> Three-phase adapter (A 1110) <input type="checkbox"/> Three-phase adapter with switch (A 1111) |
| Fault loop impedance | <input type="checkbox"/> Universal test cable <input type="checkbox"/> Mains measuring cable <input type="checkbox"/> Plug commander (A 1314-UK) <input type="checkbox"/> Tip commander (A 1401) <input type="checkbox"/> Three-phase adapter (A 1110) <input type="checkbox"/> Three-phase adapter with switch (A 1111) |
| RCD testing | <input type="checkbox"/> Universal test cable <input type="checkbox"/> Mains measuring cable <input type="checkbox"/> Plug commander (A 1314-UK) <input type="checkbox"/> Three-phase adapter (A 1110) <input type="checkbox"/> Three-phase adapter with switch (A 1111) |
| Earth resistance, RE | <input type="checkbox"/> Universal test cable <input type="checkbox"/> Earth test set 20 m, 3-wire (S 2026) <input type="checkbox"/> Earth test set 50 m, 3-wire (S 2027) |
| Phase sequence | <input type="checkbox"/> Universal test cable <input type="checkbox"/> Three-phase adapter (A 1110) <input type="checkbox"/> Three-phase adapter with switch (A 1111) |
| Voltage, frequency | <input type="checkbox"/> Universal test cable <input type="checkbox"/> Mains measuring cable <input type="checkbox"/> Plug commander (A 1314-UK) <input type="checkbox"/> Tip commander (A 1401) |

C Appendix C – Commanders (A 1314-UK, A 1401)

C.1 Warnings related to safety

Measuring category of commanders:

Plug commander A 1314-UK 300 V CAT II

Tip commander A 1401

(cap off, 18 mm tip) 1000 V CAT II / 600 V CAT II / 300 V CAT II

(cap on, 4 mm tip)...1000 V CAT II / 600 V CAT III / 300 V CAT IV

- ❑ Measuring category of commanders can be lower than protection category of the instrument.
- ❑ If dangerous voltage is detected on the tested PE terminal, immediately stop all measurements, find and remove the fault!
- ❑ When replacing battery cells or before opening the battery compartment cover, disconnect the measuring accessory from the instrument and installation.
- ❑ Service, repairs or adjustment of instruments and accessories is only allowed to be carried out by a competent authorized personnel!

C.2 Battery

The commander uses two AAA size alkaline or rechargeable Ni-MH battery cells.

Nominal operating time is at least 40 h and is declared for cells with nominal capacity of 850 mAh.

Notes:

- ❑ If the commander is not used for a long period of time, remove all batteries from the battery compartment.
- ❑ Alkaline or rechargeable Ni-MH batteries (size AA) can be used. Metrel recommends only using rechargeable batteries with a capacity of 800 mAh or above.
- ❑ Ensure that the battery cells are inserted correctly otherwise the commander will not operate and the batteries could be discharged.

C.3 Description of commanders

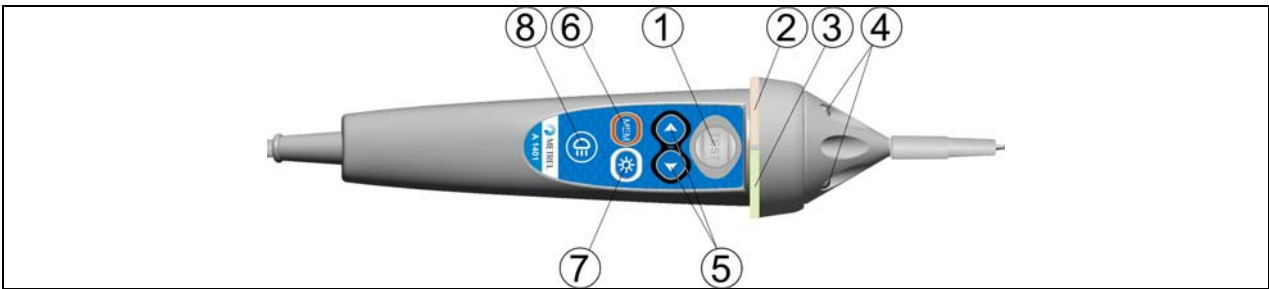

Figure C.1: Front side tip commander

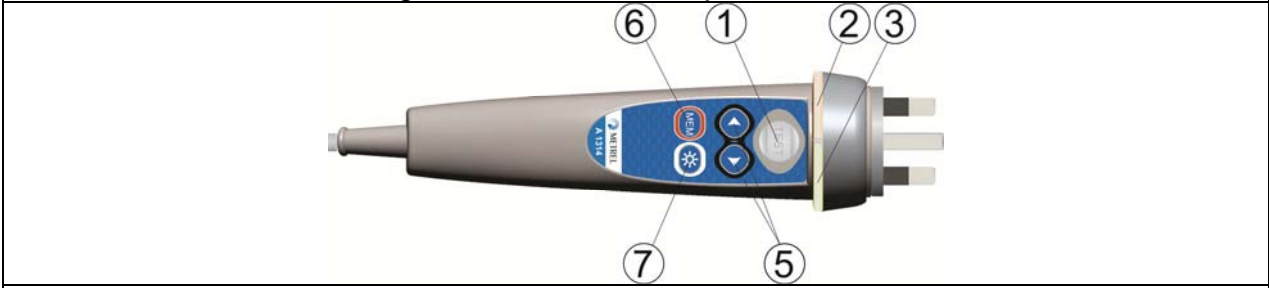

Figure C.2: Front side plug commander (A 1314-UK)

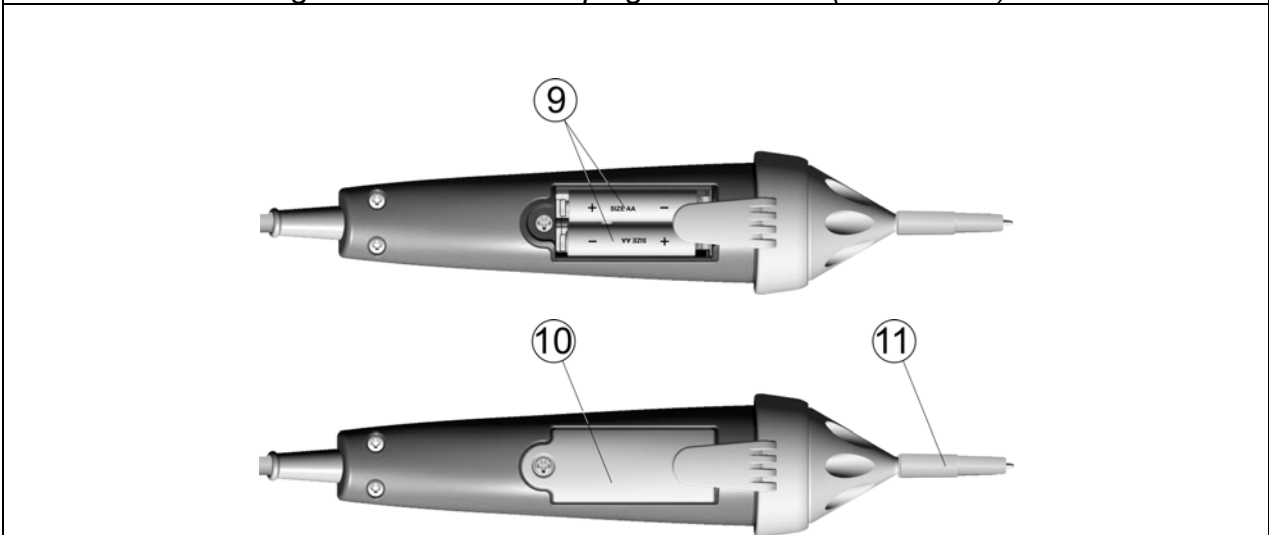

Figure C.3: Back side

Legend:

| | | | |
|---|-------------------|---|---|
| 1 | TEST | TEST | Starts measurements. Acts also as the PE touching electrode. |
| 2 | LED | Left status | RGB LED |
| 3 | LED | Right status | RGB LED |
| 4 | LEDs | Lamp LEDs (Tip commander) | |
| 5 | Function selector | Selects test function. | |
| 6 | MEM | Store / recall / clear tests in memory of instrument. | |
| 7 | BL | Switches On/Off backlight on instrument | |
| 8 | Lamp key | Switches On/ Off lamp (Tip commander) | |
| 9 | Battery cells | Size AAA, alkaline / rechargeable NiMH | |

| | | |
|----|---------------|--------------------------------------|
| 10 | Battery cover | Battery compartment cover |
| 11 | Cap | Removable CAT IV cap (Tip commander) |

C.4 Operation of commanders

| | |
|------------------------------|---|
| Both LED yellow | Warning! Dangerous voltage on the commander's PE terminal! |
| Right LED red | Fail indication |
| Right LED green | Pass indication |
| Left LED blinks blue | Commander is monitoring the input voltage |
| Left LED orange | Voltage between any test terminals is higher than 50 V |
| Both LEDs blink red | Low battery |
| Both LEDs red and switch off | Battery voltage too low for operation of commander |

PE terminal test procedure

- ❑ **Connect** commander to the instrument.
- ❑ **Connect** commander to the item to be tested (see **Error! Reference source not found.** and C.5).
- ❑ Touch PE test probe (the **TEST** key) on commander for at least one second.
- ❑ If PE terminal is connected to phase voltage both LEDs will light yellow, the warning message on the instrument is displayed, instrument's buzzer is activated, and further measurements are disabled in Zloop function.

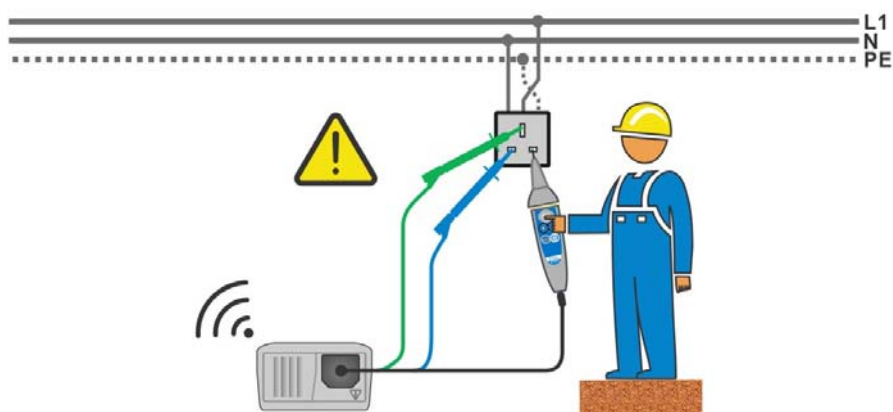

Figure C.4: Reversed L and PE conductors (application of tip commander)

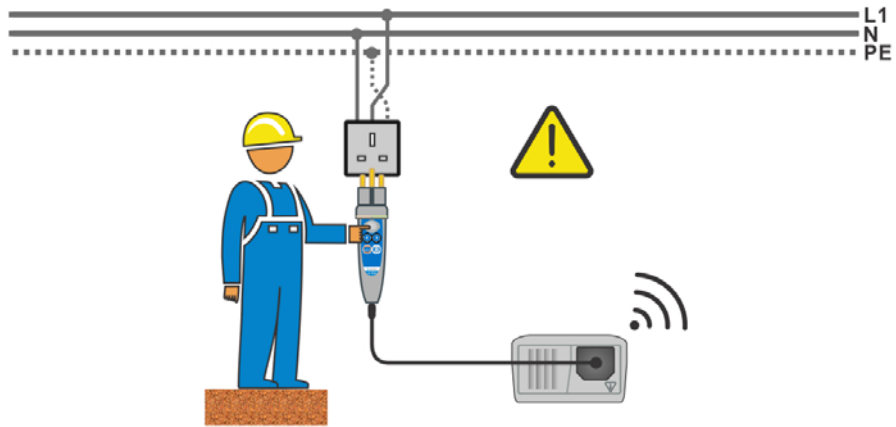

Figure C.5: Reversed L and PE conductors (application of plug commander)



Reversed phase and protection conductors! The most dangerous situation!