



STM32L-DISCOVERY: current consumption measurement and touch sensing demonstration

Introduction

This application note provides an overview of the demonstration firmware delivered with the STM32L-DISCOVERY evaluation board. It allows you to explore the rich set of power saving modes available in the STM32L microcontroller by using the STM32L-DISCOVERY embedded IDD measurement circuit that is used to demonstrate the real capabilities of the ultra low power microcontroller STM32L.

The demonstration application does not require any additional hardware. Once the STM32L-DISCOVERY is powered-up through a USB cable connected to the host PC, the application is ready to display the STM32L power consumption of each low-power modes selected by the user.

In addition the demonstration firmware allow you to explore touch sensing capabilities of STM32L microcontroller demonstrated by sensing of linear touch sensor or set of four touchkeys.

Reference documents

- STM32L-DISCOVERY evaluation board user manual (UM1079)
- STM32L151xx and STM32L152xx Flash and EEPROM programming (PM0062)

The above documents are available at <http://www.st.com>.

Contents

- 1 Application description 3**
 - 1.1 Used hardware components 3
 - 1.2 STM32L-DISCOVERY hardware settings 3
 - 1.3 Application schematics 3
 - 1.4 Application principle 4
 - 1.4.1 Overview 4
 - 1.4.2 I_{DD} measurement principle 4
 - 1.5 Getting started with the application 6
 - 1.5.1 Demo mode - Touch sensing demonstration and I_{DD} measurement 6
 - 1.5.2 Bias current record 8
 - 1.5.3 Manufacturing test 8
 - 1.6 Low power modes 9

- 2 Software description 10**
 - 2.1 STM32L peripherals used by the application 10
 - 2.2 STM32L15x standard firmware library configuration 11
 - 2.3 Application software flow 11
 - 2.3.1 Main application 11
 - 2.3.2 Demo mode (I_{DD} measurement) 11

- 3 Conclusion 16**

- 4 Revision history 17**

1 Application description

1.1 Used hardware components

This application example uses the hardware components available on STM32L-DISCOVERY; on-board LEDs (green LD3 and blue LD4), the 6-digit/4-bar LCD glass display, the user push-button and touch sense slider. No additional components are required.

1.2 STM32L-DISCOVERY hardware settings

The I_{DD} jumper JP1 must be placed in position ON for standard operation (except for bias current record operation, see [Section 1.5.2](#)).

Both jumpers on CN3 must be fitted to allow communication of STM32L15x with ST-Link debugging tool thru SWD interface.

Note: All solder bridges must be in the default state as described in UM1079.

1.3 Application schematics

[Figure 1](#) shows the simplified application electrical schematics.

Figure 1. Application schematics

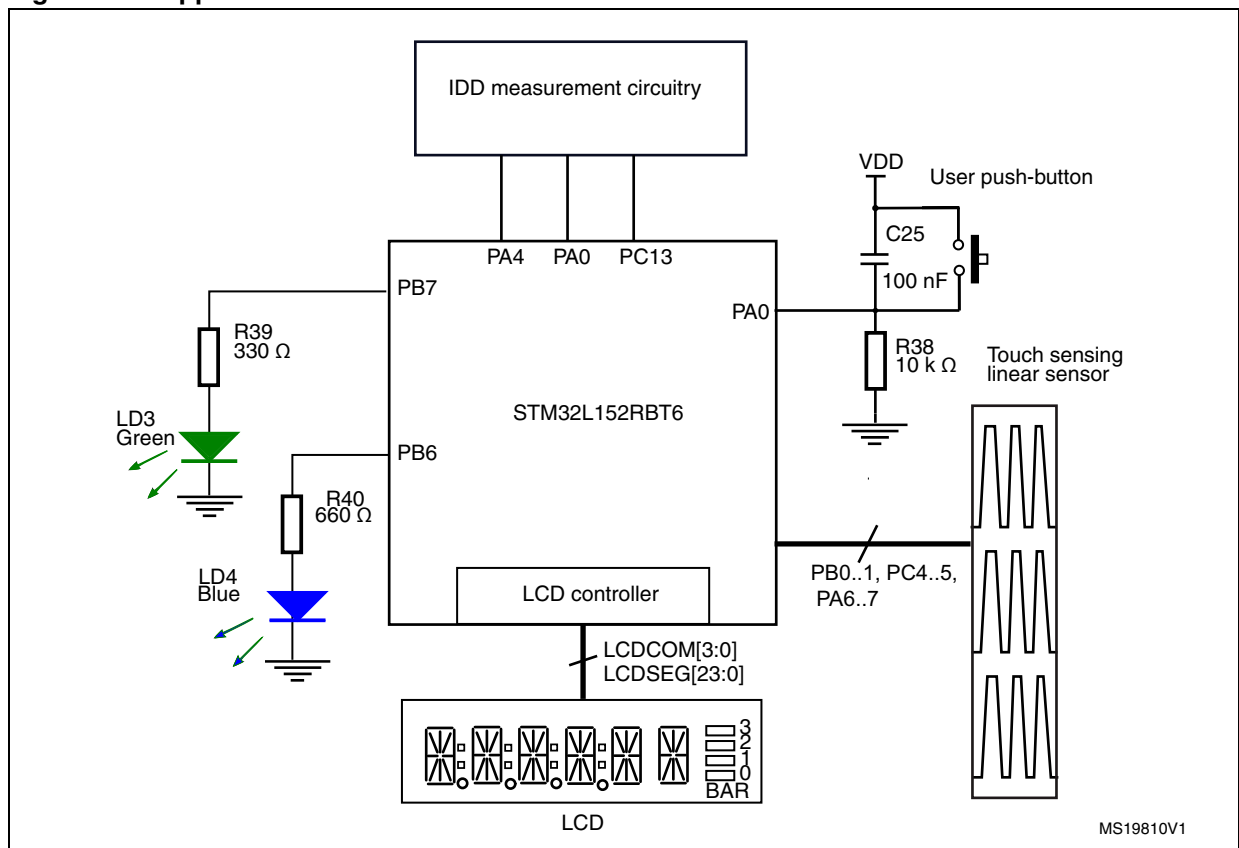

1.4 Application principle

1.4.1 Overview

STM32L-DISCOVERY includes specific analog and logic hardware that is connected to STM32L152 microcontroller and which is intended to measure and display the supply I_{DD} current when the device is placed in different power consumption modes such as:

- Run mode
- Sleep mode
- Low power run mode
- Low power sleep mode
- Stop mode with operating RTC
- Stop mode without RTC
- Standby mode

The user reads the value displayed on the STM32L-DISCOVERY's LCD panel, to know how much power the device is currently consuming.

With this demonstration, you can obtain an overview of low power modes and supply current requirements for each low power mode available on STM32L152.

The firmware associated with this application note also provides a demonstration of the touch sensing functionality available on STM32L-DISCOVERY. The touch sensing electrodes can be configured either as a linear touch sensor to perform linear sensing of finger position displayed as a percentage on the LCD, or, it can be configured as a group of four independent touchkeys.

It also includes a manufacturing test mode for performing a quick diagnosis of the STM32L-DISCOVERY related to this application example. See [Section 1.5.3: Manufacturing test](#) for details regarding the test activation and for an explanation of the different test modes.

1.4.2 I_{DD} measurement principle

The STM32L-DISCOVERY I_{DD} measurement circuitry consists of measuring the high side shunt voltage value V at the terminals of a high precision serial resistor (1%) inserted between the +3V3 power supply and the V_{DD} pin of the MCU. Depending on the device power modes, the application uses R or $[2000 + 2] \times R$ as the equivalent resistor value by closing or opening K1. In Run mode, the current is in the range of mA, K1 is closed, and the equivalent resistor is R . In low power modes, the current is in the μA range, K1 is opened, and the equivalent resistance is $2002 \times R$.

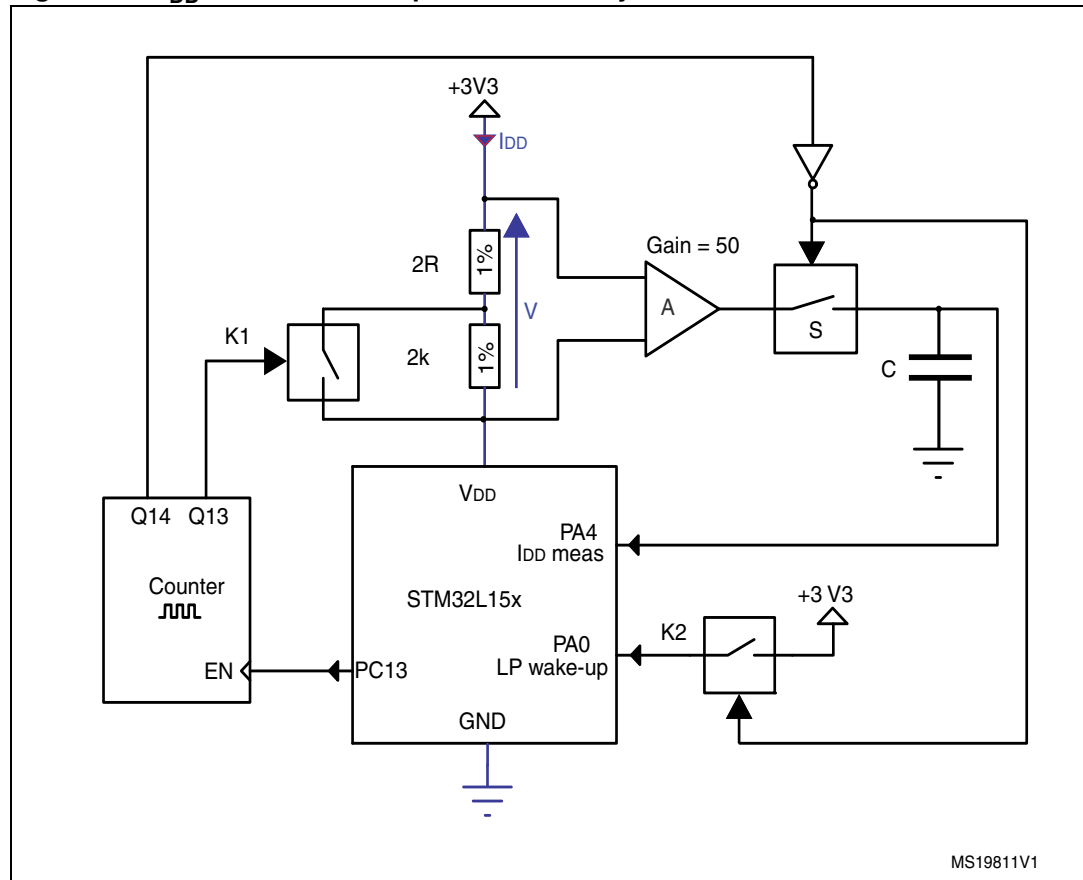
Figure 2. I_{DD} measurement equivalent circuitry

This resistor is connected between the differential inputs of a high-side current sense operational amplifier (A) with a fixed gain that amplifies the voltage (V) present on the resistors. A sample and hold stage is placed at the operational amplifier output and is then connected to an analog input of the MCU (PA4 I_{DD} Measurement) that finally converts the resulting voltage, image of the consumption current.

In low power modes only, a counter enabled by STM32L15x (PC13 pin) manages the measurement timing while the microcontroller is idle. The microcontroller is woken-up after a 150 ms delay when the rising edge is triggered on a wake-up pin (PA0) controlled by the K2 switch.

While the microcontroller is in one of the power saving modes, a capacitor (C) is charged with the voltage amplified by the operational amplifier. The microcontroller can later sample (during its wake-up phase - 50 ms) the value of capacitor voltage proportional to the current consumption of MCU in low power mode. Switch S is opened at device start-up in order to keep the charge collected in capacitor (C) intact while the microcontroller is in low power mode.

The current measurement precision is enhanced by taking into account the current bias of high-side current operational amplifier. When JP1 is placed in OFF position (I_{DD} measurement circuitry disabled), a special test invoked by the user at device start-up measures this current value and stores it in the non-volatile memory. Once this value is stored in the device, it is deducted from the next I_{DD} measurement to compensate errors due to I bias current (see [Section 1.5.2: Bias current record](#)).

For additional information related to the I_{DD} measurement feature, please refer to STM32L-DISCOVERY evaluation board user manual (UM1079).

1.5 Getting started with the application

This STM32L-DISCOVERY example application has 3 application modes that can be run:

- Demo mode (touch sensor, I_{DD} measurement)
- Bias current record
- Manufacturing test

Demo mode is available at application power-up while the two others are invoked by the user using a specific procedure that is described in detail later in this chapter. However, for best performance, it is recommended to measure and record the bias current before starting evaluation of low power mode I_{DD} current.

1.5.1 Demo mode - Touch sensing demonstration and I_{DD} measurement

Once the application is powered-up via the USB cable (or by external power supply), it starts displaying a welcome message and then, after a few seconds, the value of the V_{DD} voltage applied to the STM32L device.

LD3 (green LED) and LD4 (blue LED) blink alternately. As soon as I_{DD} consumption values are displayed, both LEDs are turned off.

The User push-button allows you to change the functions as described in the state diagram in [Figure 3](#).

The first step is a demonstration of the linear touch sensor function followed by a touchkey demo activated by pressing the user button.

When the used push button is pressed again, the power consumption measurement functions are launched. These functions consist of configuring the device for each low power consumption mode and then measuring and displaying the result on the LCD panel.

Figure 3. Function Change state diagram

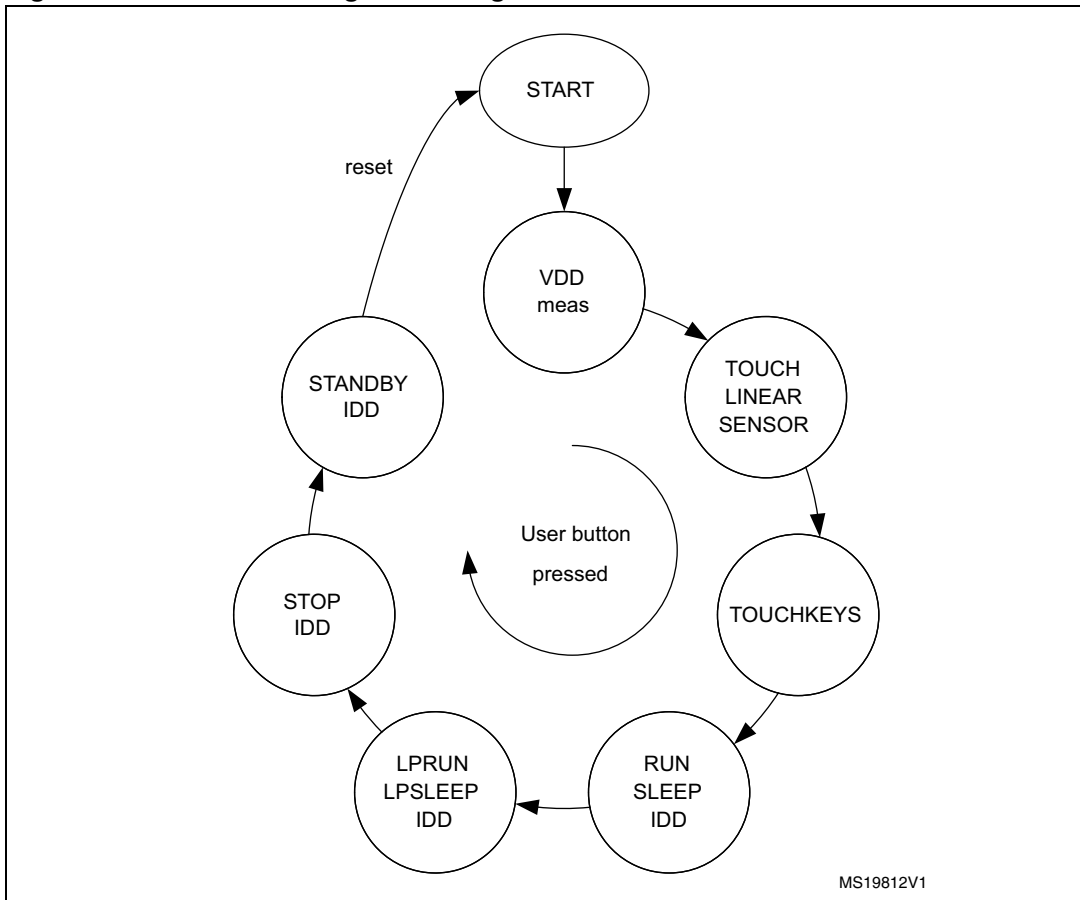

MS19812V1



BAR0 to BAR3 are used by the application to indicate ongoing measurements as shown in [Table 1](#).

In order to save power during the I_{DD} measurement in *Stop mode without LCD*, the LCD is switched off. Once the measurement is performed the LCD is switched on to display the power consumption value.

Table 1. Bars and LCD display linked to functions

Function	Bars
VDD / Linear sensor / Touch buttons	
Run mode / Sleep mode	
Low power run / Low power sleep	

Table 1. Bars and LCD display linked to functions (continued)

Function	Bars
STOP / STOP without LCD	
STANDBY mode	

1.5.2 Bias current record

This operation consists of storing the bias current value of operational amplifier A (see [Figure 2](#)) in the data memory. The bias current value is taken into account for low power measurements in order to minimize measurement errors. Once recorded, this value is kept in non-volatile memory for later use. It is recommended to perform this operation when you start your evaluation in order to obtain the best precision.

This mode is only accessible at application power-up by executing the following steps in the order below:

1. Switch OFF STM32L-DISCOVERY
2. Place JP1 in OFF position (I_{DD} measurement disabled)
3. Keep USER push-button pressed while powering ON the STM32L-DISCOVERY
4. At power on, a scrolling message “Bias Current” is displayed
5. Release the USER push-button; the bias current value is displayed and immediately stored in non-volatile memory

Once this operation completed, replace JP1 in ON position so that the measurement circuitry is connected again to the STM32L152 (I_{DD} measurement enabled).

1.5.3 Manufacturing test

You can access this mode while Demo mode is running, by pressing the USER push-button for more than 3 seconds and by releasing it. This allows you to verify that the hardware modules needed by the STM32L-DISCOVERY for this example are working properly.

In this mode, application checks the LSE oscillator (Low Speed External), V_{DD} voltage value, I_{DD} RUN, OA bias and LP (low power) I_{DD} currents. The currents are tested for lower and upper limits. For each test function, the application displays “OK” and the measured values when available. If all checks are successfully completed, then the message “TEST OK” is continuously displayed. If one of the tests fails, then the application alerts the user by continuously displaying the test name followed by “NO OK”.

To exit this manufacturing test, press the RESET button.

Note: Generally, if the manufacturing test is not successful, first check that JP1 is placed in the ON position and that all solder bridges are in default position. If errors are found in the Low power and Halt modes I_{DD} measurements, the bias current record operation should be performed again.

1.6 Low power modes

The low power modes used in this application are listed below. The microcontroller can be woken up from any power saving mode by an external wake-up event generated by counter U3.

- **Sleep mode:** The CPU is stopped, the peripherals kept running. The system is clocked by the MSI oscillator at a frequency of 4 MHz.
- **Low power run mode:** The CPU and some of the peripherals are running. During Low power run mode, the code is executed from RAM and the CPU is clocked at a frequency of 32 kHz by the MSI oscillator. Flash and data EEPROM are stopped and the voltage regulator is configured in Ultra low power mode.
- **Low power sleep mode:** The CPU is stopped. The system clock frequency is reduced to 32 kHz. Flash and Data EEPROM are in power down mode and the voltage regulator is configured in Ultra low power mode.
- **Stop mode:** The Core is in deepsleep mode, Flash, Data EEPROM and all clocks except LSE are in power down mode. All peripherals except the LCD are disabled. The voltage regulator is in low power mode.
- **Stop mode without LCD:** This is the same as Stop mode except that the LCD controller is also disabled in this case.
- **Standby mode:** This is the deepest low power mode. The voltage regulator is disabled. Core, peripherals, RAM, Flash and Data EEPROM are powered off. Power is maintained for the RTC registers, backup registers and standby circuitry. Device wake-up is done by an external wake-up event, generating a system reset.

For further information, please refer to *STM32L15x reference manual (RM0038)* and *programming manual (PM0062)* where you can find more details about all the available configurations for each STM32L15x low power mode.

2 Software description

2.1 STM32L peripherals used by the application

This application example uses the following STM32L peripherals with the settings described below:

ADC

ADC performs analog-to-digital conversions of the internal reference voltage (V_{DD} voltage display) and of the voltage coming from the operational amplifier that is the image of I_{DD} current.

- ADC resolution: 12-bit
- ADC conversion mode: single
- ADC sampling time: 192 cycles

SYSTICK Timer

The Systick timer is used to generate the delay needed for display or wait loops.

GPIOs

Port C and Port E are connected to the USER push-button and the LEDs.

- PB1 set as an input floating pin with interrupt connected to the USER push-button
- PB7 (green LD3) and PB6 (blue LD4) set as an output push-pull
- PA0 set as a wake-up pin configured either as an input floating pin with interrupt with detection on rising edge or as an alternate function AFIO0 (WKUP1) during Standby mode.
- PA6, PA7, PC4, PC5, PB0, PB1 are used for linear touch sensor or touchkeys during the touch sensor demonstration.
- During the low power modes, I/Os are placed in analog input mode to reduce power consumption except for a few pins related to the hardware interface (PB7 - green LD3, PB6 - blue LD4, PA4 - I_{DD} measurement pin, PA0 - LP WakeUp pin and PC13 - I_{DD} timer enable). This means that all Schmitt triggers on unused standard I/O pins are disabled to reduce power consumption.

LCD controller

The different functions available in the firmware library for LCD are used to initialize, clear, display strings and scrolling messages needed in the application code. For some low power mode measurements, the LCD controller is turned OFF to minimize the current consumption of the STM32L152.

Clock

The MSI (the multi speed internal oscillator) oscillator is selected as clock source. The application manages the peripheral clocks depending on the selected power saving mode. When the device enters low power run mode, MSI is switched OFF and LSE acts as the main clock source until the device is woken-up by an external event. When exiting Low power run mode, the MCU switches the MSI oscillator back ON. LSE is switched ON during Manufacturing test mode (see [Section 1.5.3](#)) to check its functionality.

2.2 STM32L15x standard firmware library configuration

The *stm32l1xx_conf.h* file of the STM32L standard firmware library allows you to configure the library by enabling the peripheral functions used by the application.

The header files of library modules are included in the *stm32l1xx_conf.h* file as listed below.

```
#include stm32l1xx_adc.h
#include stm32l1xx_exti.h
#include stm32l1xx_flash.h
#include stm32l1xx_gpio.h
#include stm32l1xx_syscfg.h
#include stm32l1xx_lcd.h
#include stm32l1xx_pwr.h
#include stm32l1xx_rcc.h
#include stm32l1xx_rtc.h
#include "misc.h"
```

The corresponding library modules has to be present in the project for successful compilation and linking.

2.3 Application software flow

2.3.1 Main application

After powering up the STM32L-DISCOVERY, the initialization of the peripherals and LCD display is performed and then the application immediately checks whether the USER push-button is pressed. If pressed, then the application goes to the Bias current record operation. Otherwise, Demo mode (I_{DD} measurement) is automatically selected. If during Demo mode, the user presses the USER key for more than 3 seconds, then the application enters manufacturing test. To exit manufacturing test, the application needs to be restarted by pressing the RESET button.

2.3.2 Demo mode (I_{DD} measurement)

When Demo mode is launched, it starts displaying a welcome message and then, after a few seconds, the V_{DD} value.

The user then selects one of the I_{DD} measurement functions by pressing successively on the USER pushbutton (as described in [Section 1.5.1](#)).

These functions are mainly divided in 2 steps:

- Configuring the device according to the selected power mode
- I_{DD} measurement and display (this part is common for all power modes)

The Demo mode sequence is as follows:

Figure 4. Demo mode sequence

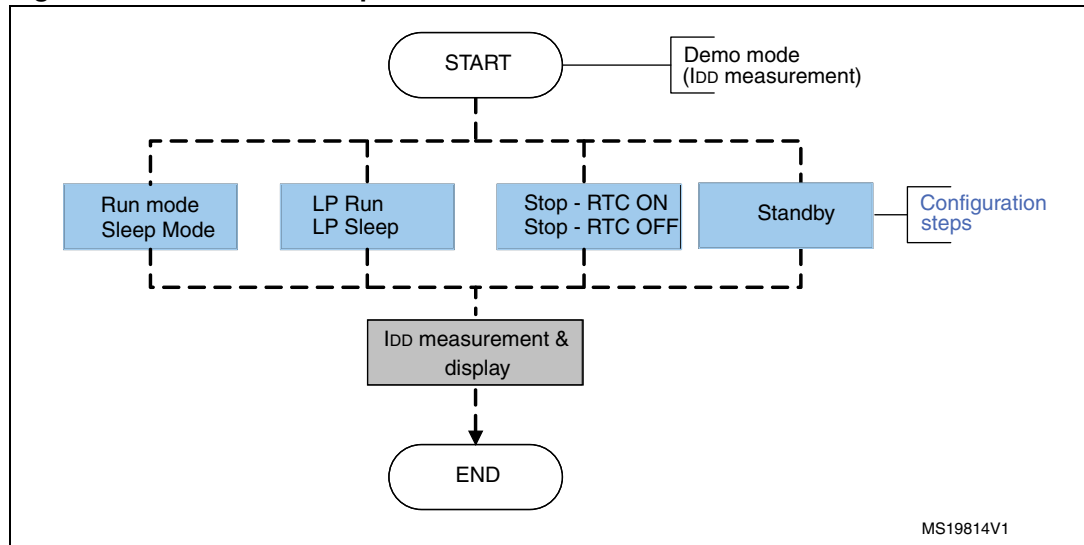

Low power modes configuration

For I_{DD} measurement in Run mode, there is no particular setup needed other than that performed during the STM32L1xx power on initialization. For this function, the application goes directly to I_{DD} measurement and display routine.

The configuration of device for Low power run, Sleep, Stop with and without RTC is detailed in [Figure 5](#). Please, see RM0038 for more details about low power modes available on STM32L1xx.

Figure 5. Low power mode flowchart

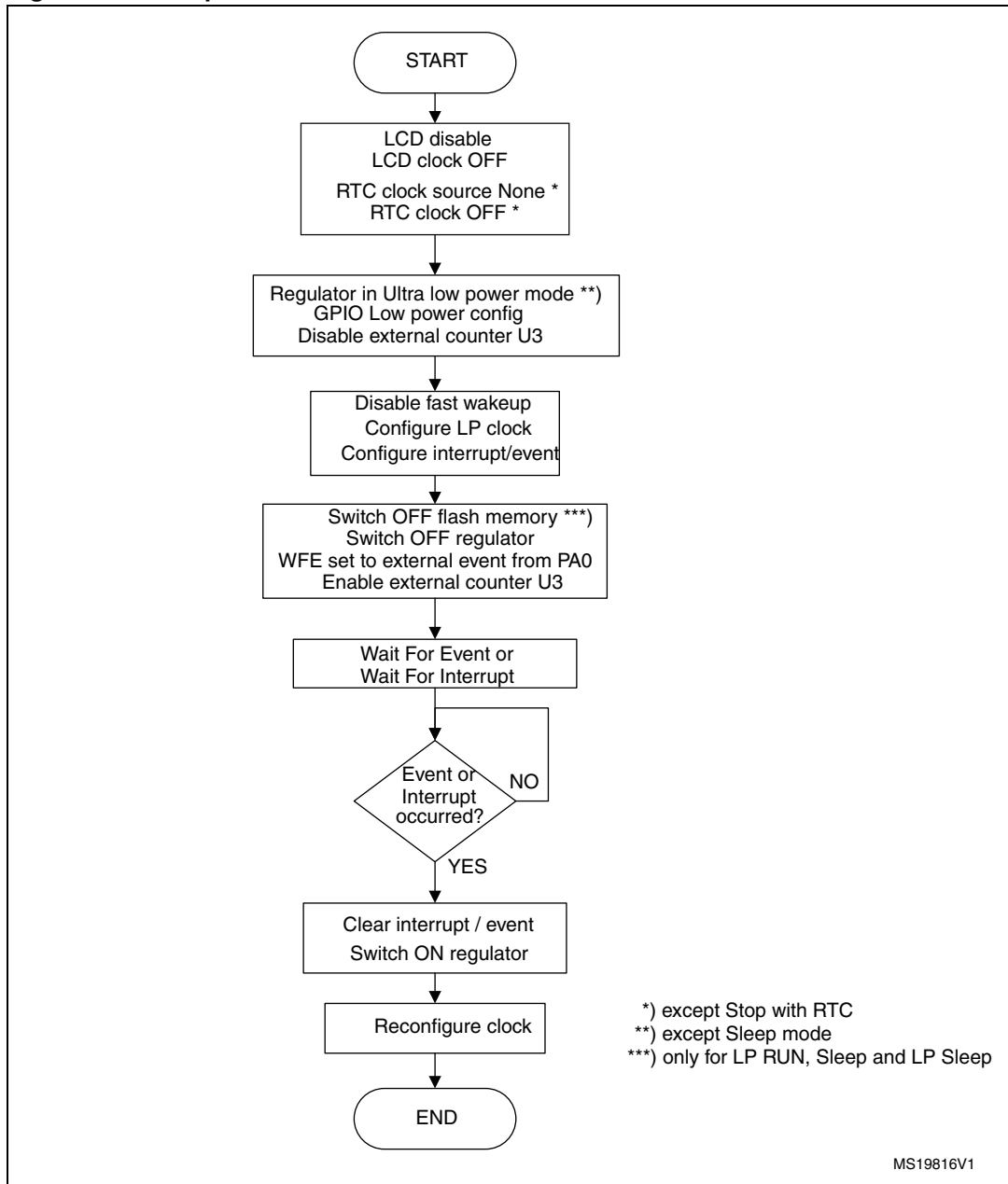

In Standby mode, the device is in its deepest energy saving state. The device enters the Cortex-M3 deepsleep mode and the voltage regulator is disabled. All oscillators are switched off. SRAM and register contents are lost with the exception of the RTC registers, RTC backup registers and Standby circuitry. The device is woken up from this mode by an external wakeup event generated by the U3 counter invoking a system reset.

Figure 6. Standby mode flowchart

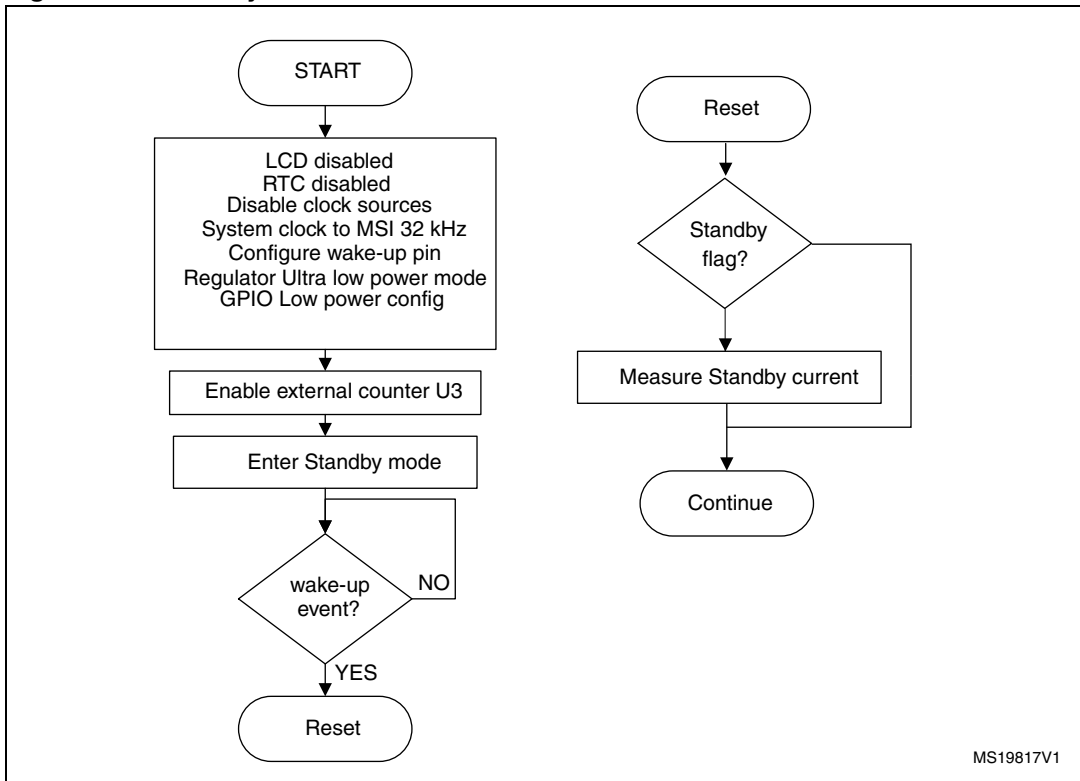

MS19817V1

I_{DD} measurement and display

The following flowchart describes the I_{DD} measurement process.

Figure 7. Measurement and display flowchart

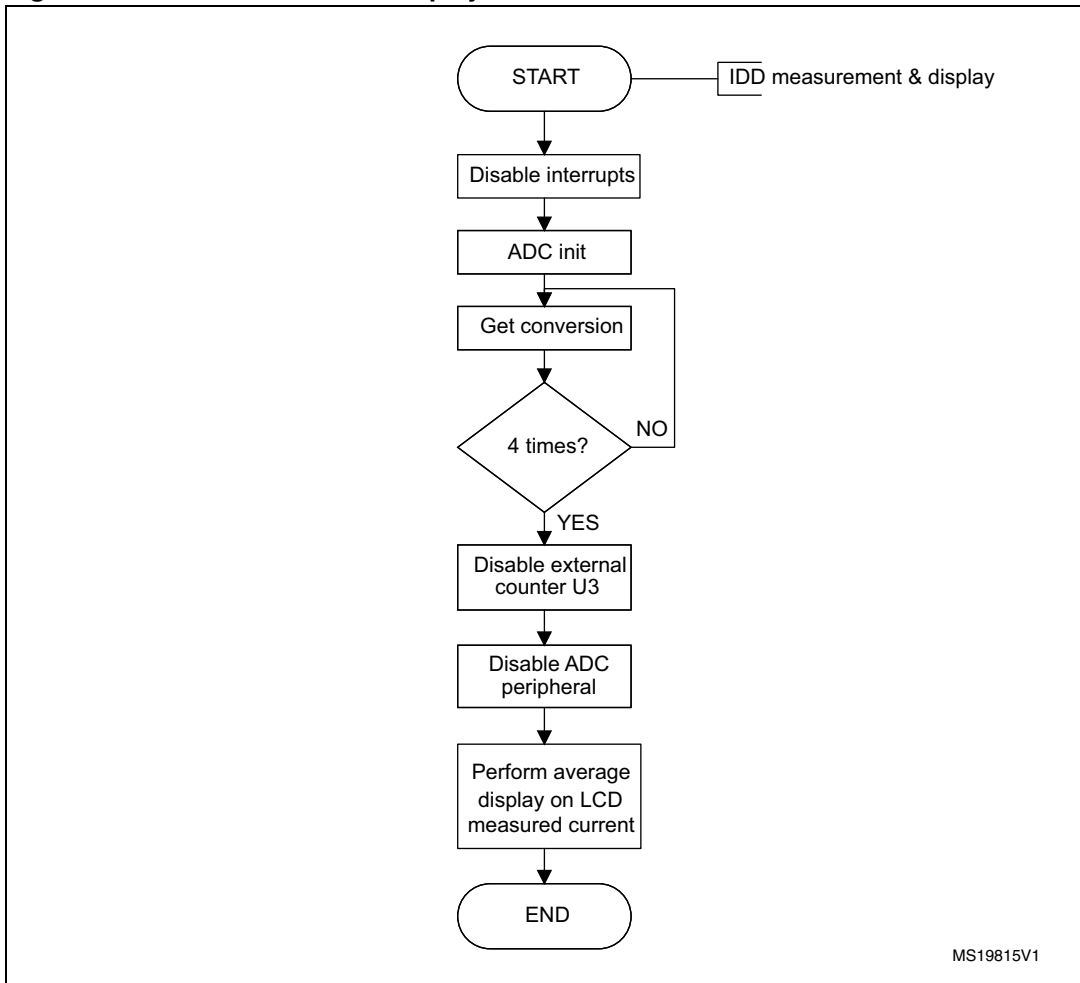

As shown in [Figure 7](#), the ADC conversion is performed 4 times in succession and an average value is computed. The averaged value is displayed on the LCD.

3 Conclusion

This application note shows the demonstration firmware delivered with your STM32L-DISCOVERY kit. This example allows you to evaluate the touch sensing capability of STM32L1xx microcontrollers and demonstrate its ultra low-power features by providing the measured current consumption values in selected low power modes directly on the LCD.

The low-cost STM32L-DISCOVERY kit with the firmware example associated with this application note provides a starting point for your own evaluation of current consumption of application specific tasks running on the ultra low power STM32L microcontroller.

4 Revision history

Table 2. Document revision history

Date	Revision	Changes
04-07-2011	1	Initial release

Please Read Carefully:

Information in this document is provided solely in connection with ST products. STMicroelectronics NV and its subsidiaries ("ST") reserve the right to make changes, corrections, modifications or improvements, to this document, and the products and services described herein at any time, without notice.

All ST products are sold pursuant to ST's terms and conditions of sale.

Purchasers are solely responsible for the choice, selection and use of the ST products and services described herein, and ST assumes no liability whatsoever relating to the choice, selection or use of the ST products and services described herein.

No license, express or implied, by estoppel or otherwise, to any intellectual property rights is granted under this document. If any part of this document refers to any third party products or services it shall not be deemed a license grant by ST for the use of such third party products or services, or any intellectual property contained therein or considered as a warranty covering the use in any manner whatsoever of such third party products or services or any intellectual property contained therein.

UNLESS OTHERWISE SET FORTH IN ST'S TERMS AND CONDITIONS OF SALE ST DISCLAIMS ANY EXPRESS OR IMPLIED WARRANTY WITH RESPECT TO THE USE AND/OR SALE OF ST PRODUCTS INCLUDING WITHOUT LIMITATION IMPLIED WARRANTIES OF MERCHANTABILITY, FITNESS FOR A PARTICULAR PURPOSE (AND THEIR EQUIVALENTS UNDER THE LAWS OF ANY JURISDICTION), OR INFRINGEMENT OF ANY PATENT, COPYRIGHT OR OTHER INTELLECTUAL PROPERTY RIGHT.

UNLESS EXPRESSLY APPROVED IN WRITING BY AN AUTHORIZED ST REPRESENTATIVE, ST PRODUCTS ARE NOT RECOMMENDED, AUTHORIZED OR WARRANTED FOR USE IN MILITARY, AIR CRAFT, SPACE, LIFE SAVING, OR LIFE SUSTAINING APPLICATIONS, NOR IN PRODUCTS OR SYSTEMS WHERE FAILURE OR MALFUNCTION MAY RESULT IN PERSONAL INJURY, DEATH, OR SEVERE PROPERTY OR ENVIRONMENTAL DAMAGE. ST PRODUCTS WHICH ARE NOT SPECIFIED AS "AUTOMOTIVE GRADE" MAY ONLY BE USED IN AUTOMOTIVE APPLICATIONS AT USER'S OWN RISK.

Resale of ST products with provisions different from the statements and/or technical features set forth in this document shall immediately void any warranty granted by ST for the ST product or service described herein and shall not create or extend in any manner whatsoever, any liability of ST.

ST and the ST logo are trademarks or registered trademarks of ST in various countries.

Information in this document supersedes and replaces all information previously supplied.

The ST logo is a registered trademark of STMicroelectronics. All other names are the property of their respective owners.

© 2011 STMicroelectronics - All rights reserved

STMicroelectronics group of companies

Australia - Belgium - Brazil - Canada - China - Czech Republic - Finland - France - Germany - Hong Kong - India - Israel - Italy - Japan - Malaysia - Malta - Morocco - Philippines - Singapore - Spain - Sweden - Switzerland - United Kingdom - United States of America

www.st.com