

***HT119***  
**Handpistol to crimp  
male pin terminals**  
**User's Guide**

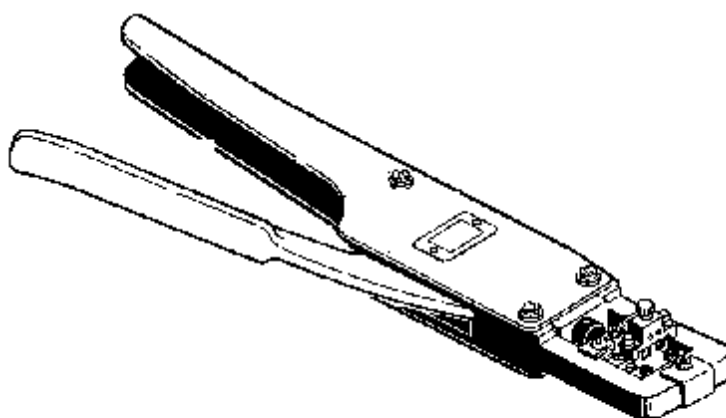

**[www.foehrenbach.be](http://www.foehrenbach.be)**

## CONTENTS

1. INTRODUCTION.....	3
1.1. Hand Tool Function.....	3
1.2. Physical Description.....	3
1.3. Principles of Operation.....	3
1.4. Specifications.....	4
2. OPERATION.....	5
2.1. Operating Procedures.....	5
2.2. Terminal Inspection.....	6
3. TROUBLESHOOTING.....	8
4. PARTS REPLACEMENT PROCEDURES.....	9
4.1. Anvil Replacement.....	9
4.2. Wire and Insulation Barrel Crimpers and Tonker Replacement (see Figure 13).....	11
5. ADJUSTMENT PROCEDURES.....	12
5.1. Crimp Height Adjustment.....	12
6. PARTS.....	13
6.1. Spare Parts.....	13
6.2. Parts Ordering Information.....	13
6.3. Hand Tool Repair Policy.....	13

## 1. INTRODUCTION

### 1.1 Hand Tool Function

The HT-0119 is a manually operated hand tool designed for crimping loose piece (individual) Crimp-to-Wire Male Pin terminals to wire sizes of 22-26 AWG.

### 1.2 Physical Description

The major components that make up the HT-0119 are identified in Figure 1. These include a frame, lever, tooling, tooling holders and a terminal holder. The heart of the hand tool is the tooling. The tooling performs the crimping operation and is divided into top and bottom component groups. The top group consists of those parts which remain stationary with the frame. The bottom group contains those parts that move with the lever. The HT-0119 is equipped with 2 crimping places. Both sides are used for wire sizes from 22-26 AWG.

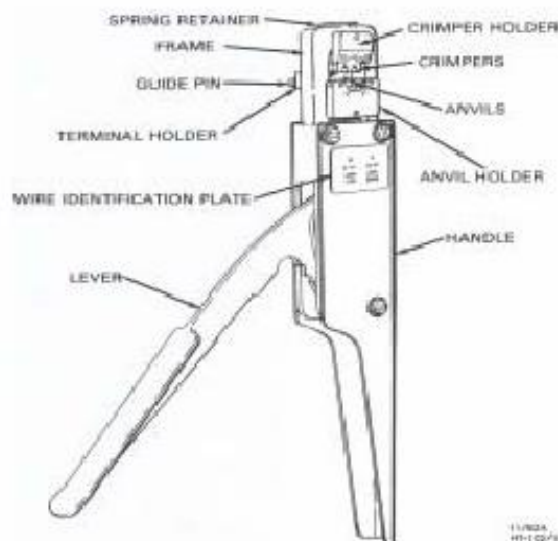

### 1.3 Principles of Operation

The lever attaches to the lower tooling and provides the mechanical advantage to generate the necessary crimping pressure. As the lever is closed, a ratchet mechanism engages to prevent the lever from opening until the crimping cycle is complete.

When the lever is pulled closed, the lower tooling and terminal are pushed up against the upper tooling. The crimp is formed between the wire and insulation barrel anvils and the wire and insulation crimpers.

Once closed, the ratchet releases and allows a spring to pull the lever open

## 1.4 Specifications

When crimping the Male Pin to wires, the following parameters must be met.

- Wire Length Requirements:

- Minimum ..... 19-05 mm (0.75 in.)
- Maximum ..... As Required

- Insulation Diameters of Wires:

Latch Housing and Discrete Applications ..... 0.96-1.52 mm  
(0.038-0.060 in.) Dia.

- Strip Length of Insulation:

Latch Housing and Discrete Applications ..... 3.81-4.32 mm  
(0.150-0.170 in.)

- Wire Barrel Crimp Height:

- Single Wire (22-26 AWG) ..... 0.76-0.81 mm  
(0.030-0.032 in.)

- Insulation Barrel Crimp Height:

- (22-26 AWG) Latch Housing and Discrete Applications..... 1.75 mm  
(0.069 in.) Max. Dia.

### NOTE

Loose piece terminals have different part numbers than reeled terminals

### CAUTION

If the terminal and the tooling are not compatible, damage to the tooling could result. If you wish to use a terminal with a part number other than the one that was ordered for the HT-0119 check with your distributor to be sure that the new terminal number is compatible with your hand tool.

## 2. OPERATION

### 2.1 Operating Procedures

#### WARNING

**To prevent hand injury, keep fingers from between the upper and lower tooling and from between the lever and handle when closing hand tool.**

1. Hold the hand tool so that the lever is on the left. With your index finger, push and hold the terminal holder in its forward position (see Figure 2).

#### NOTE

When inserting a terminal into the terminal holder you will notice a slight drag (interference) on the terminal. The drag is caused by the spring ball plunger (see Figure 13 item no. 21) applying downward pressure on the pin end of the terminal.

This downward pressure helps to orient and hold the terminal in the terminal holder until crimped.

2. Insert the pin end of the terminal, with "U" shaped barrels up, into the terminal holder and against the pin shoulder. While holding the terminal against the shoulder, release the terminal holder. This ensures that the terminal remains in the proper position while moving over the anvil.

3. While grasping the lever and the handle portion of the frame, insert a wire so that the end of the insulation is centered between the wire barrel and the insulation barrel of the terminal (see Figure 3). An alternate method is to position the end of the insulation against the tonker (see Figure 13, item no. 2) which protrudes from between the crimpers (3 & 4). Then close the hand tool lever completely. This will crimp the terminal to the wire(s).

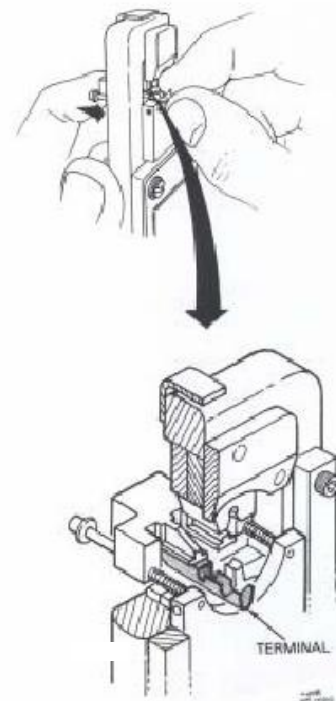

*Figure 2. Positioning Terminal for Crimping*

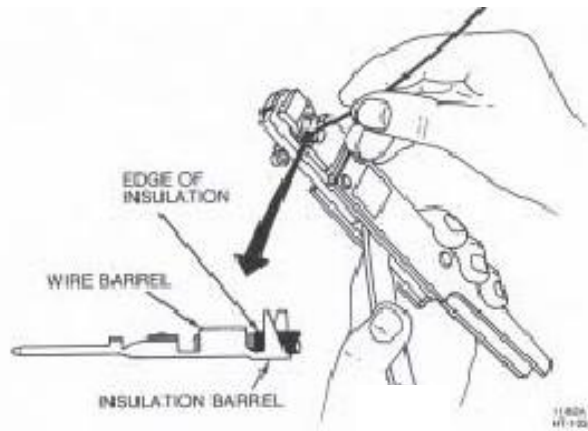

Figure 3. Crimping Terminal to Wire

4. Release the lever to open the hand tool and remove the crimped terminal by lightly pulling straight out on the wire.

#### **CAUTION**

The crimp height for this hand tool was factory adjusted. Any changes to this crimp height adjustment could cause a defective crimp or damage to the tooling.

#### **2.2 Terminal Inspection**

The crimped terminal should be inspected to ensure that the tooling is correctly aligned and that the wire was correctly inserted. Make the following visual checks (see Figure 4).

#### **NOTE**

If inspection of the crimped terminal reveals any defects, the terminal has not been properly crimped and should be discarded.

- Check that all wire strands were crimped within the wire barrel.
- Check that the end of the wire insulation lies between the insulation and the wire barrel.
- Check that the bellmouth(s) were formed correctly.
- Check that the wire barrel seam is even and tightly closed.

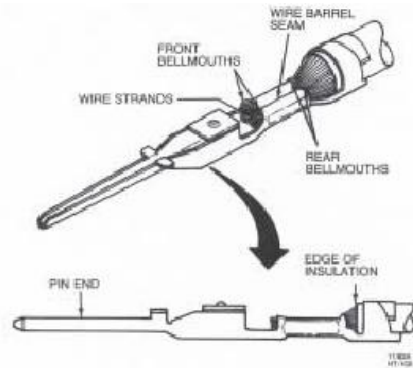

Figure 4. Correctly Crimped Terminal

Next, obtain a crimp height micrometer and measure the areas of the terminal shown in Figure 5. If the crimp heights do not meet the specifications listed in Section 1, Paragraph 2.4, refer to Section 5 for proper adjustment procedures.

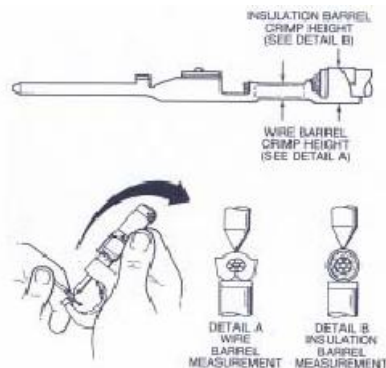



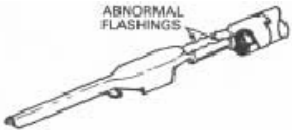

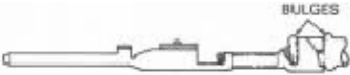

Figure 5. Measuring Crimp Height of Terminal

### 3. TROUBLESHOOTING

The troubleshooting information provided in the following chart will help isolate and identify crimping problems.

Troubleshooting Chart, Male Pin Terminal		
PROBLEM	POSSIBLE CAUSE	CORRECTIVE ACTION
Bellmouth(s) is deformed or improperly positioned on wire barrel. 	Terminal is not properly positioned in crimping area.	Insert terminal so its shoulder is against the terminal holder.  Reposition guide pins until proper bellmouth(s) is achieved.
Pin end of terminal is bent down 	Terminal is sticking in wire barrel crimper.  Tooling is broken or cracked.	Replace wire barrel crimper as described in Section IV, paragraph B.
The sides of the terminal wire barrel are scored or scratched. 	Wire barrel crimper is defective.	Replace wire barrel crimper as described in Section IV paragraph B.
Flashings formed on the bottom of the wire barrel are unequal or abnormal. 	Anvil is worn or broken	Replace anvil as described in Section IV, paragraph A.
Insulation bulges between wire and insulation barrels. 	Wire strip length is incorrect, or wire was inserted too far into the terminal.	Refer to Section I, Paragraph D (specifications) for strip length requirements.
Insulation bulges around insulation barrel 	Wire or insulation diameter is incorrect for the terminal being used.	Refer to section I, paragraph D (specifications) for correct insulation diameter requirements.



## 4. PARTS REPLACEMENT PROCEDURES

### 4.1 Anvil Replacement

Replace anvils when they show excessive wear or become cracked or chipped.

#### Removal

1. Remove the cap screw securing the anvil holder assembly to the hand tool (see Figure 6) and then remove the anvil holder assembly.

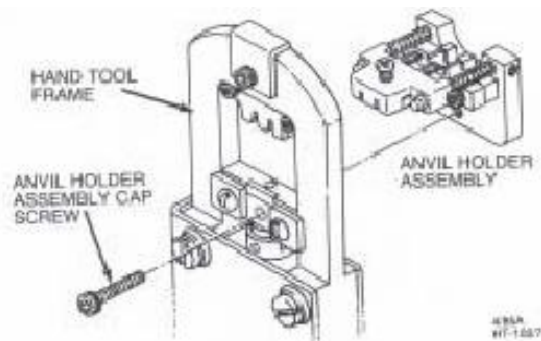

Figure 6

2. Loosen the two setscrews in the anvil holder and remove the terminal holder (see Figure 7).

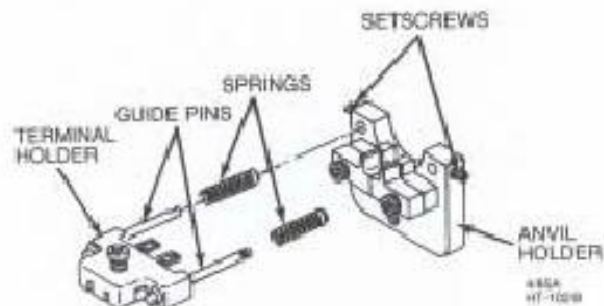

Figure 7

3. Remove the cap screw and defective anvil(s) from the anvil holder (see Figure 8).

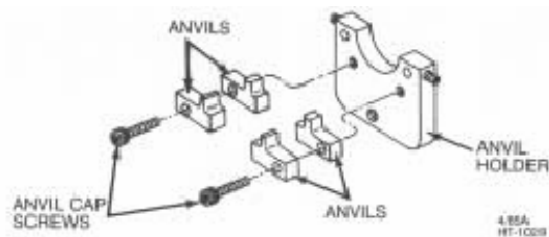

Figure 8

## Installation

### NOTE

When replacing the anvils, be sure that the part number for the new anvil(s) is the same as the one being replaced.

1. Loosely install the new anvils to the anvil holder with the attaching cap screw (See Figure 8).
2. Reinstall the anvil holder onto the hand tool and tighten the attaching cap screw.

### CAUTION

To prevent the anvils from being damaged during alignment, place a piece of paper over the anvils.

3. Cut out two strips of paper. Then fold the strips in half and place them over the anvils (see Figure 9).

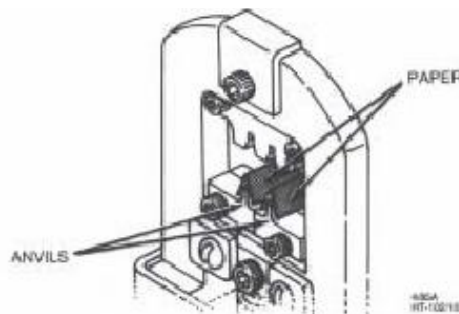

Figure 9

4. Slowly close the hand tool lever completely. This will align the anvils to the crimpers. Then tighten the anvil cap screw and release the lever. Next, remove the paper from the anvils.
5. Reinstall the terminal holder to the anvil holder. Make sure that the flats on the end of the terminal holder guide pins face the setscrews in the anvil holder. Then tighten the anvil holder set screws.
6. Crimp a terminal to the proper size wire. Then inspect the terminal as described in section II, paragraph B.

## 4.2 Wire and Insulation Barrel Crimpers and Tonker Replacement (see Figure 13)

### Removal

1. Loosen, but do not remove at this time, the two cap screws (7) that secure the crimpers to the crimper holder (1).
2. Remove the cap screw (9) from the crimper holder (1).  
Then remove the spring retainer (8) and the crimper holder (1) with crimpers attached.
3. Remove the two tonker springs (5) and the two spring guides (6) from the hand tool frame.  
This can be accomplished by tilting the hand tool down.
4. Remove the two cap screws (7) that secure the crimpers to the crimper holder (1).
5. Remove the crimpers (3 and 4) and tonkers (2) from the crimper holder (1).
6. Remove the damaged crimper(s) (3) or (4). The top crimper is the wire barrel crimper (4).

### Installation

#### NOTE

When replacing tooling, always be sure that the part number of the new part is the same number that is on the old part that was removed

7. Place the insulation crimper (3) onto the flat side of the crimper holder (1). Place the wire barrel crimper (4) on the insulation crimper (3) and loosely install the two attaching cap screws.
8. Insert tonkers (2), with the top tabs facing outwards, into the slots between the wire and insulation crimpers.
9. Place and hold the crimper assembly into the hand tool with crimper holder (1) on the same side as the anvil holder (11).  
Make sure that the tonkers (2) go into the holes in the top of the hand tool frame.
10. Place spring guides (6) into the holes in top of the hand tool frame, then insert the springs (5) into the holes so that the springs slip over the body of the spring guides.
11. Place spring retainer (8) over tonker springs (5). Make sure springs are compressed, then loosely attach the spring retainer (8) and the crimper holder (1) to the hand tool with the attaching cap screw (9).
12. To align the tooling, close hand tool completely and hold it in its closed position. Tighten the two cap screws (7) to secure the crimpers to their holder. Then tighten the cap screw (9), which secures the crimper holder to the hand tool frame.
13. Crimp a terminal to a proper-size wire and inspect the terminal as described in Section II, paragraph B.

## 5. ADJUSTMENT PROCEDURES

### 5.1 Crimp Height Adjustment

1. Remove the cap screw securing the anvil holder assembly to the hand tool (see Figure 10). Then remove the anvil holder assembly.

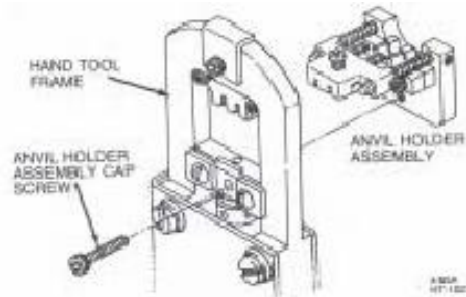

Figure 10

2. Insert a 3/32-inch Allen wrench into the hole in the adjustable tool holder and into the socket head setscrew (see Figure 11). Turn the setscrew ¼ turn counter clockwise to unlock the adjusting collar.

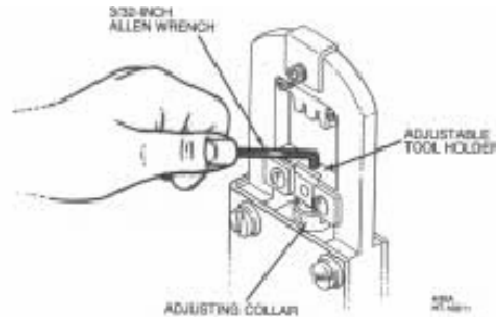

Figure 11

3. Close the hand tool lever one click to gain access to the holes in the side of the adjusting collar. Next, insert a pin approximately 1/16-inch in diameter, into one of the holes in the collar (see Figure 12). Then rotate the collar about 5 degrees counterclockwise to increase crimp height or clockwise to decrease crimp height.

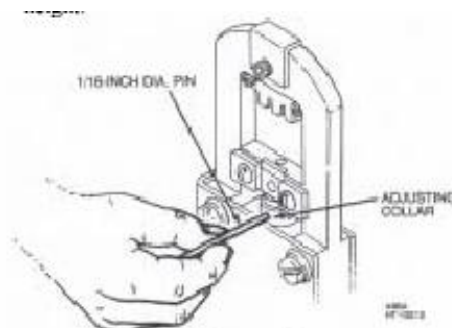

Figure 12

4. Reinstall the anvil holder assembly onto the hand tool and tighten the attaching cap screw.
5. Crimp a terminal to the proper size wire and check the wire barrel crimp height of the crimped terminal. If crimp height is not as specified, remove the anvil holder assembly and turn the adjusting collar an additional 5 degrees. Then reinstall the anvil holder assembly and again check the crimp height. Continue adjusting the crimp height in this manner until the proper crimp height is achieved.
6. Remove the anvil holder assembly and tighten the setscrew clockwise in the adjustable tool holder. Then reinstall the anvil holder assembly and tighten the attaching cap screw.

## **6. PARTS**

### **6.1 Spare Parts**

These are parts that Föhrenbach Application Tooling considers practical for the user to stock for replacement. Recommended spare parts for the hand tool are specified in bold type in the parts list for Figure 13.

### **6.2 Parts Ordering Information**

To obtain replacement parts, contact Föhrenbach Application Tooling.

### **6.3 Hand Tool Repair Policy**

Föhrenbach Application Tooling charges a standard rate to repair any hand tool not under warranty. Föhrenbach Application Tooling will repair the hand tool and return it to you by the fastest means possible.

Parts List for Figure 13, HT-0119 Hand Tool Parts

Index no.	Part No.	Description	Quantity
1	A-857-5	CRIMPER HOLDER	1
<b>2*</b>	<b>104964-1</b>	<b>TONKER</b>	<b>2</b>
<b>3*</b>	<b>415601-001</b>	<b>INSULATION BARREL CRIMPER 22-26 GAUGE WIRE</b>	<b>1</b>
<b>4*</b>	<b>415602-001</b>	<b>WIRE BARREL CRIMPER 22-26 GAUGE WIRE</b>	<b>1</b>
5	A-1153	TONKER SPRING	2
6	A-1155	GUIDE SPRING	2
7	915305-224	SHCS, 4-40 NF X .. LONG	8
8	104963-1	SPRING RETAINER	1
9	915305-205	SHCS, 6-40 NF X ½. LONG	2
10	915305-559	SHSS(SET SCREW) 2-56 NC X 1/8. LONG	2
11	102466-1	ANVIL HOLDER	1
<b>13*</b>	<b>108178-002</b>	<b>INSULATION BARREL ANVIL, 22-26 G WIRE</b>	<b>1</b>
<b>15*</b>	<b>108177-002</b>	<b>WIRE BARREL ANVIL, 22-26 G WIRE</b>	<b>1</b>
16	102470-1	TERMINAL HOLDER SPRING, 0.65. LONG	2
17	147070-1	TERMINAL HOLDER	1
18	900066-001	O-RING, 0.070. I.D., 01-004	2
19	102468-2	GUIDE PIN	2
20	144547-001	GUIDE RAIL	2
21	147071-1	TERMINAL CLAMP	1
22	147072-1	QUILL PUNCH	1
23	102470-2	PUNCH SPRING, 0.300. LONG	1
24	150564-1	COLLAR. NYLON_, PRESS-FIT, 0.0625. I.D.	1

\*Recommended Spare Parts

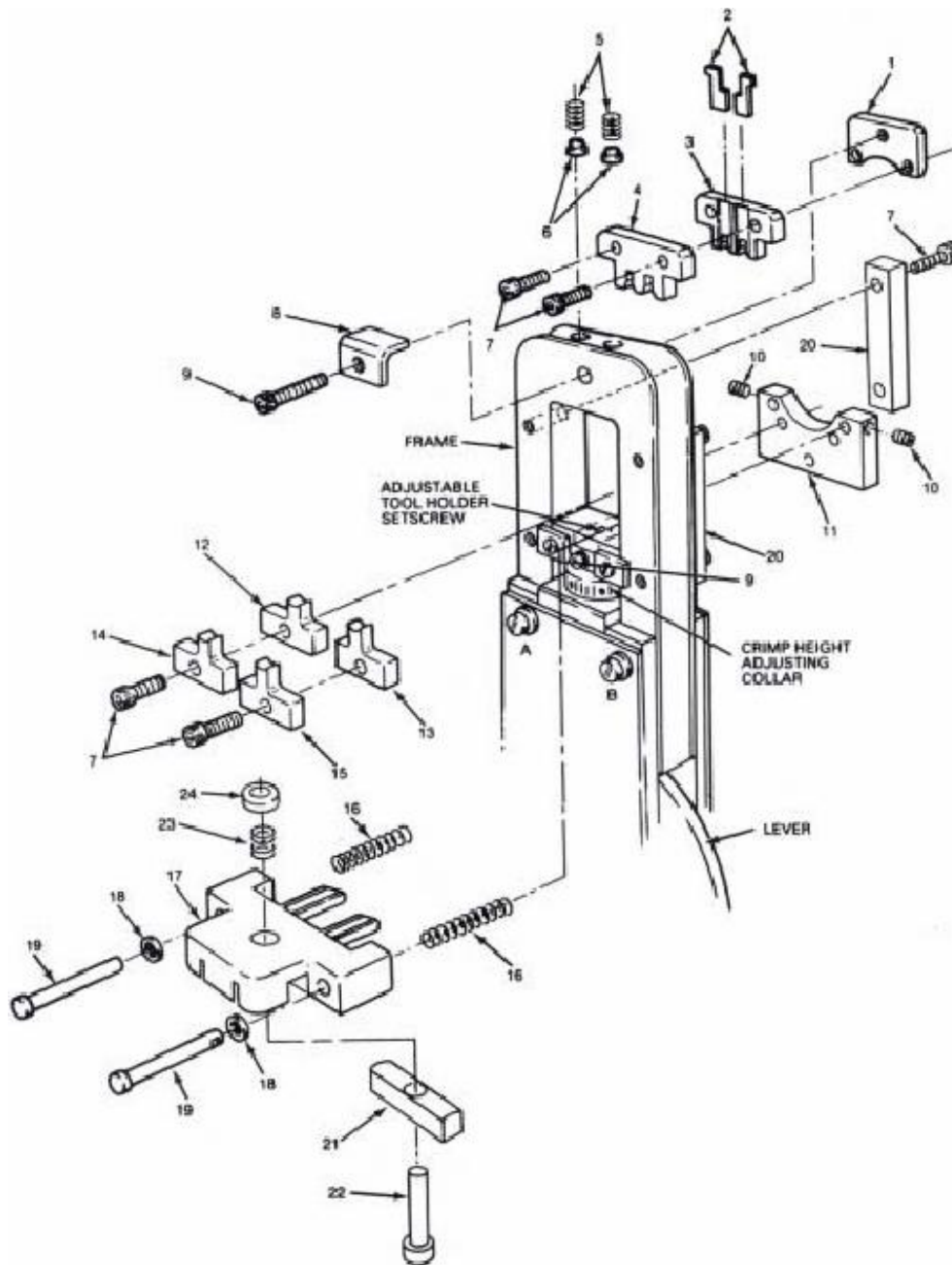

Figure 13. HT-0102 Hand Tool Parts

The technical data in this publication has been carefully checked and assembled. No liability from inaccuracies or errors is assumed. The right to change or improve this document without notice is reserved.