

LAVINA®



LAVINA® 13-S User Manual



 **SUPERABRASIVE**

Tech Support Line: 800-987-8403 | www.superabrasive.com | info@superabrasive.us

1. GENERAL INFORMATION	3
Manufacturer.....	3
General Description	3
Machine characteristics	3
MAIN DESIGN.....	3
Environmental Conditions	3
Electrical Connection	3
Vacuum Connection.....	4
Technical Data	4
Vibrations	Error! Bookmark not defined.
Sonorous Emissions	Error! Bookmark not defined.
Label Data.....	Error! Bookmark not defined.
Customer Service	Error! Bookmark not defined.
2. SAFETY INSTRUCTION	5
Recommended Use.....	5
Prohibited Use	5
Preparation for work	5
Protection Devices	5
Arrest Functions.....	5
Safe Use	5
Residual Risks	5
Before You Begin	5
Operating Machine	5
After Work is completed.....	5
The Work Area.....	5
PERSONAL PROTECTIVE Equipment (ppe).....	5
Operator	6
3. OPERATION	6
Preliminary Controls	6
Mounting Tools.....	6
leveling after mounting the tool	6
Adjusting handle	7
Tool protecting guard	7
the Control Board	8
Starting the Machine	8
Operating the Machine	8
Stopping the Machine.....	8
4. TOOLS AND ACCESSORIES	9
WEIGHTS.....	9
Tool holder key	9
Foam Plate	9
Security plate for Quickchange pads.....	9
5. POPULAR TOOLS	10
RECOMMENDED TOOLS	10
6. EXPLODED VIEW	11

General Exploded View (Fig.6.1).....	11
Main Head Disassembly 1 (Fig.6.2).....	11
Main Head Disassembly 2 (Fig.6.3).....	11
Carriage Disassembly (Fig.6.4).....	11
Option for water (Fig.6.5).....	11

7. MAINTENANCE AND INSPECTION.....12

Cleaning	12
Check Daily.....	12
Check and replace after the first 15 Working Hours	12
Check Every 200 Working Hours.....	12
Check Every 500 Working Hours.....	12
Vacuum	12
Mechanical Parts.....	12
Electrical System	12
ONE phase connection	12
Lavina® 13-S Electrical schemes with YASKAWA Inverter 200-240 Volt	13
LAVINA® 13-S ELECTRICAL SCHEMES YASKAWA CONNECTION MAIN CIRCUIT TERMINALS	13

8. TROUBLESHOOTING.....14

Index of Problems and Solutions	14
8.1 Replacing Power Cord and Plugs	14
8.2 DISMOUNTING AND MOUNTING TOOL HOLDER TO CHANGE BUFFERS AND SPIDER, CHANGING V-RINGS AND FELT-RINGS	14
8.3 TENSIONING THE BELTS	15
8.4 Changing the belt	15
8.5 Motor connection.....	16
8.6 Fault diagnosis Inverter YASKAWA V1000	17

9. WARRANTY AND RETURNS.....20

Warranty Policy for Lavina®13-S	20
RETURN POLICY FOR LAVINA®13-S.....	20

10. DISPOSAL.....20

11. MANUFACTURER'S CONTACTS.....20

12. SPARE PARTS.....21

ASSEMBLY AND PARTS SPECIFICATIONS.....	21
1. LAVINA®13-S General Parts	21
2. LAVINA®13-S Main Head 1.....	21
3. LAVINA®13-S Main Head 2.....	22
4. LAVINA®13-S Tool Holder Parts	22
5. LAVINA®13-S option for Water	22
7. CONTROL BOX PARTS 200-240 Volt	24
7. LAVINA® 13-S CONTROL BOX PARTS 200-240 Volt.....	24

1. GENERAL INFORMATION

This owner's manual is intended for the operator of the Lavina® 13-S machine, the servicing technician as well as for anyone involved with operating or servicing the machine. We recommend that you read the instructions very carefully and follow them strictly. The manual includes information about assembling, using, handling, adjusting and maintaining your Lavina® 13-S floor grinding and polishing machine.

MANUFACTURER

Superabrasive was founded in 1987, as a manufacturer of high quality diamond tools for the stone and concrete industry. Today, Superabrasive is one of the world's leading companies in the production of diamond tools and floor grinding machinery. At Superabrasive, we strive to deliver the very best solutions to our customers, and enable them to work more efficiently.

GENERAL DESCRIPTION

The Lavina® 13-S machine is intended for grinding, polishing and buffing concrete, marble, granite, limestone and terrazzo surfaces with diamond tools.

The Lavina® 13-S is a one-disc machine.

The Lavina® 13-S is intended to grind/polish edges, corners, steps of stairs or difficult to reach surfaces. Additionally, the machine could be used for grinding wood floor surfaces.

For best results, use only tools manufactured or recommended by Superabrasive and its distributors.

⚠ WARNING The Lavina®13-S machine is manufactured and fitted for the above-mentioned applications only! Every other use may possess risks to the persons involved.

MACHINE CHARACTERISTICS

The Lavina®13-S is made so it can grind/polish surfaces, where bigger machines have difficulties to reach.

MAIN DESIGN



Figure 1.1



Figure 1.2



Figure 1.3

Main Head has 3 fixed working positions – forward, left 45° and right 45° for working close to walls.

The inclination of the main head is adjusted crosswise and lengthwise to 4° (Fig. 1.1)

The halogen spotlight (Fig.1.2) enables the operator to work in darker areas.

⚠ WARNING

Existing lighting system does not replace adequate overhead lighting.

The frame The handle on the frame is adjustable in height and allows the operator to work in a correct and safe posture.

The electrical box (fig.1.3) contains the electric switching devices and the inverter. The motor feeding cable is on the bottom part of the unit. The **main feeding cable** is connected with a plug and socket on top

The motor is mounted on the base plate. The motor is driving the grinding head with a belt system.

ENVIRONMENTAL CONDITIONS

The temperature range for operating the Lavina®13-S outdoors is between 41°F and 86°F or 5°C and 30°C. Never use the Lavina®13-S during rain or snow when working outdoors. When working indoors, always operate the machine in well-ventilated areas.

ELECTRICAL CONNECTION

The voltage (Volt) and power (Ampere) are displayed on a label on the electrical control box to avoid any incorrect connection. Refer to these before connecting the power. To avoid electrical shocks, make sure the ground power supply is functioning properly.

VACUUM CONNECTION

A connection for a vacuum dust extractor is located on the handle. The Lavina®13-S does not include a vacuum dust extractor. The customer must purchase the vacuum dust extractor separately. The hose of the vacuum extractor must be Ø 50.8 mm and can be glided over the pipe. The vacuum dust extractor must be adapted for floor grinders and have a minimum air displacement of 300m³/h with a negative vacuum of 21 kPa.

TECHNICAL DATA

Lavina® 13 - S	
Voltage/Hz	1 ph x 200-240 V 50/60Hz
Amperage	Max 12 Amps
Power	2.2 kW 3 hp
Tool holder rpm	500-800 rpm
Working width	335 mm 13,2"
Tool holder diameter	335 mm 13,2"
Tool diameter	335 mm 13,2"
Weight	115 kg 253,5 lbs
Grinding pressure	26 kg 57 lbs
Additional weight	max 4x2,5 kg 22 lbs
Application	dry
Vacuum hose port	yes
Option for water	
- Water tank capacity	20l 5.2gal
-Water feed	with pump front
Cable length	17.4 m 57 ft
Machine LxWxH	1208x599.5x917 mm 47.6"x23.6" x36.1"
Packing LxWxH	1410x730x1100 mm 55.5"x28,7"x43.3"

Vibrations

The vibrations of the machine are within the limits of directives and harmonized standards from the European Union when the Lavina®13- S is operated with the recommended tools and in normal conditions.

Sonorous Emissions

The sonorous emissions are within the limits of directives and harmonized standards from the European Union when the Lavina® S is operated with the recommended tools and in normal conditions. However, as previously stated, the operator must wear ear protectors.

Label Data

The data on the label provides the correct Voltage and kW (needed for operational purposes); Weight (needed for transportation purposes); production year and serial number (needed for maintenance purposes).

Customer Service

For customer assistance and technical support call your local distributor or call Superabrasive Inc. at 1-800-987-8403 or visit us at: www.superabrasive.com , where you can download a copy of this manual.

2. SAFETY INSTRUCTION

RECOMMENDED USE



WARNING

The Lavina®13-S machine is designed and manufactured to grind and polish concrete, terrazzo and natural stone floors. It can be used for renovations as well as for polishing. The machine is designed for dry use. Use a vacuum of appropriate size. For more information, please refer to the chapter on handling the vacuum connection.

PROHIBITED USE



WARNING

The machine MUST NOT be used:

For applications different from the ones stated in the General Description chapter.

For not-suitable materials.

In environments which:

Possess risks of explosion

Possess high concentration of powders or oil substances in the air

Possess risks of fire

Feature inclement conditions.

Possess electromagnetic radiation.

PREPARATION FOR WORK



WARNING

Make sure that:

You have closed the work area, so that no person unfamiliar with operating the machine can enter the area

The tool plate and tools are adjusted to the machine properly

There are no missing parts of the machine

The machine is in upright working position

The protection devices are working properly.

The electrical cable is free to move and follow the machine easily. In order to keep the electrical cable from being damaged, no vehicle should cross the zone where electrical cables are situated.

PROTECTION DEVICES



WARNING

The machine is equipped with several protection devices including the following:

An emergency stop button

A protection skirt and a hood for protecting the tool plates.

These devices protect the operator and/or others persons from potential injuries. Do not remove them. On contrary, before using the machine, please ensure that all protection devices are mounted and function properly.

ARREST FUNCTIONS



WARNING

Functions of arresting of the machine are following:

Button to stop the motor (category 1)

Emergency button (category 1)

SAFE USE



WARNING

The Lavina®13-S is designed to eliminate all risks correlated with its use. However, it is not possible to eliminate the risks of an eventual accident with the machine. Unskilled or

uninstructed operator may cause correlated residual risks. Such risks are:

Position Risks due to operator's incorrect working position

Tangling up Risks due to wearing inappropriate working clothes

Training Risks due to lack of operational training

NOTE: In order to reduce all consequences of the above-mentioned risks, we advise that machine operators will follow the instructions in the manual at all times.

RESIDUAL RISKS



WARNING

During the normal operating and maintenance cycles, the operator is exposed to few residual risks, which cannot be eliminated due to the nature of the operations.

BEFORE YOU BEGIN



WARNING

Working area must be clear from any debris or objects.

A first-time operator must always read the manual and pay attention to all safety instructions.

All electric connections and cables must be inspected for potential damages.

Ground wire system of the power supply must be also inspected.

Perform general daily inspections of the machine and inspect the machine before each use.

Always inspect the safety devices:

The emergency break must be clear and working

The tool protector must be working

The machine must be clean

Never operate the machine in the rain!

Confirm that there are no missing parts especially after transportation, repair or maintenance.

OPERATING MACHINE



WARNING

When operating the Lavina®13-S, make certain that there is no one, but you around the machine.

Never leave the machine unattended while working.

The electrical cable must move freely and must be damage-free.

Check if the floor, you work on, is not too uneven. If this is the case, it may damage the machine.

AFTER WORK IS COMPLETED



WARNING

Clean the machine and its surroundings properly

Unplug the machine and wind up the electrical cable

Store the machine in a safe place

THE WORK AREA



WARNING

Make certain that people or vehicles do not enter the work area.

Avoid cables and hoses being in the way.

Always check the floor for debris

PERSONAL PROTECTIVE EQUIPMENT (PPE)



WARNING

Always wear safety shoes when working with the machine.

Always wear ear protectors when working with the machine.

All personnel in the immediate work area must wear safety glasses with side shields.

Always wear safety gloves when changing the tools.

Always wear clothes suitable for the work environment.

OPERATOR

The Lavina®13-S machine.

The operator must know the machine's work environment.

Only one operator at a time can work with the machine.

The operator must be properly trained and well instructed prior operating the machine.



The operator must understand all the instructions in this manual.

The operator must understand and interpret all the drawings and designs in manual.

The operator must know all sanitation and safety regulations pertaining to the operation of

The operator must have floor grinding experience.

The operator must know what to do in case of emergency.

The operator must have an adequate technical knowledge and preparation.

3. OPERATION

PRELIMINARY CONTROLS

Inspect the working area as explained in the safety instructions. For dry use connect the vacuum extractor and ensure that the vacuum hose is clear and it will follow the machine easily. Plug in the machine and make sure that the power cord is free to follow the working direction of the Lavina®13-S.



Figure 3.1



Figure 3.2



Figure 3.3

MOUNTING TOOLS

Mount the tools only after ensuring that there is enough diamond bond material left. Be sure that the plates are always clean before mounting. **WARNING:** Secure always the "Quickchange" pads with the security plate (Fig.3.1), lock with the tool holder key (Fig.3.2). Diamond tools with Velcro are attached on foam plate of 13,2 inch (Fig.3.3). The foam plates are mounted on the key lock (butterfly). Always use the tool holder key (Fig.3.3).

LEVELING AFTER MOUNTING THE TOOL

On top of the base plate is mounted a water level (Fig. 3.4). Designed to establish the good working position of the tools and adjusted by the operator in the different ranges:

Turn left and right on 45° by releasing the screw handle (Fig. 3.4)



Figure 3.4



Figure 3.5



Figure 3.6

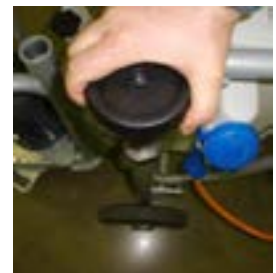

Figure 3.7

Tilt crosswise to the left and to the right to 4° - release the screw handle (Fig. 3.5)

Using the handle (Fig 3.6) and guided by the index line and the levelling put the operating part in the desired crosswise position and screw the handle (Fig 3.5)

Using the vertical screw (Fig 3.7) and guided by the leveling adjust the operating part to flat position or find the required lengthwise tilt (forward or backward).

ADJUSTING HANDLE



Figure 3.8



Figure 3.9



Figure 3.10

Unscrew the handle (Fig. 3.8) till it reaches the ager (Fig. 3.9). Pull up the ager (Fig. 3.9) and turn the handle to the desired position. Find the position where it goes down and screw the handle. (Fig. 3.10).

TOOL PROTECTING GUARD

The protecting guard has free movement and is self-adjusting according to the height of the tool abrasion and is turning in the range of 45° clockwise or anti clockwise following the wall (Fig 3.11). The height of the brush is adjusted only when using the Foam plate (Fig.4.3). The adjustment is made by unscrewing the bolts on the side of the guard (Fig 3.12) and pulling out the brush to the desired position.

The plastic rolls on the protecting guard serve to protect the wall from damages (Figure 3.11). By moving the roll in the hole (Figure 3.13) can be adjusted the distance of the working tool to the wall.



Figure 3.11



Figure 3.12



Figure 3.13

THE CONTROL BOARD

1. **Digital RPM indicator** Indicates the revolution per minute of the grinding plates (not the revolution per minute of the entire unit).
2. **Reset button** resets the alarm of the inverter
3. **Power led** lights green when the power is on
4. **Forward/Reverse switch** choose forward for clockwise rotation of the grinding plates or reverse for anti-clockwise rotation of the grinding plates
5. **Potentiometer** changes the RPM of the grinding plates from 300-800 rpm
6. **OFF button** stops motor
7. **ON button** starts motor
8. **Emergency button** used in Emergency situations for stopping the motor



Figure 3.14

STARTING THE MACHINE

First, follow the directions in chapter Safety Devices and Safety Instructions. Next, pull the emergency stop (Fig. 3.14 8) to ensure that the machine is in working condition. Check the potentiometer (Fig. 3.14 5) and ensure that it is set at the working speed. Switch on the vacuum unit. Finally, hold the machine firmly and push the start button (Fig. 3.14 7).

OPERATING THE MACHINE

Work at a constant speed allowing the tools time to work at a speed appropriate for the tools' grit size. Avoid vibrations. Do not stop the Lavina®13-S machine in one spot while the tools are still working because they will leave marks on the floor surface. Check the floor surface periodically to ensure that dust is not accumulating on the surface, also check regularly if your vacuum works properly.

In case you use Lavina®13-S as one disc machine for floor maintenance guide the machine in straight lines across the floor, and with each new line overlap a little bit of the previously completed surface.

STOPPING THE MACHINE

The stopping of the machine must be done gradually until the motor stops. Do not stop moving the machine before arresting the motor as the tools could damage the surface. Switch off with the off button (Fig. 3.14 6). Use the Emergency button (Fig. 3.14 8) only in emergency or use it to switch the power totally off.

Remember not to hold the machine in one spot before turning off the motor.

4. TOOLS AND ACCESSORIES

WEIGHTS

Superabrasive offers additional weights for increasing the productivity of the machine (Fig.4.1). Each additional weight weighs about 5.5 lbs or 2,5 kg. Each individual application, type and condition of surface, power capacity of the outlet, etc. will determine the number of weights you can use without tripping a breaker, Although wit a maximum of four. The weight stacks on to central shaft above the toolts around the outer bowl (Fig.4.1).

The additional weight depends on the tools; it is not always possible to add weights. Some tools work too aggressively and the machine can stop.



Figure 4.1



Figure 4.2

TOOL HOLDER KEY

The tool holder key (Fig.4.2) is used for adjusting, mounting and dismounting of the foam plates. Always use the key for mounting.

Item number is A03.00.00.00

FOAM PLATE

Diamond tools with Velcro are mounted on the foam plate 13.5“(Fig.4.3).

The foam plate is mounted on the “QuickChange”System.

Item number is LV-FP-13.5-S

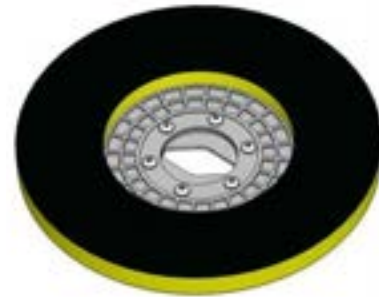

Figure 4.3

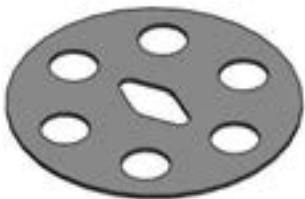

Figure 4.4

SECURITY PLATE FOR QUICKCHANGE PADS

Plate (Fig.4.4) used to ensure the “Quickchange” pads.

Item number is A38.00.02

5. POPULAR TOOLS

RECOMMENDED TOOLS



QuickChange System and Tooling feature extremely fast and convenient tool changes, and a long tool life, providing for great long-term cost savings. The QuickChange pads are produced in four different bonds for super hard, hard, medium and soft concrete, in a variety of grit sizes, with either 1 or 2 buttons, which allows you to customize the aggressiveness of the cut.

Calibra grinding discs: our popular ceramic bond discs are designed for the removal of difficult scratches and they save you valuable time by eliminating the need for multiple passes with metal tools. They can be used wet or dry, and are best for hard concrete applications. They are with Velcro attachment.



NATO® polishing discs feature a special resin formula designed for both wet and dry applications and a unique design with wide channels allowing for work on a cleaner surface and ensuring a quality polish. Available in 3 and 4 in sizes. They are with Velcro attachment.

V-HARR® Premium Polishing Pads are designed for mechanically polishing and restoring concrete; also ideal for terrazzo and hard stone floors. V-HARR® pads are offered in a wide variety of diameters and grit sizes to accommodate many applications. Dry use is strongly recommended.

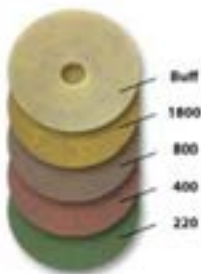

Shine Pro® are high quality diamond-impregnated pads for floor maintenance. Available in a variety of sizes, they are designed for use under swing machines and burnishers, and are great for daily use – they require only water (no wax or chemicals needed) and are a very environmentally friendly solution for maintaining floors.

Use only Superabrasive’s recommended tools see www.superabrasive.com

6. EXPLODED VIEW

GENERAL EXPLODED VIEW (FIG.6.1)

MAIN HEAD DISASSEMBLY 1 (FIG.6.2)

MAIN HEAD DISASSEMBLY 2 (FIG.6.3)

CARRIAGE DISASSEMBLY (FIG.6.4)

OPTION FOR WATER (FIG.6.5)

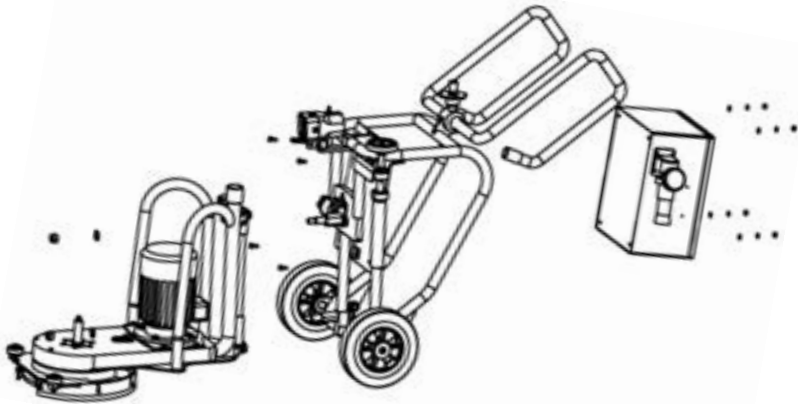

Figure 6.1



Figure 6.2

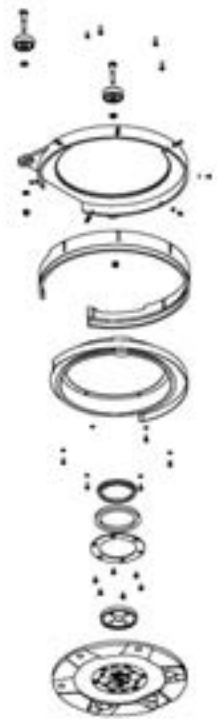

Figure 6.3

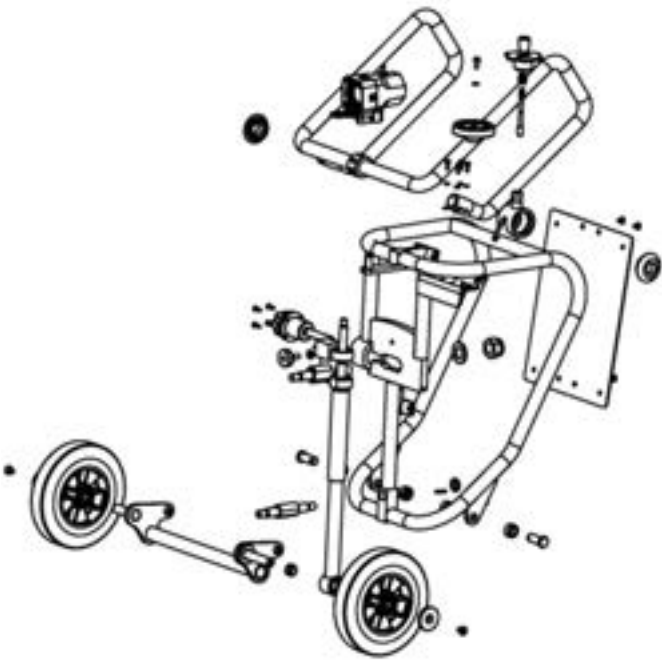

Figure 6.4

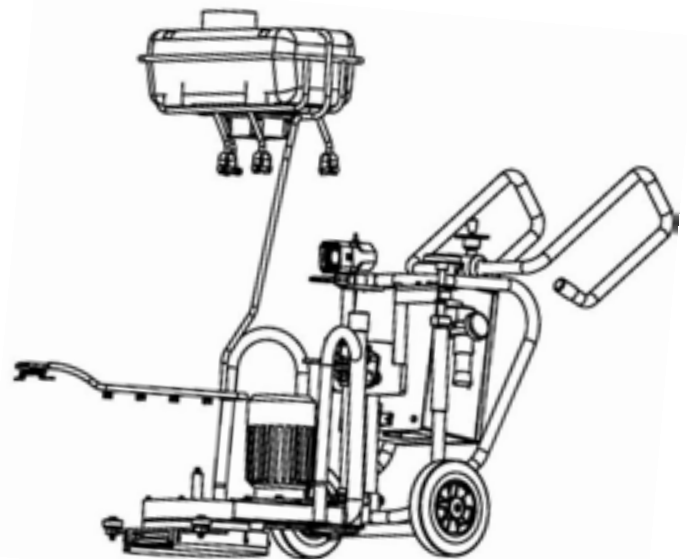

Figure 6.5

7. MAINTENANCE AND INSPECTION

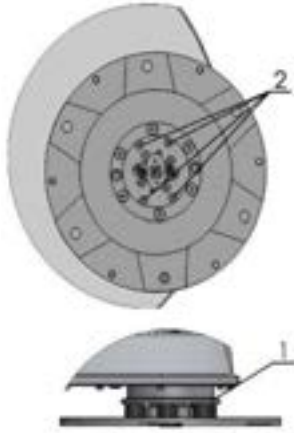

Figure 7.1

CLEANING

Keep your machine clean. Cleaning the machine on a regular basis will help detect and solve potential problems before they cause damage to the machine. Most importantly, check and clean the tool plate connections, power cord and plugs, vacuum hoses.

CHECK DAILY

After operating the Lavina®13-S machine, the operator should conduct a visual inspection of the machine. Any defect should be solved immediately. Pay attention to power cords, plugs and vacuum hoses, loose bolt or screws.

Tool holders: Buffers and spiders are consumables and must be visually checked daily and replaced if needed. See flanges or discs are mounted locked well in place The key lock holders (butterflies) should be also checked.

Check the rubber buffers and fixing of the holders. The flange holding the buffers (Fig.7.1 1) has to be firmly fixed to the unit. A gap seen there means that there are loose screws fixing the holder. The screws has to be tightened immediately for safety operation.

Working with loose screws on the holder could also cause bad damages on the machine. Tightening force of the screws has to be 25...30N.m(18...22 ft/lbs).

It is very important to check regularly the screws(Fig.7.1 2),that fix the "Quickchange" holder to the safety part, so that holder will not fly away if the buffers got damaged
"Quickchange" should be clean.

CHECK AND REPLACE AFTER THE FIRST 15 WORKING HOURS

Check the belt tension after 15 hours working with the machine.

For the correct tension, see TROUBLESHOOTING.

CHECK EVERY 200 WORKING HOURS

Every 200 working hours, the operator should inspect all parts of the machine carefully. Most importantly, inspect and clean the tool plate connections, power cord and plugs, vacuum. Check the guard assembly. Make certain the wheels are clean and rotate properly. Inspect the control buttons. If there are defective control parts, they should be replaced immediately. Replace worn vacuum- and water hoses. Carefully inspect the seal rings and bearings of the grinding units, and replace any showing signs of excessive wear.

For more information, refer to chapter troubleshooting below.

CHECK EVERY 500 WORKING HOURS

Besides the checks of 200 working hours, open up the bottom cover like described in chapter "TROUBLE SHOOTING REPLACING BELT Check if sealers, belt and bearings are in good condition, change if needed. Beware by tensioning the belt not to "over tension"; the belt will never regain his original tension.

VACUUM

As stated previously, frequently check hoses and other parts for clogging.

MECHANICAL PARTS

Parts such as the belt, seal rings, cap rings, spiders and buffers and guard assembly are subject to wear and should be replaced as needed.

ELECTRICAL SYSTEM

Dust should not enter the control box as it will destroy the contacts.

Remove (blow out) any dust present.

ONE PHASE CONNECTION

Please note: the power cable has 3 wires, one ground is yellow/green the other 2 other colors are "hot" wires and should be connected to the phases. (Fig. 7.2)



Figure 7.2

LAVINA® 13-S ELECTRICAL SCHEMES WITH YASKAWA INVERTER 200-240 VOLT

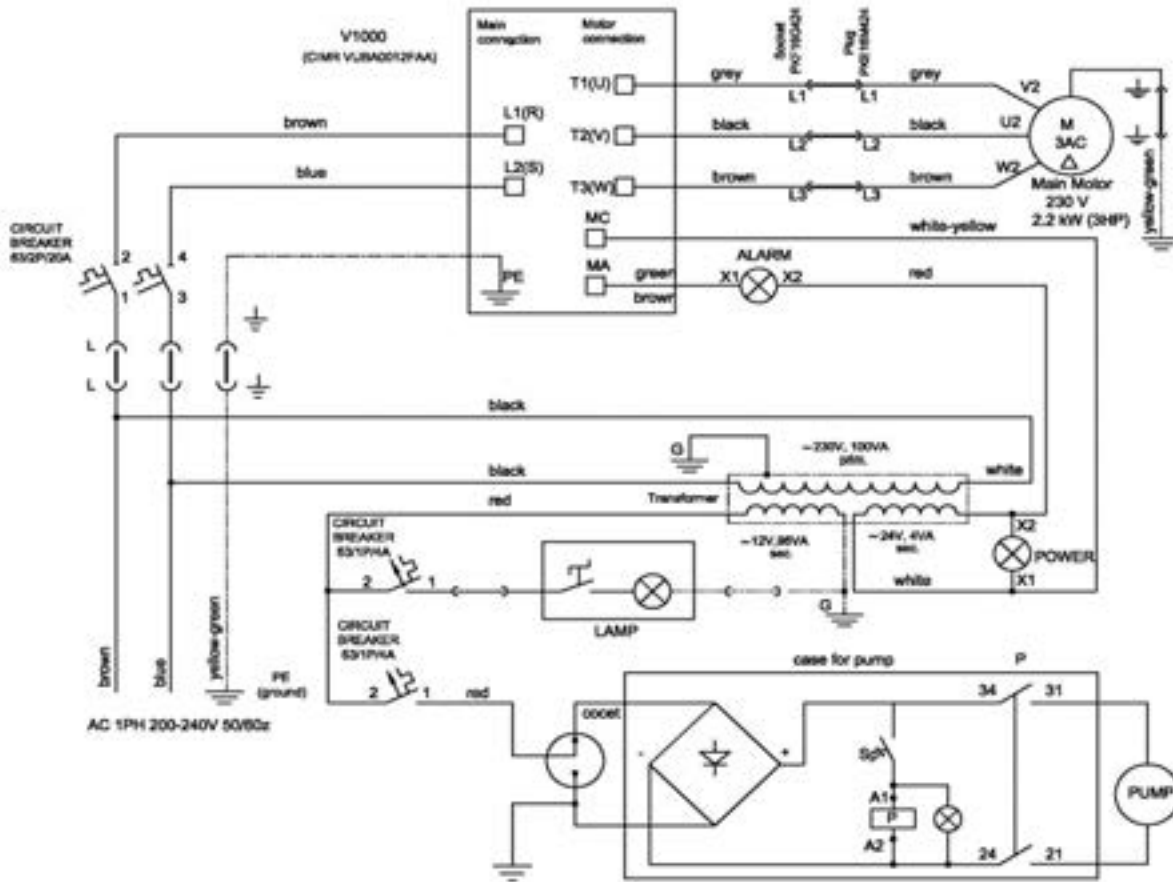
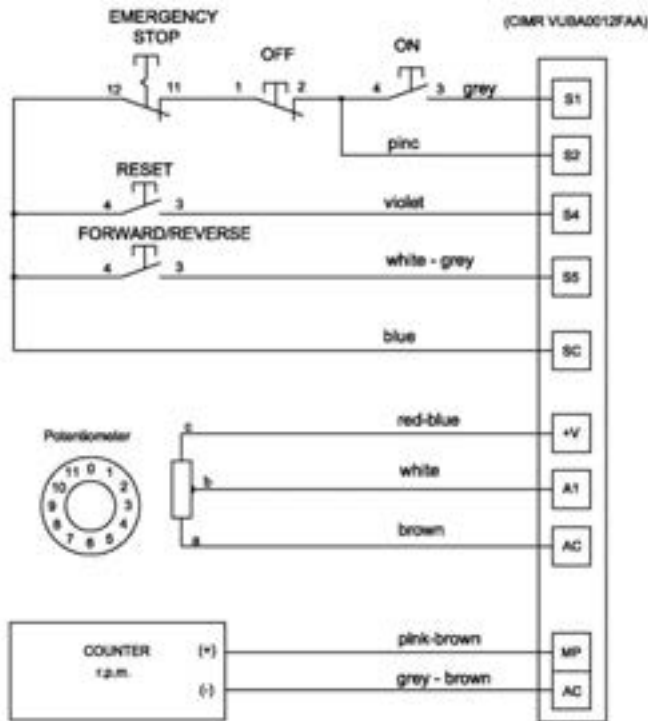

Figure 7.3



LAVINA® 13-S ELECTRICAL SCHEMES YASKAWA CONNECTION MAIN CIRCUIT TERMINALS

The motor is connected in “Delta” (triangle) 230 Volt, reminder for the wire connection of the motor

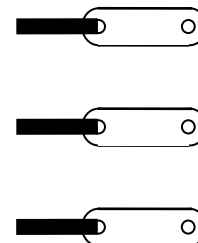

Figure 7.4

8. TROUBLESHOOTING

INDEX OF PROBLEMS AND SOLUTIONS

8.1 REPLACING POWER CORD AND PLUGS

When replacing the power cord or plugs always use cords and plugs with specifications as the original ones. Never use lower quality or different type cord and plugs.

8.2 DISMOUNTING AND MOUNTING TOOL HOLDER TO CHANGE BUFFERS AND SPIDER, CHANGING V-RINGS AND FELT-RINGS



Figure 8.2.1



Figure 8.2.2



Figure 8.2.3



Figure 8.2.4



Figure 8.2.5



Figure 8.2.6

To check or replace the buffers and the spiders, the tool holder have to be dismantled. Remove the countersunk screws on top of the buffer (Fig.8.2.1). Take the disc off (Fig.8.2.2), the spider can be removed or replaced (Fig.8.2.3). By loosening four Hex cap bolts (Fig.8.2.4), the disc comes loose (Fig.8.2.5) and the buffers can be replaced (Fig.8.2.6). Attention, by mounting use always the "blue" thread locking adhesive, except on the bolts to lock the buffers (Fig.8.2.5). Use always original bolts. Depending on the number (3,4 or 6) of buffers, the holder can be more flexible or rigid.



Figure 8.2.7



Figure 8.2.8



Figure 8.2.9

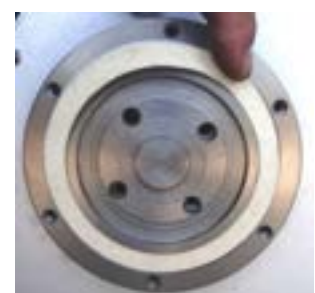

Figure 8.2.10

When the tool holder is dismantled, you can change the sealers (V-Ring and Felt-Ring). Take out Felt-Ring, Adaptor and V-Ring. Before mounting check on which side the adaptor is fitting, remember the correct side. Mount the V-Ring with the smallest lip of the V to inside (Fig.8.2.7) just push the V-ring so the top is on the same level as the pulley top (Fig.8.2.8). Then take the adaptor in the correct way and push the V-Ring down with the adaptor (Fig.8.2.9). The lowest lip of the V-Ring should only barely touch its gliding surface; also never push the V-Ring down with fingers. Mount now the Felt-ring on top (Fig.8.2.10). Close the sealers with the cap (Fig.8.2.11).



Figure 8.2.11

8.3 TENSIONING THE BELTS

PLEASE MAKE SURE YOU CHECK THE TENSION OF THE BELT AFTER THE FIRST 15 HOURS OF OPERATION

If the operator notices, the grinding spindle is turning irregular or noisy or in the worse case, the grinding spindle does not turn although the motor turns. It is recommended to check the belts.

ATTENTION: NEVER "OVER" TENSION THE BELT, THE BELT WILL BE DESTROYED AND IT WILL NEVER RECOVER ITS ORIGINAL TENSION



Figure 8.3.1



Figure 8.3.2



Figure 8.3.3

Remove the revision cover (Figure 8.3.1) and turn the screw (Figure 8.3.3) clockwise to tight the belt. The tightening force of one belt is 173 N measured by OPTIKRIK 1 (Figure 8.3.2) .

8.4 CHANGING THE BELT



Figure 8.4.1



Figure 8.4.2



Figure 8.4.3



Figure 8.4.4



Figure 8.4.5



Figure 8.4.6



Figure 8.4.7



Figure 8.4.8



Figure 8.4.9



Figure 8.4.10

Loosen the screws on the working plate (Figure 8.4,1) and remove it from the working part (Figure 8.4,2). Release the sucker using the screws on its inside peripheral part (Figure 8.4,3) and remove it along with the removable guard. Remove the flange (Figure 8.4,5), adapter (Figure 8.4,6), felt and rubber seals (Figure 8.4,6) (Figure 8.4,7). Remove the front cover by loosening the screws (Figure 8.4,8) and the revision cover by loosening the screws (Figure 8.4,9). By the tightening bolt (Figure 8.4,10) move the motor forward and release the two belts. Put the new belts and tighten them. The Static Belt Tension should be 225 N with a new belt, only 173 N with a used one. It is recommended to use an OPTIKRIK 1 Tension Gauge. The assembly is made in reverse order.

8.5 MOTOR CONNECTION

In case of changing the motor, please check the cable connection to your motor.

The motor is connected in “Delta” (Triangle) 230 Volt, reminder for the wire connection of the motor.

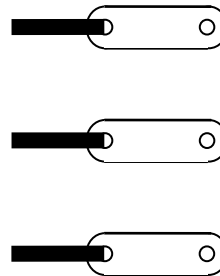

Figure 8.5.1

8.6 FAULT DIAGNOSIS INVERTER YASKAWA V1000

Pages are referring to

Yaskawa Electric SIEP C710606 18A YASKAWA AC Drive – V1000 Technical Manual

◆ Types of Alarms, Faults, and Errors

Check the LED operator for information about possible faults if the drive or motor fails to operate. *Refer to Using the Digital LED Operator on page 70.*

If problems occur that are not covered in this manual, contact the nearest Yaskawa representative with the following information:

- Drive model
- Software version
- Date of purchase
- Description of the problem

Table 6.4 contains descriptions of the various types of alarms, faults, and errors that may occur while operating the drive. Contact Yaskawa in the event of drive failure.

Table 6.4 Types of Alarms, Faults, and Errors

Type	Drive Responses to Alarms, Faults, and Errors
Faults	<p>When the drive detects a fault:</p> <ul style="list-style-type: none"> • The digital operator displays text that indicates the specific fault and the ALM indicator LED remains lit until the fault is reset. • The fault interrupts drive output and the motor coasts to a stop. • Depending on the setting, the drive and motor may stop via different methods than listed. • If a digital output is programmed for fault output (H2-□□ = E), it will close if a fault occurs. • When the drive detects a fault, it will remain inoperable until that fault has been reset. <i>Refer to Fault Reset Methods on page 264.</i>
Minor Faults and Alarms	<p>When the drive detects an alarm or a minor fault:</p> <ul style="list-style-type: none"> • The digital operator displays text that indicates the specific alarm or minor fault and the ALM indicator LED flashes. • The motor does not stop. • One of the multi-function contact outputs closes if set to be tripped by a minor fault (H2-□□ = 10), but not by an alarm. • The digital operator displays text indicating a specific alarm and ALM indicator LED flashes. • Remove the cause of an alarm or minor fault to automatically reset.
Operation Errors	<p>When parameter settings conflict with one another or do not match hardware settings (such as with an option card), it results in an operation error.</p> <p>When the drive detects an operation error:</p> <ul style="list-style-type: none"> • The digital operator displays text that indicates the specific error. • Multi-function contact outputs do not operate. • When the drive detects an operation error, it will not operate the motor until the error has been reset. Correct the settings that caused the operation error to reset.
Tuning Errors	<p>Tuning errors occur while performing Auto-Tuning.</p> <p>When the drive detects a tuning error:</p> <ul style="list-style-type: none"> • The digital operator displays text indicating the specific error. • Multi-function contact outputs do not operate. • Motor coasts to stop. • Remove the cause of the error and repeat the Auto-Tuning process.

◆ Alarm and Error Displays

■ Faults

When the drive detects a fault, the ALM indicator LEDs remain lit without flashing. If the LEDs flash, the drive has detected a minor fault or alarm. *Refer to Minor Faults and Alarms on page 240* for more information. An overvoltage situation trips both faults and minor faults, therefore it is important to note whether the LEDs remain lit or if the LEDs flash.

LED Operator Display	Name	Page	LED Operator Display	Name	Page
bUS	bUS Option Communication Error	242	CPF08	EEPROM Serial Communications Fault	243
CE	MEMOBUS/Modbus Communication Error	242	CPF11	RAM Fault	243
CF	Control Fault	242	CPF12	FLASH Memory Fault	243
CoF	Current Offset Fault	242	CPF13	Watchdog Circuit Exception	243
CPF02	A/D Conversion Error	242	CPF14	Control Circuit Fault	243
CPF03	PWM Data Fault	243	CPF16	Clock Fault	243
CPF06	Drive specification mismatch during Terminal Board or Control Board replacement	243	CPF17	Timing Fault	243
CPF07	Terminal Board Communication Fault	243	CPF18	Control Circuit Fault	243
			CPF19	Control Circuit Fault	244

LED Operator Display	Name	Page
CPF20 or CPF21	RAM Fault	244
	FLASH Memory Fault	244
	Watchdog Circuit Exception	244
	Clock Fault	244
oH3	oH3 Motor Overheat 1 (PTC input)	247
oH4	oH4 Motor Overheat 2 (PTC input)	248
oL1	oL1 Motor Overload	248
oL2	oL2 Drive Overload	248
oL3	oL3 Overtorque Detection 1	249
oL4	oL4 Overtorque Detection 2	249
oL5	oL5 Mechanical Weakening Detection 1	249
oL7	oL7 High Slip Braking oL	249
oPr	oPr Operator Connection Fault	249
CPF22	CPF22 A/D Conversion Error	244
CPF23	CPF23 PWM Feedback Data Fault	244
CPF24	CPF24 Drive Capacity Signal Fault	244
dEv	dEv Excessive Speed Deviation (for Simple V/f with PG)	244
EF0	EF0 Option Card External Fault	244
EF1 to EF7	EF1 to EF7 External Fault (input terminal S1 to S7)	244
FbH	FbH Excessive PID Feedback	245
FbL	FbL PID Feedback Loss	245

LED Operator Display	Name	Page
GF	GF Ground Fault	245
LF	LF Output Phase Loss	245
LF2	LF2 Output Open Phase	246
oC	oC Overcurrent	246
oFR00	oFA00 Option Card Fault (port A)	246
oH	oH Heatsink Overheat	247
oH1	oH1 Heatsink Overheat	247
PGo	PGo PG Disconnect (for Simple V/f with PG)	250
rH	rH Dynamic Braking Resistor	251
rr	rr Dynamic Braking Transistor	251
SEr	SEr Too Many Speed Search Restarts	251
STO	STO Pull-Out Detection	251
UL3	UL3 Undertorque Detection 1	251
UL4	UL4 Undertorque Detection 2	251
UL5	UL5 Mechanical Weakening Detection 2	251
Uv1	Uv1 Undervoltage	252
Uv2	Uv2 Control Power Supply Undervoltage	252
Uv3	Uv3 Soft Charge Circuit Fault	252
oS	oS Overspeed (for Simple V/f with PG)	249
ov	ov Overvoltage	249
PF	PF Input Phase Loss	250

Note: If faults CPF11 through CPF19 occur, the LED operator will display CPF00 or CPF11.

■ Minor Faults and Alarms

When a minor fault or alarm occurs, the ALM LED flashes and the text display shows an alarm code. A fault has occurred if the text remains lit and does not flash. *Refer to Alarm Detection on page 253.* An overvoltage situation, for example, can trigger both faults and minor faults. It is therefore important to note whether the LEDs remain lit or if the LEDs flash.

Table 6.5 Minor Fault and Alarm Displays

LED Operator Display	Name	Minor Fault Output (H2-□□ = 10)	Page
bb	bb Drive Baseblock	No output	253
bUS	bUS Option Card Communications Error	YES	253
CALL	CALL Serial Communication Transmission Error	YES	253
CE	CE MEMOBUS/Modbus Communication Error	YES	253
CrSt	CrSt Can Not Reset	YES	253
dEv	dEv Excessive Speed Deviation (for Simple V/f with PG)	YES	254
dnE	dnE Drive Disabled	YES	254
EF	EF Run Command Input Error	YES	254
EF0	EF0 Option Card External Fault	YES	254
EF1 to EF7	EF1 to EF7 External Fault (input terminal S1 to S7)	YES	255
FbH	FbH Excessive PID Feedback	YES	255
FbL	FbL PID Feedback Loss	YES	255
Hbb	Hbb Safe Disable Signal Input	YES	255
HbbF	HbbF Safe Disable Signal Input	YES	255
SE	SE MEMOBUS/Modbus Test Mode Fault	YES	—
oL5	oL5 Mechanical Weakening Detection 1	YES	249
UL5	UL5 Mechanical Weakening Detection 2	YES	251
dWAL	dWAL DriveWorksEZ Alarm	YES	244
HCR	HCA Current Alarm	YES	256
oH	oH Heatsink Overheat	YES	256
oH2	oH2 Drive Overheat	YES	256
oH3	oH3 Motor Overheat	YES	256
oL3	oL3 Overtorque 1	YES	256
oL4	oL4 Overtorque 2	YES	257
oS	oS Overspeed (for Simple V/f with PG)	YES	257

LED Operator Display		Name	Minor Fault Output (H2-□□ = 10)	Page
<i>ov</i>	ov	Overvoltage	YES	257
<i>PASS</i>	PASS	MEMOBUS/Modbus Test Mode Complete	No output	257
<i>PGo</i>	PGo	PG Disconnect (for Simple V/f with PG)	YES	257
<i>rUn</i>	rUn	During Run 2, Motor Switch Command Input	YES	258
<i>rUnC</i>	rUnC	Run Command Reset	YES	258
<i>UL3</i>	UL3	Undertorque 1	YES	258
<i>UL4</i>	UL4	Undertorque 2	YES	258
<i>Uv</i>	Uv	Undervoltage	YES	258

■ Operation Errors

Table 6.6 Operation Error Displays

LED Operator Display		Name	Page	LED Operator Display		Name	Page
<i>oPE01</i>	oPE01	Drive Unit Setting Error	259	<i>oPE08</i>	oPE08	Parameter Selection Error	260
<i>oPE02</i>	oPE02	Parameter Setting Range Error	259	<i>oPE09</i>	oPE09	PID Control Selection Error	260
<i>oPE03</i>	oPE03	Multi-Function Input Setting Error	259	<i>oPE10</i>	oPE10	V/f Data Setting Error	261
<i>oPE04</i>	oPE04	Terminal Board Mismatch Error	260	<i>oPE11</i>	oPE11	Carrier Frequency Setting Error	261
<i>oPE05</i>	oPE05	Run Command Selection Error	260	<i>oPE13</i>	oPE13	Pulse Train Monitor Selection Error	261
<i>oPE07</i>	oPE07	Multi-Function Analog Input Selection Error	260				

9. WARRANTY AND RETURNS

WARRANTY POLICY FOR LAVINA®13-S

If your warranty card is missing, call your local distributor and request a warranty card or visit us at www.superabrasive.com to download one.

The customer is responsible for filling out the card and mailing it to the manufacturer's address indicated on the card. To ensure registration and activation of the warranty coverage, the warranty card must be mailed to the manufacturer within 30 days from date of purchase. Failure to mail the warranty card within 30 days from date of purchase may void the warranty. Make sure you provide the manufacturer with all the information requested, and most importantly with the distributor's name, machine serial number and purchase date.

Superabrasive Inc. guarantees that the original purchaser of the Lavina®13-S machine will be covered against defects in material and workmanship for a period of 2 years from the date of delivery or 500 hours of use whichever comes first.

The following conditions pertain to this warranty:

Applies only to the original owner and it is not transferable.

Machine must not be dismantled and tampered with in any way.

Covered components proven defective will be repaired or replaced at no charge. Covered components include motors, bearings and switches.

This warranty does not apply to any repair arising from misuse, neglect or abuse, or to repair of proprietary parts.

This warranty does not apply to products with aftermarket alterations, changes, or modifications.

This warranty is in lieu of and excludes every condition of warranty not herein expressly set out and all liability for any form of consequential loss or damage is hereby expressly excluded.

This warranty is limited to repair or replacement of covered components and reasonable labor expenses.

All warranty returns must be shipped freight prepaid.

The above warranty conditions may be changed only by Superabrasive. Superabrasive reserves the right to inspect and make a final decision on any machine returned under this warranty. This warranty applies to new, used and demo machines.

Superabrasive does not authorize any person or representative to make any other warranty or to assume for us any liability in connection with the sale and operation of our products.

RETURN POLICY FOR LAVINA®13-S

Lavina®13-S machines may be returned, subject to the following terms:

In no case, a machine is to be returned to Superabrasive Inc. for credit or repair without prior authorization. Please contact Superabrasive Inc. or your local distributor for an authorization and issuance of a return authorization number. This number along with the serial number of the machine must be included on all packages and correspondence. Machines returned without prior authorization will remain property of the sender and Superabrasive Inc. will not be responsible for these.

No machines will be credited after 90 days from the date of invoice.

All returns must be shipped freight prepaid. All returns may be exchanged for other equipment or parts of equal dollar value. If machines are not exchanged, they are subject to a fifteen percent (15%) restocking fee.

10. DISPOSAL

If your machine after time is not usable or needs to be replaced, send the machine back to Superabrasive or a local distributor, where a professional disposal complying with the environment laws and directives is guaranteed.

11. MANUFACTURER'S CONTACTS

If you need to contact Superabrasive Inc. with technical support questions, below is the contact information.

Address; 9411 Jackson Trail Road, Hoshton GA 30548, USA

Email: info@superabrasive.us

Tel.: 706 658 1122

Fax: 706 658 0357

Website: www.superabrasive.com

12. SPARE PARTS

ASSEMBLY AND PARTS SPECIFICATIONS

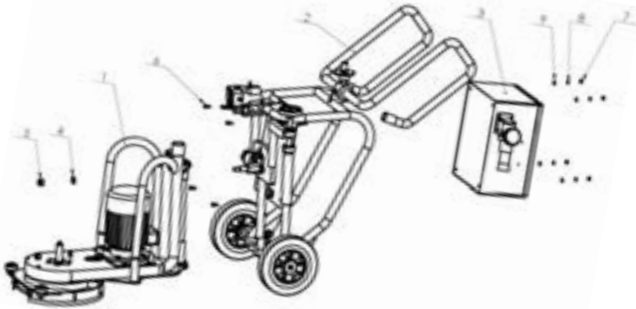

2. LAVINA®13-S MAIN HEAD 1

Model	No.	Item No.	Description	Pcs.
L13-S	1	M10x40DIN933	Bolt	4
L13-S	2	M10DIN125A	Washer	8
L13-S	3	M8DIN125A	Washer	6
L13-S	4	M8x25DIN933	Bolt	4
L13-S	5	M8DIN127B	Spring Washer	4
L13-S	6	L13S-10.70.00	Weights Holder	1
L13-S	7	M5x12DIN6921	Bolt	2
L13-S	8	M4x12DIN85A	ВИНТ M4x12	2
L13-S	9	DWL-K5	Double Water Level	1
L13-S	10	M8x12DIN7991-10.9	Screw	6
L13-S	11	M10DIN127B	Spring Washer	4
L13-S	12	L13S-10.20.00-SET	Frame SET	1
L13-S	13	XPZ 887	Belt	2
L13-S	14	L13S-10.10.00	Driven Bearing	1
L13-S	15	M5x10DIN85A	Screw	6
L13-S	16	M6x12DIN7991	Screw	6
L13-S	17	L13S-10.00.40	Disc Cover	1
L13-S	18	M6x20DIN7991	Screw	8
L13-S	19	L25LS-14.00.02	Flange	1
L13-S	20	M5DIN6798A	Washer	6
L13-S	21	L13S-10.00.20	Cover	1
L13-S	22	M6x20DIN912	Screw	4
L13-S	23	M10DIN93	Safety Washer	1
L13-S	24	M10x70DIN933	Bolt	1
L13-S	25	M6DIN125A	Washer M6	4
L13-S	26	M6DIN985	Self Locking Nut	4
L13-S	27	L13S-10.50.00	Tubular Axle	1
L13-S	28	L7P-00.00.00.02	Handle M12	1
L13-S	29	M6x14DIN912	Screw	3
L13-S	30	M10DIN 934	Nut	4
L13-S	31	L13S-10.30.00	Plate Strain	1
L13-S	32	L25SPS-00.00.00.15	Front Washer	1
L13-S	33	L13S-10.00.08	Belt Sheave	1
L13-S	34	S072	Electro Motor	1
L13-S	34.1	L7NP-00.00.00.11	Fan Cover	1
L13-S	34.2	L7NP-00.00.00.12	Fan	1

1. LAVINA®13-S GENERAL PARTS

Model	No.	Item No.	Description	Pcs.
L13-S	1	L13S-10.00.00	Main Head	1
L13-S	2	L13S-20.00.00	Carriage	1
L20-S	3	L13S-30.00.00	Electric Cabinet	1
L13-S	4	M16DIN125A	Washer	2
L13-S	5	M16DIN982	Self Locking Nut	2
L13-S	6	M8x20DIN933	Bolt	4
L13-S	7	M8DIN934	Nut	4
L13-S	8	M8DIN127B	Spring Washer	4
L13-S	9	M8DIN125A	Washer	4

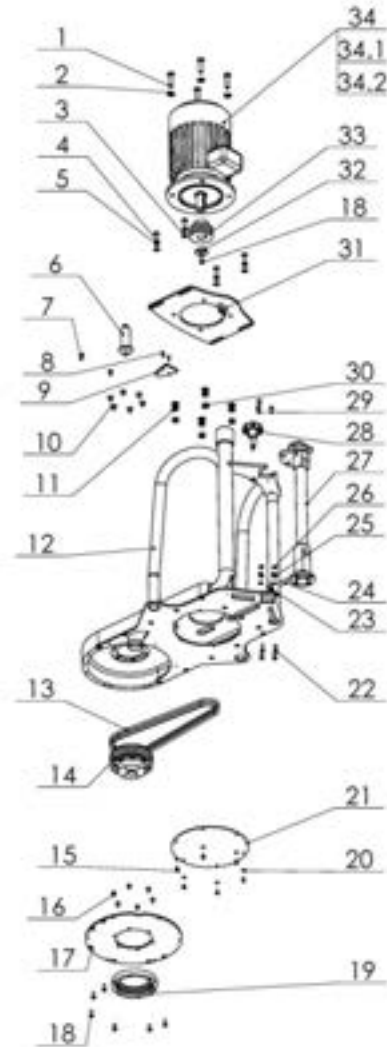

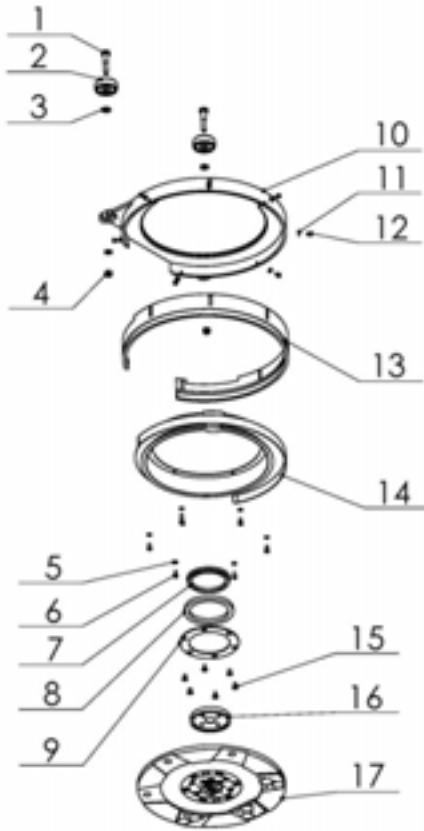

3. LAVINA®13-S MAIN HEAD 2				
Model	No.	Item No.	Description	Pcs.
L13-S	1	L13-S-10.00.22	Axis Roll	2
L13-S	2	PO 050 19 22 OG	Roll PO	2
L13-S	3	M8DIN134	Washer	2
L13-S	4	M8DIN 982	Self Locking Nut	2
L13-S	5	M5DIN6798A	Washer	6
L13-S	6	M5x12DIN85A	Screw	6
L13-S	7	TWVA00800	V-Ring Type A	1
L13-S	8	110X90X8.5	Felt Ring	1
L13-S	9	L25LS-14.00.03	Outer Cover	1
L13-S	10	L13-S-10.00.11	Protecting Disc	1
L13-S	11	M5DIN125A	Washer	7
L13-S	12	M5x8DIN933	Bolt	7
L13-S	13	L13-S-10.00.38	Strip Brush	1
L13-S	14	L13-S-10.40.00	Succer Cover	1
L13-S	15	M6x12DIN7991	Screw	6
L13-S	16	A37.00.01	Adaptor	1
L13-S	17	A35.00.00	Tool Holder A35	1

4. LAVINA®13-S TOOL HOLDER PARTS				
Model	No.	Item No.	Description	Pcs.
L13-S	1	A35.10.00	Quick Change Assembly	1
L13-S	1.1	A31.12.00	Keylock Set	1
L13-S	2	M6X16DIN7991	Screw	4
L13-S	3	A25.00.10-K	Buffer with two screw	6
L13-S	3.1	M8X12DIN7991	Screw	12
L13-S	3.2	A25.00.10	Buffer	6
L13-S	4	A25.00.05-02	Spider	1
L13-S	5	M8X25DIN7991-10.9	Screw	4
L13-S	6	A31.20.00	Flange	1

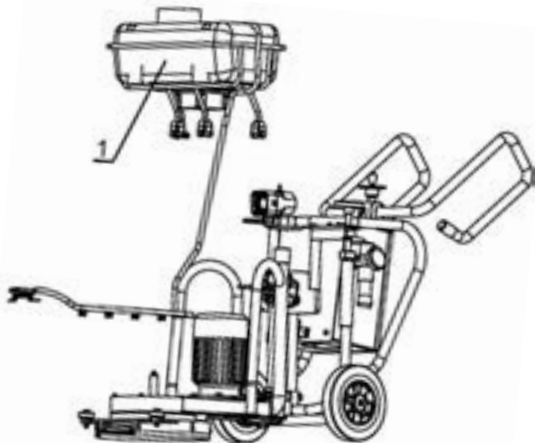
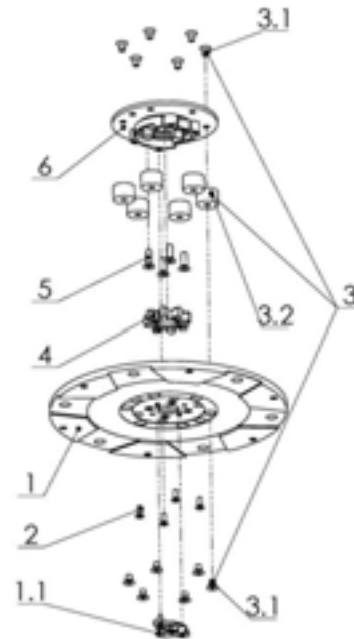

5. LAVINA®13-S OPTION FOR WATER				
Model	No.	Item No.	Description	Pcs.
L13-S	1	L13S-40.00.00	Set Water	1

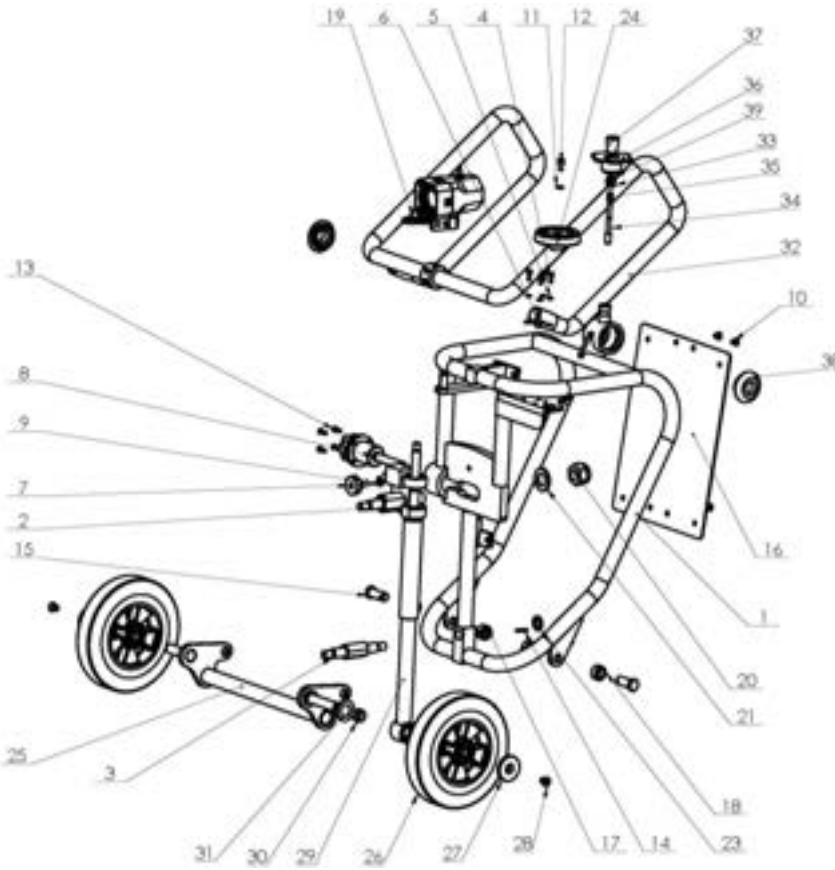

6. LAVINA®13-S CARRIAGE PARTS

Model	No.	Item No.	Description	Pcs.	Model	No.	Item No.	Description	Pcs.
L13-S	1	L13S-20.10.00	Frame	1	L13-S	21	M27DIN125B	Washer	1
L13-S	2	L13S-20.20.00	Axle	1	L13-S	22	M16DIN982	Nut	1
L13-S	3	L13S-20.00.05	Bottom Axle	1	L13-S	23	M16DIN125A	Washer	1
L13-S	4	M6X16DIN912	Screw	4	L13-S	24	L13S-20.00.32	Handle	1
L13-S	5	M6DIN127B	Spring Washer	4	L13-S	25	L13S-21.10.00	Carnage Frame	1
L13-S	6	M6 DIN125B	Washer	4	L13-S	26	L25G -20.00.04	Wheel	2
L13-S	7	F17840	Knob Bolt	1	L13-S	27	L32D.20.00.03	Cap	2
L13-S	8	L13S-20.40.00	Screw Flat	1	L13-S	28	M10X16DIN7991	Screw	2
L13-S	9	M10DIN125A	Washer	1	L13-S	29	L13S-21.20.00	Connecting Rod	1
L13-S	10	M8X12DIN7991	Screw	4	L13-S	30	L13S-21.00.06	Bush	1
L13-S	11	M8DIN433	Washer	1	L13-S	31	L13S-21.00.07	Washer	1
L13-S	12	M8X16DIN912	Screw	1	L13-S	32	L25G-23.00.00	Handle Assembly	1
L13-S	13	M6X20DIN7991	Screw	4	L13-S	33	L13S-20.30.03	Nut	1
L13-S	14	M12 DIN125A	Washer	2	L13-S	34	L13S-20.30.04	Axle	1
L13-S	15	L13S-20.00.21	Axle	2	L13-S	35	L13S-20.30.05	Spring	1
L13-S	16	L13S-20.00.18	Plate	1	L13-S	36	L13S-20.32.00	Wheel	1
L13-S	17	M12 DIN982	Self Locking Nut	2	L13-S	37	BO751107	Conical Handle	1
L13-S	18	L13S-20.00.23	Washer	2	L13-S	38	L25SPS-02.00.00.18-01	Carnage Nut	2
L13-S	19	L20NS-30.30.00	Lamp Unit Incl. Cable	1	L13-S	39	M8DIN439B	Nut	1
L13-S	20	M27DIN985	Nut	1					

7. CONTROL BOX PARTS 200-240 VOLT

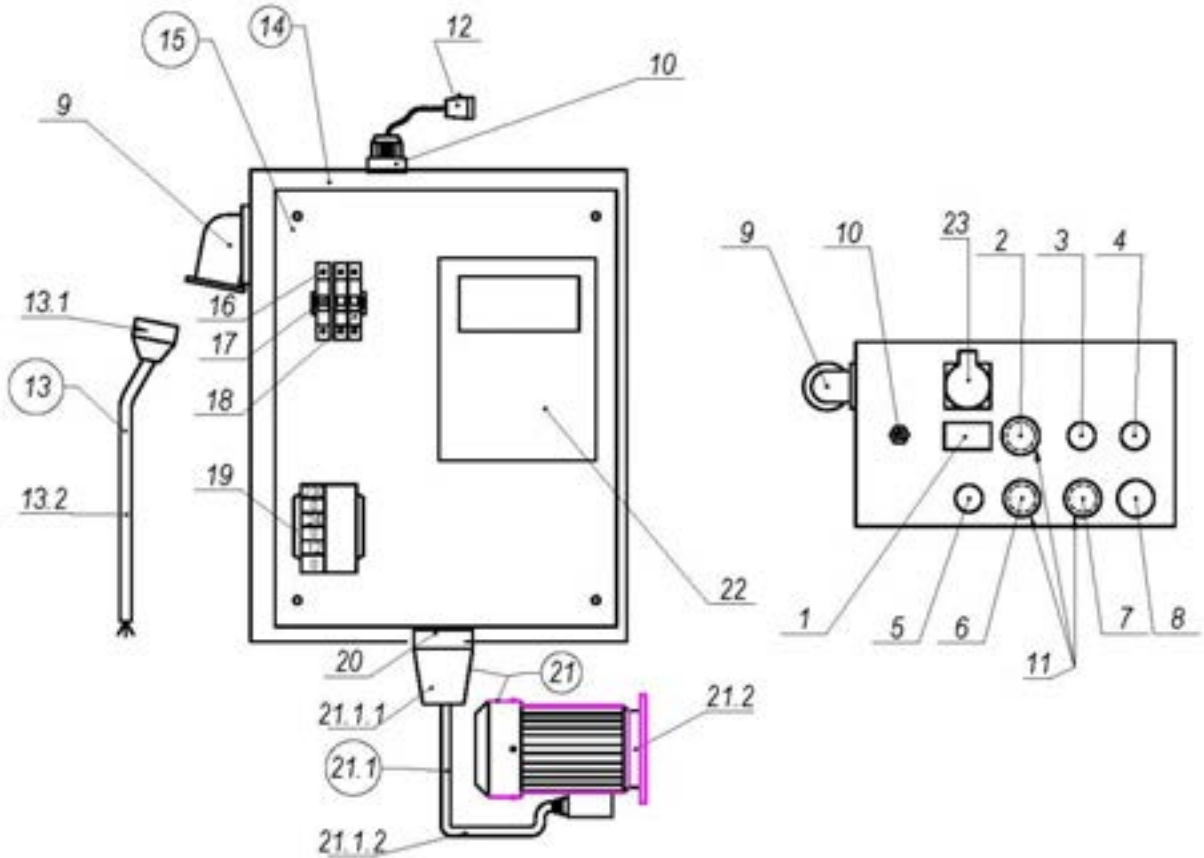

7. LAVINA® 13-S CONTROL BOX PARTS 200-240 VOLT								
Model	No.	Item No.	Description	Pcs.	No.	Item No.	Description	Pcs.
L13-S	1	L20NS-30.10.15	Revolution counter	1	13.2	L20S-30.02.02	Cable	1
L13-S	2	L13S-30.10.12	Button	1	14	L13S-30.10.00	Metal Box	1
L13-S	3	L20NS-30.10.12	Green LED Power	1	15	L13S-30.11.00	Metal Box Plate	1
L13-S	4	L20NS-30.10.11	Switch Button F/R	1	16	L20NS-30.11.01	Circuit Breaker	2
L13-S	5	L20NS-30.10.04	Potentiometer	1	17	L20NS-30.11.02	Rail	1
L13-S	6	L20NS-30.10.07	Off Button	1	18	L20S-30.11.03	Circuit Breaker	1
L13-S	7	L20NS-30.10.08	On Button	1	19	L20NS-30.11.07	Transformer	1
L13-S	8	L20NS-30.10.10	Emergency Stop Button	1	20	L20S-30.10.03	Socket	1
L13-S	9	L20S-30.10.02	Plug on Control Board	1	21	L13S-30.20.00	Electro Motor Assembly	1
L13-S	10	L20NS-30.10.01	Cable Gland	1	21.1	L20S-30.20.10	Plug with Cable	1
L13-S	11	L20NS-30.10.06	Cap	3	21.1.1	L20S-30.20.11	Plug	1
L13-S	12	L20NS-30.30.00	Lamp Unit Incl.Cable	1	21.1.2	L20S-30.20.12	Cable for Electro Motor	1
L13-S	13	L20S-30.02.00	Cable with Connector	1	21.2	S072	Electro Motor	1
L13-S	13.1	L20S-30.02.01	Connector	1	22	L13S-30.11.22	Inverter Yaskawa (V1000)	1
					23	L13S-30.10.23	Panel mounted socket	1