



## BusWorks® 900EN Series – EtherNet/IP™ 10/100Mbps Industrial Ethernet I/O Modules

**Model 961EN-6006 Six Differential Current Inputs**  
**Model 962EN-6006 Six Differential Voltage Inputs**

### USER'S MANUAL



**EtherNet/IP  
CONFORMANCE TESTED™**

**ACROMAG INCORPORATED**  
30765 South Wixom Road  
P.O. BOX 437  
Wixom, MI 48393-7037 U.S.A.

**Tel: (248) 624-1541**  
**Fax: (248) 624-9234**

Copyright 2004, Acromag, Inc., Printed in the USA.  
Data and specifications are subject to change without notice.

**8500-752-B06B001**

## TABLE OF CONTENTS

Symbols on equipment:



Means "Refer to User's Manual (this manual) for additional information".

*The information of this manual may change without notice. Acromag makes no warranty of any kind with regard to this material, including, but not limited to, the implied warranties of merchantability and fitness for a particular purpose. Further, Acromag assumes no responsibility for any errors that may appear in this manual and makes no commitment to update, or keep current, the information contained in this manual. No part of this manual may be copied or reproduced in any form without the prior written consent of Acromag, Inc.*

**EtherNet/IP  
CONFORMANCE TESTED™**

Windows® is a registered trademark of Microsoft Corporation.

The following is a trademark under license by ODVA: EtherNet/IP™.

All trademarks are the property of their respective owners.

## IMPORTANT SAFETY CONSIDERATIONS

You must consider the possible negative effects of power, wiring, component, sensor, or software failure in the design of any type of control or monitoring system. This is very important where property loss or human life is involved. It is important that you perform satisfactory overall system design and it is agreed between you and Acromag, that this is your responsibility.

## GETTING STARTED

<b>MOUNTING AND DIMENSIONS</b> .....	<b>3</b>
<b>CONTROLS &amp; INDICATORS</b> .....	<b>3</b>
<b>ISOLATION BARRIERS</b> .....	<b>3</b>
<b>CONNECTIONS</b> .....	<b>4</b>
<b>DIN-Rail Mounting And Removal</b> .....	<b>4</b>
<b>Network</b> .....	<b>4</b>
<b>Power</b> .....	<b>6</b>
<b>Analog Inputs</b> .....	<b>6</b>
<b>Earth Ground</b> .....	<b>8</b>
<b>WEB BROWSER</b> .....	<b>8</b>
<b>Home Page</b> .....	<b>8</b>
<b>Password Configuration Page</b> .....	<b>9</b>
<b>Network Configuration Page</b> .....	<b>10</b>
<b>Discussion Topic – IP Addressing</b> .....	<b>12</b>
<b>Test Page</b> .....	<b>14</b>
<b>Calibration Page</b> .....	<b>15</b>
<b>Input Calibration</b> .....	<b>17</b>
<b>TROUBLESHOOTING</b> .....	<b>18</b>
<b>Diagnostics Table</b> .....	<b>18</b>
<b>Trouble Browsing Your Module?</b> .....	<b>19</b>
<b>Getting Out Of Trouble</b> .....	<b>19</b>

## TECHNICAL REFERENCE

<b>KEY FEATURES</b> .....	<b>20</b>
<b>HOW IT WORKS</b> .....	<b>21</b>
<b>ETHERNET/IP</b> .....	<b>22</b>
<b>Object Models</b> .....	<b>22</b>
<b>EDS File (Electronic Data Sheet)</b> .....	<b>30</b>
<b>MODBUS TCP/IP</b> .....	<b>32</b>
<b>Modbus Registers</b> .....	<b>32</b>
<b>Register Functions</b> .....	<b>32</b>
<b>Register Mirroring</b> .....	<b>33</b>
<b>Register Data Types</b> .....	<b>34</b>
<b>Register Map</b> .....	<b>35</b>
<b>SPECIFICATIONS</b> .....	<b>43</b>
<b>Model Numbers</b> .....	<b>43</b>
<b>Analog Inputs</b> .....	<b>43</b>
<b>General Specifications</b> .....	<b>44</b>
<b>Enclosure and Physical</b> .....	<b>45</b>
<b>Agency Approvals</b> .....	<b>45</b>
<b>Environmental</b> .....	<b>46</b>
<b>Ethernet Interface</b> .....	<b>47</b>
<b>Controls &amp; Indicators</b> .....	<b>48</b>
<b>ACCESSORY CABLES</b> .....	<b>48</b>

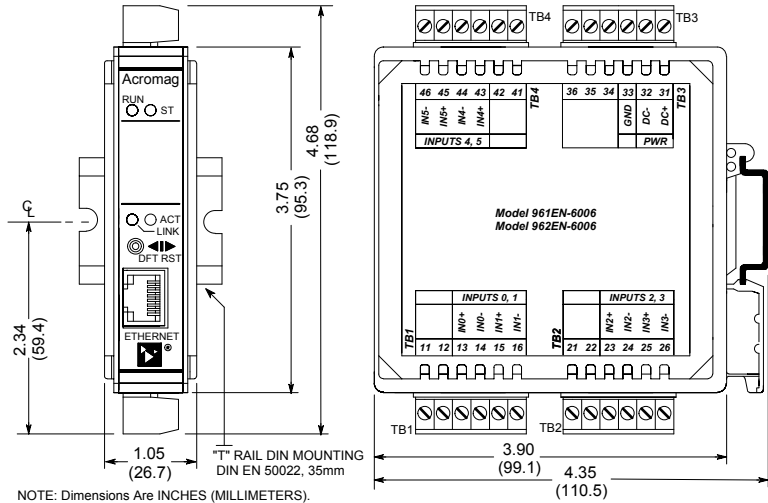

NOTE: Dimensions Are INCHES (MILLIMETERS).

MODEL 961/962EN ENCLOSURE DIMENSIONS

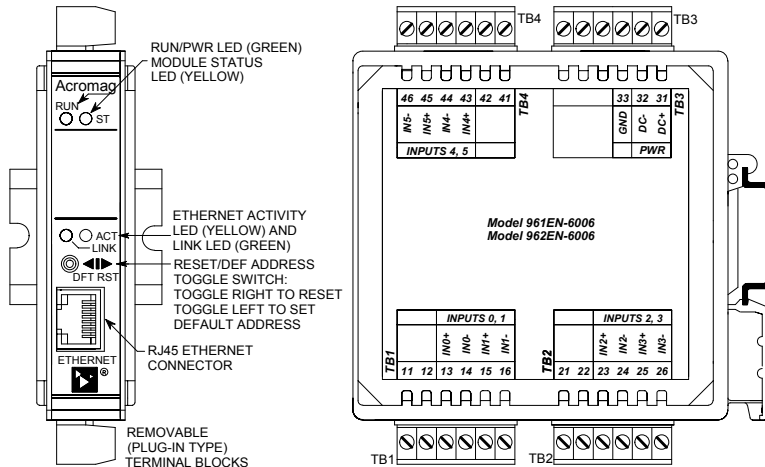

The toggle switch is used to toggle the module into or out of Default Mode (toggle left), or to reset the module (toggle right). In Default Communication Mode, the yellow ST LED blinks slowly and the module assumes a fixed static IP address of "128.1.1.100", a default subnet mask of "255.255.255.0", a default username of "User", and a default password of "password00".

**MOUNTING AND DIMENSIONS**

Unit mounts to "T" type DIN rails (35mm, type EN50022).

Units may be mounted side-by-side on 1-inch centers.

**WARNING:** IEC Safety Standards may require that this device be mounted within an approved metal enclosure or sub-system, particularly for applications with exposure to voltages greater than or equal to 75VDC or 50VAC.

**CONTROLS & INDICATORS**

Green Run LED is ON if power is on and will blink in "wink" ID mode.

Yellow ST LED blinks ON/OFF if module is in default mode and stays ON if an input is out of range.

Green LINK LED ON if auto-negotiation has successfully established a connection.

Yellow ACT LED signals PHY network Activity (busy).

**ISOLATION BARRIERS**

Dashed Lines denote isolation barriers.

The input circuit, network, and power circuit are isolated from each other for safety and noise immunity.

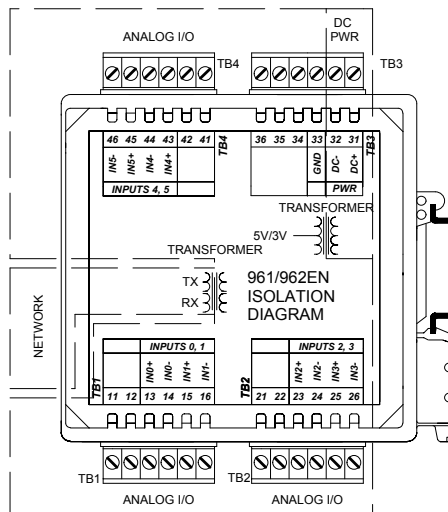

## CONNECTIONS

### DIN-Rail Mounting & Removal

When attaching the module to the T-type DIN rail, angle the top of the unit towards the rail and locate the top groove of the adapter over the upper lip of the rail. Firmly push the unit towards the rail until it snaps into place. To remove, first separate the input terminal block(s) from the bottom side of the module to create a clearance to the DIN mounting area. Next, while holding the module in place from above, insert a screwdriver into the lower arm of the DIN rail connector and use it as a lever to force the connector down until the unit disengages from the rail (do not twist the screwdriver to avoid damaging plastic).

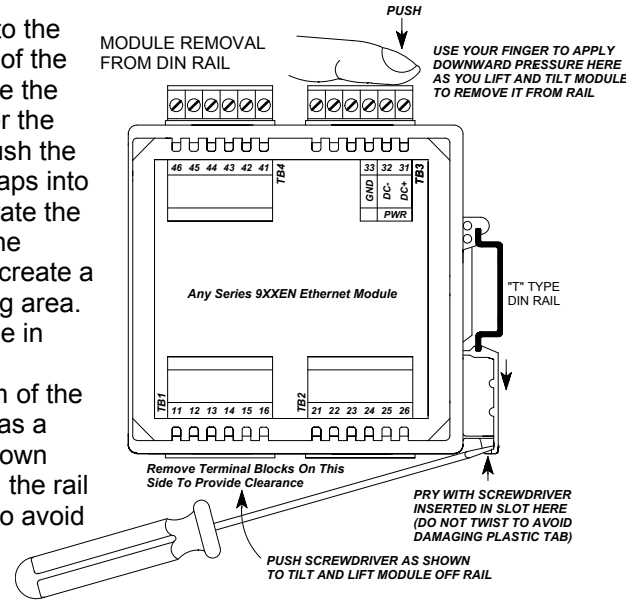

### Network

For 100Base-TX systems, use data grade Unshielded Twisted-Pair (UTP) wiring that has a 100Ω characteristic impedance and meets the EIA/TIA Category Five wire specifications.

It is recommended that you use a crossover CAT-5 cable to connect this device to your PC.

For 10Base-T systems, you may use Category 3, Category 4, or Category 5 UTP cable.

In either case, you are limited to 100 meters between any two devices.

A crossover cable simply connects the differential transmit pair on each end, to the receive pair on the opposite end.

Use a standard (direct) cable when connecting to a hub or switch port, which are generally wired MDI-X.

### RJ45 MDI AND MDI-X CONNECTIONS

PIN	MDI WIRING	MDI-X WIRING
1	Transmit +	Receive +
2	Transmit -	Receive -
3	Receive +	Transmit +
4	Not Used	Not Used
5	Not Used	Not Used
6	Receive -	Transmit -
7	Not Used	Not Used
8	Not Used	Not Used

Note Crossover Connections

### RECOMMENDED CABLE

SPEED	DISTANCE	CABLE
10Base-T	100M	CAT 3, CAT 4, or CAT 5 UTP
100Base-T	100M	CAT 5/5e UTP/STP

### ETHERNET PORT

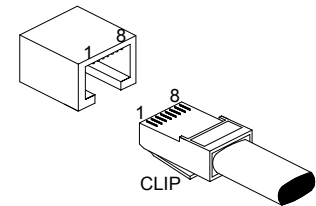

RJ-45 CONNECTOR

The Ethernet port of this module is wired MDI and does not include automatic crossover. The Ethernet port of your PC is also wired MDI and may not include automatic crossover. As such, you must use a crossover cable like that shown below when connecting this device directly to a PC.

### CROSSOVER CABLE FOR MDI TO MDI OR MDI-X TO MDI-X

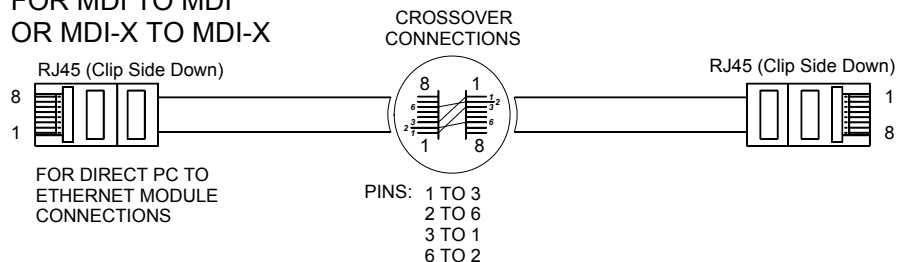

Refer to the section “Cable Accessories” at the back of this manual for more information on accessory cables including patch and crossover cables available from Acromag and other vendors.

## CONNECTIONS

### Network

**TIP:** You can significantly enhance the EMI/RFI performance of your network connections by using Category 5E STP cable (Shielded Twisted Pair) with shielded RJ45 plug connectors. This will also help to protect your installation from damage due to ESD (Electro-Static Discharge). The use of shielded cable is strongly recommended for installations in harsh industrial environments and/or in the presence of strong electrical fields.

### HOST PC CONNECTED DIRECTLY TO A MODULE

Note: This MDI-to-MDI connection requires the use of a crossover cable.

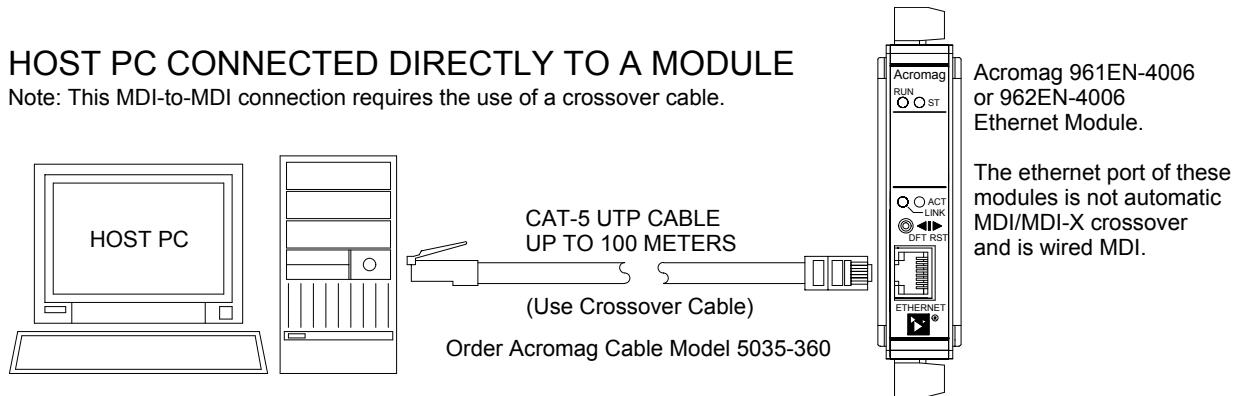

Acromag 961EN-4006 or 962EN-4006 Ethernet Module.

The ethernet port of these modules is not automatic MDI/MDI-X crossover and is wired MDI.

You can use an Ethernet switch or switching hub to build a network of Ethernet modules, similar to that shown below. This drawing shows how to network-connect Acromag Series 9xxEN modules to a 5-port Ethernet switch (Acromag Model 900EN-S005). Note that the 900EN-S005 switch includes automatic MDI/MDI-X crossover and a straight-through or crossover cable(s) may be used to connect to the modules and the PC.

### USE OF AN ETHERNET SWITCH TO NETWORK A HOST PC TO MORE THAN ONE MODULE

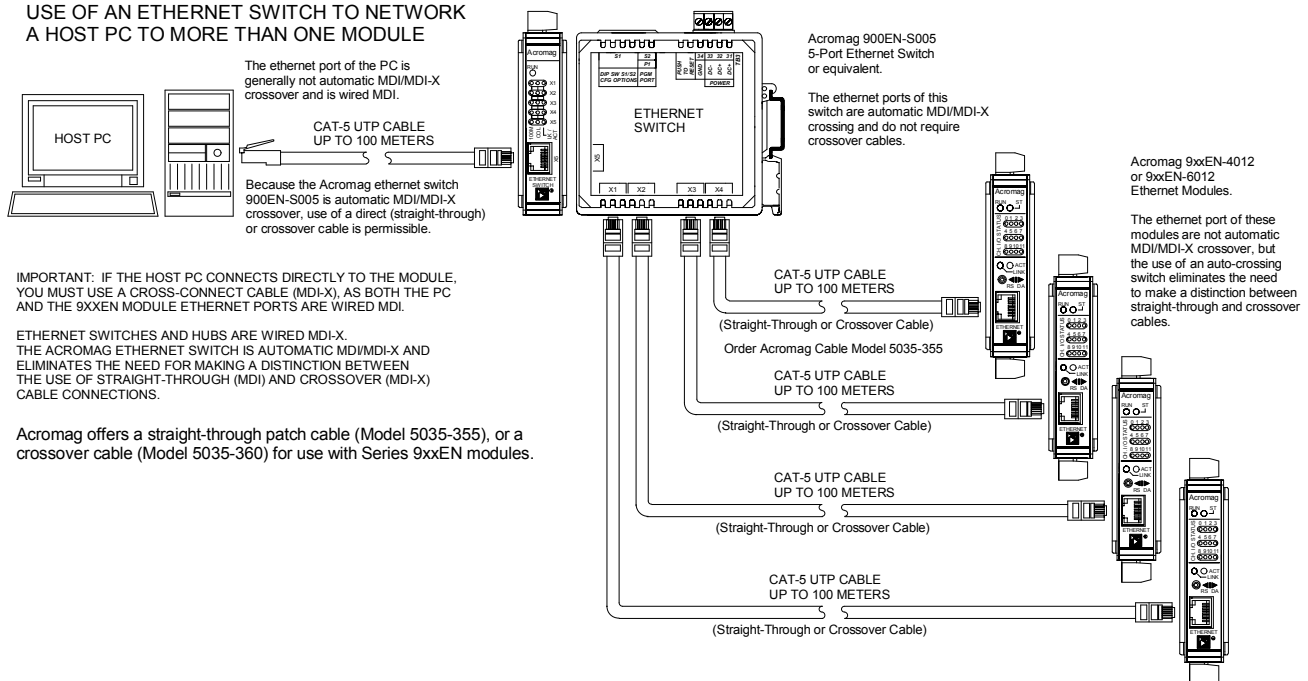

## CONNECTIONS

### Power

Voltage	Current
15VDC	113mA
18VDC	95mA
24VDC	74mA
36VDC	55mA

- ✓ Connect 15-36V DC to the power terminals labeled DC+ & DC-. Observe proper polarity. For supply connections, use No. 14 AWG wires rated for at least 75°C. **CAUTION:** Do not exceed 36VDC peak.

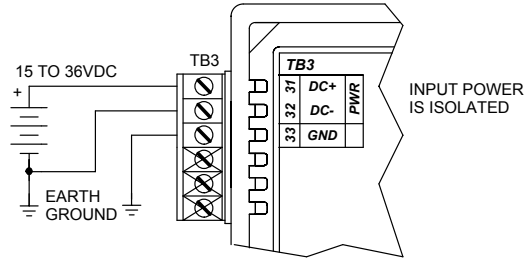

**CAUTION:** Risk of Electric Shock – More than one disconnect switch may be required to de-energize this equipment before servicing.

**IMPORTANT – External Fuse:** If unit is powered from a supply capable of delivering more than 1A to the unit, it is recommended that this current be limited via a high surge tolerant fuse rated for a maximum current of 1A or less (for example, see Bel Fuse MJS1).

### Analog Inputs

Input is DC current (961EN), or DC voltage (962EN), according to model number.

Inputs are not isolated channel-to-channel, except for small common mode voltages up to ±12V peak (962EN), or ±5V peak (961EN).

- ✓ Connect analog input signals to the input terminals as shown below according to your model.

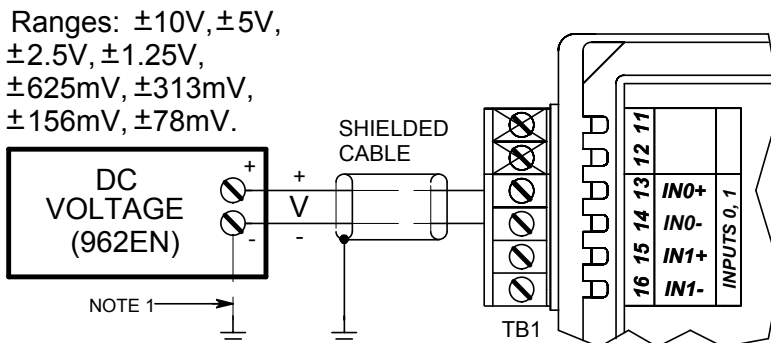
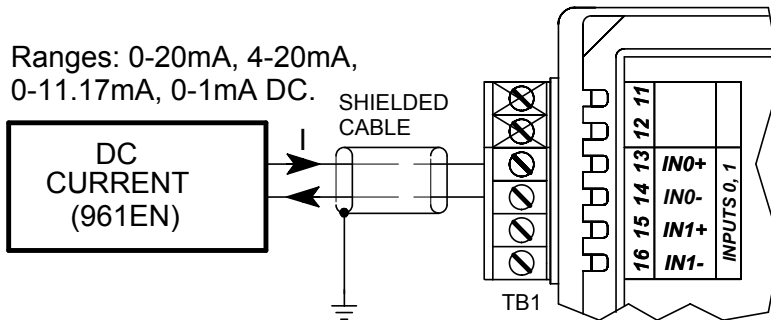

NOTE 1: THIS GROUND CONNECTION IS RECOMMENDED FOR BEST RESULTS. IF SENSORS ARE INHERENTLY CONNECTED TO GROUND, USE CAUTION AND AVOID MAKING ADDITIONAL GROUND CONNECTIONS WHICH COULD GENERATE GROUND LOOPS AND MEASUREMENT ERROR.

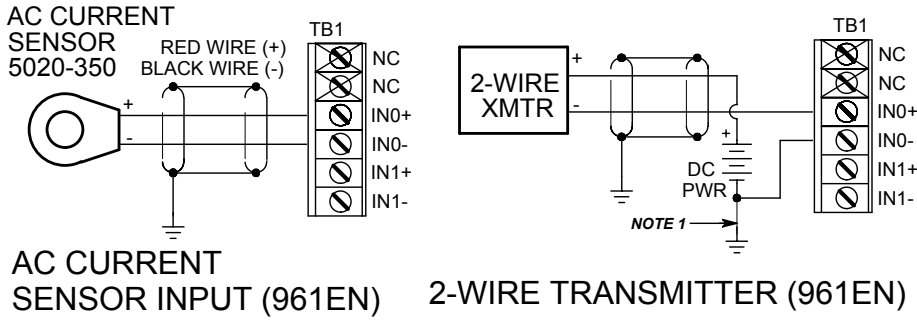

## CONNECTIONS

### Analog Inputs

Connections to an optional AC current sensor or two-wire transmitter (961EN Only)

Although the 961/962EN are not isolated channel-to-channel, they do provide common mode isolation for low level voltages in the range of  $\pm 5V$  (961EN), and  $\pm 12V$  (962EN) peak. This makes these models useful for differential current and voltage monitoring applications similar to the examples shown here.

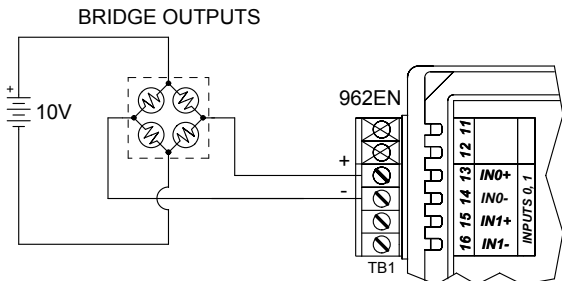
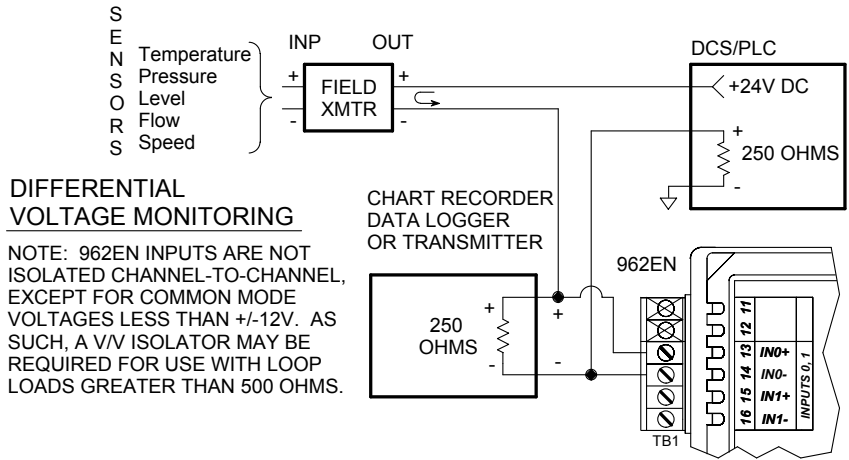
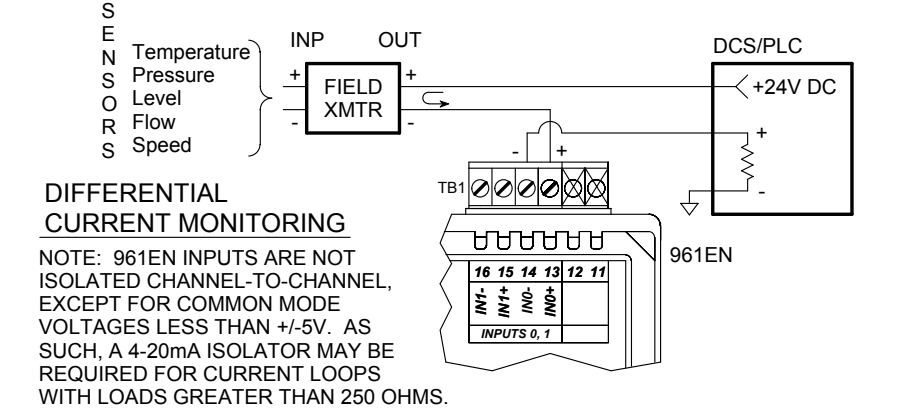



## Earth Ground

**Warning:** To comply with safety and performance standards, use shielded cable and connect earth ground as noted. Failure to use good wiring and grounding practices may be unsafe and hurt performance.

- ✓ Connect Earth Ground as shown in the connection drawings above. Additionally, connect the GND terminal (TB3-33) to earth ground.

The ground connections noted are recommended for best results. If sensors are already grounded, use caution and avoid making additional ground connections which could create ground loops.

**The plastic module housing does not require earth ground.**

## WEB BROWSER

### Home Page

This module supports Modbus over TCP/IP. You may use your own software to issue Modbus command to this module (see Modbus Registers), or you may use a standard web browser, as these modules have built-in web pages that allow you to setup, control, and calibrate the module. Simply execute your web browser, type the IP address assigned to your module in the "Address" window (<http://128.1.1.100/> for our example), click [Go], and you will be presented with a Home Page window similar to that shown below:

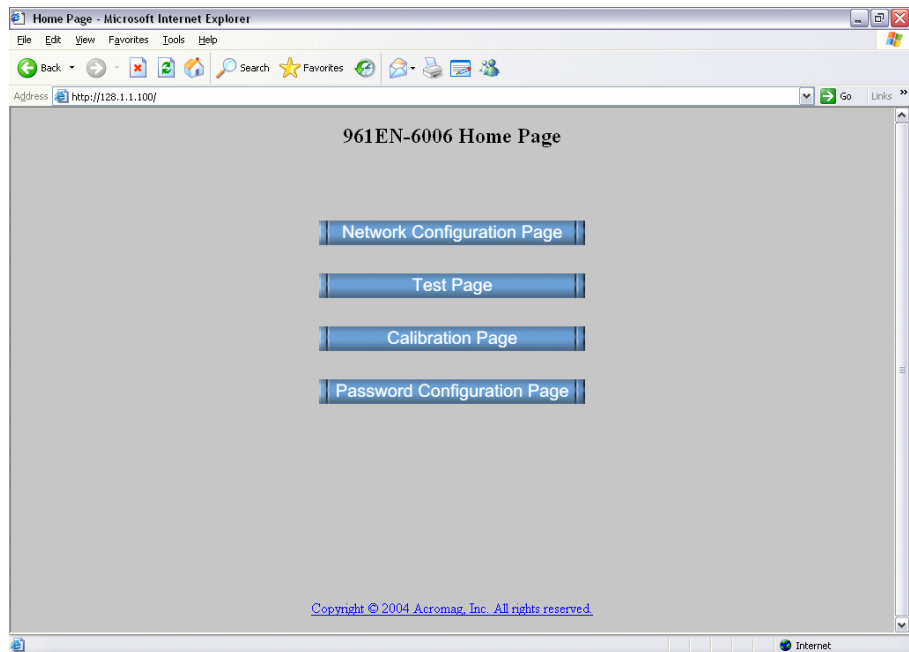

The Home Page provides buttons to access the other web pages of this module that are used to configure the network parameters, change the user name and password, calibrate the module, and operate/test the module.

For each new browser session that accesses the Home Page of this module, you will be presented with a window prompting you to enter the current User Name and Password as shown below. This information is required before the program will allow you to make any other selections. **The default user name and password is "User" and "password00" respectively.** After entering these defaults, you may wish to invoke the Password Configuration Page to change these parameters to something more meaningful to you.





**IMPORTANT:** If you forget your installed user name & password, you can always toggle the module into default mode via the default mode toggle switch at the front of the module. Then the password and username will revert to the original defaults noted on the previous page, allowing you to re-invoke the Password Configuration Page and change the username and password settings as required.

## WEB BROWSER

### Home Page

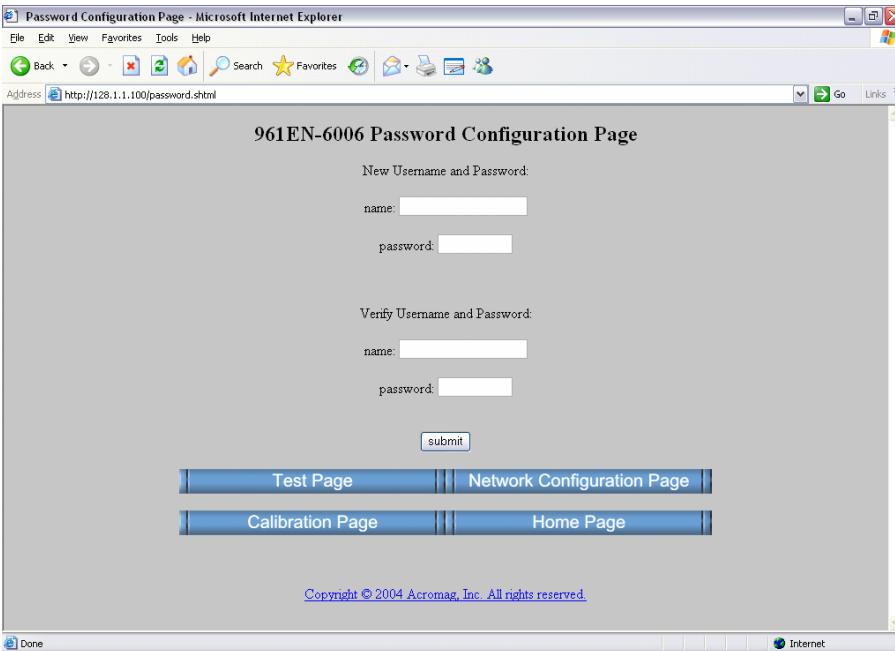

### Password Configuration Page

*Use up to 20 alphanumeric characters (case sensitive) to specify your username, and 10 alphanumeric characters (case sensitive) to specify a password. You will have to type in these entries twice to help prevent errors (yes, I know this is annoying).*

*Click the **submit** button to write your changes to the module.*

After completing your username/password changes, click on the appropriate button at the bottom of the page to select another web page. If you made changes, you may be prompted to re-enter your new username and password before being permitted to move to other pages.

## WEB BROWSER

### Network Configuration

*Note that Acromag Series 9xxEN Ethernet I/O modules may take from 3-30 seconds to boot upon power-up, depending on your network configuration and whether a DHCP server is present.*

You can click the “Network Configuration Page” button to set the network configuration parameters for the module. You may have to consult your network administrator for help to complete the contents of this page.

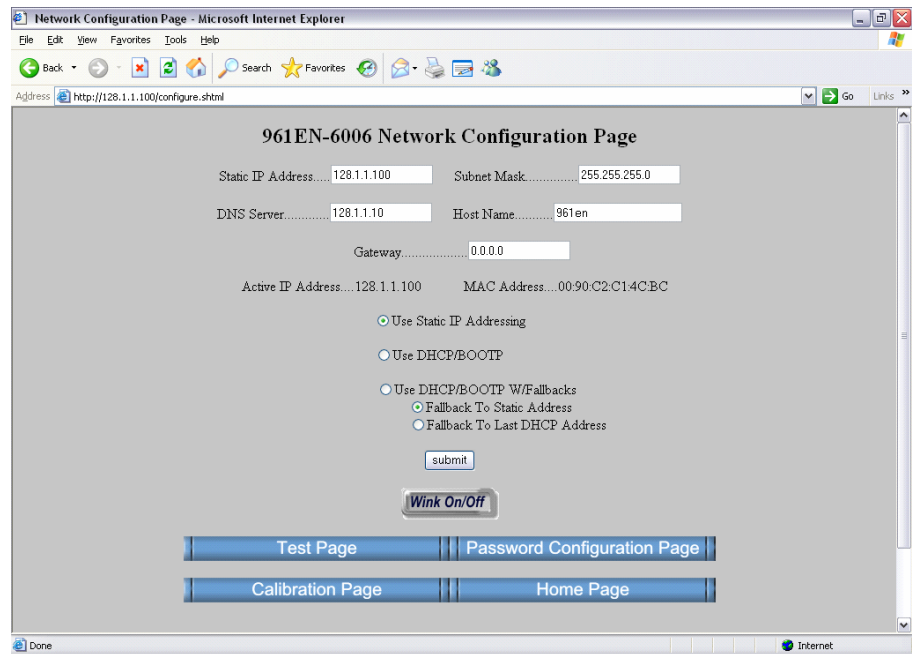

An **IP Address** is a unique identification number for any host (this module) on any TCP/IP network (including the internet). The IP address is made up of four octets (8 bits), each octet having a value between 0-255 (00H-FFH). It is expressed here in decimal form, with a period placed between octets.

A **Static IP Address** is as the name implies—*static*, and represents a unique fixed IP Address that is generally assigned by your service provider or system administrator. The default static IP address assigned to this module from the factory is 128.1.1.100 (refer to product side label).

**NOTE:** In order to network your PC with an Acromag module, you may have to consult with your network administrator and either temporarily change your TCP/IP configuration (see TCP/IP Properties of Network Configuration in Windows), or create a separate private network using a second network adapter installed in your PC (recommended). The necessary steps will vary with your operating system. Refer to Acromag Application Note 8500-734 to help accomplish this (located on the CDROM shipped with your module or via download from our web site at [www.acromag.com](http://www.acromag.com)).

The **DNS Server** refers to the IP address of the Domain Name Server used on this network. A DNS server relates symbolic names to actual IP addresses, while the DHCP server is responsible for dynamically passing out IP addresses.

A **Subnet Mask** is used to subdivide the host portion of the IP address into two or more subnets. The subnet mask will flag the bits of the IP address that belong to the network address, and the remaining bits correspond to the host portion of the address. The unique subnet to which an IP address refers to is recovered by performing a bitwise AND operation between the IP address and the mask itself, with the result being the sub-network address.

**Gateway** refers to the IP Address of the gateway, if your local area network happens to be isolated by a gateway. Typically, it is assigned the first host address in the subnet. If a gateway is not present, then this field should contain an unused address within the host subnet address range.

The **Host Name** is the name to be assigned to this host if its address happens to be assigned dynamically using DHCP.

The **Active IP Address** refers to the current IP Address being used by this host, as opposed to any new assignments being made via this page.

The **MAC Address** refers to the Media Access Control Address that uniquely identifies the hardware of this device. This is a unique fixed address assigned to this module at the factory. On IEEE 802 networks, the Data Link Control (DLC) layer of the OSI Reference Model is divided into two sublayers: the Logical Link Control (LLC) layer, and the Media Access Control (MAC) layer. The MAC layer interfaces directly with the network media (each different type of network media requires a different MAC layer).

By default, the module is setup to use **Static IP Addressing and a Static IP Address of 128.1.1.100**. You can optionally choose to have the IP address assigned dynamically via DHCP/BOOTP or DHCP/BOOTP w/Fallback. This will also require that you specify a valid Host Name. Note that DHCP/BOOTP w/Fallback will revert to the static IP address if your DHCP or BOOTP server cannot be found at the address specified.

In general, BOOTP (Bootstrap Protocol) refers to an internet protocol that enables a diskless workstation to discover its own IP address, the address of a BOOTP server on the network, and a file to be loaded into memory to boot the machine. This enables the workstation or device server to boot without requiring a hard or floppy disk drive. BOOTP works similar to DHCP, but is usually found in older systems. This protocol is defined by RFC 951.

DHCP refers to Dynamic Host Configuration Protocol and is a method used to dynamically assign temporary numeric IP addresses as required. With dynamic addressing, a device can have a different IP address every time it connects to the network. In some systems, it can even change while it is still connected. In general, a DHCP server maintains a pool of shared IP addresses which are dynamically assigned and recycled. When a DHCP device wants to use a TCP/IP application, it must request an IP address from the DHCP server. The DHCP server will check the shared supply, and if all addresses are in use, the server will send a busy signal to the client which tells it to try again later. Thus, although static IP addresses will ensure a connection every time, dynamic addresses will not.

DHCP also supports a combination of static and dynamic IP addresses. You can select "DHCP/BOOTP w/Fallback" and automatically revert to either a static IP address, or the last DHCP assigned IP address, if the DHCP or BOOTP server cannot be found.

## WEB BROWSER

### Network Configuration

*Note that Acromag Series 9xxEN Ethernet I/O modules may take from 3-30 seconds to boot upon power-up, depending on your network configuration and whether a DHCP server is present.*

## WEB BROWSER

### Network Configuration

*The Default Communication Mode uses a static IP address of "128.1.1.100", a default subnet mask of "255.255.255.0", a default username of "User", and a default password of "password00".*

DNS refers to the Domain Name System or Domain Name Server and refers to the system used to associate an alphanumeric character string with a numeric IP address. The DNS is actually a distributed database of domain names and corresponding IP addresses. These servers contain information on some segment of the domain name space and make this information available to clients called *resolvers*. For example, the DNS allows us to use "Acromag.com" as an IP address rather than a complicated number string.

The unit includes a default address toggle switch to cause the module to assume a preset default factory address. This switch is at the front of the module and is used to toggle the module into, or out of Default Mode. If you use the toggle switch at the front of the module to place the module in default mode, then "Default Communications Mode" will be indicated at the bottom of this screen.

Click the **Submit** button to complete any changes made on this page.

Click the **Wink On/Off** button to toggle the module in/out of "wink" ID mode. In this mode, the module's green RUN LED will blink to confirm identification as an aide to locating a specific module on a network.

You may refer to the following section to learn more about IP Addressing terms and concepts, or you can skip ahead to the Test Page.

### Discussion Topic - IP Addressing

A host is any device on any network. On TCP/IP networks, each host has one or more unique IP addresses. This module connected to an Ethernet network may be referred to as a host.

An IP Address is a unique identification number for any host (this module) on any TCP/IP network (including the internet). The IP address is made up of four octets (8 bits), each octet having a value between 0-255 (00H-FFH).

The IP address is comprised of two parts: the network address (first part) and the host address (last part). The number of octets of the four total that belong to the network address depend on the Class definition (see below).

A *Static IP Address* is as the name implies—static. That is, it is a unique IP Address that is assigned by a service provider and never changes.

A *Dynamic IP Address* is an address that is temporarily assigned to a user by a service provider each time a user connects.

A *Subnet* is a contiguous string of IP addresses. The first IP address in a subnet is used to identify the subnet, while the last IP address in a subnet is always used as a broadcast address. Anything sent to the last IP address of a subnet is sent to every host on that subnet.

Subnets are further broken down into three size classes based on the 4 octets that make up the IP address. A Class A subnet is any subnet that shares the first octet of the IP address. The remaining 3 octets of a Class A subnet will define up to 16,777,214 possible IP addresses ( $2^{24} - 2$ ). A Class B subnet shares the first two octets of an IP address (providing  $2^{16} - 2$ , or 65534 possible IP addresses).

Class C subnets share the first 3 octets of an IP address, giving 254 possible IP addresses. Recall that the first and last IP addresses are always used as a network number and broadcast address respectively, and this is why we subtract 2 from the total possible unique addresses that are defined via the remaining octet(s).

For our example, the default IP address of this module is 128.1.1.100. If we assume that this is a Class C network address (based on the default Class C subnet mask of 255.255.255.0), then the first three numbers represent this Class C network at address 128.1.1.0, the last number identifies a unique host/node on this network (node 100) at address 128.1.1.100.

A *Subnet Mask* is used to determine which subnet an IP address belongs to. The use of a subnet mask allows the network administrator to further divide the host part of this address into two or more subnets. The subnet mask flags the network address portion of the IP address, plus the bits of the host part that are used for identifying the sub-network. By convention, the bits of the mask that correspond to the sub-network address are all set to 1's (it would also work if the bits were set exactly as in the network address). It's called a mask because it can be used to identify the unique subnet to which an IP address belongs to by performing a bitwise AND operation between the mask itself, and the IP address, with the result being the subnetwork address, and the remaining bits the host or node address.

For our Example, if we wish to further divide this network into 14 subnets, then the first 4 bits of the host address will be required to identify the subnetwork (0110), then we would use "11111111.11111111.11111111.11110000" as our subnet mask. This would effectively subdivide our Class C network into 14 subnetworks of up to 14 possible nodes each.

With respect to the default settings of this module:

Subnet Mask 255.255.255.0 (11111111.11111111.11111111.00000000)  
IP Address: 128.1.1.100 (10000000.00000001.00000001.01100100)  
Subnet Address: 128.1.1.0 (10000000.00000001.00000001.00000000)

The subnetwork address of 128.1.1.0 has 254 possible unique node addresses (we are using node 100 of 254 possible). Nodes 0 (first node) and 10 are typically reserved for servers and may yield poor results if used. Node 255 (last node in the subnet) is reserved as a broadcast address for the subnet.

## Discussion Topic - IP Addressing

*TIP: The first node (0) and node 10 are typically reserved for servers and may yield poor results if used. The last node is reserved as a broadcast address for the subnet.*

## WEB BROWSER

### Test Page

The Test Page will allow you to read inputs and change input ranges on this model.

After completing your username and password assignment, plus your network configuration parameters, you can use the Test Page to operate your module.

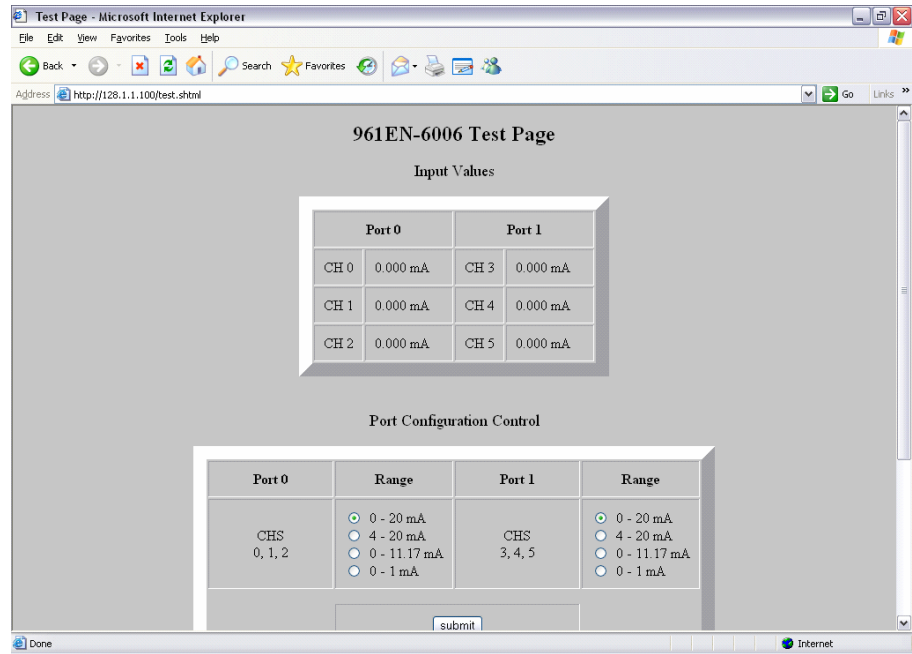

**TIP:** Viewing a module's web page is treated similar to viewing a web page on the internet. The first time you open a page, its image is stored as a temporary internet file in PC memory. However, each subsequent attempt to view that page will need to automatically update that image, especially when making configuration changes. With Internet Explorer, click the "Internet Options" of the "Tools" menu, select the "General" tab, locate the "Temporary Internet Files" information and click on the "Settings" button. Then select "Automatically" under "Check for newer versions of stored pages:". Then click [OK] to return to the "General" screen, and click [OK] again to save your settings.

Use the scroll bar on the right to scroll down the page as shown below:

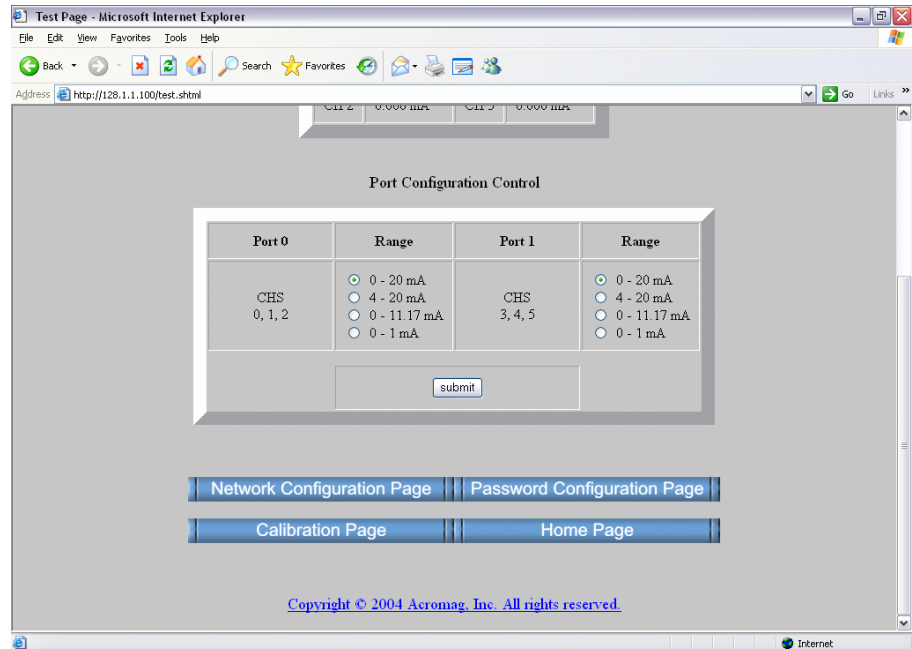

Note that the 6 channels of these modules are divided into 2 groups of 3 channels each. Note that the channels of each group (0, 1, & 2, and 3, 4, & 5) share the same input configuration, but the configuration may vary between the two groups. The input configuration of the fourth channel of four channel models may differ from the configuration of the first 3 channels.



**IMPORTANT:** The input signal indicated only reflects the level of the inputs at the moment this screen is invoked and this does not continuously update. You can click your browser's refresh button to get a new input update.

You can also use the Configuration Control of this page to change the input range for each channel group (0, 1, & 2 or 3, 4, & 5). For the 961EN shown, you may select from 0-20mA, 4-20mA, 0-11.17mA, and 0-1mA DC current ranges. For the 962EN, you may select ±10V, ±5V, ±2.5V, ±1.25V, ±625mV, ±313mV, ±156mV, or ±78mV DC voltage ranges. Note that your range selection will apply to all channels of the group. Click on "submit" to execute your range change.

The Calibration Page will allow you to recalibrate each channel's zero and span signal as required. Simply select the channel to be calibrated, choose zero or span, apply the zero or full-scale signal to the input, then click calibrate. For best results, always calibrate zero before span.

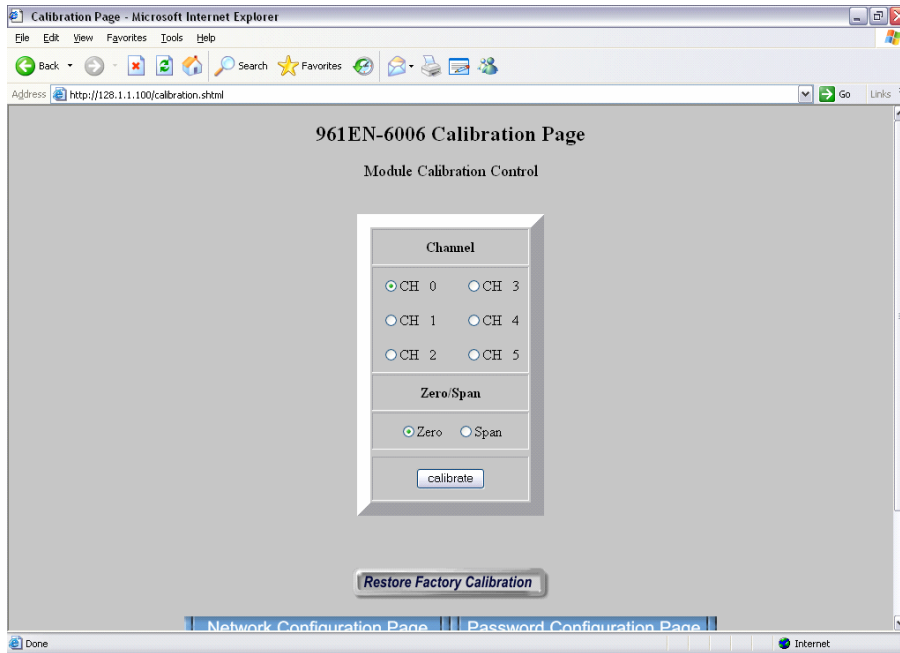

Use the scroll bar on the right to scroll down the page as shown below:

If recalibration of any input is required, all applicable ranges should be done. The table of the following page gives the calibration values for the input ranges of these models. These are the input signals required to calibrate the range endpoints.

*Your success in recalibrating the input will strongly depend upon the accuracy and precision of your signal source.*

Note that on the 961EN-6006, the 4-20mA range is a sub-range of the 0-20mA range and is automatically calibrated at the same time.

## WEB BROWSER

### Test Page

### Calibration Page

**IMPORTANT:** This module has already been calibrated at the factory and recalibration is not normally required, except as necessary to correct for long term component aging, or to satisfy your company's maintenance requirements. Do not attempt to recalibrate this module unless absolutely required, as miscalibration will negatively affect the module's performance.



## WEB BROWSER

### Calibration Page

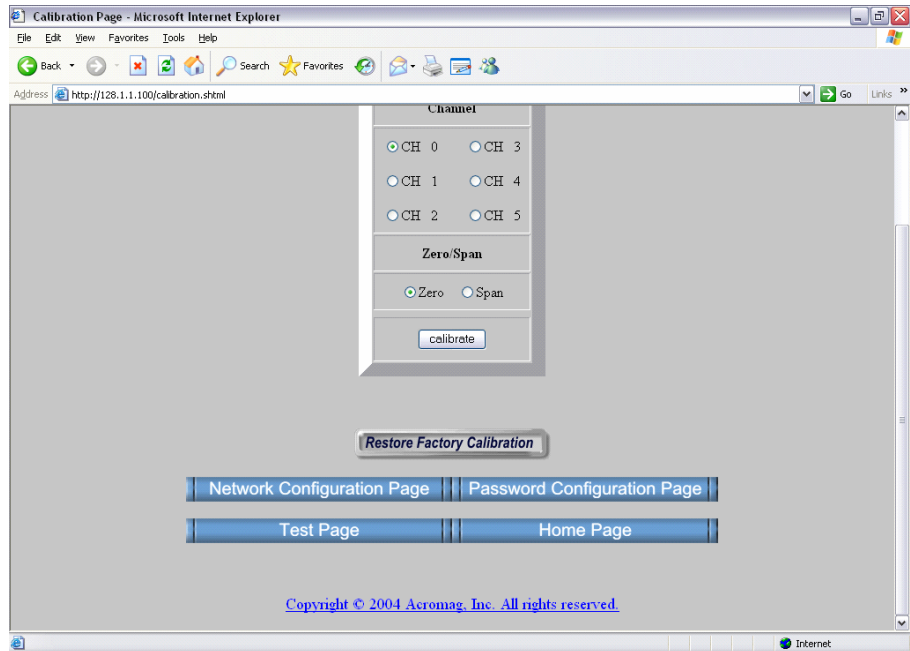

RANGE	ZERO Calibration	FS Calibration
<b>Model 961EN-6006</b>		
0-20mA DC, 4-20mA DC	1.0mA	20.0mA
0-11.17mA DC	1.0mA	11.17mA
0-1mA DC	0.25mA	1.00mA
<b>Model 962EN-6006</b>		
±10V DC	-10000.0mV	10000.0mV
±5V DC	-5000.0mV	5000.0mV
±2.5V DC	-2500.0mV	2500.0mV
±1.25V DC	-1250.0mV	1250.0mV
±625mV DC	-625.0mV	625.0mV
±313mV DC	-312.50mV	312.50mV
±156mV DC	-156.25mV	156.25mV
±78mV DC	-78.13mV	78.13mV

You can choose to use the web browser calibration page to accomplish calibration (Method 1, easiest), or via direct register access as described in Method 2 of the following page:

**Note (961EN):** The 4-20mA range is calibrated when the 0-20mA range is calibrated and is not calibrated separately. All other ranges are calibrated separately.

## WEB BROWSER

### Input Calibration

*You can choose to use the web browser calibration page to accomplish calibration (easiest), or via direct register access as described below.*

#### **Method 1 – Calibration Using The Built-In Browser Interface:**

1. Make sure that the range that needs calibrating is currently selected.
2. Bring up browser interface and select calibration page.
3. Apply either the zero or span input signal to the channel to be calibrated. Calibrate the zero endpoint signal first, before the span endpoint signal.
4. Wait about 10 seconds for the input to settle and be read.
5. Click on the channel number and select either zero or span calibration.
6. Click on the “Calibrate” button. The page will refresh and calibration may continue. Repeat this process for the other endpoint (span).
7. Repeat steps 2-6 for the other input channels to be calibrated.

In the following procedures, information that is specific to the EtherNet/IP interface is contained in braces [ ].

#### **Method 2 - Calibration Via Modbus TCP/IP & [EtherNet/IP] Interface:**

1. Write to the appropriate Port Input Range Register [attribute] to select the input range to be calibrated for your channel of interest.
2. Write 24106 (5E2AH) into the Calibration Access Register [Discrete Output 0] to remove write protection from the calibration registers.
3. Apply the zero calibration signal (Cal Lo, see table) to the input to be calibrated and allow the input to settle about 10 seconds.
4. Write a 16-bit value to the Zero Calibration Register [Discrete Output Word 2] with a set bit in the bit position that corresponds to the channel number to be calibrated (one channel at a time). If you were calibrating the zero of channel 5, you would write 0x0020 to the Zero Calibration Register [Discrete Output Word 2]. The module will replace calibration coefficients immediately, no reset needed.
5. Apply the full-scale calibration signal (Cal Hi, see table) to the input to be calibrated and allow the input to settle about 10 seconds.
6. Write a 16-bit value to the Span Calibration Register [Discrete Output Word 1] with a set bit in the bit position that corresponds to the channel number of the channel to be calibrated (one channel at a time). For example, if you wanted to calibrate the span of channel 0, write 0x0001 to the “Span Cal Register” [Discrete Output Word 1].
7. Write to the Port Input Range Register [attribute] to select the next range to be calibrated for this channel. Repeat steps 3-6 for the next range as required.
8. Repeat steps 3-7 for the other channels as required.
9. When finished calibrating, write 0x0000 to the Calibration Access Register of Holding Register 21 [Discrete Output Word 0] to replace write protection to the calibration registers [values] and prevent miscalibration.

## TROUBLE-SHOOTING

Upon power-up, the green "Run" LED should light. A continuous blinking Run LED indicates "wink" ID mode. If the Run LED remains OFF and correct power has been applied, then either the internal power supply has failed or a fatal processor error (firmware) has occurred.

### Diagnostics Table

SYMPTOM	POSSIBLE CAUSE	POSSIBLE FIX
<i>Green RUN LED does not light.</i>	Internal +3.3V power has failed.	Return module for repair.
<i>Continuous flashing green RUN LED.</i>	Module in "wink" mode.	Read Module Status register to verify "wink" status. Write 5555H to Wink Mode Toggle Register to toggle wink mode off/on.
<i>Cannot communicate.</i>	Power ON at the module?	Check power. Is green RUN LED ON?
	Connecting cable is not a crossover cable.  <i><b>TIP:</b> To check cable type, hold both ends in same position and read the wire colors through the clear portion of the plug from left to right. If colors are arranged in the same order, you have a straight cable.</i>	This module's ethernet port is wired MDI. You must use a crossover cable when connecting this module to your PC or another device also wired MDI. If you are connecting to an Ethernet switch or hub, then a direct cable is used.  <b>Note:</b> If your Link LED is ON, you have connected using the correct type of cable, but it could still be defective.
	Wrong IP Address	Change the IP address of the module or the PC so that both match. Try the default module address of 128.1.1.100. For the PC NIC, try another address.
<i>Many Communication Errors.</i>	Is cable segment longer than 100M?	Maximum distance between two nodes is limited to 100 meters using approved cable.
	Correct Cable?	Shielded CAT-5/5E cable or equivalent is recommended.
	Missing earth ground connection.	Connect earth ground to TB3-33 GND terminal adjacent to power terminal.
<i>Cannot Browse Module.</i>	Your browser may be setup to use a proxy server for LAN communications.	Temporarily disable the use of a proxy server by your browser (see procedure of next page).

*If your problem still exists after checking your wiring and reviewing this information, or if other evidence points to another problem with the unit, an effective and convenient fault diagnosis method is to exchange the module with a known good unit. Acromag's Application Engineers can provide further technical assistance if required. Complete repair services are also available from Acromag.*

Please refer Acromag Application Note 8500-734 for help in setting up network communication with your module (located on the CDROM shipped with your module or via download from our web site at [www.acromag.com](http://www.acromag.com)). This document gives details for changing your PC's TCP/IP configuration in order to communicate with your module (see TCP/IP Properties of Network Configuration in Windows).

If you have carefully followed this procedure and you still cannot browse your module, you may have the web browser of your laptop or PC setup to use a proxy server when browsing the web. If you are using Internet Explorer, Refer to the "Tools" pulldown menu, select "Internet options...", click the "Connections" tab, then click the "LAN Settings" button. Locate the Proxy server information and uncheck the box next to the statement "Use a proxy server for your LAN". Then click [OK] to return to the "Connections" screen, and click [OK] again to save your settings.

You should now be able to use Internet Explorer to browse the module as required. However, to later restore your PC's connection to your company network, you may have to re-enable the use of a proxy server for your LAN.

There is no built-in error detection to prevent you from writing invalid values to a configuration register. As such, if you inadvertently write an invalid value to an internal register, you could cause the module to become inoperable under certain conditions. If this happens, in order to regain control of the module, the module can either be re-downloaded at the factory, or you can try restoring the module to its initial configuration by following this procedure:

#### **Procedure For Restoring any 9xxEN Module to its Initial Configuration**

1. While module power is OFF, press and hold the front-panel toggle switch in the default (DFT left) position.
2. While continuing to hold the toggle switch in the default position, apply power to the module.
3. After a few seconds, the Status LED will begin to blink quickly and you can release the default switch at this point. The module will continue to boot itself as it normally does. That is, the green RUN LED will blink for 1-10 seconds as the unit acquires its address, then remain ON for normal operation.
4. If the STATUS LED fails to blink rapidly after a few seconds and the RUN LED just blinks for a few moments as it normally does, then reinitializing the module has failed and you should try it again. This time, make sure that the DFT switch is completely depressed and held while powering the unit. Also make sure that you are pressing the DFT toggle in the DFT direction (left), rather than the RST direction (right).

## **TROUBLE-SHOOTING**

### **Trouble Browsing Your Module?**

### **Getting Out Of Trouble**

*So, you think your module's "gone wild", follow this procedure to restore it to its initial configuration and regain control.*

## TECHNICAL REFERENCE

### KEY FEATURES

- **Safety Agency Approvals** – CE, UL, & cUL listed, plus Class 1; Division 2; Groups A, B, C, D approval.
- **Fully Isolated** – Input channels (as a group), network, and power are all isolated from each other for safety and increased noise immunity.
- **EtherNet/IP Protocol Support** – Supports up to 10 connected messaging sessions, plus unconnected messaging. It also supports PCCC messaging for legacy support with Allen Bradley SLC5/05 PLC's.
- **Built-In Web Server** - Allows unit to optionally be configured, controlled, and monitored via access with a standard web browser over ethernet.
- **Modbus TCP/IP Protocol Support** – Supports 1 socket of Modbus TCP/IP using port number 502.
- **Flexible IP Addressing** – Supports static, DHCP, or BOOTP. Unit may also fall back to last DHCP IP address assignment.
- **Convenient “Wink” ID Mode Support** – Blinks green RUN LED in wink mode as a visual tool to help identify specific remote units on a network.
- **Fully Independent w/ Direct I/O Connection** – Self-contained with no special bus couplers, power supply, or rack mount required to operate.
- **Isolated Network Interface** – Immune to noise & can operate over long distances. Allows many modules to network together.
- **Network Port is Transient Protected** – Shielded RJ45 port includes transient protection from ESD, EFT, and other transients.
- **10Base-T and 100Base-TX Support** – Per IEEE 802.3/802.3u.
- **Auto-Negotiated 10/100Mbps, Half or Full Duplex.**
- **Flexible Multi-Range Analog Inputs** - Accepts either DC current or DC voltage, according to model number.
- **Range Variability** – The first 3 channels must share the same range, but this can be different than the range of the last 3 channels.
- **Optional AC Current Input (961EN Only)** - An optional AC current sensor can be purchased separately to support AC current inputs.
- **Precise High-Resolution A/D Conversion** – Modules use high-resolution, low noise, sigma-delta analog-to-digital conversion for high accuracy and reliability.
- **Plug-In Terminal Blocks & DIN-Rail Mount** - Make mounting, removal, and replacement easy.
- **Nonvolatile Reprogrammable Memory** – Allows the functionality of this device to be reliably reprogrammed thousands of times.
- **Operation/Diagnostic LED Indicators Aide Troubleshooting** – Yellow ACT LED indicates port activity (busy). Green LNK LED indicates link (auto-negotiation complete & connection established). Green RUN LED indicates power/wink ID mode. Yellow ST LED indicates module status.
- **Self-Diagnostics & Built In Watchdog** - For easy maintenance and troubleshooting. Includes a hardware watchdog timer built into the microcontroller that causes it to initiate a self reset if the controller ever “locks up” or fails to return from an operation in a timely manner.
- **Wide-Range DC-Power** – Wide range diode-coupled for use with redundant supplies, and/or battery back-up.
- **Hardened For Harsh Environments** - For protection from RFI, EMI, ESD, EFT, & surges. Has low radiated emissions per CE requirements.
- **Wide Ambient Operation** – Reliable over a wide temperature range.

## HOW IT WORKS

These input modules provide up to six process current (961EN), or six differential DC voltage (962EN) input channels, and provide an isolated 10/100 Ethernet interface for configuration, monitoring, and control of the input module. The current input model (961EN) uses precision 24.9Ω current sink resistors across the inputs. Voltage input models use 10:1 precision resistor voltage dividers at the input. A multiplexer is used to connect each input voltage to an A/D converter (separate A/D channels serve 3 input channels each). The A/D converter then applies appropriate gain to the signals, performs analog-to-digital conversion, and digitally filters the signals. The microcontroller completes the transfer function according to the input type and its embedded program. Configuration and calibration parameters are stored in non-volatile memory integrated within the microcontroller. A dedicated Ethernet controller handles Ethernet communication. The I/O terminals and the Ethernet port terminals also include transient suppression. A wide input switching regulator (isolated flyback) provides isolated power to the I/O circuits and the Ethernet controller. Refer to the simplified schematic shown below to help gain a better understanding of the circuit.

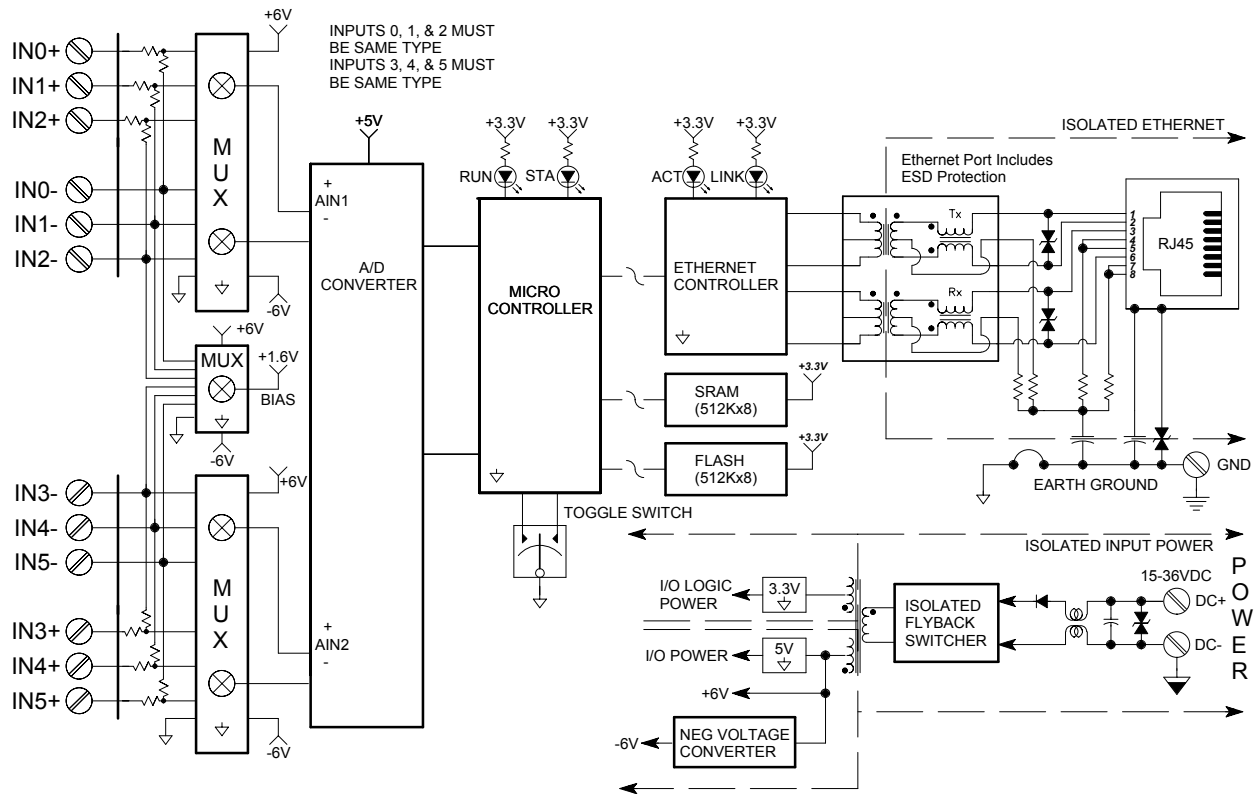

Note that input types may vary between the two channel groups—channel 0, 1, and 2 may be configured differently from channel 3, 4, and 5. Inputs are not isolated channel-to-channel, except for small common mode voltage differences in the range of ±5V (961EN), and ±12V (962EN).



## ETHERNET/IP

EtherNet/IP (Ethernet Industrial Protocol) is traditional Ethernet combined with an industrial application layer protocol targeted to industrial automation. This application layer protocol is the Control and Information Protocol (CIP™).

For more information on EtherNet/IP, please refer to our whitepaper "Introduction to EtherNet/IP", 8500-747. This document is included on the CDROM that came with your module and may also be downloaded from our web site at [www.acromag.com](http://www.acromag.com). You may also obtain a copy of the EtherNet/IP standard from the Open deviceNet Vendor association (ODVA) web site for EtherNet/IP at [www.ethernet-ip.org](http://www.ethernet-ip.org).

## Object Models

All CIP™ devices are modeled as a *collection of objects*. An object represents a particular component of a device. This collection of related data values and common elements of the device make up its *object model*. We use the term *class* to refer to a specific type or set of objects (same kind of system components), and *instance* to refer to one implementation of a *class*. The term *attribute* refers to a characteristic of an instance, an object, or an object class. *Attributes* provide status information and govern the operation of an object. *Services* are used to trigger the object/class to perform a task. And the object's response is referred to as its *behavior*. Note that the term *object* and *class* are often used interchangeably, even though a class is really a specific type of object.

To illustrate, if our object is fruit, we can say that an apple is a *class* of fruit. A Macintosh apple is an *instance* of this class, and red skin is one *attribute* of this particular instance.

In general, there are three types of objects or classes defined by CIP™—*required* objects, application or *device-specific* objects, and *vendor-specific* objects. Required objects must be included in every CIP™ device. Device-specific objects are the objects that define the data encapsulated by the device and are specific to the type of device and its function. Objects not found in the profile for a device class are vendor-specific objects and these vendor extensions are usually included as *additional features* of the device.

With CIP™, a class exists simply to combine data for I/O messaging among common elements and the CIP™ library already contains many commonly defined objects or classes. The confusion that surrounds this topic usually arises from the nesting of objects and classes that occurs in defining other objects and classes, and in linking together these various objects to build larger device *profiles*. This device's object model makes use of the following objects:

OBJECT (ID)	TYPE
Identity (01H)	Required
Message Router (02H)	Required
Assembly (04H)	Device-specific
Connection Manager (06H)	Required
TCP Object (F5H)	Required
Ethernet Link Object (F6H)	Required
PCCC Object (67H)	Device-specific
Discrete Output Data (71H)	Device-specific
Analog Input Data Object (80H)	Device-specific.



These objects combine to form the object model for the 961EN-6006 and 962EN-6006 and make use of the following data types:

## Object Models

DATA TYPE	DESCRIPTION
USINT	Unsigned Short Integer (8-bits)
UINT	Unsigned Integer (16-bits)
UDINT	Unsigned Double Integer (32-bits)
STRING	Character String w/ 1-byte per character
BYTE	8-bit String
WORD	16-bit String
DWORD	32-bit String

ATTR ID	NAME	DATA TYPE	DATA VALUE	Access RULE
<b>Class Attributes</b>				
1	Revision	UINT	1	GET
<b>Instance Attributes</b>				
1	Vendor Number	UINT	894 <sub>DEC</sub>	GET
2	Device Type 0x00 – Generic	UINT	00 <sub>HEX</sub>	GET
3	Product Code Number <sup>1</sup>	UINT	0F <sub>HEX</sub> (961EN) <sup>1</sup>	GET
4	Product Major Revision Product Minor Revision	USINT USINT	01 01	GET
5	Status Word (see definition below)	WORD	See Below	GET
6	Product Serial Number	UDINT	Unique 32 Bit Val	GET
7	Product Name <sup>2</sup> <b>Structure of:</b> Product Name Size Product Name String <sup>2</sup>	USINT USINT[0-32]	18 "Acromag 961EN-6006"	GET
<b>Status Word</b>				
<b>Bit</b>	<b>Bit = 0</b>	<b>Bit = 1</b>		
0	No I/O Connection	I/O Connection Allocated		
1-15	Unused	Unused		
<b>Common Services</b>				
<b>SVC CODE</b>	<b>IMPLEMENTED FOR</b>		<b>SERVICE NAME</b>	
	<b>CLASS LEVEL</b>	<b>INSTANCE LEVEL</b>		
0E <sub>HEX</sub>	Yes	Yes	Get_Attribute_Single	
05 <sub>HEX</sub>	No	Yes	Reset	
<b>Reset Service Code</b>				
<b>SVC CODE</b>	<b>CLASS</b>	<b>INSTANCE</b>	<b>ATTRIBUTE</b>	<b>DESCRIPTION</b>
05H	01H	01H	00H <sup>3</sup>	Force software reset.
05H	01H	01H	01H <sup>3</sup>	Reload factory settings and reset.

### Identity Object (01<sub>HEX</sub> - 1 Instance)

*This object provides identification of, and general information about the device.*

<sup>1</sup>Product Codes: 961EN=15 (0FH), or 962EN=1 (01H).

<sup>2</sup>Product Name: "Acromag 961EN-6006", or "Acromag 962EN-6006".

<sup>3</sup>Some software packages will require that the attribute field be left blank and this value entered in data field.

## Message Router Object (02<sub>HEX</sub>)

This object has no supported attributes.

*The message router object provides a messaging connection point through which a client may address a service to any object class or instance residing in the device.*

## Assembly Object (04<sub>HEX</sub> – 4 Instances)

*The Assembly Object binds attributes of multiple objects, allowing data to or from each object to be sent or received over a single connection.*

*Assembly objects can be used to bind input data or output data—note that “input” and “output” are taken from the network’s perspective. An input will produce data on the network while an output will consume data from the network.*

ATTR ID	NAME	DATA TYPE	DATA VALUE	ACCESS RULE
<b>Class Attributes</b>				
1	Revision	UINT	1	GET
2	Max Instance	UINT	81	GET
<b>Instance 64H Attributes (Input Instance 1)</b>				
3	Discrete Input Data (Array of Words)	UINT[ ]	0	GET
	Analog Input Data (Array of Words)	UINT[ ]	6	
<b>Instance 70H Attributes (Output Instance 1)</b>				
3	Discrete Output Data (Array of Words)	UINT[ ]	3 <sup>1</sup>	GET/SET
	Analog Output Data (Array of Words)	UINT[ ]	0	
<b>Instance 80H Attributes (Configuration Instance)</b>				
<i>Most I/O clients include a configuration path when opening an I/O connection to a server. There is no configuration data needed.</i>				
<b>Instance 81H Attributes (Heartbeat Instance – Input Only)</b>				
<i>This instance allows clients to monitor input data without providing output data.</i>				
<b>Common Services</b>				
SVC	IMPLEMENTED FOR			SERVICE NAME
CODE	CLASS LEVEL	INSTANCE LEVEL		
0E <sub>HEX</sub>	Yes	Yes		Get Attribute Single
10 <sub>HEX</sub>	No	Yes		Set Attribute Single

<sup>1</sup> See Discrete Output Data Object for a description of the functionality for this attribute.

## Connection Manager Object (06<sub>HEX</sub>)

This object has no attributes.

*This object is used for connection and connectionless communication, including establishing connections across multiple subnets.*

**TCP/IP Interface Object  
(F5<sub>HEX</sub> – 1 Instance)**

ATTR ID	NAME	DATA TYPE	DATA VALUE	ACCESS RULE
<b>Class Attributes</b>				
1	Revision	UINT	1	GET
<b>Instance</b>				
1	Status <sup>1</sup>	DWORD	1	GET
2	Configuration Capability <sup>2</sup>	UINT[]	5	GET
3	Configuration Control <sup>3</sup>		0	GET
4	Physical Link Object <sup>4</sup> - A Structure Of:			GET
	Path Size	UINT	2	
	Path	Array of WORD	20F6H.. 2401H	
5	Interface Configuration <sup>5</sup> A Structure Of:			GET
	IP Address	UDINT	0	
	Network Mask	UDINT	0	
	Gateway Address	UDINT	0	
	Name Server	UDINT	0	
	Name Server 2	UDINT	0	
	Domain Name Size	UINT	0	
Domain Name	STRING	0		
6	Host Name <sup>6</sup> - A Structure Of:			GET
	Host Name Size	UINT	0	
	Host Name	STRING	0	
<b>Common Services</b>				
<b>SVC CODE</b>	<b>IMPLEMENTED FOR</b>		<b>SERVICE NAME</b>	
	<b>CLASS LEVEL</b>	<b>INSTANCE LEVEL</b>		
0E <sub>HEX</sub>	Yes	Yes	Get Attribute Single	
10 <sub>HEX</sub>	No	Yes	Set Attribute Single	

<sup>1</sup> See section 5-3.2.2.1 of "Volume 2: EtherNet/IP Adaptation of CIP™" from ODVA for more details on this attribute.

<sup>2</sup> See section 5-3.2.2.2 of "Volume 2: EtherNet/IP Adaptation of CIP™" from ODVA for more details on this attribute.

<sup>3</sup> See section 5-3.2.2.3 of "Volume 2: EtherNet/IP Adaptation of CIP™" from ODVA for more details on this attribute.

<sup>4</sup> See section 5-3.2.2.4 of "Volume 2: EtherNet/IP Adaptation of CIP™" from ODVA for more details on this attribute.

<sup>5</sup> See section 5-3.2.2.5 of "Volume 2: EtherNet/IP Adaptation of CIP™" from ODVA for more details on this attribute.

<sup>6</sup> See section 5-3.2.2.6 of "Volume 2: EtherNet/IP Adaptation of CIP™" from ODVA for more details on this attribute.

### EtherNet Link Object (F6<sub>HEX</sub> – 1 Instance)

ATTR ID	NAME	DATA TYPE	DATA VALUE	ACCESS RULE
<b>Class Attributes</b>				
1	Revision	UINT	1	GET
<b>Instance Attributes</b>				
1	Interface Speed <sup>1</sup>	UDINT	100 (default)	GET
2	Interface Flags <sup>2</sup>	DWORD	3 (default)	GET
3	Physical Address <sup>3</sup>	USINT Array[6]	0 (default)	GET
<b>Common Services</b>				
<b>SVC</b>	<b>IMPLEMENTED FOR</b>			<b>SERVICE NAME</b>
<b>CODE</b>	<b>CLASS LEVEL</b>	<b>INSTANCE LEVEL</b>		
0E <sub>HEX</sub>	Yes	Yes		Get_Attribute_Single

<sup>1</sup>See section 5-4.2.2.2 of "Volume 2: EtherNet/IP Adaptation of CIP™" from ODVA for more details on this attribute.

<sup>2</sup>See section 5-4.2.2.1 of "Volume 2: EtherNet/IP Adaptation of CIP™" from ODVA for more details on this attribute.

<sup>3</sup>See section 5-4.2.2.3 of "Volume 2: EtherNet/IP Adaptation of CIP™" from ODVA for more details on this attribute.

### Analog Input Data Object (80<sub>HEX</sub> – 1 Instance)

ATTR ID	NAME	DATA TYPE	DATA VALUE	ACCESS RULE
<b>Class Attributes</b>				
1	Revision	UINT	1	GET
<b>Instance Attributes</b>				
1	Number of Analog Input Words	UINT	6	GET
3	Analog Input Data <sup>1</sup>	UINT[ ]	0	GET
5	Analog Input Status <sup>2</sup>	UINT[6]	0	GET
6	Port 0 Range <sup>3</sup>	UINT	0	GET/SET
7	Port 1 Range <sup>3</sup>	UINT	0	GET/SET
<b>Common Services</b>				
<b>SVC</b>	<b>IMPLEMENTED FOR</b>			<b>SERVICE NAME</b>
<b>CODE</b>	<b>CLASS LEVEL</b>	<b>INSTANCE LEVEL</b>		
0E <sub>HEX</sub>	Yes	Yes		Get_Attribute_Single
10 <sub>HEX</sub>	No	Yes		Set_Attribute_Single

<sup>1</sup>**Data Values:** 20000=Upper endpoint of range, -20000=Lower endpoint of range.

<sup>2</sup>**Status Values:** 0=IN range, 1=OVER range, 2=UNDER range.

<sup>3</sup>**Port Range:** Port 0=CH0+CH1+CH2, Port 1=CH3+CH4+CH5. Range Values (961EN): 0=0-20mA DC, 1=4-20mA DC, 2=0-11.17mA DC, 3=0-1mA DC. Range Values (962EN): 0=±10.000 VDC, 1=±5.000 VDC, 2=±2.500 VDC, 3 = ±1250mVDC, 4 = ±625mVDC, 5 = ±313mVDC, 6 = ±156mVDC, 7 = ±78mVDC.

ATTR ID	NAME	DATA TYPE	DATA VALUE	ACCESS RULE
<b>Class Attributes – NONE</b>				
<b>Instance Attributes – NONE</b>				
<b>Common Services</b>				
SVC	IMPLEMENTED FOR		SERVICE NAME	
CODE	CLASS LEVEL	INSTANCE LEVEL		
4B <sub>HEX</sub>	No	Yes	Execute PCCC Request	
Execute PCCC Request (Service Code 4BH) – Allen Bradley (AB) and Rockwell Automation (RA) devices use the “Execute PCCC Request” service code to communicate with their legacy products like the PLC5E and SLC5/05. This product emulates a PLC5E, thus enabling communication to legacy AB/RA devices.				
<b>PCCC Mapping (READ ONLY Parameters)</b>				
REG 16-bit Word	OBJECT MODEL LOCATION			DESCRIPTION
	Class	Instance	Attribute	
N7:0	71H	01H	01H	Number of discrete output words.
N7:1	80H	01H	01H	Number of analog input words.
N7:2	80H	01H	03H	Analog Input Data[0] <sup>1</sup>
N7:3	80H	01H	03H	Analog Input Data[1] <sup>1</sup>
N7:4	80H	01H	03H	Analog Input Data[2] <sup>1</sup>
N7:5	80H	01H	03H	Analog Input Data[3] <sup>1</sup>
N7:6	80H	01H	03H	Analog Input Data[4] <sup>1</sup>
N7:7	80H	01H	03H	Analog Input Data[5] <sup>1</sup>
N7:8	80H	01H	05H	Analog Input Status[0] <sup>2</sup>
N7:9	80H	01H	05H	Analog Input Status[1] <sup>2</sup>
N7:10	80H	01H	05H	Analog Input Status[2] <sup>2</sup>
N7:11	80H	01H	05H	Analog Input Status[3] <sup>2</sup>
N7:12	80H	01H	05H	Analog Input Status[4] <sup>2</sup>
N7:13	80H	01H	05H	Analog Input Status[5] <sup>2</sup>
N7:14	80H	01H	07H	Port 0 Range <sup>3</sup> .
N7:15	80H	01H	08H	Port 1 Range <sup>3</sup> .
<b>PCCC Mapping (READ/WRITE Parameters)</b>				
REG Integer	OBJECT MODEL LOCATION			DESCRIPTION
	Class	Instance	Attribute	
N14:0	71H	01H	03H	<sup>4</sup> Discrete Output Data[0] (Utility – See Below)
N14:1	71H	01H	03H	<sup>4</sup> Discrete Output Data[1] (Span Calibration)
N14:2	71H	01H	03H	<sup>4</sup> Discrete Output Data[2] (Zero Calibration)
N14:3	80H	01H	07H	Port 0 Range <sup>3</sup>
N14:4	80H	01H	08H	Port 1 Range <sup>3</sup>

**PCCC Object  
(67<sub>HEX</sub> - 1 Instance)**

For more information on how to set up a message command to Acromag 9xxEN modules using ladder logic programming with the SLC 5/05, please refer to Acromag Application Note 8500-761, titled “Communicating to Acromag Series 9xxEN-60xx Ethernet Modules from Legacy Allen Bradley or Rockwell Automation Devices”.

**PCCC Object  
(67<sub>HEX</sub> - 1 Instance)**

<sup>1</sup> **Analog Input Data** - A 16-bit signed integer in range of -32768 to +32767, with ±20000 used to represent ±100%. Resolution is 0.005%/lsb. For example, -100%, 0% & +100% are represented by decimal value -20000, 0, & 20000, respectively. Full range is -163.84% (-32768) to +163.835% (+32767).

<sup>2</sup> **Analog Input Status:** 0=IN range, 1=OVER range, 2=UNDER range.

<sup>3</sup> **Port Range:** The range setting for all channels of the port as follows:

RANGE	961EN-6006	962EN-6006
0	0-20mA	±10V
1	4-20mA	±5V
2	0-11.17mA	±2.5V
3	0-1mA	±1250mV
4	NA	±625mV
5	NA	±313mV
6	NA	±156mV
7	NA	±78mV

<sup>4</sup> **Discrete Output Data Functions:** The 961EN-6006 and 962EN-6006 do not have physical digital outputs, but utilize the digital output data to trigger field calibration of the unit, invoke the “wink” function, and restore factory calibration as follows:

- Data[0] = 5555H = Wink/Stop Wink Toggle
- Data[0] = AEAEH = Restore Factory Calibration
- Data[0] = 5E2AH = Unlock Calibration
- Data[0] = 0000H = Lock Calibration
- Data[1] = Span Calibration & Channel
- Data[2] = Zero Calibration & Channel

Writing 21845 (5555H) to Data[0] will cause the module to “wink” its Run LED. Writing this value a second time will stop “wink” (Toggles wink ON/OFF).

Writing 44718 (AEAEH) to Data[0] will cause the module to restore its factory calibration. Note that this can only be done after a “Save Factory Calibration” has been done at the factory.

Before field calibration can take place, write a value of 24106 (5E2AH) to Discrete Output Data[0] (Calibration Unlock) to immediately remove write protection from the calibration registers. Write 0 to apply write protection to the calibration registers. Always be sure to set this value back to 0 when finished calibrating to prevent inadvertent calibration.

Note that the bit positions of Data[1] and Data[2] indicate the channel to be calibrated for span and zero respectively. For example, if you wanted to calibrate channel 0 span, write 0001H to the Data[1] (Span Calibration Word). If you wanted to calibrate channel 5 zero, write 0020H to the data[2] (Zero Calibration Word).

If you would like more information on using the PCCC Object, please visit our web site at [www.acromag.com](http://www.acromag.com) and download application note 8500-761, titled “Communicating to Acromag Series 9xxEN-60xx Ethernet Modules from Legacy Allen Bradley or Rockwell Automation Devices”. This note was written to show users with a working knowledge of the SLC 5/05, how to set up a message command to Acromag 9xxEN modules using ladder logic programming.

ATTR ID	NAME	DATA TYPE	DATA VALUE	ACCESS RULE
<b>Class Attributes</b>				
1	Revision	UINT	1	GET
<b>Instance Attributes</b>				
1	Number of Discrete Output Words	UINT	3	GET
3	Discrete Output Data <sup>1</sup>	UINT[ ]	0	GET/SET
<b>Common Services</b>				
SVC	IMPLEMENTED FOR		SERVICE NAME	
CODE	CLASS LEVEL	INSTANCE LEVEL		
0E <sub>HEX</sub>	Yes	Yes	Get_Attribute_Single	
10 <sub>HEX</sub>	No	Yes	Set_Attribute_Single	

**Discrete Output Data Object**  
(71<sub>HEX</sub> – 1 Instance)

<sup>1</sup> **Discrete Output Data Functions:** The 961EN-6006 and 962EN-6006 do not have physical digital outputs, but utilize the digital output data to trigger field calibration of the unit, invoke the “wink” function, and restore factory calibration as follows:

Data[0] = 5555H = Wink/Stop Wink Toggle  
 Data[0] = AEAEH = Restore Factory Calibration  
 Data[0] = 5E2AH = Unlock Calibration  
 Data[0] = 0000H = Lock Calibration  
 Data[1] = Span Calibration & Channel  
 Data[2] = Zero Calibration & Channel

Writing 21845 (5555H) to Data[0] will cause the module to “wink” its Run LED. Writing this value a second time will stop “wink” (Toggles wink ON/OFF).

Writing 44718 (AEA EH) to Data[0] will cause the module to restore its factory calibration. Note that this can only be done after a “Save Factory Calibration” has been done at the factory.

Before field calibration can take place, write a value of 24106 (5E2AH) to Discrete Output Data[0] (Calibration Unlock) to immediately remove write protection from the calibration registers. Write 0 to apply write protection to the calibration registers. Always be sure to set this value back to 0 when finished calibrating to prevent inadvertent calibration.

Note that the bit positions of Data[1] and Data[2] indicate the channel to be calibrated for span and zero respectively. For example, if you wanted to calibrate channel 0 span, write 0001H to the Data[1] (Span Calibration Word). If you wanted to calibrate channel 5 zero, write 0020H to the data[2] (Zero Calibration Word).



## EDS File (Electronic Data Sheet)

The EDS file is an ASCII text file that describes a product's device type, product revision, and its configurable parameters on a network. EDS files contain file revision information (File), identity object information (Device), device type information - DeviceNet, EtherNet/IP or ControlNet (Device Classification), physical connection information (Port), and connection information (Connection Manager). EDS files may optionally contain parameter information used to configure specific attributes (Parameter), group information used to logically group parameters together (Group), or enumeration information used to assign meaningful names to values (Enum), plus other information as necessary.

All EtherNet/IP devices include an Electronic Data Sheet (EDS) file for device configuration. The purpose of this file is for use by various control software, network configuration tools, and application programs to help identify and understand the capabilities of the EtherNet/IP device, usually in order to commission it on an EtherNet/IP network. The EDS files of the 961EN-6006 (961eneip.eds) and 962EN-6006 (962eneip.eds) are shown below for reference (files are included on the CDROM that came with this equipment):

### Model 961EN-6006 (961ENEIP.EDS):

```
[File]
  DescText = "Acromag 961EN-6006 Analog Input
Module";
  CreateDate = 11-8-2004;
  CreateTime = 08:52:00;
  Revision = 1.0;
[Device]
  VendCode = 894;
  VendName = "Acromag Inc";
  ProdType = 0x00;
  ProdTypeStr = "Generic";
  ProdCode = 15;
  MajRev = 1;
  MinRev = 1;
  ProdName = "Acromag 961EN-6006";
[Device Classification]
  Class1 = EtherNetIP;
[Port]
  Port1 =
    TCP,
    "EtherNet/IP Port",
    "20 F5 24 01",
    1;
[Connection Manager]
  Connection1 =
    0x84010002, $ TRIGGER AND TRANSPORT MASK
    $ BIT=VAL DESCRIPTION
    $ 0 = 0 (class 0:null)
    $ 1 = 1 (class 1:dup. detect)
    $ 2 = 0 (class 2:acknowledged)
    $ 3 = 0 (class 3:verified)
    $ 4 = 0 (class 4:non-block)
    $ 5 = 0 (class 5:non-block, frag)
    $ 6 = 0 (class 6:multicast, frag)
    $ 7-15 = 0 (class :reserved)
    $ 16 = 1 (trigger: cyclic)
    $ 17 = 0 (trigger: cos)
    $ 18 = 0 (trigger: appl)
    $ 19-23 = 0 (trigger: reserved (must be zero))
    $ 24 = 0 (transport type: listen-only)
    $ 25 = 0 (transport type: input-only)
```

### Model 961EN-6006 (961ENEIP.EDS)...continued:

```

    $ 26 = 1 (transport type: exclusive-owner)
    $ 27 = 0 (transport type: redundant-owner)
    $ 28-30 = 0 (reserved (must be zero))
    $ 31 = 1 (client = 0 / server = 1)
    0x44240405, $ CONNECTION PARAMETERS BIT
ASSIGNMENTS
    $ BIT=VAL DESCRIPTION
    $ 0 = 1 (O=>T fixed)
    $ 1 = 0 (O=>T variable)
    $ 2 = 1 (T=>O fixed)
    $ 3 = 0 (T=>O variable)
    $ 4-7 = 0 (reserved (must be zero))
    $ 8-10 = 4 (O=>T header (4 byte run/idle))
    $ 11 = 0 (reserved (must be zero))
    $ 12-14 = 0 (T=>O header (pure data))
    $ 15 = 0 (reserved (must be zero))
    $ 16 = 0 (O=>T connection type: NULL)
    $ 17 = 0 (O=>T connection type: MULTI)
    $ 18 = 1 (O=>T connection type: P2P)
    $ 19 = 0 (O=>T connection type: RSVD)
    $ 20 = 0 (T=>O connection type: NULL)
    $ 21 = 1 (T=>O connection type: MULTI)
    $ 22 = 0 (T=>O connection type: P2P)
    $ 23 = 0 (T=>O connection type: RSVD)
    $ 24 = 0 (O=>T priority: LOW)
    $ 25 = 0 (O=>T priority: HIGH)
    $ 26 = 1 (O=>T priority: SCHEDULED)
    $ 27 = 0 (O=>T priority: RSVD)
    $ 28 = 0 (T=>O priority: LOW)
    $ 29 = 0 (T=>O priority: HIGH)
    $ 30 = 1 (T=>O priority: SCHEDULED)
    $ 31 = 0 (T=>O priority: RSVD)
    ,12,, $ O=>T RPI, size in bytes, format (6 (Output Data)
+ 4 (Run/Idle) + 2 (PDU Sequence Number))
    ,14,, $ T=>O RPI, size in bytes, format ( 12(Input Data)
+ 2 (PDU Sequence Number))
    ,, $ config part 1 (dynamic assemblies)
    ,, $ config part 2 (module configuration)
    "961EN", $ connection name
    "", $ Help string
    "20 04 24 80 2C 70 2C 64"; $ exclusive owner path
```

Model 962EN-6006 (962ENEIP.EDS):

```
[File]
  DescText = "Acromag 962EN-6006 Analog Input
Module";
  CreateDate = 11-8-2004;
  CreateTime = 08:54:00;
  Revision = 1.0;
```

```
[Device]
  VendCode = 894;
  VendName = "Acromag Inc";
  ProdType = 0x00;
  ProdTypeStr = "Generic";
  ProdCode = 1;
  MajRev = 1;
  MinRev = 1;
  ProdName = "Acromag 962EN-6006";
```

```
[Device Classification]
  Class1 = EtherNetIP;
```

```
[Port]
  Port1 =
    TCP,
    "EtherNet/IP Port",
    "20 F5 24 01",
    1;
```

```
[Connection Manager]
  Connection1 =
    0x84010002, $ TRIGGER AND TRANSPORT MASK
    $ BIT=VAL DESCRIPTION
    $ 0 = 0 (class 0:null)
    $ 1 = 1 (class 1:dup. detect)
    $ 2 = 0 (class 2:acknowledged)
    $ 3 = 0 (class 3:verified)
    $ 4 = 0 (class 4:non-block)
    $ 5 = 0 (class 5:non-block, frag)
    $ 6 = 0 (class 6:multicast, frag)
    $ 7-15 = 0 (class :reserved)
    $ 16 = 1 (trigger: cyclic)
    $ 17 = 0 (trigger: cos)
    $ 18 = 0 (trigger: appl)
    $ 19-23 = 0 (trigger: reserved (must be zero))
    $ 24 = 0 (transport type: listen-only)
    $ 25 = 0 (transport type: input-only)
    $ 26 = 1 (transport type: exclusive-owner)
    $ 27 = 0 (transport type: redundant-owner)
    $ 28-30 = 0 (reserved (must be zero))
    $ 31 = 1 (client = 0 / server = 1)
    0x44240405, $ CONNECTION PARAMETERS BIT
ASSIGNMENTS
    $ BIT=VAL DESCRIPTION
    $ 0 = 1 (O=>T fixed)
    $ 1 = 0 (O=>T variable)
    $ 2 = 1 (T=>O fixed)
    $ 3 = 0 (T=>O variable)
    $ 4-7 = 0 (reserved (must be zero))
    $ 8-10 = 4 (O=>T header (4 byte run/idle))
    $ 11 = 0 (reserved (must be zero))
    $ 12-14 = 0 (T=>O header (pure data))
    $ 15 = 0 (reserved (must be zero))
    $ 16 = 0 (O=>T connection type: NULL)
    $ 17 = 0 (O=>T connection type: MULTI)
    $ 18 = 1 (O=>T connection type: P2P)
    $ 19 = 0 (O=>T connection type: RSVD)
    $ 20 = 0 (T=>O connection type: NULL)
```

Model 962EN-6006 (962ENEIP.EDS)...continued:

```

$ 21 = 1 (T=>O connection type: MULTI)
$ 22 = 0 (T=>O connection type: P2P)
$ 23 = 0 (T=>O connection type: RSVD)
$ 24 = 0 (O=>T priority: LOW)
$ 25 = 0 (O=>T priority: HIGH)
$ 26 = 1 (O=>T priority: SCHEDULED)
$ 27 = 0 (O=>T priority: RSVD)
$ 28 = 0 (T=>O priority: LOW)
$ 29 = 0 (T=>O priority: HIGH)
$ 30 = 1 (T=>O priority: SCHEDULED)
$ 31 = 0 (T=>O priority: RSVD)
,12,, $ O=>T RPI, size in bytes, format (6 (Output Data)
+ 4 (Run/Idle) + 2 (PDU Sequence Number))
,14,, $ T=>O RPI, size in bytes, format ( 12(Input Data)
+ 2 (PDU Sequence Number))
,, $ config part 1 (dynamic assemblies)
,, $ config part 2 (module configuration)
"962EN", $ connection name
"", $ Help string
"20 04 24 80 2C 70 2C 64"; $ exclusive owner path
```

## MODBUS TCP/IP

Although this module is designed primarily for EtherNet/IP operation, this model also provides one socket for Modbus TCP/IP applications. Its Modbus operation is identical to that of the 961/962EN-4006 models, but restricted to a single socket. For complete coverage of Modbus TCP/IP, you may refer to the information contained within User's Manual 8500-720, or the Modbus TCP/IP version of this module (961EN-4006 & 962EN-4006). The Modbus memory map is repeated here for your convenience. All program parameters outlined in the Modbus memory map are also available in the EtherNet/IP object model. You may find it helpful to refer to the memory map for explanations on the program parameters encountered in the object model.

### Modbus Registers

Modbus registers are organized into reference types identified by the leading number of the reference address:

*The "x" following the leading character represents a four-digit address location in user data memory.*

*The leading character is generally implied by the function code and omitted from the address specifier for a given function. The leading character also identifies the I/O data type.*

Reference	Description
0xxxx	<u>Read/Write Discrete Outputs or Coils</u> . A 0x reference address is used to drive output data to a digital output channel.
1xxxx	<u>Read Discrete Inputs</u> . The ON/OFF status of a 1x reference address is controlled by the corresponding digital input channel.
3xxxx	<u>Read Input Registers</u> . A 3x reference register contains a 16-bit number received from an external source—e.g. an analog signal.
4xxxx	<u>Read/Write Output or Holding Registers</u> . A 4x register is used to store 16-bits of numerical data (binary or decimal), or to send the data from the CPU to an output channel.

**Note:** The ON/OFF state of discrete inputs and outputs is represented by a 1 or 0 value assigned to an individual bit in a 16-bit data word. This is sixteen 0x or 1x references per data word. With respect to mapping, the LSB of the word maps to the lowest numbered channel of a group and channel numbers increase sequentially as you move towards the MSB. Unused bit positions are set to zero.

All I/O values are accessed via the 16-bit Input or Holding Registers given in the Register Map. Input registers contain read-only information. For example, the current input value read from a channel, or the states of a group of digital inputs. Holding registers contain read/write information that may be configuration data or output data. For example, the high limit value of an alarm operating at an input, or an output value for an output channel.

### Register Functions

Each module has a default factory configuration as noted in the SPECIFICATIONS section. Your application will likely differ from the default configuration and the module will need to be reconfigured. You may reconfigure this module by issuing the appropriate Modbus functions to Register Map registers, as required by your application. You may also use a standard web browser to access the built-in web pages of the module to perform basic operations.

Below is a subset of standard Modbus functions that are supported by this module along with the reference register addresses that the function operates on. Use these functions to access these registers as outlined in the Register Map for sending and retrieving data.

## Register Functions

The following Modbus functions operate on register map registers to monitor, configure, and control module I/O:

CODE	FUNCTION	REFERENCE
01 (01H)	Read Coil (Output) Status	0xxxx
02 (02H)	Read Input Status	1xxxx
03 (03H)	Read Holding Registers	4xxxx
04 (04H)	Read Input Registers	3xxxx
05 (05H)	Force Single Coil (Output)	0xxxx
06 (06H)	Preset Single Register	4xxxx
15 (0FH)	Force Multiple Coils (Outputs)	0xxxx
16 (10H)	Preset Multiple Registers	4xxxx
17 (11H)	Report Slave ID (See Below)	<i>Hidden</i>

If an unsupported function code is sent to a module, exception code 01 (Illegal Function) will be returned in the response. If a holding register is written with an invalid value, exception code 03 (Illegal Data Value) will be returned in the response message. You may refer to the Modbus specification for a complete list of possible error codes.

### 961EN-6006 Report Slave ID Example Response

FIELD	DESCRIPTION
Unit ID	Echo Unit ID Sent In Query
Function Code	11
Byte Count	42
Slave ID (Model No.)	00=961EN-6006 (6 Differential Current Input) 01=962EN-6006 (6 Differential Voltage Input)
Run Indicator Status	FFH (ON)
Firmware Number String (Additional Data Field)	41 43 52 4F 4D 41 47 2C 39 33 30 30 2D <b>31 34 30</b> 2C 39 <b>36 31</b> 45 4E 2D <b>36 30 30 36</b> 2C 30 31 32 33 34 35 41 2C 30 31 32 33 34 35 (“ACROMAG,9300- <b>140</b> , <b>961EN-6006</b> ,serial number&rev,six-byteMACID”)

For detailed information on Modbus, feel free to download our technical reference “Introduction To Modbus” at [www.acromag.com](http://www.acromag.com).

For your convenience, 9xxEN Ethernet modules mirror the contents and operation of registers 0xxxx, 1xxxx, & 3xxxx (as applicable) into holding register space for systems and controllers that cannot directly access registers 0xxxx, 1xxxx, & 3xxxx.

## Register Mirroring

All Modbus registers of this model can now be written to, or read from, using either the standard methods described in the Modbus specification, or through mapping (mirroring) to the Holding Registers. The registers are mapped as follows and specifics follow the mapping:

## Register Mirroring

0xxxx Coil Registers are mapped to 42xxx Holding Registers  
 1xxxx Input Status Registers are mapped to 41xxx Holding Registers  
 3xxxx Input Registers are mapped to 43xxx Holding Registers

For 3xxxx Input Registers, the format of the registers are identical and you only need to offset your address by 43000. For example: if you want to read Input Register 1 through the Holding Registers, you would use the "Read Holding Registers" function with an address of 43001.

For the 1xxxx Input Status Registers (where supported), the return data is reformatted to match the Holding Register format. For example: if you request the Input Status for 12 digital inputs, instead of getting 2 bytes returned with the first 12 bits representing the 12 digital inputs, you will get 12 separate words, each set to either 0000H (OFF), or FFFFH (ON).

For the 0xxxx Coil Registers (where supported), reads are handled in the same way as the 1xxxx Input Status Registers. You can also write to the coil registers by using the "Preset Single Register" function with an address offset of 42000. Setting the data to 0000H will turn the coil OFF, while setting the data to FF00H will turn the coil ON. Writing to multiple coils is not supported via register mirroring, you must use the "Write Multiple Coils" function for that.

Note that with respect to Acromag 9xxMB Modbus RTU modules, only 3xxxx Input Registers are mirrored into 4xxxx space, not Coil or Input Status registers as noted here for 9xxEN models.

## Data Types

I/O values for Series 900EN modules are represented by the following simple data types for temperature, percentage, and discrete on/off.

### Summary Of Data Types Used By 900EN Modules

Data Types	Description
Percentage (This Model)	A 16-bit signed integer value in range of -32768 to +32767. $\pm 20000$ is used to represent $\pm 100\%$ , yielding a resolution of 0.005%/lsb. For example, -100%, 0% and +100% are represented by decimal values -20000, 0, and 20000, respectively. The full range is -163.84% (-32768 decimal) to +163.835% (+32767 decimal).
Temperature	A 16-bit signed integer value with resolution of 0.1°C/lsb. For example, a value of 12059 is equivalent to 1205.9°C, a value of -187 equals -18.7°C. The maximum possible temperature range is -3276.8°C to +3276.7°C.
Count Value	A 16-bit signed integer in range of -32768 to +32767, or unsigned integer in range of 0 to 65535, representing an A/D or DAC count, time value, or frequency.
Discrete	A discrete value is generally indicated by a single bit of a 16-bit word. The bit number/position typically corresponds to the discrete channel number. Unless otherwise defined for outputs, a 1 bit means the corresponding output is closed or ON, a 0 bit means the output is open or OFF. For inputs, a value of 1 means the input is ON (Active low near 0V), while a value of 0 specifies the input is OFF or in its high state (usually >> 0V).

The following table outlines the register map for the Model 961EN-6006 and 962EN-6006 network input modules. The Modbus functions operate on these registers using the data types noted above (except for the Reset Slave and Report Slave ID functions). Unless otherwise noted, Holding Register values are maintained in flash memory and are non-volatile.

## Register Map

**Model 961EN-6006**  
**Model 962EN-6006**

Ref	Addr.	Description	Data Type/Format
<b>Input Registers (3x References, Read-Only)</b>			
30001	0000	Module Status	Bit 15: 0 (Not Used) Bit 14: Wink Mode Flag 1 = Wink Mode (Blinks Run LED for ID) 0 = Normal Operation (See Wink Module Register) Bit 13: Default Mode Flag 1 = Default Mode Indicator 0 = Not Default Mode Bits 12-0: 0 (Not Used)
30002	0001	Input Range (CH 0,1,2 )	Bits 15-4: 0 (Not Used) Bits <u>3,2,1,0:</u> <u>961EN</u> <u>962EN</u> 0000    0=0-20mA    0=±10V 0001    1=4-20mA    1=±5V 0010    2=0-11.17mA    2=±2.5V 0011    3=0-1mA    3=±1.25V 0100 <i>Reserved</i> 4=±625mV 0101 <i>Reserved</i> 5=±313mV 0110 <i>Reserved</i> 6=±156mV 0111 <i>Reserved</i> 7=±78mV 1000-1111 <i>Reserved</i>
30003	0002	Input Range (CH 3,4,5 )	<i>Format is same as Above.</i>
30004	0003	CH00 Status	Bits 15-2: 0 (Not Used) Bits 1,0: <u>Input Signal Status</u> 00    In Range 01    Over-Range 10    Under-Range 11    Not Used
30005	0004	CH01 Status	Bits 15-2: 0 (Not Used) Bits 1,0: <u>Input Signal Status</u> 00    In Range 01    Over-Range 10    Under-Range 11    Not Used
30006	0005	CH02 Status	Bits 15-2: 0 (Not Used) Bits 1,0: <u>Input Signal Status</u> 00    In Range 01    Over-Range 10    Under-Range 11    Not Used



## Register Map

Model 961EN-6006  
Model 962EN-6006

Ref	Addr.	Description	Data Type/Format																														
<b>Input Registers (3x References, Read-Only)</b>																																	
30007	0006	CH03 Status	Bits 15-2: 0 (Not Used) Bits 1,0: <u>Input Signal Status</u> 00 In Range 01 Over-Range 10 Under-Range 11 Not Used																														
30008	0007	CH04 Status	Bits 15-2: 0 (Not Used) Bits 1,0: <u>Input Signal Status</u> 00 In Range 01 Over-Range 10 Under-Range 11 Not Used																														
30009	0008	CH05 Status	Bits 15-2: 0 (Not Used) Bits 1,0: <u>Input Signal Status</u> 00 In Range 01 Over-Range 10 Under-Range 11 Not Used																														
30010	0009	CH00 Value	Percentage (%)																														
30011	000A	CH01 Value	Percentage (%)																														
30012	000B	CH02 Value	Percentage (%)																														
30013	000C	CH03 Value	Percentage (%)																														
30014	000D	CH04 Value	Percentage (%)																														
30015	000E	CH05 Value	Percentage (%)																														
30016	000F	CH00 Count	Raw A/D Count Value (See Note 2)																														
30017	0010	CH01 Count	Raw A/D Count Value (See Note 2)																														
30018	0011	CH02 Count	Raw A/D Count Value (See Note 2)																														
30019	0012	CH03 Count	Raw A/D Count Value (See Note 2)																														
30020	0013	CH04 Count	Raw A/D Count Value (See Note 2)																														
30021	0014	CH05 Count	Raw A/D Count Value (See Note 2)																														
<b>Holding Registers (4x References, Read/Write)</b>																																	
40001	0000	Input Range (CH 0,1,2 )	Bits 15-4: 0 (Not Used) Bits <u>3,2,1,0:</u> <table border="0"> <tr> <td></td> <td><u>961EN</u></td> <td><u>962EN</u></td> </tr> <tr> <td>0000</td> <td>0=0-20mA</td> <td>0=±10V</td> </tr> <tr> <td>0001</td> <td>1=4-20mA</td> <td>1=±5V</td> </tr> <tr> <td>0010</td> <td>2=0-11.17mA</td> <td>2=±2.5V</td> </tr> <tr> <td>0011</td> <td>3=0-1mA</td> <td>3=±1.25V</td> </tr> <tr> <td>0100</td> <td>Reserved</td> <td>4=±625mV</td> </tr> <tr> <td>0101</td> <td>Reserved</td> <td>5=±313mV</td> </tr> <tr> <td>0110</td> <td>Reserved</td> <td>6=±156mV</td> </tr> <tr> <td>0111</td> <td>Reserved</td> <td>7=±78mV</td> </tr> <tr> <td>1000-1111</td> <td>Reserved</td> <td></td> </tr> </table>		<u>961EN</u>	<u>962EN</u>	0000	0=0-20mA	0=±10V	0001	1=4-20mA	1=±5V	0010	2=0-11.17mA	2=±2.5V	0011	3=0-1mA	3=±1.25V	0100	Reserved	4=±625mV	0101	Reserved	5=±313mV	0110	Reserved	6=±156mV	0111	Reserved	7=±78mV	1000-1111	Reserved	
	<u>961EN</u>	<u>962EN</u>																															
0000	0=0-20mA	0=±10V																															
0001	1=4-20mA	1=±5V																															
0010	2=0-11.17mA	2=±2.5V																															
0011	3=0-1mA	3=±1.25V																															
0100	Reserved	4=±625mV																															
0101	Reserved	5=±313mV																															
0110	Reserved	6=±156mV																															
0111	Reserved	7=±78mV																															
1000-1111	Reserved																																
40002	0001	Input Range (CH 3,4,5 )	Format is same as Above.																														

**Note:** Changes to Holding Registers take effect immediately.



**Register Map**

**Model 961EN-6006**  
**Model 962EN-6006**

*Note: Changes to Holding Registers take effect immediately.*

Ref	Addr.	Description	Data Type/Format
<b>Holding Registers (4x References, Read/Write)</b>			
40003	0002	Reserved	Do Not Use
40004	0003	Reserved	Do Not Use
40005	0004	Reserved	Do Not Use
40006	0005	Reserved	Do Not Use
40007	0006	Reserved	Do Not Use
40008	0007	Port 0 Scaling Low	Reserved For Factory Use - Do Not Use
40009	0008	Reserved	Do Not Use
40010	0009	Port 0 Scaling High	Reserved For Factory Use - Do Not Use
40011	000A	Reserved	Do Not Use
40012	000B	Port 1 Scaling Low	Reserved For Factory Use - Do Not Use
40013	000C	Reserved	Do Not Use
40014	000D	Port 1 Scaling High	Reserved For Factory Use - Do Not Use
40015	000E	Reserved	Do Not Use
40016	000F	Reserved	Do Not Use
40017	0010	Reserved	Do Not Use
40018	0011	Reserved	Do Not Use
40019	0012	Reserved	Do Not Use
40020	0013	Reserved	Do Not Use
40021	0014	Calibration Access  And Wink Mode Toggle  And Restore Factory Calibration  And <b>Factory Use Only</b>  <i>This register is not maintained in flash.</i>	Writing 24106 (5E2AH) here immediately removes write protection from the calibration registers that follow. Write 0 to apply write protection to the calibration registers.  Writing 21845 (5555H) to this register will cause the module to "Wink" its Run LED. Writing this value a second time will stop "Wink" (Toggles Wink ON/OFF).  Writing 44718 (AEA EH) will cause the module to restore its factory calibration. This can only be done after "Save Factory Calibration" has been done at the factory.  Writing 43981 (ABCDH) is reserved for factory use. <b>This should not be performed by anyone else or operation will be degraded.</b>  This register always reads back 0. After a reset, this register is set back to 0 (write protection enabled and no wink).

## Register Map

### Model 961EN-6006 Model 962EN-6006

Shaded 4xxxx register entries  
are Read Only

Ref	Addr.	Description	Data Type/Format
<b>Holding Registers (4x References, Read/Write)</b>			
40022	0015	CH0 Cal Hi Range 0	Raw A/D Count Value (See Note 2). 0-20mA (961EN) or ±10V (962EN)
40023	0016	CH0 Cal Lo Range 0	Raw A/D Count Value (See Note 2). 0-20mA (961EN) or ±10V (962EN)
40024	0017	CH0 Cal Hi Range 1	Raw A/D Count Value (See Note 2). 4-20mA (961EN) or ±5V (962EN)
40025	0018	CH0 Cal Lo Range 1	Raw A/D Count Value (See Note 2). 4-20mA (961EN) or ±5V (962EN)
40026	0019	CH0 Cal Hi Range 2	Raw A/D Count Value (See Note 2). 0-11.17mA (961EN) or ±2.5V (962EN)
40027	001A	CH0 Cal Lo Range 2	Raw A/D Count Value (See Note 2). 0-11.17mA (961EN) or ±2.5V (962EN)
40028	001B	CH0 Cal Hi Range 3	Raw A/D Count Value (See Note 2). 0-1mA (961EN) or ±1.25V (962EN)
40029	001C	CH0 Cal Lo Range 3	Raw A/D Count Value (See Note 2). 0-1mA (961EN) or ±1.25V (962EN)
40030	001D	CH0 Cal Hi Range 4	Raw A/D Count Value (See Note 2). ±625mV (962EN)
40031	001E	CH0 Cal Lo Range 4	Raw A/D Count Value (See Note 2). ±625mV (962EN)
40032	001F	CH0 Cal Hi Range 5	Raw A/D Count Value (See Note 2). ±313mV (962EN)
40033	0020	CH0 Cal Lo Range 5	Raw A/D Count Value (See Note 2). ±313mV (962EN)
40034	0021	CH0 Cal Hi Range 6	Raw A/D Count Value (See Note 2). ±156mV (962EN)
40035	0022	CH0 Cal Lo Range 6	Raw A/D Count Value (See Note 2). ±156mV (962EN)
40036	0023	CH0 Cal Hi Range 7	Raw A/D Count Value (See Note 2). ±78mV (962EN)
40037	0024	CH0 Cal Lo Range 7	Raw A/D Count Value (See Note 2). ±78mV (962EN)
40038	0025	CH1 Cal Hi Range 0	Raw A/D Count Value (See Note 2). 0-20mA (961EN) or ±10V (962EN)
40039	0026	CH1 Cal Lo Range 0	Raw A/D Count Value (See Note 2). 0-20mA (961EN) or ±10V (962EN)
40040	0027	CH1 Cal Hi Range 1	Raw A/D Count Value (See Note 2). 4-20mA (961EN) or ±5V (962EN)
40041	0028	CH1 Cal Lo Range 1	Raw A/D Count Value (See Note 2). 4-20mA (961EN) or ±5V (962EN)
40042	0029	CH1 Cal Hi Range 2	Raw A/D Count Value (See Note 2). 0-11.17mA (961EN) or ±2.5V (962EN)
40043	002A	CH1 Cal Lo Range 2	Raw A/D Count Value (See Note 2). 0-11.17mA (961EN) or ±2.5V (962EN)
40044	002B	CH1 Cal Hi Range 3	Raw A/D Count Value (See Note 2). 0-1mA (961EN) or ±1.25V (962EN)
40045	002C	CH1 Cal Lo Range 3	Raw A/D Count Value (See Note 2). 0-1mA (961EN) or ±1.25V (962EN)
40046	002D	CH1 Cal Hi Range 4	Raw A/D Count Value (See Note 2). ±625mV (962EN)

Ref	Addr.	Description	Data Type/Format
<b>Holding Registers (4x References, Read/Write)</b>			
40047	002E	CH1 Cal Lo Range 4	Raw A/D Count Value (See Note 2). ±625mV (962EN)
40048	002F	CH1 Cal Hi Range 5	Raw A/D Count Value (See Note 2). ±313mV (962EN)
40049	0030	CH1 Cal Lo Range 5	Raw A/D Count Value (See Note 2). ±313mV (962EN)
40050	0031	CH1 Cal Hi Range 6	Raw A/D Count Value (See Note 2). ±156mV (962EN)
40051	0032	CH1 Cal Lo Range 6	Raw A/D Count Value (See Note 2). ±156mV (962EN)
40052	0033	CH1 Cal Hi Range 7	Raw A/D Count Value (See Note 2). ±78mV (962EN)
40053	0034	CH1 Cal Lo Range 7	Raw A/D Count Value (See Note 2). ±78mV (962EN)
40054	0035	CH2 Cal Hi Range 0	Raw A/D Count Value (See Note 2). 0-20mA (961EN) or ±10V (962EN)
40055	0036	CH2 Cal Lo Range 0	Raw A/D Count Value (See Note 2). 0-20mA (961EN) or ±10V (962EN)
40056	0037	CH2 Cal Hi Range 1	Raw A/D Count Value (See Note 2). 4-20mA (961EN) or ±5V (962EN)
40057	0038	CH2 Cal Lo Range 1	Raw A/D Count Value (See Note 2). 4-20mA (961EN) or ±5V (962EN)
40058	0039	CH2 Cal Hi Range 2	Raw A/D Count Value (See Note 2). 0-11.17mA (961EN) or ±2.5V (962EN)
40059	003A	CH2 Cal Lo Range 2	Raw A/D Count Value (See Note 2). 0-11.17mA (961EN) or ±2.5V (962EN)
40060	003B	CH2 Cal Hi Range 3	Raw A/D Count Value (See Note 2). 0-1mA (961EN) or ±1.25V (962EN)
40061	003C	CH2 Cal Lo Range 3	Raw A/D Count Value (See Note 2). 0-1mA (961EN) or ±1.25V (962EN)
40062	003D	CH2 Cal Hi Range 4	Raw A/D Count Value (See Note 2). ±625mV (962EN)
40063	003E	CH2 Cal Lo Range 4	Raw A/D Count Value (See Note 2). ±625mV (962EN)
40064	003F	CH2 Cal Hi Range 5	Raw A/D Count Value (See Note 2). ±313mV (962EN)
40065	0040	CH2 Cal Lo Range 5	Raw A/D Count Value (See Note 2). ±313mV (962EN)
40066	0041	CH2 Cal Hi Range 6	Raw A/D Count Value (See Note 2). ±156mV (962EN)
40067	0042	CH2 Cal Lo Range 6	Raw A/D Count Value (See Note 2). ±156mV (962EN)
40068	0043	CH2 Cal Hi Range 7	Raw A/D Count Value (See Note 2). ±78mV (962EN)
40069	0044	CH2 Cal Lo Range 7	Raw A/D Count Value (See Note 2). ±78mV (962EN)
40070	0045	CH3 Cal Hi Range 0	Raw A/D Count Value (See Note 2). 0-20mA (961EN) or ±10V (962EN)
40071	0046	CH3 Cal Lo Range 0	Raw A/D Count Value (See Note 2). 0-20mA (961EN) or ±10V (962EN)

## Register Map

**Model 961EN-6006**

**Model 962EN-6006**

*Shaded 4xxxx register entries are Read-Only.*

## Register Map

**Model 961EN-6006**  
**Model 962EN-6006**

*Shaded 4xxxx register entries  
 are Read-Only.*

Ref	Addr.	Description	Data Type/Format
<b>Holding Registers (4x References, Read/Write)</b>			
40072	0047	CH3 Cal Hi Range 1	Raw A/D Count Value (See Note 2). 4-20mA (961EN) or $\pm 5V$ (962EN)
40073	0048	CH3 Cal Lo Range 1	Raw A/D Count Value (See Note 2). 4-20mA (961EN) or $\pm 5V$ (962EN)
40074	0049	CH3 Cal Hi Range 2	Raw A/D Count Value (See Note 2). 0-11.17mA (961EN) or $\pm 2.5V$ (962EN)
40075	004A	CH3 Cal Lo Range 2	Raw A/D Count Value (See Note 2). 0-11.17mA (961EN) or $\pm 2.5V$ (962EN)
40076	004B	CH3 Cal Hi Range 3	Raw A/D Count Value (See Note 2). 0-1mA (961EN) or $\pm 1.25V$ (962EN)
40077	004C	CH3 Cal Lo Range 3	Raw A/D Count Value (See Note 2). 0-1mA (961EN) or $\pm 1.25V$ (962EN)
40078	004D	CH3 Cal Hi Range 4	Raw A/D Count Value (See Note 2). $\pm 625mV$ (962EN)
40079	004E	CH3 Cal Lo Range 4	Raw A/D Count Value (See Note 2). $\pm 625mV$ (962EN)
40080	004F	CH3 Cal Hi Range 5	Raw A/D Count Value (See Note 2). $\pm 313mV$ (962EN)
40081	0050	CH3 Cal Lo Range 5	Raw A/D Count Value (See Note 2). $\pm 313mV$ (962EN)
40082	0051	CH3 Cal Hi Range 6	Raw A/D Count Value (See Note 2). $\pm 156mV$ (962EN)
40083	0052	CH3 Cal Lo Range 6	Raw A/D Count Value (See Note 2). $\pm 156mV$ (962EN)
40084	0053	CH3 Cal Hi Range 7	Raw A/D Count Value (See Note 2). $\pm 78mV$ (962EN)
40085	0054	CH3 Cal Lo Range 7	Raw A/D Count Value (See Note 2). $\pm 78mV$ (962EN)
40086	0055	CH4 Cal Hi Range 0	Raw A/D Count Value (See Note 2). 0-20mA (961EN) or $\pm 10V$ (962EN)
40087	0056	CH4 Cal Lo Range 0	Raw A/D Count Value (See Note 2). 0-20mA (961EN) or $\pm 10V$ (962EN)
40088	0057	CH4 Cal Hi Range 1	Raw A/D Count Value (See Note 2). 4-20mA (961EN) or $\pm 5V$ (962EN)
40089	0058	CH4 Cal Lo Range 1	Raw A/D Count Value (See Note 2). 4-20mA (961EN) or $\pm 5V$ (962EN)
40090	0059	CH4 Cal Hi Range 2	Raw A/D Count Value (See Note 2). 0-11.17mA (961EN) or $\pm 2.5V$ (962EN)
40091	005A	CH4 Cal Lo Range 2	Raw A/D Count Value (See Note 2). 0-11.17mA (961EN) or $\pm 2.5V$ (962EN)
40092	005B	CH4 Cal Hi Range 3	Raw A/D Count Value (See Note 2). 0-1mA (961EN) or $\pm 1.25V$ (962EN)
40093	005C	CH4 Cal Lo Range 3	Raw A/D Count Value (See Note 2). 0-1mA (961EN) or $\pm 1.25V$ (962EN)
40094	005D	CH4 Cal Hi Range 4	Raw A/D Count Value (See Note 2). $\pm 625mV$ (962EN)
40095	005E	CH4 Cal Lo Range 4	Raw A/D Count Value (See Note 2). $\pm 625mV$ (962EN)

Ref	Addr.	Description	Data Type/Format
<b>Holding Registers (4x References, Read/Write)</b>			
40096	005F	CH4 Cal Hi Range 5	Raw A/D Count Value (See Note 2). ±313mV (962EN)
40097	0060	CH4 Cal Lo Range 5	Raw A/D Count Value (See Note 2). ±313mV (962EN)
40098	0061	CH4 Cal Hi Range 6	Raw A/D Count Value (See Note 2). ±156mV (962EN)
40099	0062	CH4 Cal Lo Range 6	Raw A/D Count Value (See Note 2). ±156mV (962EN)
40100	0063	CH4 Cal Hi Range 7	Raw A/D Count Value (See Note 2). ±78mV (962EN)
40101	0064	CH4 Cal Lo Range 7	Raw A/D Count Value (See Note 2). ±78mV (962EN)
40102	0065	CH5 Cal Hi Range 0	Raw A/D Count Value (See Note 2). 0-20mA (961EN) or ±10V (962EN)
40103	0066	CH5 Cal Lo Range 0	Raw A/D Count Value (See Note 2). 0-20mA (961EN) or ±10V (962EN)
40104	0067	CH5 Cal Hi Range 1	Raw A/D Count Value (See Note 2). 4-20mA (961EN) or ±5V (962EN)
40105	0068	CH5 Cal Lo Range 1	Raw A/D Count Value (See Note 2). 4-20mA (961EN) or ±5V (962EN)
40106	0069	CH5 Cal Hi Range 2	Raw A/D Count Value (See Note 2). 0-11.17mA (961EN) or ±2.5V (962EN)
40107	006A	CH5 Cal Lo Range 2	Raw A/D Count Value (See Note 2). 0-11.17mA (961EN) or ±2.5V (962EN)
40108	006B	CH5 Cal Hi Range 3	Raw A/D Count Value (See Note 2). 0-1mA (961EN) or ±1.25V (962EN)
40109	006C	CH5 Cal Lo Range 3	Raw A/D Count Value (See Note 2). 0-1mA (961EN) or ±1.25V (962EN)
40110	006D	CH5 Cal Hi Range 4	Raw A/D Count Value (See Note 2). ±625mV (962EN)
40111	006E	CH5 Cal Lo Range 4	Raw A/D Count Value (See Note 2). ±625mV (962EN)
40112	006F	CH5 Cal Hi Range 5	Raw A/D Count Value (See Note 2). ±313mV (962EN)
40113	0070	CH5 Cal Lo Range 5	Raw A/D Count Value (See Note 2). ±313mV (962EN)
40114	0071	CH5 Cal Hi Range 6	Raw A/D Count Value (See Note 2). ±156mV (962EN)
40115	0072	CH5 Cal Lo Range 6	Raw A/D Count Value (See Note 2). ±156mV (962EN)
40116	0073	CH5 Cal Hi Range 7	Raw A/D Count Value (See Note 2). ±78mV (962EN)
40117	0074	CH5 Cal Lo Range 7	Raw A/D Count Value (See Note 2). ±78mV (962EN)
40118	0075	Ideal Range 0 Hi	Ideal A/D Count Value (See Note 2). 0-20mA (961EN) or ±10V (962EN)
40119	0076	Ideal Range 0 Lo	Ideal A/D Count Value (See Note 2). 0-20mA (961EN) or ±10V (962EN)
40120	0077	Ideal Range 1 Hi	Ideal A/D Count Value (See Note 2). 4-20mA (961EN) or ±5V (962EN)

## Register Map

**Model 961EN-6006**

**Model 962EN-6006**

*Shaded 4xxxx register entries are Read-Only.*



## Register Map

**Model 961EN-6006**  
**Model 962EN-6006**

*Shaded 4xxxx registers are Read-Only.*

Ref	Addr.	Description	Data Type/Format
<b>Holding Registers (4x References, Read/Write)</b>			
40121	0078	<i>Ideal Range 1 Lo</i>	<i>Ideal A/D Count Value (See Note 2). 4-20mA (961EN) or ±5V (962EN)</i>
40122	0079	<i>Ideal Range 2 Hi</i>	<i>Ideal A/D Count Value (See Note 2). 0-11.17mA (961EN) or ±2.5V (962EN)</i>
40123	007A	<i>Ideal Range 2 Lo</i>	<i>Ideal A/D Count Value (See Note 2). 0-11.17mA (961EN) or ±2.5V (962EN)</i>
40124	007B	<i>Ideal Range 3 Hi</i>	<i>Ideal A/D Count Value (See Note 2). 0-1mA (961EN) or ±1.25V (962EN)</i>
40125	007C	<i>Ideal Range 3 Lo</i>	<i>Ideal A/D Count Value (See Note 2). 0-1mA (961EN) or ±1.25V (962EN)</i>
40126	007D	<i>Ideal Range 4 Hi</i>	<i>Ideal A/D Count Value (See Note 2). ±625mV (962EN)</i>
40127	007E	<i>Ideal Range 4 Lo</i>	<i>Ideal A/D Count Value (See Note 2). ±625mV (962EN)</i>
40128	007F	<i>Ideal Range 5 Hi</i>	<i>Ideal A/D Count Value (See Note 2). ±313mV (962EN)</i>
40129	0080	<i>Ideal Range 5 Lo</i>	<i>Ideal A/D Count Value (See Note 2). ±313mV (962EN)</i>
40130	0081	<i>Ideal Range 6 Hi</i>	<i>Ideal A/D Count Value (See Note 2). ±156mV (962EN)</i>
40131	0082	<i>Ideal Range 6 Lo</i>	<i>Ideal A/D Count Value (See Note 2). ±156mV (962EN)</i>
40132	0083	<i>Ideal Range 7 Hi</i>	<i>Ideal A/D Count Value (See Note 2). ±78mV (962EN)</i>
40133	0084	<i>Ideal Range 7 Lo</i>	<i>Ideal A/D Count Value (See Note 2). ±78mV (962EN)</i>
40134	0085	<i>Reserved</i>	<i>Do Not Use</i>
40135	0086	<i>Reserved</i>	<i>Do Not Use</i>
40136	0087	<i>Span Cal Register</i>	<i>A 16-Bit value whose bit position when set indicates the channel to be calibrated for span. For example: to calibrate span of channel 0, write 0001H to this register. To calibrate span of channel 5, write 0020H to this register. <b>IMPORTANT:</b> You must FIRST write 5E2AH into the Calibration Access Register (Register 40021) before attempting calibration.</i>
40137	0088	<i>Zero Cal Register</i>	<i>A 16-Bit value whose bit position when set indicates the channel to be calibrated for zero. For example: to calibrate zero of channel 0, write 0001H to this register. To calibrate zero of channel 5, write 0020H to this register. <b>IMPORTANT:</b> You must FIRST write 5E2AH into the Calibration Access Register (Register 40021) before attempting calibration.</i>
43001 . .		<i>This block Mirrors 3xxxx Registers.</i>	<i>Refer to Register Mirroring. 3xxxx Input Registers are mapped to the 43xxx Holding Register space using an address offset of 43000.</i>

**Notes (Memory Map):**

1. Input values are 16-bit signed integer values representing percent with a resolution of 0.005%/lsb.  $\pm 20000$  is used to represent  $\pm 100\%$ . The full range is  $-163.84\%$  (-32768 decimal) to  $+163.835\%$  (+32767 decimal). For example,  $-100\%$ ,  $0\%$  and  $+100\%$  are represented by decimal values  $-20000$ ,  $0$ , and  $+20000$ , respectively. Bipolar voltage ranges (962EN) use  $\pm 100\%$  (span of  $-20000$  to  $+20000$ ), current ranges (961EN) use  $0-100\%$  (span of  $0$  to  $20000$ ).
2. The 962EN A/D Count value is calculated via the expression:  $\text{count} = (32768 * V_{in} * \text{Gain} / V_{ref}) + 32768$ , where  $V_{ref} = 1.235V$ . Gain is 1 ( $\pm 10V$  range), 2 ( $\pm 5V$ ), 4 ( $\pm 2.5V$ ), 8 ( $\pm 1.25V$ ), 16 ( $\pm 625mV$ ), 32 ( $\pm 313mV$ ), 64 ( $\pm 156mV$ ), and 128 ( $\pm 78mV$ ).  
The 961EN A/D Count value is calculated via the expression:  $\text{count} = (32768 * I_{in} * 24.9\Omega * \text{Gain} / V_{ref}) + 32768$ , where  $V_{ref} = 1.235V$ . Gain is 2 (0-20mA & 4-20mA range), 4 (0-11.17mA range), or 32 (0-1mA range).

These DIN-rail mount, industrial Ethernet, analog input modules will condition up to six differential DC current (961EN), or voltage (962EN) input signals, and provide an isolated 10/100BaseT Ethernet port for monitoring and control. Units are DC-powered and include reverse polarity protection. Analog inputs (as a group), network, and power are isolated from each other. Non-volatile reprogrammable memory in the module stores configuration and calibration information.

The BusWorks model prefix "900" denotes the Series 900 network I/O family. The "EN" suffix denotes EtherNet. Select 961EN for current input, and 962EN for voltage input. The four digit suffix of this model number represents the following options, respectively: "6" = EtherNet/IP; "0" = Default; "06" = 6 Channels.

Up to six process current or voltage input channels, according to model number. The unit can be configured to accept one of several input ranges at each group of 3 channels as described below. The unit must be wired and configured for the intended input type and range (see Connections section for details). The following paragraphs summarize this model's input types, ranges, and applicable specifications.

**DC Current (961EN Only):** Configurable for 0 to 20mA, 4-20mA, 0-11.17mA, and 0-1mA DC nominal input ranges. A precision  $24.9\Omega$  current sink resistor converts the input current to a voltage that is processed by the A/D converter. An optional external sensor is required to monitor AC current signals (Acromag Model 5020-350). This sensor generates a DC milliamper signal of 0 to 11.17mA for the module (see Table 1 below for scaling to AC current).  
**Current Input Reference Test Conditions:** 4 to 20mA current input; ambient temperature =  $25^{\circ}C$ ; 24VDC supply.  
**Input Overvoltage Protection:** Bipolar Transient Voltage Suppressors (TVS), 5.2V clamp level typical.

**Register Map****Model 961EN-6006****Model 962EN-6006****SPECIFICATIONS****Model Numbers**

961EN-6006 (6 DC Current In)  
962EN-6006 (6 DC Voltage In)

**Analog Inputs**



## SPECIFICATIONS

### Analog Inputs

**AC Current Sensor (Model 5020-350, For Use With 961EN):** This sensor is a toroidal instrument transformer that converts a sinusoidal 50-60Hz AC current signal into a low level DC milliampere signal of 0 to 11.17mA. The input AC current range is a function of the number of turns placed through the toroid as shown in Table 1 below. This sensor is isolated and requires no calibration or adjustment. When used with a 961EN module, it provides redundant input isolation and may facilitate input-to-input isolation of this six channel unit.

**Table 1: AC Current Sensor Turns & Range**

AC Current Input Range	Primary Turns	Sensor Output (Red/Black Wires)
0 to 20A AC	1	0 to 11.17mA DC
0 to 10A AC	2	"
0 to 5A AC	4	"
0 to 2A AC	10	"
0 to 1A AC	20	"

The output wires of this sensor are polarized with red as (+) plus and black as (-) minus. Normally these output wires are attached to one end of a user supplied cable while the other end connects to the 961EN's process current input terminals.

**Input Burden:** A function of the wire gauge resistance used for primary turns (the current carrying wire being monitored).

**AC Current Sensor to Transmitter Wiring Distance:** 400 feet maximum for 18 gauge wire. Other wire gauges can be used as long as the resistance of both wires is less than 5Ω.

**Input Overload:** The AC current sensor will withstand overload conditions as follows:

- 20 times full scale for 0.01 seconds.
- 10 times full scale for 0.1 seconds.
- 5 times full scale for 1.0 second.

**DC Voltage (962EN Only):** A 10:1 input divider is installed at the input (utilizing divider resistor values of 100K and 10.5K). User-configurable for the nominal bipolar DC voltage ranges of ±10V, ±5V, ±2.5V, ±1.25V, ±625mV, ±313mV, ±156mV, and ±78mV DC.

**Input Impedance:** 110.5KΩ.

**Voltage Input Reference Test Conditions:** -10 to 10V DC input; ambient temperature = 25°C; 24VDC supply.

**Input Overvoltage Protection:** Bipolar Transient Voltage Suppressors (TVS), 18V clamp level typical.

### General Specifications

**Accuracy:** Better than ±0.05% of span, typical for nominal input ranges (except 0-1mA). This includes the effects of repeatability, terminal point conformity, and linearization, but does not include sensor error.

**Measurement Temperature Drift:** Better than ±50ppm/°C (±0.005%/°C).

**Analog to Digital Converter (A/D):** A 16-bit Σ-Δ converter.

**Resolution:** 0.005% or 1 part in 20000 (961EN), 0.0025% or 1 part in 40000 (962EN, full bipolar range).

**Input Conversion Rate:** 80ms per channel, or 480ms for six input channels.

**Input Filter:** Normal mode filtering, plus digital filtering optimized and fixed per input range within the  $\Sigma$ - $\Delta$  ADC.

**Input Filter Bandwidth:** -3dB at 3Hz, typical.

**Noise Rejection (Normal Mode):** 40dB @ 60Hz, typical with 100 $\Omega$  input unbalance.

**Noise Rejection (Common Mode):** 140dB @ 60Hz, typical with 100 $\Omega$  input unbalance.

**Data Types: Percentage** - A 16-bit signed integer value with resolution of 0.005%/lsb.  $\pm 20000$  is used to represent  $\pm 100\%$ . For example, -100%, 0%, and +100% are represented by decimal values -20000, 0, and 20000, respectively. The full range is -163.84% (-32768 decimal) to +163.835% (+32767 decimal).

**General Specifications**

**Note:** Channels 0, 1, & 2, and channels 3, 4, & 5 (every group of 3 channels) must share the same input configuration, but this configuration may vary between the two groups.

**Dimensions:** 1.05 inches wide, 4.68 inches tall, 4.35 inches deep. Refer to the dimensions drawing at the front of this manual.

**DIN Rail Mount:** Type EN50022; "T" rail (35mm).

**I/O Connectors:** Removable plug-in type terminal blocks rated for 15A/300V; AWG #12-24 stranded or solid copper wire.

**Network Connector:** 8-pin RJ-45 connector socket with metal shield (shield is bypassed to earth ground at the GND terminal via an isolation capacitor and TVS). Connections are wired MDI, as opposed to MDI-X. You must use a CAT-5 crossover cable to connect this module to a PC. Otherwise you may use an auto-crossing Ethernet switch, such as the Acromag 900EN-S005 to make connections.

**Enclosure & Physical**

RJ-45	Signal (MDI)	Description
1	Tx+	Transmit Positive
2	Tx-	Transmit Negative
3	Rx+	Receive Positive
4	Not Used	Connects to Pin 5
5	Not Used	Connects to Pin 4
6	Rx-	Receive Negative
7	Not Used	Connects to Pin 8
8	Not Used	Connects to Pin 7

**Case Material:** Self-extinguishing NYLON type 6.6 polyamide thermoplastic UL94 V-2, color beige; general purpose NEMA Type 1 enclosure.

**Printed Circuit Boards:** Military grade FR-4 epoxy glass.

**Shipping Weight:** 1 pound (0.45 Kg) packed.

**Safety Approvals:** CE marked (EMC Directive 89/336/EEC), UL Listed (UL3121-First Edition, UL1604), cUL Listed (Canada Standard C22.2, No. 1010.1-92), Hazardous Locations: Class 1; Division 2; Groups A, B, C, D.

**Conformance:** EtherNet/IP CONFORMANCE TESTED™.

**Agency Approvals**

## Environmental

**Operating Temperature:** -25°C to +70°C (-13°F to +158°F).  
**Storage Temperature:** -40°C to +85°C (-40°F to +185°F).  
**Relative Humidity:** 5 to 95%, non-condensing.  
**Power Requirements:** 15-36V DC SELV (Safety Extra Low Voltage), 2W.  
 Observe proper polarity. See table for current.

**CAUTION:** Do not exceed 36VDC peak, to avoid damage to the module.

**External Fuse:** Select a high surge tolerant fuse rated for 1A or less to protect unit.

Supply	961/962EN-6006 Current Draw
15V	103mA Typical, 113mA Maximum
18V	86mA Typical, 95mA Maximum
24V	67mA Typical, 74mA Maximum
36V	50mA Typical, 55mA Maximum

**CAUTION:** Risk of Electric Shock – More than one disconnect switch may be required to de-energize equipment before servicing.

**Isolation:** Input channels (as a group), power, and network circuits are isolated from each other for common-mode voltages up to 250VAC, or 354V DC off DC power ground, on a continuous basis (will withstand 1500VAC dielectric strength test for one minute without breakdown). Complies with test requirements of ANSI/ISA-82.01-1988 for voltage rating specified.

**Installation Category:** Designed to operate in an installation in a Pollution Degree 2 environment with an installation category (over-voltage category) II rating.

**Electromagnetic Interference Immunity (EMI):** Unit has demonstrated measurement shift less than  $\pm 0.25\%$  of input span with interference from switching solenoids, commutator motors, and drill motors.

**Emissions Per European Norm EN50081-1:**

**Radiated Frequency Emissions:** 30 to 1000MHz per EN55022 Class A

**WARNING:** This is a Class A product. In a domestic environment, this product may cause radio interference in which the user may be required to take adequate measures.

**Electromagnetic Compatibility (EMC) -**

**Minimum Immunity Per European Norm EN50082-1:**

**Electrostatic Discharge (ESD) Immunity:** 4KV direct contact and 8KV air-discharge to the enclosure port per EN61000-4-2.

**Radiated Field Immunity (RFI):** 10V/M, 80 to 1000MHz AM and 900MHz keyed carrier, per EN61000-4-3 and ENV50204.

**Electrical Fast Transient Immunity (EFT):** 2KV to power, and 1KV to signal I/O per EN61000-4-4.

**Conducted RF Immunity (CRFI):** 10V rms, 150KHz to 80MHz, per EN61000-4-6.

**Surge Immunity:** 0.5KV per EN61000-4-5.

*These limits represent the minimum requirements of the standard, but product has typically been tested to comply with higher standards in some cases.*

**IMPORTANT:** Power, input, and output (I/O) wiring must be in accordance with Class I, Division 2 wiring methods of Article 501-4(b) of the National Electrical Code, NFPA 70 for installations in the US, or as specified in section 18-1J2 of the Canadian Electrical Code for installations within Canada and in accordance with the authority having jurisdiction.

**This equipment is suitable for use in Class I, Division 2, Groups A, B, C, and D, or non-hazardous locations only.**

**WARNING – EXPLOSION HAZARD –** Substitution of components may impair suitability for Class I, Division 2.

**WARNING – EXPLOSION HAZARD –** Do not disconnect equipment unless power has been switched off or the area is known to be non-hazardous.

**Connector:** Shielded RJ-45 socket, 8-pin, 10BaseT/100BaseTX.

**Wiring:** Wired MDI. Unit does NOT support auto-crossover.

**Protocol:** EtherNet/IP w/Web Browser Configuration. Unit also provides 1 socket connection for Modbus TCP/IP.

**IP Address:** Default static IP address is 128.1.1.100.

**Port:** Up to 10 sockets supported for EtherNet/IP, plus one socket for Modbus TCP/IP (uses port number 502 which is reserved for Modbus).

**Transient Protection:** Transient Voltage Suppressors (TVS) are applied differentially at the transmit and receive channels. Additionally, the metal shield is coupled to the earth ground terminal via an isolation capacitor and TVS.

**Data Rate:** Auto-sensed, 10Mbps or 100Mbps.

**Duplex:** Auto-negotiated, Full or Half Duplex.

**Compliance:** IEEE 802.3, 802.3u, 802.3x.

**EtherNet/IP Protocol Support:** Uses built-in web pages for configuration and control over ethernet via a standard web browser. Up to 10 application sockets via EtherNet/IP, and 1 socket via Modbus TCP/IP (the module uses the standard Modbus TCP/IP socket 502).

**Rx/Tx Memory:** 8K bytes internal SRAM memory for receive and transmit buffers (FIFO).

**Communication Distance:** The distance between two devices on an Ethernet network is generally limited to 100 meters using recommended copper cable. Distances may be extended using hubs, switches, or fiber optic transmission. However, the total round trip delay time must not exceed 512 bit times for collision detection to work properly with CSMA/CD (half-duplex).

**Port Status Indicators:** Green LED indicates link status (ON if auto-negotiation has successfully established a connection), yellow LED indicates activity (ethernet connection is busy/traffic is present).

**Address:** The module IP address can be preset by the user (static) and loaded from internal non-volatile memory, or it can be automatically acquired at startup via a network server using a BOOTP (Bootstrap Protocol), or DHCP (Dynamic Host Configuration Protocol). The unit also includes a default mode toggle switch to cause the module to assume a "known" fixed static IP address of 128.1.1.100 for troubleshooting purposes. The module may also use DHCP with a fallback to the static IP address, or the last DHCP assigned address.

## Environmental

## Ethernet Interface

*Refer to Acromag Application Note 8500-734 for instructions on how to change the IP address of your PC network interface card in order to talk to an Acromag module.*

## Controls & Indicators

### LED Indicators:

**RUN (Green)** - Constant ON if power is on. Continuous flashing ON/OFF indicates unit is in "wink" ID mode.

**ST (Yellow)** – Blinks ON/OFF in default communication mode. Stays ON if an input is out of range.

**LINK (Green)** – Indicates Ethernet *link* status (ON if auto-negotiation has successfully established a connection).

**ACT (Yellow)** – Indicates Ethernet *activity* (Ethernet connection is busy/traffic is present).

### Controls:

**Reset/Default Address Switch:** This momentary toggle switch is located on the front panel and is used to either reset the module (toggle right), or cause the module to assume a default IP address (toggle left). Module address is initially set to 128.1.1.100 at the factory, or may be preset by the user. This switch can also be used to restore the module to its initial factory configuration by holding this switch in its default position while powering up the unit (see "Getting Out Of Trouble" in the Troubleshooting section for more information).

## ACCESSORY CABLES

The minimum cable required for full operation of this device is Category 5. The term "Category" refers to classifications of UTP (Unshielded Twisted Pair) and STP (Shielded Twisted Pair) cables. There are 3 main categories of cable – Category 3, Category 4, and Category 5. The differences in classification is found in their electrical performance and this is documented in the TIA/EIA 568-A standard.

This device is designed for use in harsh industrial environments. Acromag recommends the use of shielded cable when wiring to this device. Select STP (Shielded Twisted Pair) cable rather than UTP (Unshielded Twisted Pair). The use of shielded cable will help protect the data being transmitted from harmful EMI (Electromagnetic Interference) and RFI (Radio Frequency Interference). It will also help to lower your radiated emissions by keeping the cable from emitting EMI and RFI.

There are two types of cable conductors: solid cable and stranded cable. Stranded cables are more flexible than solid cables. But since attenuation is higher for stranded cables than solid conductor cables, these are generally reserved for short runs and patch applications less than 6 meters.

Currently there are two types of shielding employed in Category 5 STP cable: single-shielded and double-shielded. Both of these cables have the same core and jacket as UTP cables, but also include a thin foil outer shield that covers all four twisted-wire pairs. Variations may include a drain wire that encircles the outer jacket. A double-shielded version adds an outer wire screen that surrounds the foil shield and also functions as a drain wire. The drain wire or wire screen typically makes contact at each end of the cable with the metal shield around special RJ45 plug connectors. This shield then makes contact with the metal shield of shielded RJ45 sockets. The socket shield may make direct contact with earth ground, or it may be capacitively coupled to earth ground. In the Acromag 9xxEN modules, it makes contact with earth ground via a high voltage capacitor and transient voltage suppressor. In addition to separately isolating the shield, this helps to minimize radio frequency and electromagnetic interference, and has the added benefit of protection from ESD (Electro-Static Discharge).

Further, Acromag recommends the use of *enhanced* Category 5 cable (CAT-5e). This cable has all the characteristics of Category 5, but includes enhancements that help to minimize crosstalk. Category 5e cable has a greater number of turns-per-inch in its twisted pairs and its performance is also more suitable for applications that make use of all four wire pairs for simultaneous bidirectional data transmission (full-duplex). As such, it is rated for frequencies up to 200MHz, double the rate of Category 5. This cable is defined in TIA/EIA-568A-5 (Addendum 5).

Acromag offers the following cable accessories for use with this module:

**Cable Model 5035-355** – A yellow, 3 foot long, single-shielded Category 5e STP patch cable with drain wire and an RJ45 plug at both ends. Use this cable to connect an Acromag 9xxEN I/O module to the Acromag 900EN-S005 switch.

**Cable Model 5035-360** – A green, 5 foot long, single-shielded Category 5e STP crossover cable with a drain wire and an RJ45 plug at both ends. This cable performs the Ethernet crossover function and is used to connect a PC directly to an Acromag Series 9xxEN I/O module.

Note that you do not need to use a crossover cable to connect your PC to this module if the Acromag 900EN-S005 switch is used between the PC and module, as the switch is auto-crossing. However, you must use a crossover cable when directly connecting your PC to a Series 9xxEN I/O Module without the use of an auto-crossing switch or hub.

You may obtain cable in other lengths and colors as required for your application from other vendors. For example, shielded CAT-5e cable is available from the following vendors:

- L-com Connectivity Products, [www.L-com.com](http://www.L-com.com)
- Pro-Link, [www.prolink-cables.com](http://www.prolink-cables.com)

For very noisy environments or in the presence of strong electrical fields, you can obtain double-shielded CAT-5e cable and shielded RJ45 plugs from the following vendors:

- L-com Connectivity Products, [www.L-com.com](http://www.L-com.com), see cable model TFSC2004 and shielded plug T8P8CSR.
- Regal Electronics, [www.regalusa.com](http://www.regalusa.com), see shielded plug model 1003B-8P8CSR-C5.

Complete premium double-shielded Category 5e standard and crossover cables in variable lengths can be obtained from Lumberg at [www.lumbergusa.com](http://www.lumbergusa.com) (refer to their etherMate line). For example, specify RJ45S-RJ45S-656/B/3M for a double-shielded, 3 meter straight cable. Specify RJ45S-RJ45S-656/BX/3M for a double-shielded, 3 meter crossover cable.

## ACCESSORY CABLES

### Patch Cable & Crossover Cable