

Wi125 Evaluation Kit User Manual

Issue: R00

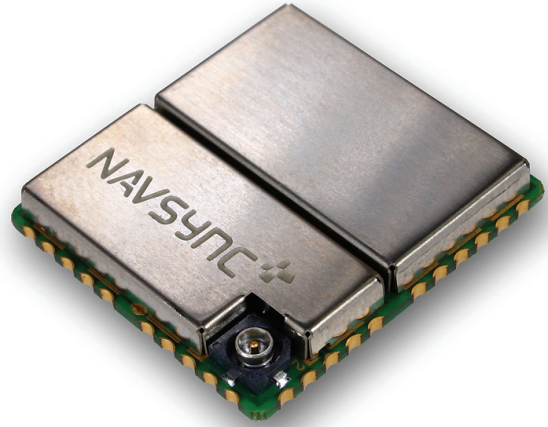

Bulletin	SG172-DKUM
Revision	R00
Date	02 Feb 2010

Table of Contents

1.	Introduction	3
2.	Wi125 Evaluation Board Overview	3
3.	General Specifications	4
	3.1 Operating Specifications	4
4.	Interfaces	5
	4.1 Power	5
	4.2 Wi125 (U3)	5
	4.3 UART Connections (J1, J2, J3)	5
	4.4 Antenna Connection (J8)	5
	4.5 Power On and Reset Switches	5
	4.6 LED Indicators	5
	4.7 Timing Outputs	6
5.	Operating Instructions	6
6.	Connector Pin outs	7
	6.1 Jumper Description & Settings	7
	6.2 RS232 DB9 Connectors	7
	6.3 DC Power Connector	7
	6.4 SMA Timing and Event-In Connectors	7
	6.5 TNC Antenna Connector	7
	6.6 External Clock Connector	8
	6.7 Auxiliary Connector	8
	6.8 JTAG Connector	8
	Appendix 1 Evaluation Board Schematic	9

1. Introduction

The Wi125 Evaluation Kit is a complete development platform for the Wi125 GPS receiver (Wi125). It is comprised of the Wi125 Evaluation Board and peripherals that support its operation. The Wi125 is a small size OEM module specifically designed for use in weak signal GPS environments and where there is a requirement for highly accurate timing. Refer to Wi125 User Manual for details. The Full Wi125 Evaluation Kit includes:

- Wi125 Evaluation Board
- Interface DB9 Serial RS232 Cable
- Power Supply Adaptor (Region Specific) with 2.1 mm plug.
- Magnetic Patch Antenna with a 3m lead
- CD, which provides Navsync Manuals, datasheets and GPS Parser Software, NS3K View.

The Wi125 Evaluation Board can be purchased individually with a pick-and-choose option for accessories. This may reduce cost if the customer already possesses such accessories.

2. Wi125 Evaluation Board Overview

The main purpose of the Wi125 Evaluation Board is to provide a power supply, battery backup, RS232 interface and easy access to the Wi125 functionality. A TNC connector is available for an active antenna and SMA connectors are on board for easy connection to the timing, 1PPS and frequency outputs. Access to the Event-In pin is also available through an SMA connection. The antenna power is provided by on-board circuitry. A connection point (BT1) is available as an alternate to the 2.1 Barrel Socket for a DC power supply. If field tests need to be carried out, a 4AA battery pack can also be attached to the BT1 connection port.

The Wi125-Evaluation Board is a stand-alone GPS board, providing simple interfaces to host systems such as a PC.

The Evaluation Board provides:

- On-board Wi125-NAV (Navigation) or Wi125-TIM (Timing)
- 3.3VDC Power Regulation, which allowing input voltage of 4.5VDC to 25VDC
- RS232 Interface to each of the 3 UARTs of the Wi125: NMEA, Debug, Net Assist
- RF-IN Female TNC connector
- SMA CO-AX connector for the 1PPS and Frequency outputs (Wi125-TIM only)
- Battery Backup Circuit for the Wi125's RTC when power is not applied.
- LED Indicators for GPS status, Power status and a 1PPS blinking LED
- Current measuring headers at the Wi125 power supply inputs
- Reset and Power switches

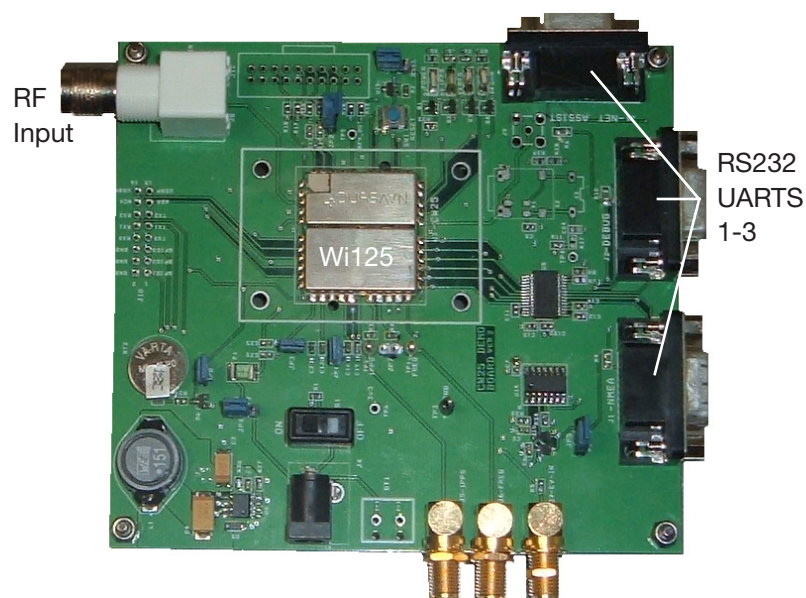

Figure 1 Wi125 Evaluation Board

3. General Specifications

If not otherwise specified, all performance data refers to the Wi125.

3.1 Operating Specifications

Parameter	Min	Typical	Max	Units
Operating Temperature	-30		+65	°C
Power Supply Voltage (VDC)	4.5	5	25	VCC
Power Consumption		0.62		W
UART Interfaces (x3) J1, J2, J3	D-SUB 9-WAY, RS232			
Active Antenna Connector	TNC Socket Female			
Power Connector (DC)	2.1mm Barrel, Center Positive [Cliff DC-10]			
Dimensions	125 x 120 x 30mm (approx, Board Only)			
Weight	128g (approx, Board Only)			

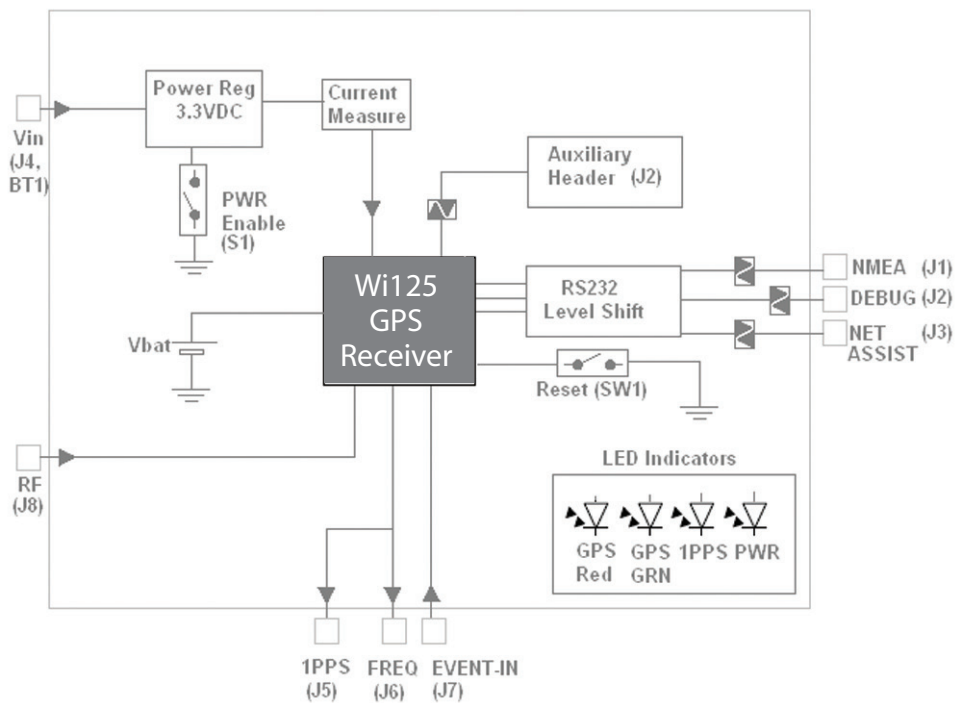

Figure 2 Wi125 Block Diagram

4. Interfaces

4.1 Power

The Wi125 Evaluation Board can be operated from two sources of DC power: a standard DC Power adaptor with a 2.1mm DC Plug connected to J4, or the alternative connection point BT1, a battery pack or DC cables which can be soldered directly to the \pm terminals.

4.2 Wi125 (U3)

The Wi125 is mounted on the board, depending on the Demo version ordered. Please see the Wi125 datasheets along with the Wi125 User Manual for detailed information.

4.3 UART Connections (J1, J2, J3)

The Wi125 Demo provides RS232 level shifting (TX, RX, GND) to interface the Wi125 GPS receiver with a PC via either a standard serial port or a USB-serial adapter (example Roline USB Type A -serial DB9ST). For detailed information of data streams and command format refer to User Manual.

UART 1(J1) - Main UART of the Wi125, for NMEA message and Command Configurations

UART 2 (J2) - Debug Messages

UART 3 (J3) - Net Assist

4.4 Antenna Connection (J8)

The antenna is connected using the female socket TNC connector, J8, on the Wi125-Demo Unit. A patch antenna is supplied with the kit. If the necessary antenna has a different connector, a suitable adaptor is required. The Evaluation Board provides 3.3VDC at the antenna jack to power active antennas. Higher voltage antenna can be accommodated (up to +15VDC) by routing the input power V_{in} to power the antenna. Jumper header JP4 determines the source power for the antenna. The jumper is placed in the 'P2' position for direct DC-IN or P1 for the standard 3.3VDC on-board supply. If the 'P2' position is used the board supply input voltage must remain below 15VDC. Care must be taken to insure that no more than 50mA is drawn from the Antenna connection otherwise damage may be caused to the Wi125 unit.

4.5 Power On and Reset Switches

The Power-On Slide Switch, S1, enables the 3.3VDC Regulator. When power is connected to the board and S1 is in the 'ON' position, the yellow LED, D1 will be fully ignited.

The Reset Push switch, SW1, is connected to the NPOR signal of the Wi125 unit. This can be pushed to reset the Wi125.

4.6 LED Indicators

Power-ON LED, D1

This yellow LED is fully on when 3.3VDC is applied to the Board.

1PPS LED, D2

This 1PPS LED toggles ON/OFF when the 1PPS signal is present.

GPS Status Red, D3

On the standard Wi125-TIM and NAV software builds, the GPS Red works as follows:

- Long red flash for invalid GPS fix
- Short red flashes for satellites tracked, but not used in solution.

GPS Status Green, D4

On the standard Wi125-TIM and NAV software builds, the GPS Green works as follows;

- Long green flash for a valid 2D/3D fix
- Short green flashes for number of satellites used in solution

4. Indicators continued

4.7 Timing Outputs

1PPS Output

SMA, J5 - female standard socket. The 1PPS signal from the Wi125 is available here. It is directly connected to Pin 38 through a 33 ohm resistor.

A buffered 1PPS is also available on Pin 1 of each of the DB9 connectors. This signal can be inverted by selecting the 'P2' position of jumper header, JP5. Otherwise the Jumper is placed on 'P1' for the standard non-inverting buffered 1PPS.

Please note that these buffered 1PPS signals are CMOS levels, not RS232 levels.

Frequency Output

SMA, J6 - female standard socket. The default frequency from the Wi125 is 10Mhz. The SMA conductor is directly connected to Pin 39 through a 33 ohm resistor. (Output is only available on the Wi125-TIM version)

Event -In Input

SMA, J7 - female standard socket. Connected to the Event-In (Pin 39) of the Wi125. This is connected through a 33 ohm resistor.

5. Operating Instructions

1. Connect the Antenna to the TNC socket, J8
2. Place the Patch antenna in a sky view location
3. Connect a RS232 data cable (also an available accessory) to the NMEA Port, J3
4. Connect the remaining end of the cable to the RS232 COM port on a PC
5. Open Terminal Window or NavSync NS3K View GPS parser on the PC, with communications setting set to match the COM port used and the baud rate set to 38400 (default)
6. Connect the Power supply to the Board
7. Place the Slide Switch, S1, to position 1 to switch Power ON
8. The unit should start to stream data
9. Once the unit achieves a GPS lock, timing outputs will be valid and present

6. Connector Pin outs

6.1 Jumper Description & Settings

JUMPER	DESCRIPTION	Normal Position
JP1	DIG Power to Wi125, 3.3VDC	ON
JP2	RF Power to Wi125, 3.3VDC	ON
JP3	DIG Power to Wi125, 1.8VDC	ON
JP4	Antenna Supply, P1: 3.3VDC P2: Powered directly from J4/BT1	P1
JP5	Buffered 1PPS to J1/J2/J3(Pin1) Selection P1: 1PPS+(NON-INV) P2: 1PPS-(INV)	P1
JP6	Bootsel, Only to be placed when programming	OFF
JP7	Freq out to Event-in	ON
JP8	VBAT POWER TO Wi125	ON

6.2 RS232 DB9 Connectors

J1 - NMEA and Command		J2- Debug		J3 - Net Assist	
Pins	Description	Pins	Description	Pins	Description
1	1PPS+/1PPS- Buffered	1	1PPS+/1PPS- Buffered	1	1PPS+/1PPS- Buffered
2	TX0 RS232 Levels	2	TX1 RS232 Levels	2	TX2 RS232 Levels
3	RX0 RS232 Levels	3	RX1 RS232 Levels	3	RX2 RS232 Levels
5	GND	5	GND	5	GND

6.3 DC Power Connector

The DC power connector is a 2.1mm Barrel center positive socket connector [Cliff Component: DC-10A]

J4- DC -IN	
Pins	Description
CENTER	DC Power in + (4.5-25v)
OUTER	DC Power in - (GND)

6.4 SMA Timing and Event-In Connectors

J5 1PPS

Connected directly to Pin 38 of the Wi125 via a 33ohm resistor

J6 Frequency Out

Connected directly to Pin 39 of the Wi125 via a 33ohm resistor

J7 Event In

Connected directly to Pin 37 of the Wi125 via a 33ohm resistor

6.5 TNC Antenna Connector

This TNC is a standard TNC socket.

J8 RF-IN

A GPS TNC active antenna can be connected here. Power is supplied to the antenna from the Evaluation Board, see JP4 description.

6. Connector Pin outs continued

6.6 External Clock Connector

J9- Not fitted on Evaluation Board, only used for special hardware builds of the Wi125

6.7 Auxiliary Connector

The pins on this non-fitted connector are directly connected to the Wi125

J10 Auxiliary Connections

Pins	Description	Pins	Description
1	GPIO1(PIN 40)	9	TX1(PIN 5)
2	GND	10	RX1(PIN 6)
3	GPIO2(PIN 41)	11	TX2(PIN 3)
4	GND	12	RX2(PIN 4)
5	GPIO3(PIN 42)	13	N2WDA(PIN 29)
6	GND	14	N2WCK(PIN 28)
7	TX0(PIN 1)	15	USBP(PIN 30)
8	RX0(PIN 2)	16	USBN(PIN 31)

6.8 JTAG Connector

The pins on this non-fitted connector are directly connected to the Wi125

J11 JTAG Connections

Pins	Description	Pins	Description
1	VCC 3.3VDC	11	JSEL (PIN 21)
2	VCC 3.3VDC	12	GND
3	NTRST (PIN 15)	13	TDO (PIN 13)
4	GND	14	GND
5	TDI (PIN 14)	15	NRESET (PIN 10)
6	GND	16	GND
7	TMS (PIN 22)	17	NC
8	GND	18	GND
9	TCK (TDI)	19	NC
10	GND	20	GND

Appendix 1 Evaluation Board Schematic

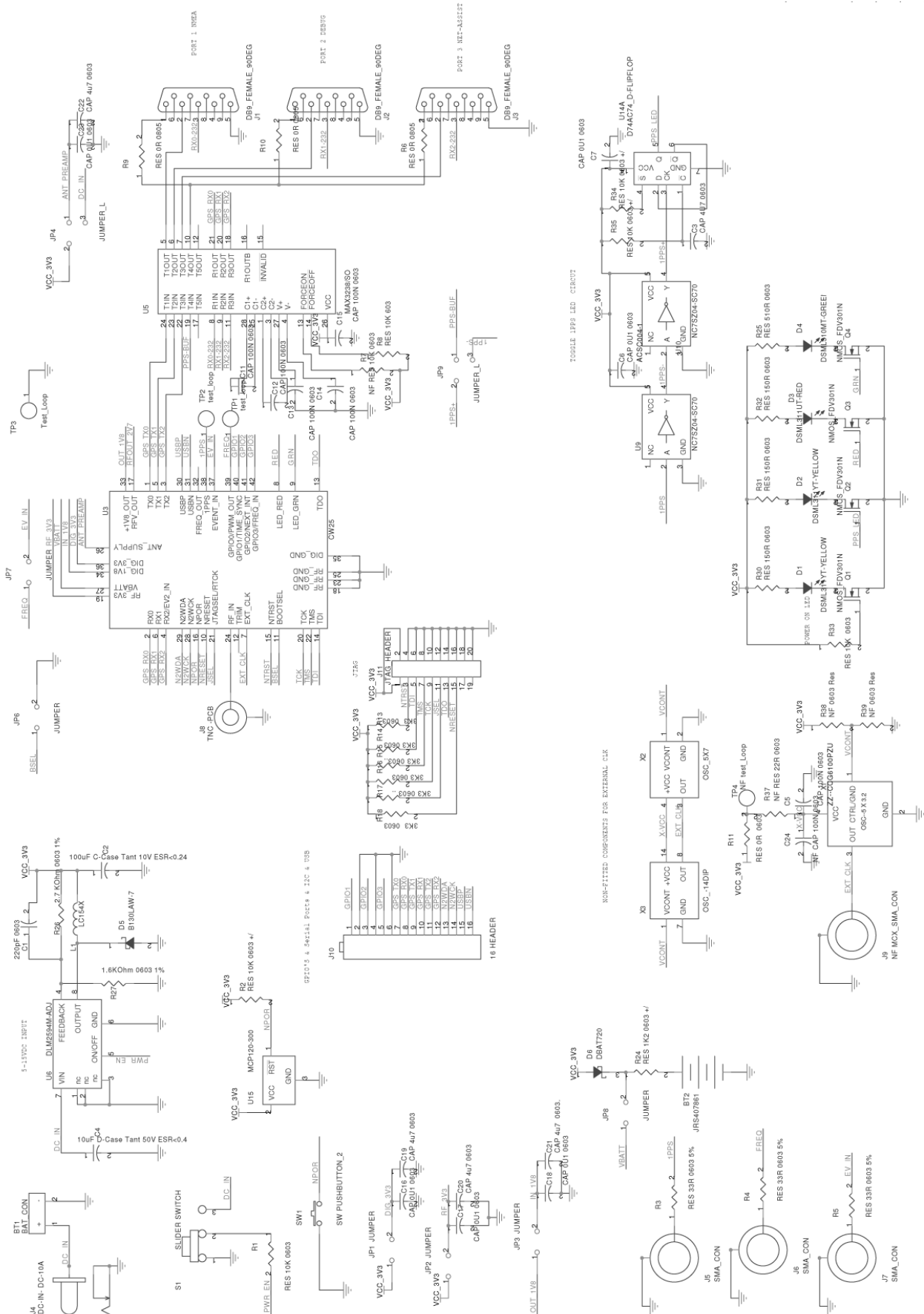

Wi125 Evaluation Kit User Manual

Issue: R00

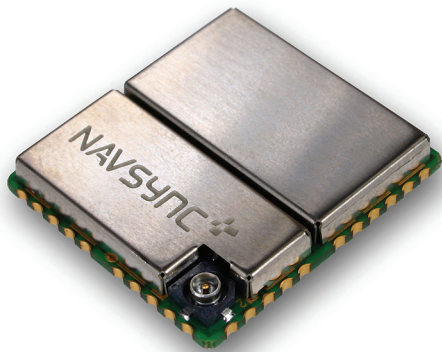

Revision	Revision Date	Notes
P00	02/03/09	Release
R00	02/16/09	Public Release
R01	02/02/10	Updates to Schematics & Drawings

NavSync, Ltd. Europe

Bay 143
Shannon Industrial Estate
Shannon, Co. Clare, Ireland
Phone: +353 61 475 666
E-mail: sales@navsync.com

North America

2111 Comprehensive Drive
Aurora, IL 60505, USA
Phone: 630.236.3026
E-mail: northamerica@navsync.com
www.navsync.com