

Short Form User's Manual

ACS320



Table of contents



Safety



Mechanical installation



Electrical installation



Start-up and control with I/O



The ABB logo, consisting of the letters 'ABB' in a bold, red, sans-serif font.

List of related manuals

DRIVE MANUALS	Code (EN)	
ACS320 Short Form User's Manual	3AUA0000086933	2)
ACS320 User's Manual	3AUA0000062599	
OPTION MANUALS	Code (EN)	
MFDT-01 FlashDrop User's Manual	3AFE68591074	2)
MREL-01 Relay Output Extension Module User's Manual for ACS310/ ACS320/ACS350	3AUA0000035974	2)
MUL1-R1 Installation Instructions for ACS150, ACS310, ACS320 and ACS350	3AFE68642868	1, 2)
MUL1-R3 Installation Instructions for ACS150, ACS310, ACS320 and ACS350	3AFE68643147	1, 2)
MUL1-R4 Installation Instructions for ACS310, ACS320 and ACS350	3AUA0000025916	1, 2)
SREA-01 Ethernet Adapter Module Quick Start-up Guide	3AUA0000042902	2)
SREA-01 Ethernet Adapter Module User's Manual	3AUA0000042896	3)
MAINTENANCE MANUALS	Code (EN)	
Guide for Capacitor Reforming in ACS50, ACS55, ACS150, ACS310, ACS320, ACS350, ACS550 and ACH550	3AFE68735190	

1) Multilingual

2) Delivered as a printed copy with the drive / optional equipment

3) Delivered in PDF format with the drive / optional equipment

All manuals are available in PDF format on the Internet. See section [Document library on the Internet](#) on page 43.

Purpose of the manual

This short form user's manual provides the basic information needed for installing and commissioning the drive.

For information on planning the electrical installation, operation with the control panel, program features, fieldbus, all accessible actual signals and parameters, fault tracing, maintenance, additional technical data and dimension drawings, refer to *ACS320 User's Manual* (3AUA0000062599 [English]). To access it on the Internet, go to www.abb.com/drives, select *Document Library*, enter the code in the search field and click OK.

Applicability

The manual is applicable to the ACS320 drive firmware version 4.03b or later. See parameter 3301 FIRMWARE in chapter *Actual signals and parameters* in *ACS320 User's Manual* (3AUA0000062599 [English]).

Table of contents

List of related manuals	2
Purpose of the manual	2
Applicability	2
1. Safety	
Safety in installation and maintenance	5
Safe start-up and operation	6
2. Hardware description	
Power connections and control interfaces	7
Type designation key	8
3. Mechanical installation	
Installing	9
4. Electrical installation	
Checking the compatibility with IT (ungrounded) and corner grounded TN systems	13
Connecting the power cables	14
Connecting the control cables	16
Installation checklist	18
5. Start-up and control with I/O	
How to start up the drive	19
How to control the drive through the I/O interface	26
6. Actual signals and parameters in the short view	
Terms and abbreviations	27
Fieldbus equivalent	27
Default values with different macros	28
Actual signals in the short parameter view	31
Parameters in the short parameter view	31
7. Technical data	
Ratings	37
Power cable sizes and fuses	39
UL checklist	40
Further information	
Product and service inquiries	43
Product training	43



4 Table of contents

Providing feedback on ABB Drives manuals	43
Document library on the Internet	43



1. Safety

Safety in installation and maintenance

These warnings are intended for all who work on the drive, motor cable or motor.

■ Electrical safety



WARNING! Ignoring the following instructions can cause physical injury or death, or damage to the equipment.

Only qualified electricians are allowed to install and maintain the drive!

- Never work on the drive, motor cable or motor when input power is applied. After disconnecting the input power, always wait for 5 minutes to let the intermediate circuit capacitors discharge before you start working on the drive, motor or motor cable.

Always ensure by measuring with a multimeter (impedance at least 1 Mohm) that there is no voltage between the drive input phases U1, V1 and W1 and the ground.

- Do not work on the control cables when power is applied to the drive or to the external control circuits. Externally supplied control circuits may carry dangerous voltage even when the input power of the drive is switched off.
- Do not make any insulation or voltage withstand tests on the drive.
- If a drive whose EMC filter is not disconnected is installed on an IT system (an ungrounded power system or a high resistance-grounded [over 30 ohms] power system), the system will be connected to ground potential through the EMC filter capacitors of the drive. This may cause danger or damage the drive.
- If a drive whose EMC filter is not disconnected is installed on a corner grounded TN system, the drive will be damaged.
- All ELV (extra low voltage) circuits connected to the drive must be used within a zone of equipotential bonding, ie within a zone where all simultaneously accessible conductive parts are electrically connected to prevent hazardous voltages appearing between them. This is accomplished by a proper factory grounding.

Note:

- Even when the motor is stopped, dangerous voltage is present at the power circuit terminals U1, V1, W1 and U2, V2, W2.
-
-



■ General safety



WARNING! Ignoring the following instructions can cause physical injury or death, or damage to the equipment.

- The drive is not field repairable. Never attempt to repair a malfunctioning drive; contact your local ABB representative or Authorized Service Center for replacement.
 - Make sure that dust from drilling does not enter the drive during the installation. Electrically conductive dust inside the drive may cause damage or lead to malfunction.
 - Ensure sufficient cooling.
-



Safe start-up and operation

These warnings are intended for all who plan the operation, start up or operate the drive.

■ General safety



WARNING! Ignoring the following instructions can cause physical injury or death, or damage to the equipment.

- Before adjusting the drive and putting it into service, make sure that the motor and all driven equipment are suitable for operation throughout the speed range provided by the drive. The drive can be adjusted to operate the motor at speeds above and below the speed provided by connecting the motor directly to the power line.
- Do not activate automatic fault reset functions if dangerous situations can occur. When activated, these functions will reset the drive and resume operation after a fault.
- Do not control the motor with an AC contactor or disconnecting device (disconnecting means); use instead the control panel start and stop keys  and  or external commands (I/O or fieldbus). The maximum allowed number of charging cycles of the DC capacitors (ie power-ups by applying power) is two per minute and the maximum total number of chargings is 15,000.

Note:

- If an external source for start command is selected and it is ON, the drive will start immediately after an input voltage break or fault reset unless the drive is configured for 3-wire (a pulse) start/stop.
-

2. Hardware description

Power connections and control interfaces

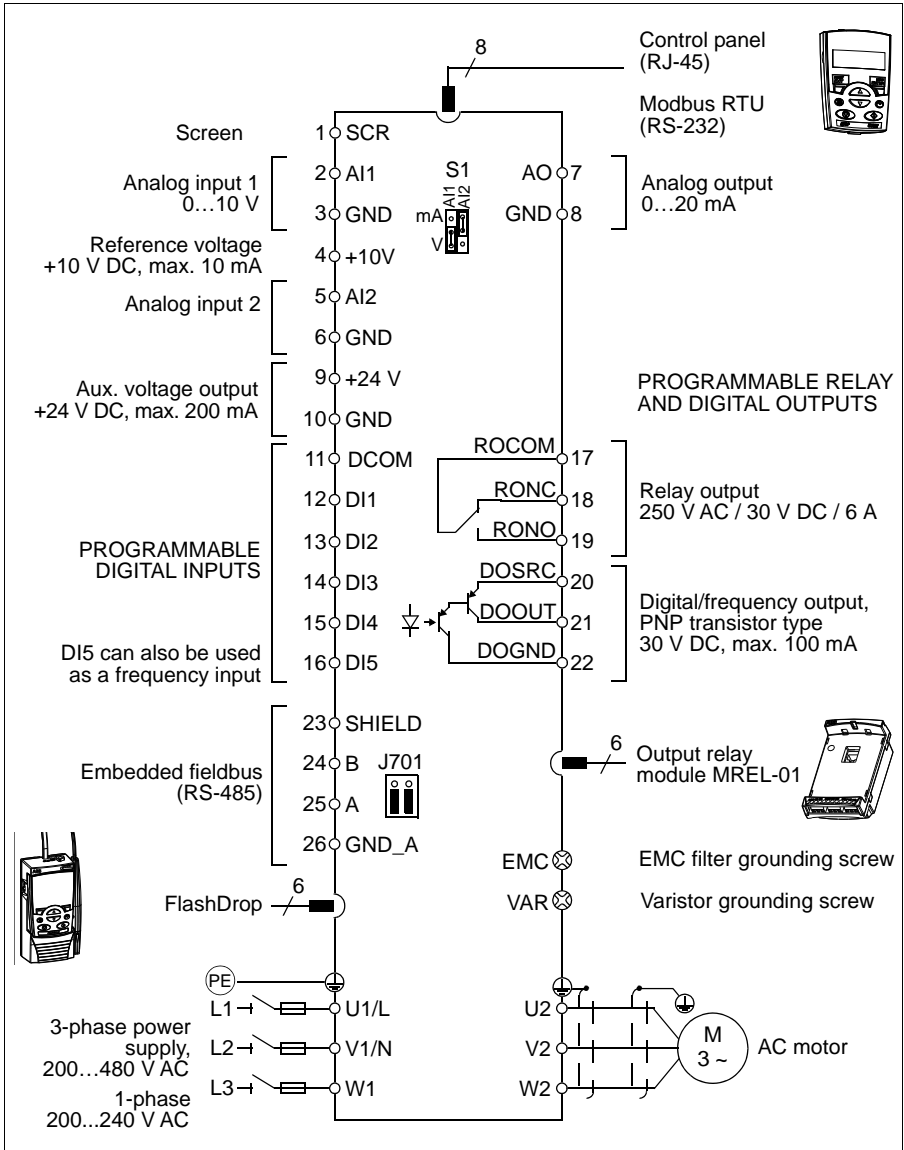

Type designation key

The type designation contains information on the specifications and configuration of the drive. You find the type designation on the type designation label attached to the drive. The first digits from the left express the basic configuration, for example ACS320-03E-09A7-4. The optional selections are given after that, separated by + signs, for example +J404. The explanations of the type designation selections are described below.

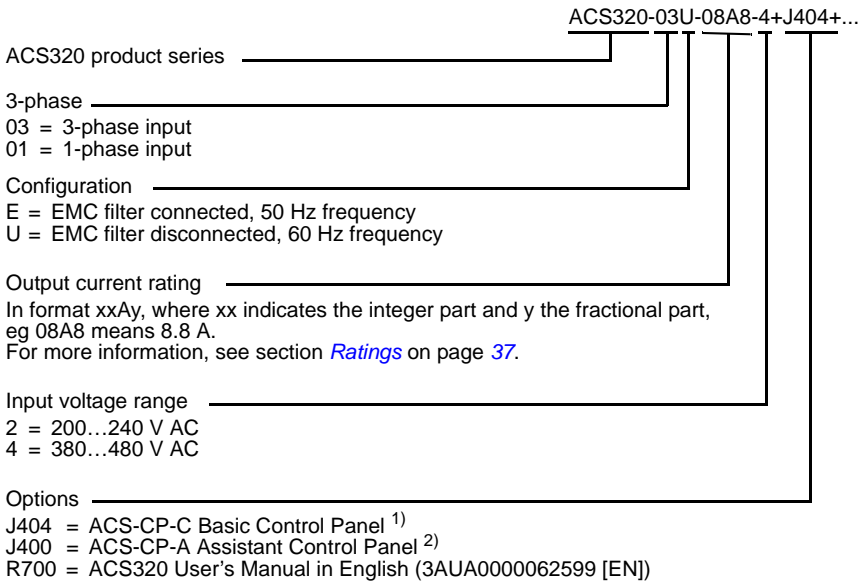

1) The ACS320 is compatible with ACS-CP-C Basic Control Panel Rev M or later.

2) The ACS320 is compatible with ACS-CP-B Assistant Control Panel Rev E or later (new panel series manufactured since 2007 with serial number XYYWWRXXXX, where year YY = 07 or greater and revision R = E, F, G, ...).

3. Mechanical installation

Installing

The instructions in this manual cover drives with the IP20 degree of protection. To comply with NEMA 1, use the MUL-R1, MUL-R3 or MUL-R4 option kit, which is delivered with multilingual installation instructions (3AFE68642868, 3AFE68643147 or 3AUA0000025916, respectively).

■ Install the drive

Install the drive with screws or on a DIN rail as appropriate.

The required free space for cooling above and below the drive is 75 mm (3 in). No free space is required on the sides, so drives can be mounted next to each other.

Note: Make sure that dust from drilling does not enter the drive during the installation.

With screws

1. Mark the hole locations using for example the mounting template cut out from the package. The locations of the holes are also shown in the drawings in chapter *Dimension drawings* in *ACS320 User's Manual* (3AUA0000062599 [English]). The number and location of the holes used depend on how the drive is installed:
 - a) back mounting (frame sizes R0...R4): four holes
 - b) side mounting (frame sizes R0...R2): three holes; one of the bottom holes is located in the clamping plate.
2. Fix the screws or bolts to the marked locations.

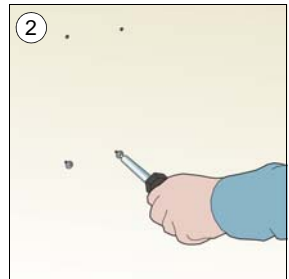
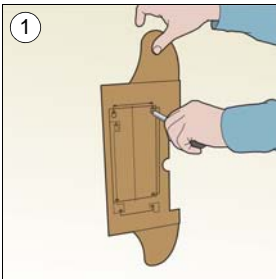

10 Mechanical installation

3. Position the drive onto the screws on the wall.
4. Tighten the screws in the wall securely.

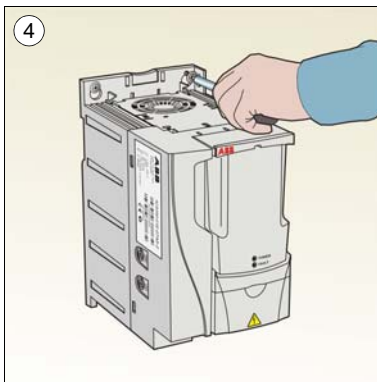
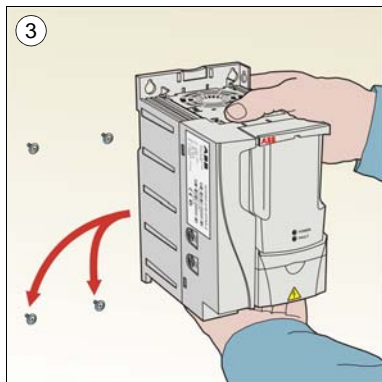

On DIN rail

1. Click the drive to the rail.
To detach the drive, press the release lever on top of the drive (1b).

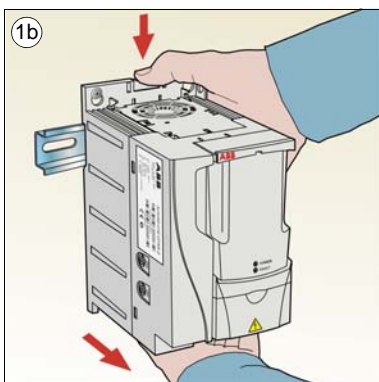
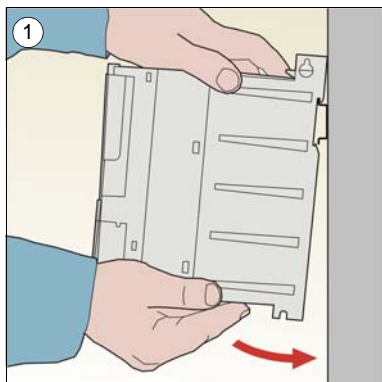

■ Fasten clamping plates

1. Fasten the clamping plate to the plate at the bottom of the drive with the provided screws.
2. Fasten the I/O clamping plate to the clamping plate (frame sizes R0...R2) with the provided screws.

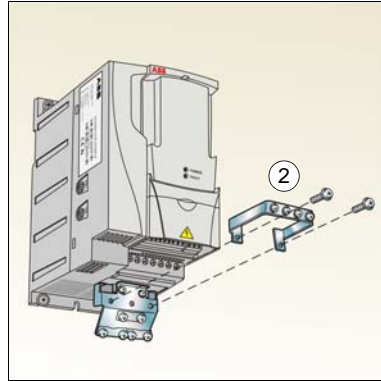
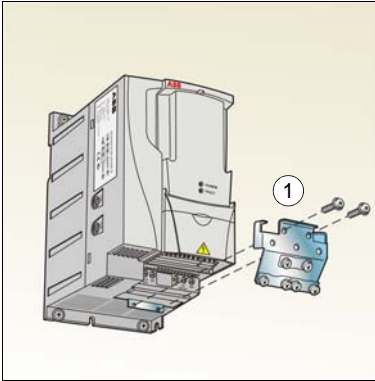



4. Electrical installation

⚠ WARNING! The work described in this chapter may only be carried out by a qualified electrician. Follow the instructions in chapter [Safety](#) on page 5. Ignoring the safety instructions can cause injury or death.

Make sure that the drive is disconnected from the input power during installation. If the drive is already connected to the input power, wait for 5 minutes after disconnecting the input power.

Checking the compatibility with IT (ungrounded) and corner grounded TN systems

⚠ WARNING! If a drive whose EMC filter is not disconnected is installed on an IT system (an ungrounded power system or a high resistance-grounded [over 30 ohms] power system), the system will be connected to ground potential through the EMC filter capacitors of the drive. This may cause danger or damage the drive.

If a drive whose EMC filter is not disconnected is installed on a corner grounded TN system, the drive will be damaged.

1. If you have an IT (ungrounded) or corner grounded TN system, disconnect the internal EMC filter by removing the EMC screw. For 3-phase U-type drives (with type designation ACS320-03U-), the EMC screw is already removed at the factory and replaced by a plastic one.

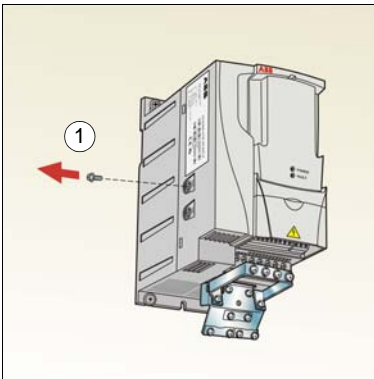

Note: In frame size R4 the EMC screw is located to the right of terminal W2.



Connecting the power cables

■ Connection diagram

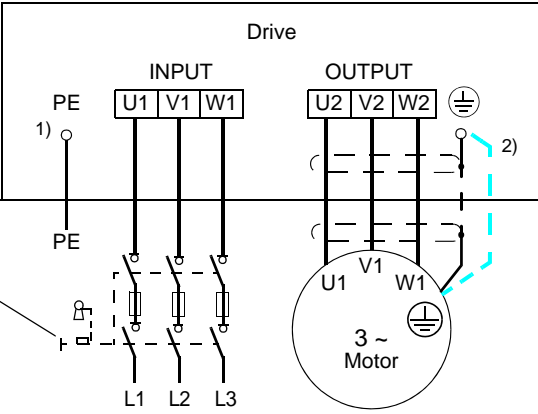

For alternatives, see chapter *Planning the electrical installation*, section *Selecting the supply disconnecting device (disconnecting means)* in *ACS320 User's Manual* (3AUA0000062599 [English]).

- 1) Ground the other end of the PE conductor at the distribution board.
- 2) Use a separate grounding cable if the conductivity of the cable shield is insufficient (smaller than the conductivity of the phase conductor) and there is no symmetrically constructed grounding conductor in the cable. See chapter *Planning the electrical installation*, section *Selecting the power cables* in *ACS320 User's Manual* (3AUA0000062599 [English]).

Note:

Do not use an asymmetrically constructed motor cable.

If there is a symmetrically constructed grounding conductor in the motor cable in addition to the conductive shield, connect the grounding conductor to the grounding terminal at the drive and motor ends.

Route the motor cable, input power cable and control cables separately. For more information, see chapter *Planning the electrical installation*, section *Routing the cables* in *ACS320 User's Manual* (3AUA0000062599 [English]).

Grounding of the motor cable shield at the motor end

For minimum radio frequency interference:

- ground the cable by twisting the shield as follows: flattened width $\geq 1/5 \cdot \text{length}$
- or ground the cable shield 360 degrees at the lead-out of the motor terminal box.

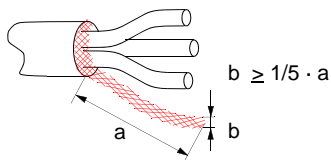

■ Connection procedure

1. Fasten the grounding conductor (PE) of the input power cable under the grounding clamp. Connect the phase conductors to the U1, V1 and W1 terminals. Use a tightening torque of 0.8 N·m (7 lbf·in) for frame sizes R0...R2, 1.7 N·m (15 lbf·in) for R3, and 2.5 N·m (22 lbf·in) for R4.
2. Strip the motor cable and twist the shield to form as short a pigtail as possible. Fasten the twisted shield under the grounding clamp. Connect the phase conductors to the U2, V2 and W2 terminals. Use a tightening torque of 0.8 N·m (7 lbf·in) for frame sizes R0...R2, 1.7 N·m (15 lbf·in) for R3, and 2.5 N·m (22 lbf·in) for R4.
3. Secure the cables outside the drive mechanically.

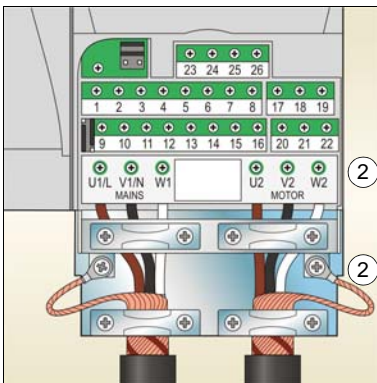
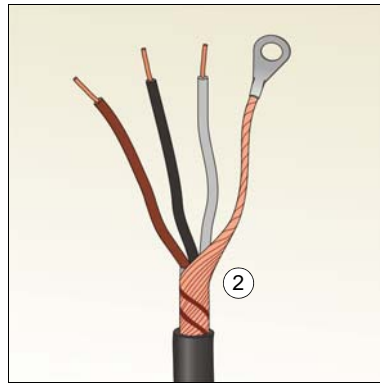
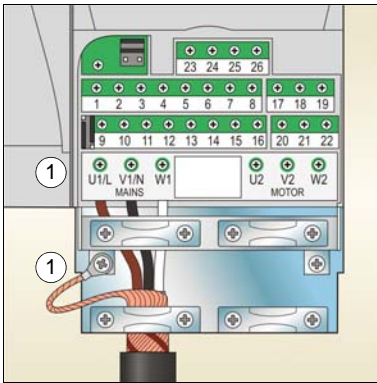

Connecting the control cables

■ Default I/O connection diagram

The default connection of the control signals depends on the application macro in use, which is selected with parameter [9902 APPLIC MACRO](#).

The default macro is the HVAC Default macro. It provides a general purpose I/O configuration with one constant speed. Parameter values are the default values given in chapter *Actual signals and parameters* in *ACS320 User's Manual* (3AUA0000062599 [English]).

The default I/O connections for the HVAC Default macro are given in the figure below.

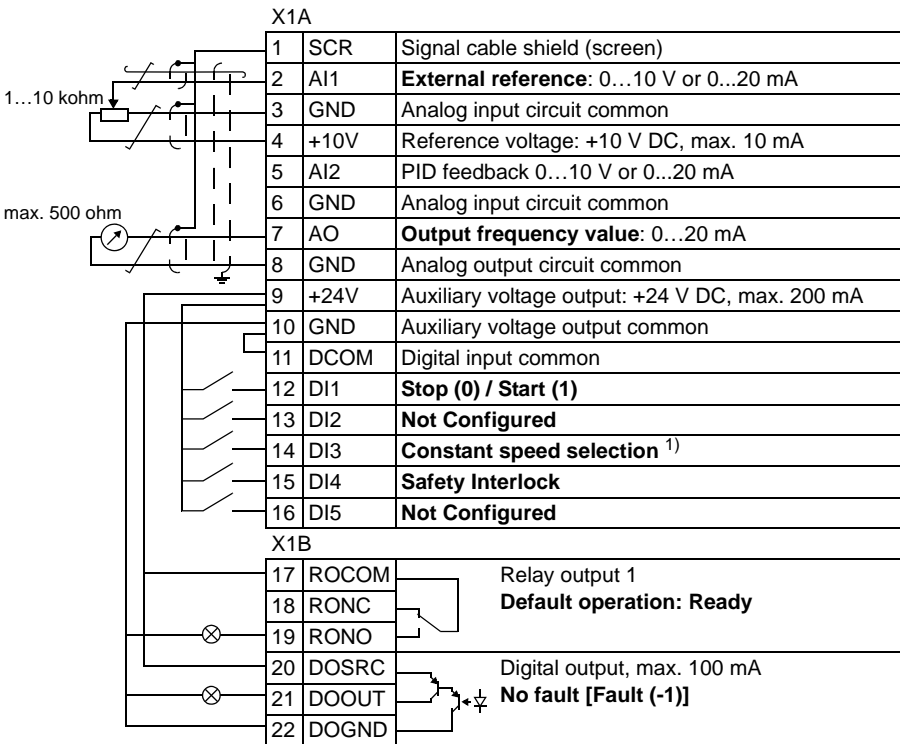

¹⁾ See parameter group [12 CONSTANT SPEEDS](#):

DI3	Operation (parameter)
0	Set speed through AI1
1	Speed 1 (1202)

■ Connection procedure

1. Remove the terminal cover by simultaneously pushing the recess and sliding the cover off the frame.
2. *Digital signals:* Strip the outer insulation of the digital signal cable 360 degrees and ground the bare shield under the clamp.
3. Connect the conductors of the cable to the appropriate terminals. Use a tightening torque of 0.4 N·m (3.5 lbf·in).
4. For double-shielded cables, twist also the grounding conductors of each pair in the cable together and connect the bundle to the SCR terminal (terminal 1).

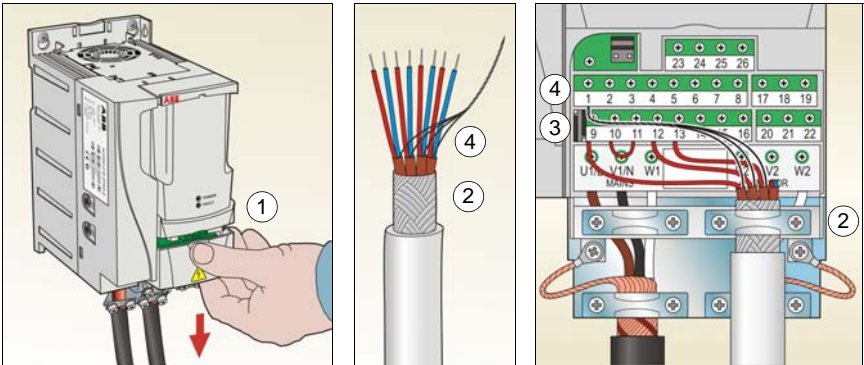

5. *Analog signals:* Strip the outer insulation of the analog signal cable 360 degrees and ground the bare shield under the clamp.
6. Connect the conductors to the appropriate terminals. Use a tightening torque of 0.4 N·m (3.5 lbf·in).
7. Twist the grounding conductors of each pair in the analog signal cable together and connect the bundle to the SCR terminal (terminal 1).
8. Secure all cables outside the drive mechanically.
9. Slide the terminal cover back in place.

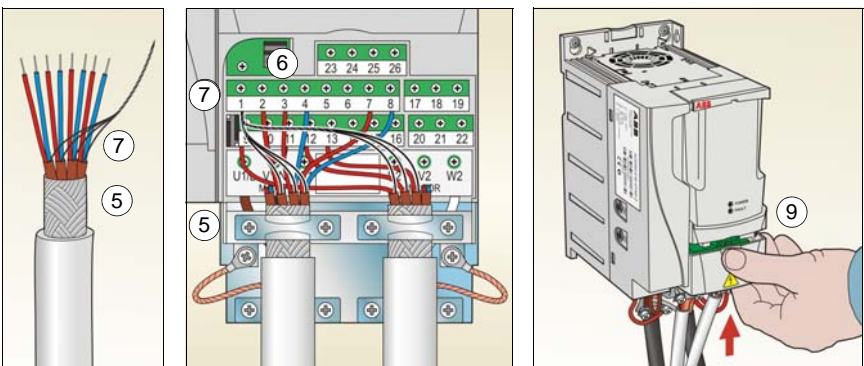

Installation checklist

Check the mechanical and electrical installation of the drive before start-up. Go through the checklist below together with another person. Read chapter [Safety](#) on page [5](#) before you work on the drive.

Check
MECHANICAL INSTALLATION
<ul style="list-style-type: none"> <input type="checkbox"/> The ambient operating conditions are allowed. (See <i>Technical data: Losses, cooling data and noise</i> and <i>Ambient conditions</i> in <i>ACS320 User's Manual</i> (3AUA0000062599 [English]).) <input type="checkbox"/> The drive is fixed properly on an even vertical non-flammable wall. (See Mechanical installation on page 9 and <i>Mechanical installation</i> in <i>ACS320 User's Manual</i> (3AUA0000062599 [English]).) <input type="checkbox"/> The cooling air will flow freely. (See Mechanical installation: Install the drive on page 9.) <input type="checkbox"/> The motor and the driven equipment are ready for start. (See <i>Planning the electrical installation: Checking the compatibility of the motor and drive</i> as well as <i>Technical data: Motor connection data</i> in <i>ACS320 User's Manual</i> (3AUA0000062599 [English]).)
ELECTRICAL INSTALLATION (See Electrical installation on page 13 and <i>Planning the electrical installation</i> in <i>ACS320 User's Manual</i> (3AUA0000062599 [English]).)
<ul style="list-style-type: none"> <input type="checkbox"/> For ungrounded and corner grounded systems: The internal EMC filter is disconnected (EMC screw removed). <input type="checkbox"/> The capacitors are reformed if the drive has been stored over a year. <input type="checkbox"/> The drive is grounded properly. <input type="checkbox"/> The input power voltage matches the drive nominal input voltage. <input type="checkbox"/> The input power connections at U1, V1 and W1 are OK and tightened with the correct torque. <input type="checkbox"/> Appropriate input power fuses and disconnecter are installed. <input type="checkbox"/> The motor connections at U2, V2 and W2 are OK and tightened with the correct torque. <input type="checkbox"/> The motor cable, input power cable and control cables are routed separately. <input type="checkbox"/> The external control (I/O) connections are OK. <input type="checkbox"/> The input power voltage cannot be applied to the output of the drive (with a bypass connection). <input type="checkbox"/> Terminal cover and, for NEMA 1, hood and connection box, are in place.



5. Start-up and control with I/O

How to start up the drive



WARNING! The start-up may only be carried out by a qualified electrician.

The safety instructions given in chapter [Safety](#) on page 5 must be followed during the start-up procedure.

The drive will start up automatically at power up if the external run command is on and the drive is in the remote control mode.

Check that the starting of the motor does not cause any danger. **De-couple the driven machine** if there is a risk of damage in case of incorrect direction of rotation.

Note: By default, parameter [1611](#) PARAMETER VIEW is set to 2 (SHORT VIEW), and you cannot see all actual signals and parameters. To be able to view them, set parameter [1611](#) PARAMETER VIEW to 3 (LONG VIEW).

- Check the installation. See the checklist in chapter *Installation checklist* in *ACS320 User's Manual* (3AUA0000062599 [English]).

How you start up the drive depends on the control panel you have.

- **If you have a Basic Control Panel**, follow the instructions given in section [How to perform a manual start-up](#) on page 20.
- **If you have an Assistant Control Panel**, you can either run the Start-up Assistant (see section [How to perform a guided start-up](#) on page 23) or perform a manual start-up (see section [How to perform a manual start-up](#) on page 20).

The Start-up Assistant, which is included in the Assistant Control Panel only, guides you through all essential settings to be done. In the manual start-up, the drive gives no guidance; you go through the very basic settings by following the instructions given in section [How to perform a manual start-up](#) on page 20.



■ How to perform a manual start-up

For the manual start-up, you can use the Basic Control Panel or the Assistant Control Panel. The instructions below are valid for both control panels, but the displays shown are the Basic Control Panel displays, unless the instruction applies to the Assistant Control Panel only.

Before you start, ensure that you have the motor nameplate data on hand.

POWER-UP

Apply input power.

The Basic Control Panel powers up into the Output mode.

The Assistant Control Panel asks if you want to run the Start-up Assistant. If you press , the Start-up Assistant is not run, and you can continue with manual start-up in a similar manner as described below for the Basic Control Panel.

REM 00 Hz

OUTPUT FWD

OFF ↻ CHOICE

Do you want to use the start-up assistant?

Yes

No

EXIT | 00:00 | OK

MANUAL ENTRY OF START-UP DATA (parameter group 99)

If you have an Assistant Control Panel, select the language (the Basic Control Panel does not support languages). See parameter [9901](#) for the values of the available language alternatives.

For instructions on how to set parameters with the Assistant Control Panel, see chapter *Control panels*, section *Assistant Control Panel* in *ACS320 User's Manual* (3AUA0000062599 [English]).

Enter the motor data from the motor nameplate:

ABB Motors CE

3 ~ motor M2AA 200 MLA 4

IEC 200 M/L 55

No ↶

		Ins.cl. F			IP 55	
v	Hz	kW	r/min	A	cos φ	IA/IN ¹ tE/s
690 Y	50	30	1475	32.5	0.83	
400 D	50	30	1475	56	0.83	
660 Y	50	30	1470	34	0.83	
380 D	50	30	1470	59	0.83	
415 D	50	30	1475	54	0.83	
440 D	60	35	1770	59	0.83	

380 V supply voltage

Cat. no 3GAA 202 001 - ADA

6312/C3 ■ 6210/C3 | 180 kg

IEC 34-1

OFF ↻ PAR EDIT

9901 LANGUAGE

ENGLISH















[0]

CANCEL | 00:00 | SAVE

Note: Set the motor data to exactly the same value as on the motor nameplate. For example, if the motor nominal speed is 1440 rpm on the nameplate, setting the value of parameter 9908 MOTOR NOM SPEED to 1500 rpm results in the wrong operation of the drive.

- motor nominal voltage (parameter [9905](#))

Setting of parameter [9905](#) is shown below as an example of parameter setting with the Basic Control Panel. You find more detailed instructions in chapter *Control panels*, section *Basic Control Panel* in *ACS320 User's Manual* (3AUA0000062599 [English]).

1. To go to the Main menu, press  if the bottom line shows OUTPUT; otherwise press  repeatedly until you see MENU at the bottom.
2. Press keys   until you see "PAR", and press .
3. Find the appropriate parameter group with keys   and press .
4. Find the appropriate parameter in the group with keys  .
5. Press and hold  for about two seconds until the parameter value is shown with **SET** under the value.
6. Change the value with keys  . The value changes faster while you keep the key pressed down.
7. Save the parameter value by pressing .

Enter the rest of the motor data:









- motor nominal current (parameter [9906](#))
Allowed range: $0.2 \dots 2.0 \cdot I_{2N}$ A
- motor nominal frequency (parameter [9907](#))
- motor nominal speed (parameter [9908](#))
- motor nominal power (parameter [9909](#))

- Select the application macro (parameter [9902](#)) according to how the control cables are connected. The default value 1 (HVAC DEFAULT) is suitable in most cases.

REM	9905	PAR	FWD
REM	rEF	MENU	FWD
REM	-01-	PAR	FWD
REM	9901	PAR	FWD
REM	9905	PAR	FWD
REM	400 ^V	PAR	SET FWD
REM	380 ^V	PAR	SET FWD
REM	9905	PAR	FWD
REM	9906	PAR	FWD
REM	9907	PAR	FWD
REM	9908	PAR	FWD
REM	9909	PAR	FWD
REM	9902	PAR	FWD



DIRECTION OF THE MOTOR ROTATION

- Check the direction of the motor rotation.
- If the drive is in remote control (REM shown on the left), switch to local control by pressing .
 - To go to the Main menu, press  if the bottom line shows OUTPUT; otherwise press  repeatedly until you see MENU at the bottom.
 - Press keys / until you see “rEF” and press .
 - Increase the frequency reference from zero to a small value with key .
 - Press  to start the motor.
 - Check that the actual direction of the motor is the same as indicated on the display (FWD means forward and REV reverse).
 - Press  to stop the motor.

To change the direction of the motor rotation:

- If parameter 9914 PHASE INVERSION is not visible, first set parameter **1611** PARAMETER VIEW to 3 (LONG VIEW).
- Invert the phases by changing the value of parameter 9914 to the opposite, ie from 0 (NO) to 1 (YES), or vice versa.
- Verify your work by applying input power and repeating the check as described above. Set parameter 9914 back to 2 (SHORT VIEW).

LOC **XXX** Hz

 FWD

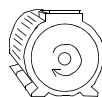

forward
direction

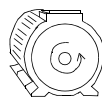

reverse
direction

LOC **1611**

PAR FWD

LOC **9914**

PAR FWD

FINAL CHECK













- Check that the drive state is OK.
- Basic Control Panel: Check that there are no faults or alarms shown on the display. If you want to check the LEDs on the front of the drive, switch first to remote control (otherwise a fault is generated) before removing the panel and verifying that the red LED is not lit and the green LED is lit but not blinking.
- Assistant Control Panel: Check that there are no faults or alarms shown on the display and that the panel LED is green and does not blink.

The drive is now ready for use.



















■ How to perform a guided start-up

To be able to perform the guided start-up, you need the Assistant Control Panel.

Before you start, ensure that you have the motor nameplate data on hand.

POWER-UP	
<input type="checkbox"/> Apply input power. The control panel first asks if you want to use the Start-up Assistant. <ul style="list-style-type: none"> • Press  (when Yes is highlighted) to run the Start-up Assistant. • Press  if you do not want to run the Start-up Assistant. • Press key  to highlight No and then press  if you want to make the panel ask (or not ask) the question about running the Start-up Assistant again the next time you switch on the power to the drive. 	<div style="border: 1px solid black; padding: 5px;"> OFF CHOICE Do you want to use the start-up assistant? Yes No EXIT 00:00 OK </div> <div style="border: 1px solid black; padding: 5px;"> OFF CHOICE Show start-up assistant on next boot? Yes No EXIT 00:00 OK </div>
SELECTING THE LANGUAGE	
<input type="checkbox"/> If you decided to run the Start-up Assistant, the display then asks you to select the language. Scroll to the desired language with keys   and press  to accept. If you press  , the Start-up Assistant is stopped.	<div style="border: 1px solid black; padding: 5px;"> OFF PAR EDIT 9901 LANGUAGE ENGLISH [0] EXIT 00:00 SAVE </div>
STARTING THE GUIDED SET-UP	
<input type="checkbox"/> The Start-up Assistant now guides you through the set-up tasks, starting with the motor set-up. Set the motor data to exactly the same value as on the motor nameplate. Scroll to the desired parameter value with keys   and press  to accept and continue with the Start-up Assistant. Note: At any time, if you press  , the Start-up Assistant is stopped and the display goes to the Output mode.	<div style="border: 1px solid black; padding: 5px;"> OFF PAR EDIT 9905 MOTOR NOM VOLT 220 V EXIT 00:00 SAVE </div>
<input type="checkbox"/> The basic start-up is now completed. However, it might be useful at this stage to set the parameters required by your application and continue with the application set-up as suggested by the Start-up Assistant.	<div style="border: 1px solid black; padding: 5px;"> OFF CHOICE Do you want to continue with application setup? Continue Skip EXIT 00:00 OK </div>



<p><input type="checkbox"/> Select the application macro according to which the control cables are connected.</p> <p>Continue with the application set-up. After completing a set-up task, the Start-up Assistant suggests the next one.</p> <ul style="list-style-type: none"> • Press  (when Continue is highlighted) to continue with the suggested task. • Press key  to highlight Skip and then press  to move to the following task without doing the suggested task. • Press  to stop the Start-up Assistant. 	<div data-bbox="711 143 968 279"> <p>OFF  PAR EDIT</p> <p>9902 APPLIC MACRO</p> <p>HVAC DEFAULT</p> <p>[1]</p> <p>EXIT 00:00 SAVE</p> </div> <div data-bbox="711 295 968 430"> <p>OFF  CHOICE</p> <p>Do you want to continue with EXT1 reference setup?</p> <p>Continue</p> <p>Skip</p> <p>EXIT 00:00 OK</p> </div>
<p>DIRECTION OF THE MOTOR ROTATION</p>	
<p><input type="checkbox"/> Check the direction of the motor rotation.</p> <ul style="list-style-type: none"> • If the drive is in remote control (AUTO shown on the status line), switch to local control by pressing . • If you are not in the Output mode, press  repeatedly until you get there. • Increase the frequency reference from zero to a small value with key . • Press  to start the motor. • Check that the actual direction of the motor is the same as indicated on the display ( means forward and  reverse). • Press  to stop the motor. <p>To change the direction of the motor rotation:</p> <ul style="list-style-type: none"> • If parameter 9914 PHASE INVERSION is not visible, first set parameter 1611 PARAMETER VIEW to 3 (LONG VIEW). • Invert the phases by changing the value of parameter 9914 to the opposite, ie from 0 (NO) to 1 (YES), or vice versa. • Verify your work by applying input power and repeating the check as described above. • Set parameter 9914 back to 2 (SHORT VIEW). 	<div data-bbox="711 662 968 798"> <p>OFF  xx. xHZ</p> <p>xx. x HZ</p> <p>x. x A</p> <p>xx. x %</p> <p>DIR 00:00 MENU</p> </div> <div data-bbox="711 925 968 1069"> <div style="display: flex; justify-content: space-around;"> <div style="text-align: center;">  <p>forward direction</p> </div> <div style="text-align: center;">  <p>reverse direction</p> </div> </div> </div> <div data-bbox="711 1117 968 1252"> <p>OFF  PAR EDIT</p> <p>1611 PARAMETER VIEW</p> <p>LONG VIEW</p> <p>[3]</p> <p>CANCEL 00:00 SAVE</p> </div> <div data-bbox="711 1268 968 1404"> <p>OFF  PAR EDIT</p> <p>9914 PHASE INVERSION</p> <p>YES</p> <p>[1]</p> <p>CANCEL 00:00 SAVE</p> </div>



FINAL CHECK

- | | |
|--------------------------|---|
| <input type="checkbox"/> | After the whole set-up is completed, check that there are no faults or alarms shown on the display and the panel LED is green and does not blink. |
|--------------------------|---|

The drive is now ready for use.



How to control the drive through the I/O interface

The table below instructs how to operate the drive through the digital and analog inputs when:

- the motor start-up is performed, and
- the default (standard) parameter settings are valid.

Displays of the Basic Control Panel are shown as an example.

PRELIMINARY SETTINGS							
<p>If you need to change the direction of rotation, check that parameter 1003 DIRECTION is set to 3 (REQUEST).</p> <p>Ensure that the control connections are wired according to the connection diagram given for the HVAC Default macro.</p> <p>Ensure that the drive is in remote control. Press key  to switch between remote and local control.</p>	<p>See section Default I/O connection diagram on page 16.</p> <p>In remote control, the panel display shows text REM.</p>						
STARTING AND CONTROLLING THE SPEED OF THE MOTOR							
<p>Start by switching digital input DI1 on.</p> <p><u>Basic Control Panel:</u> Text FWD starts flashing fast and stops after the setpoint is reached</p> <p><u>Assistant Control Panel:</u> The arrow starts rotating. It is dotted until the setpoint is reached.</p> <p>Regulate the drive output frequency (motor speed) by adjusting the voltage of analog input AI1.</p>	<table border="1" style="width: 100%; text-align: center;"> <tr> <td style="padding: 5px;">REM OUTPUT</td> <td style="font-size: 2em; padding: 10px;">00</td> <td style="padding: 5px;">Hz FWD</td> </tr> </table> <table border="1" style="width: 100%; text-align: center;"> <tr> <td style="padding: 5px;">REM OUTPUT</td> <td style="font-size: 2em; padding: 10px;">500</td> <td style="padding: 5px;">Hz FWD</td> </tr> </table>	REM OUTPUT	00	Hz FWD	REM OUTPUT	500	Hz FWD
REM OUTPUT	00	Hz FWD					
REM OUTPUT	500	Hz FWD					
CHANGING THE DIRECTION OF ROTATION OF THE MOTOR							
<p>Reverse direction: Switch digital input DI2 on.</p> <p>Forward direction: Switch digital input DI2 off.</p>	<table border="1" style="width: 100%; text-align: center;"> <tr> <td style="padding: 5px;">REM OUTPUT</td> <td style="font-size: 2em; padding: 10px;">500</td> <td style="padding: 5px;">Hz REV</td> </tr> </table> <table border="1" style="width: 100%; text-align: center;"> <tr> <td style="padding: 5px;">REM OUTPUT</td> <td style="font-size: 2em; padding: 10px;">500</td> <td style="padding: 5px;">Hz FWD</td> </tr> </table>	REM OUTPUT	500	Hz REV	REM OUTPUT	500	Hz FWD
REM OUTPUT	500	Hz REV					
REM OUTPUT	500	Hz FWD					
STOPPING THE MOTOR							
<p>Switch digital input DI1 off. The motor stops.</p> <p><u>Basic Control Panel:</u> Text FWD starts flashing slowly.</p> <p><u>Assistant Control Panel:</u> The arrow stops rotating.</p>	<table border="1" style="width: 100%; text-align: center;"> <tr> <td style="padding: 5px;">REM OUTPUT</td> <td style="font-size: 2em; padding: 10px;">00</td> <td style="padding: 5px;">Hz FWD</td> </tr> </table>	REM OUTPUT	00	Hz FWD			
REM OUTPUT	00	Hz FWD					



6. Actual signals and parameters in the short view

Note: When the control panel is in the short parameter view, ie when parameter 1611 PARAMETER VIEW is set to 2 (SHORT VIEW), the control panel only shows a subset of all signals and parameters. These signals and parameters are described in this chapter.

To be able to view all actual signals and parameters, set parameter 1611 PARAMETER VIEW to 3 (LONG VIEW). For the description of all actual signals and parameters, refer to chapter *Actual signals and parameters* in *ACS320 User's Manual* (3AUA0000062599 [English]).

Terms and abbreviations

Term	Definition
Actual signal	Signal measured or calculated by the drive. Can be monitored by the user. No user setting possible. Groups 01...04 contain actual signals.
Def	Parameter default value
Parameter	A user-adjustable operation instruction of the drive. Groups 10...99 contain parameters. Note: Parameter selections are shown on the Basic Control Panel as integer values. Eg parameter 1001 EXT1 COMMANDS selection COMM is shown as value 10 (which is equal to the fieldbus equivalent FbEq).
FbEq	Fieldbus equivalent: The scaling between the value and the integer used in serial communication.
E	Refers to types 03E- with European parametrization
U	Refers to types 03U- with US parametrization

Fieldbus equivalent

Example: If [2008](#) MAXIMUM FREQ (see page [32](#)) is set from an external control system, an integer value of 1 corresponds to 0.1 Hz. All the read and sent values are limited to 16 bits (-32768...32767).

Default values with different macros

When application macro is changed ([9902](#) APPLIC MACRO), the software updates the parameter values to their default values. The tables below include the parameter default values for different macros. For other parameters, the default values are the same for all macros. See the parameter list starting on page [31](#) in this manual and chapter *Actual signals and parameters* in *ACS320 User's Manual* (3AUA0000062599 [English]).

Index	Name/Selection	HVAC default	Supply Fan	Return Fan	Cooling Tower Fan	Condenser	Booster Pump	Pump Fan Alternation	Internal Timer
9902	APPLIC MACRO	HVAC DEFAULT	SUPPLY FAN	RETURN FAN	CLNG TWR FAN	CONDENSER	BOOSTER PUMP	PUMP ALTERNA	INT TIMER
1001	EXT1 COMMANDS	DI1	DI1	DI1	DI1	DI1	DI1	DI1	TIMER1
1002	EXT2 COMMANDS	DI1	DI1	DI1	DI1	DI1	DI1	DI1	TIMER1
1102	EXT1/EXT2 SEL	EXT1	EXT1	EXT1	EXT1	EXT1	EXT1	EXT1	EXT1
1103	REF1 SEL	AI1	AI1	AI1	AI1	AI1	AI1	AI1	AI1
1106	REF2 SEL	PID1OUT	PID1OUT	PID1OUT	PID1OUT	PID1OUT	PID1OUT	PID1OUT	PID1OUT
1201	CONST SPEED SEL	DI3	DI3	DI3	DI3	DI3	DI3	NOT SEL	NOT SEL
1401	RELAY OUTPUT 1	READY	STARTED	STARTED	READY	READY	READY	PFA	STARTED
1601	RUN ENABLE	NOT SEL	DI2	NOT SEL	NOT SEL	NOT SEL	NOT SEL	NOT SEL	DI2
1608	START ENABLE 1	DI4	DI4	DI4	DI4	DI4	DI4	NOT SEL	DI4
1609	START ENABLE 2	NOT SEL	DI5	DI5	NOT SEL	NOT SEL	NOT SEL	NOT SEL	DI5
2007	MINIMUM FREQ	0.0 Hz	0.0 Hz	0.0 Hz	20.0 Hz	0.0 Hz	0.0 Hz	0.0 Hz	0.0 Hz
2101	START FUNCTION	SCAN START	SCAN START	SCAN START	SCAN START	SCAN START	AUTO	AUTO	SCAN START
2108	START INHIBIT	OFF	OFF	OFF	OFF	OFF	OFF	OFF	OFF
2202	ACCELER TIME 1	30.0 s	30.0 s	30.0 s	30.0 s	30.0 s	10.0 s	10.0 s	30.0 s
2203	DECELER TIME 1	30.0 s	30.0 s	30.0 s	30.0 s	30.0 s	10.0 s	10.0 s	30.0 s
3415	SIGNAL 3 PARAM	AI 1	AI 1	AI 1	AI 1	AI 1	AI 1	AI 1	AI 1
3416	SIGNAL 3 MIN	-100.0%	-100.0%	-100.0%	-100.0%	-100.0%	-100.0%	-100.0%	-100.0%
3417	SIGNAL 3 MAX	100.0%	100.0%	100.0%	100.0%	100.0%	100.0%	100.0%	100.0%
3419	OUTPUT 3 DSP UNIT	mA	mA	mA	mA	mA	mA	mA	mA
3420	OUTPUT 3 MIN	0.0 mA	0.0 mA	0.0 mA	0.0 mA	0.0 mA	0.0 mA	0.0 mA	0.0 mA
3421	OUTPUT 3 MAX	20.0 mA	20.0 mA	20.0 mA	20.0 mA	20.0 mA	20.0 mA	20.0 mA	20.0 mA
3601	TIMERS ENABLE	NOT SEL	NOT SEL	NOT SEL	NOT SEL	NOT SEL	NOT SEL	NOT SEL	DI1
3622	BOOST SEL	NOT SEL	NOT SEL	NOT SEL	NOT SEL	NOT SEL	NOT SEL	NOT SEL	DI3
3626	TIMER 1 SRC	NOT SEL	NOT SEL	NOT SEL	NOT SEL	NOT SEL	NOT SEL	NOT SEL	(B+P3+P2+P1)
4005	ERROR VALUE INV	NO	NO	NO	YES	YES	NO	NO	NO
4010	SETPOINT SEL	KEYPAD	KEYPAD	KEYPAD	KEYPAD	KEYPAD	KEYPAD	KEYPAD	KEYPAD
4011	INTERNAL SETPNT	40.0%	40.0%	40.0%	40.0%	40.0%	40.0%	40.0%	40.0%
4027	PID 1 PARAM SET	SET 1	SET 1	SET 1	SET 1	SET 1	SET 1	SET 1	SET 1
4110	SETPOINT SEL	KEYPAD	KEYPAD	KEYPAD	KEYPAD	KEYPAD	KEYPAD	KEYPAD	KEYPAD
4111	INTERNAL SETPNT	40.0%	40.0%	40.0%	40.0%	40.0%	40.0%	40.0%	40.0%
5303	EFBBAUD RATE	9.6 kb/s	9.6 kb/s	9.6 kb/s	9.6 kb/s	9.6 kb/s	9.6 kb/s	9.6 kb/s	9.6 kb/s
5304	EFB PARITY	8 NONE 1	8 NONE 1	8 NONE 1	8 NONE 1	8 NONE 1	8 NONE 1	8 NONE 1	8 NONE 1
5305	EFB CTRL PROFILE	ABB DRV LIM	ABB DRV LIM	ABB DRV LIM	ABB DRV LIM	ABB DRV LIM	ABB DRV LIM	ABB DRV LIM	ABB DRV LIM
8109	START FREQ 1	60.0 Hz	60.0 Hz	60.0 Hz	60.0 Hz	60.0 Hz	60.0 Hz	58.0 Hz	60.0 Hz
8110	START FREQ 2	60.0 Hz	60.0 Hz	60.0 Hz	60.0 Hz	60.0 Hz	60.0 Hz	58.0 Hz	60.0 Hz
8111	START FREQ 3	60.0 Hz	60.0 Hz	60.0 Hz	60.0 Hz	60.0 Hz	60.0 Hz	58.0 Hz	60.0 Hz
8123	PFA ENABLE	NOT SEL	NOT SEL	NOT SEL	NOT SEL	NOT SEL	NOT SEL	ACTIVE	NOT SEL

Actual signals in the short parameter view

Actual signals			
No.	Name/Value	Description	FbEq
04 FAULT HISTORY			
Fault history (read-only)			
0401	LAST FAULT	Code of the latest fault. See chapter <i>Fault tracing</i> in <i>ACS320 User's Manual</i> (3AUA0000062599 [English]) for the codes. 0 = Fault history is clear (on panel display = NO RECORD).	1 = 1

Parameters in the short parameter view

Parameters			
No.	Name/Value	Description	Default
11 REFERENCE SELECT			
Panel reference type, external control location selection and external reference sources and limits			
1105	REF1 MAX	Defines the maximum value for external reference REF1. Corresponds to the maximum setting of the used source signal.	E: 50.0 Hz U: 60.0 Hz
	0.0...500.0 Hz	Maximum value in Hz. See the example for parameter 1104 REF1 MIN in <i>ACS320 User's Manual</i> (3AUA0000062599 [English]).	1 = 0.1 Hz
12 CONSTANT SPEEDS			
Constant speed (drive output frequency) selection and values. By default constant speed selection is made through digital input DI3. 1 = DI active, 0 = DI inactive.			
DI3 Operation			
0 No constant speed			
1 Speed defined by parameter 1202 CONST SPEED 1			
For more information, see chapter <i>Program features</i> , section <i>Constant speeds</i> in <i>ACS320 User's Manual</i> (3AUA0000062599 [English]).			
1202	CONST SPEED 1	Defines constant drive output frequency 1.	E: 5.0 Hz U: 6.0 Hz
	0.0...500.0 Hz	Output frequency in Hz.	1 = 0.1 Hz
1203	CONST SPEED 2	Defines constant drive output frequency 2.	E: 10.0 Hz U: 12.0 Hz
	0.0...500.0 Hz	Output frequency in Hz.	1 = 0.1 Hz
1204	CONST SPEED 3	Defines constant drive output frequency 3.	E: 15.0 Hz U: 18.0 Hz
	0.0...500.0 Hz	Output frequency in Hz.	1 = 0.1 Hz

Parameters			
No.	Name/Value	Description	Default
13 ANALOG INPUTS			Analog input signal processing
1301	MINIMUM AI1	<p>Defines the minimum %-value that corresponds to minimum mA/(V) signal for analog input AI1. When used as a reference, the value corresponds to the reference minimum setting.</p> <p>0...20 mA $\hat{=}$ 0...100% 4...20 mA $\hat{=}$ 20...100% -10...10 mA $\hat{=}$ -50...50%</p> <p>Example: If AI1 is selected as the source for external reference REF1, this value corresponds to the value of parameter 1104 REF1 MIN.</p> <p>Note: MINIMUM AI value must not exceed MAXIMUM AI value.</p>	1.0%
	-100.0... 100.0%	Value as a percentage of the full signal range. Example: If the minimum value for analog input is 4 mA, the percent value for 0...20 mA range is: $(4 \text{ mA} / 20 \text{ mA}) \cdot 100\% = 20\%$	1 = 0.1%
14 RELAY OUTPUTS			Status information indicated through relay output, and relay operating delays. For more information, see chapter <i>Actual signals and parameters</i> in <i>ACS320 User's Manual</i> (3AUA0000062599 [English]).
1401	RELAY OUTPUT 1	Selects a drive status indicated through relay output RO 1. The relay energizes when the status meets the setting.	READY
	NOT SEL	Not used	0
	READY	Ready to function: Run Enable signal on, no fault, supply voltage within acceptable range and emergency stop signal off.	1
	RUN	Running: Start signal on, Run Enable signal on, no active fault.	2
	FAULT(-1)	Inverted fault. Relay is de-energized on a fault trip.	3
16 SYSTEM CONTROLS			Parameter view, Run Enable, parameter lock etc.
1611	PARAMETER VIEW	Selects the parameter view, ie which parameters are shown on the control panel.	SHORT VIEW
	FLASHDROP	Shows the FlashDrop parameter list. Does not include the short parameter list. Parameters which are hidden by the FlashDrop device are not visible. FlashDrop parameter values are activated by setting parameter 9902 APPLIC MACRO to 31 (LOAD FD SET).	1
	SHORT VIEW	Shows only those signals and parameters that are listed in this table.	2
	LONG VIEW	Shows all signals and parameters.	3
20 LIMITS			Drive operation limits.
2008	MAXIMUM FREQ	Defines the maximum limit for the drive output frequency.	E: 50.0 Hz U: 60.0 Hz
	0.0...500.0 Hz	Maximum frequency	1 = 0.1 Hz
21 START/STOP			Start and stop modes of the motor
2102	STOP FUNCTION	Selects the motor stop function.	COAST

Parameters			
No.	Name/Value	Description	Default
	COAST	Stop by cutting off the motor power supply. The motor coasts to a stop.	1
	RAMP	Stop along a ramp. See parameter group 22 ACCEL/DECEL .	2
22 ACCEL/DECEL			Acceleration and deceleration times
2202	ACCELER TIME 1	<p>Defines the acceleration time 1, ie the time required for the speed to change from zero to the speed defined by parameter 2008 MAXIMUM FREQ.</p> <ul style="list-style-type: none"> - If the speed reference increases faster than the set acceleration rate, the motor speed will follow the acceleration rate. - If the speed reference increases slower than the set acceleration rate, the motor speed will follow the reference signal. - If the acceleration time is set too short, the drive will automatically prolong the acceleration in order not to exceed the drive operating limits. <p>Actual acceleration time depends on parameter 2204 RAMP SHAPE 1 setting.</p>	5.0 s
	0.0...1800.0 s	Time	1 = 0.1 s
2203	DECELER TIME 1	<p>Defines the deceleration time 1, ie the time required for the speed to change from the value define by parameter 2008 MAXIMUM FREQ to zero.</p> <ul style="list-style-type: none"> - If the speed reference decreases slower than the set deceleration rate, the motor speed will follow the reference signal. - If the reference changes faster than the set deceleration rate, the motor speed will follow the deceleration rate. - If the deceleration time is set too short, the drive will automatically prolong the deceleration in order not to exceed drive operating limits. <p>If a short deceleration time is needed for a high inertia application, note that the ACS310 cannot be equipped with a brake resistor.</p> <p>Actual deceleration time depends on parameter 2204 RAMP SHAPE 1 setting.</p>	5.0 s
	0.0...1800.0 s	Time	1 = 0.1 s
99 START-UP DATA			Language selection. Definition of motor set-up data.
9901	LANGUAGE	<p>Selects the display language.</p> <p>Note: With the ACS-CP-D Assistant Control Panel, the following languages are available: English (0), Chinese (1), Korean (2) and Japanese (3).</p>	ENGLISH
	ENGLISH	British English	0
	ENGLISH (AM)	American English	1
	DEUTSCH	German	2
	ITALIANO	Italian	3
	ESPAÑOL	Spanish	4
	PORTUGUES	Portuguese	5
	NEDERLANDS	Dutch	6

Parameters			
No.	Name/Value	Description	Default
	FRANÇAIS	French	7
	DANSK	Danish	8
	SUOMI	Finnish	9
	SVENSKA	Swedish	10
	RUSSKI	Russian	11
	POLSKI	Polish	12
	TÜRKÇE	Turkish	13
	CZECH	Czech	14
	MAGYAR	Hungarian	15
9902	APPLIC MACRO	Selects the application macro. See chapter <i>Application macros</i> in <i>ACS320 User's Manual (3AUA0000062599 [English])</i> .	HVAC DEFAULT
	HVAC Default	This macro provides the factory default parameter settings for the ACS320.	1
	Supply Fan	For supply fan applications where the supply fan brings fresh air in.	2
	Return Fan	For return fan applications where the return fan removes air.	3
	Cooling Tower Fan	For cooling tower fan applications.	4
	Condenser	For condenser and liquid cooler applications.	5
	Booster Pump	For booster pump applications.	6
	Pump Alternation	For pump and fan alternation (PFA) applications.	7
	Internal Timer	For applications where a built-in timer starts and stops the motor.	8
	Internal Timer w/ Constant Speeds	For applications such as a timed powered roof ventilator (PRV) which alternates between two constant speeds (constant speed 1 and 2) based on a built-in timer.	9
	Floating Point	For applications where speed reference needs to be controlled through digital inputs (DI4 & DI5). By activating digital input 4, the speed reference increases, by activating digital input 5, the speed reference decreases. If both digital inputs are active or inactive, the reference does not change.	10
	Dual Setpoint PID	For dual setpoint PID applications, where activating digital input 3 (DI3) changes the process PID controller's setpoint to another value.	11
	Dual Setpoint PID w/ Constant Speeds	For applications with 2 constant speeds, active PID and PID alternating between two setpoints using digital inputs.	12
	E-Bypass	This macro provides the equivalent ACH550 E-Bypass default parameter settings for the ACS320. (The ACS320 is not physically compatible with the E-Bypass.)	13
	Hand Control	For drive control using only the control panel with no automated control.	14
	E-Clipse	This macro provides the equivalent ACH550 E-Clipse Bypass default parameter settings for the ACS320. (The ACS320 is not compatible with the E-Clipse Bypass.)	15

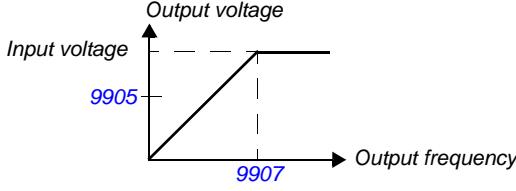
Parameters			
No.	Name/Value	Description	Default
	LOAD FD SET	FlashDrop parameter values as defined by the FlashDrop file. Parameter view is selected by parameter 1611 PARAMETER VIEW. FlashDrop is an optional device for fast copying of parameters to unpowered drives. FlashDrop allows easy customization of the parameter list, eg selected parameters can be hidden. For more information, see MFDT-01 FlashDrop User's Manual (3AFE68591074 [English]).	31
	USER S1 LOAD	User 1 macro loaded into use. Before loading, check that the saved parameter settings and the motor model are suitable for the application.	0
	USER S1 SAVE	Save User 1 macro. Stores the current parameter settings and the motor model.	-1
	USER S2 LOAD	User 2 macro loaded into use. Before loading, check that the saved parameter settings and the motor model are suitable for the application.	-2
	USER S2 SAVE	Save User 2 macro. Stores the current parameter settings and the motor model.	-3
9905	MOTOR NOM VOLT	Defines the nominal motor voltage. Must be equal to the value on the motor rating plate. The drive cannot supply the motor with a voltage greater than the input power voltage.  <p>WARNING! Never connect a motor to a drive which is connected to power line with voltage level higher than the rated motor voltage.</p>	230 V (200 V units) 400 V (400 V E units) 460 V (400 V U units)
	115...345 V (200 V units) 200...600 V (400 V E units) 230...690 V (400 V U units)	Voltage. Note: The stress on the motor insulations is always dependent on the drive supply voltage. This also applies to the case where the motor voltage rating is lower than the rating of the drive and the supply of the drive.	1 = 1 V
9906	MOTOR NOM CURR	Defines the nominal motor current. Must be equal to the value on the motor rating plate.	I_{2N}
	0.2...2.0 · I_{2N}	Current	1 = 0.1 A
9907	MOTOR NOM FREQ	Defines the nominal motor frequency, ie the frequency at which the output voltage equals the motor nominal voltage: Field weakening point = Nom. frequency · Supply voltage / Motor nom. voltage	E: 50.0 Hz U: 60.0 Hz
	10.0...500.0 Hz	Frequency	1 = 0.1 Hz
9908	MOTOR NOM SPEED	Defines the nominal motor speed. Must be equal to the value on the motor rating plate.	Type dependent
	50...18000 rpm	Speed	1 = 1 rpm

Parameters			
No.	Name/Value	Description	Default
9909	MOTOR NOM POWER	Defines the nominal motor power. Must equal the value on the motor rating plate.	P_N
	0.2...3.0 · P_N kW	Power	1 = 0.1 kW/hp

7. Technical data

Ratings

Type ACS320- x = E/U ¹⁾	Input	Output			Frame size
	I_{IN} A	I_{LD} A	I_{2N} A	I_{2max} A	
1-phase $U_N = 200...240$ V (200, 208, 220, 230, 240 V)					
01x-02A4-2	6.1	2.3	2.4	4.0	R0
01x-04A7-2	11.4	4.5	4.7	7.9	R1
01x-06A7-2	16.1	6.5	6.7	11.4	R1
01x-07A5-2	16.8	7.2	7.5	12.6	R2
01x-09A8-2	21.0	9.4	9.8	16.5	R2
3-phase $U_N = 200...240$ V (200, 208, 220, 230, 240 V)					
03x-02A6-2	4.7	2.4	2.6	4.2	R0
03x-03A9-2	6.7	3.5	3.9	6.1	R0
03x-05A2-2	8.4	4.7	5.2	8.2	R1
03x-07A4-2	13.0	6.7	7.4	11.7	R1
03x-08A3-2	13.2	7.5	8.3	13.1	R1
03x-10A8-2	15.7	9.8	10.8	17.2	R2
03x-14A6-2	23.9	13.3	14.6	23.3	R2
03x-19A4-2	27.3	17.6	19.4	30.8	R2
03x-26A8-2	45	24.4	26.8	42.7	R3
03x-34A1-2	55	31.0	34.1	54.3	R4
03x-50A8-2	76	46.2	50.8	80.9	R4
3-phase $U_N = 380...480$ V (380, 400, 415, 440, 460, 480 V)					
03x-01A2-4	2.2	1.1	1.2	2.1	R0
03x-01A9-4	3.6	1.7	1.9	3.3	R0
03x-02A4-4	4.1	2.2	2.4	4.2	R1
03x-03A3-4	6	3.0	3.3	5.8	R1
03x-04A1-4	6.9	3.7	4.1	7.2	R1
03x-05A6-4	9.6	5.1	5.6	9.8	R1
03x-07A3-4	11.6	6.6	7.3	12.8	R1
03x-08A8-4	13.6	8.0	8.8	15.4	R1
03x-12A5-4	18.8	11.4	12.5	21.9	R3
03x-15A6-4	22.1	14.2	15.6	27.3	R3
03x-23A1-4	30.9	21.0	23.1	40.4	R3
03x-31A0-4	52	28.2	31	54.3	R4
03x-38A0-4	61	34.5	38	66.5	R4
03x-44A0-4	67	40.0	44	77.0	R4

¹⁾ E = built-in EMC,
U = US version (non-connected EMC, US parametrization)

■ Symbols

I_{1N}	Input current at nominal load (100%) in +40 °C ambient, THD = 180%
I_{LD}	Output current at +50 °C ambient temperature.
I_{2N}	Maximum continuous output current, 1.1* I_{LD} available in +40 °C ambient temperature. Derating up to 50 °C 1% per degree.
I_{2max}	Maximum instantaneous output current, available 2.0 seconds every 10th minute.
R0...R4	ACS320 is manufactured in frame sizes R0...R4. Some instructions and other information that only concern certain frame sizes are marked with the symbol of the frame size (R0...R4)

For information on derating, see chapter *Technical data*, section *Derating* in *ACS320 User's Manual* (3AUA0000062599 [English]).

Power cable sizes and fuses

Note: Larger fuses must not be used.

Type ACS320- x = E/U	Fuses		Size of copper conductor in cabling					
	gG	UL Class T (600 V) A	Supply (U1, V1, W1)		Motor (U2, V2, W2)		PE	
			mm ²	AWG	mm ²	AWG	mm ²	AWG
1-phase $U_N = 200...240$ V (200, 208, 220, 230, 240 V)								
01x-02A4-2	10	10	2.5	14	0.75	18	2.5	14
01x-04A7-2	16	20	2.5	14	0.75	18	2.5	14
01x-06A7-2	16/20*	25	2.5	10	1.5	14	2.5	10
01x-07A5-2	20/25*	30	2.5	10	1.5	14	2.5	10
01x-09A8-2	25/35*	35	6	10	2.5	12	6	10
3-phase $U_N = 200...240$ V (200, 208, 220, 230, 240 V)								
03x-02A6-2	10	10	2.5	14	1.5	14	2.5	14
03x-03A9-2	10	10	2.5	14	1.5	14	2.5	14
03x-05A2-2	10	15	2.5	14	1.5	14	2.5	14
03x-07A4-2	16	15	2.5	12	1.5	14	2.5	12
03x-08A3-2	16	15	2.5	12	1.5	14	2.5	12
03x-10A8-2	16	20	2.5	12	2.5	12	2.5	12
03x-14A6-2	25	30	6	10	6	10	6	10
03x-19A4-2	25	35	6	10	6	10	6	10
03x-26A8-2	63	60	10	8	10	8	10	8
03x-34A1-2	80	80	16	6	16	6	16	6
03x-50A8-2	100	100	25	2	25	2	16	4
3-phase $U_N = 380...480$ V (380, 400, 415, 440, 460, 480 V)								
03x-01A2-4	10	10	2.5	14	1.5	14	2.5	14
03x-01A9-4	10	10	2.5	14	1.5	14	2.5	14
03x-02A4-4	10	10	2.5	14	1.5	14	2.5	14
03x-03A3-4	10	10	2.5	12	1.5	14	2.5	12
03x-04A1-4	16	15	2.5	12	1.5	14	2.5	12
03x-05A6-4	16	15	2.5	12	1.5	14	2.5	12
03x-07A3-4	16	20	2.5	12	1.5	14	2.5	12
03x-08A8-4	20	25	2.5	12	2.5	12	2.5	12
03x-12A5-4	25	30	6	10	6	10	6	10
03x-15A6-4	35	35	6	8	6	8	6	8
03x-23A1-4	50	50	10	8	10	8	10	8
03x-31A0-4	80	80	16	6	16	6	16	6
03x-38A0-4	100	100	25	4	16	4	16	4
03x-44A0-4	100	100	25	4	25	4	16	4

* If 150% output is needed select higher fuse value from the table

UL checklist

The UL mark is attached to the drive to verify that it meets UL requirements.

See the instructions for electrical installation in the sections in this manual or in the *ACS320 User's Manual* (3AUA0000062599 [English]) specified below.

Input power connection – See *ACS320 User's Manual*, chapter *Technical data*, section *Electric power network specification*.

Disconnecting device (disconnecting means) – See *ACS320 User's Manual*, chapter *Planning the electrical installation*, section *Selecting the supply disconnecting device (disconnecting means)*.

Ambient conditions – The drives are to be used in a heated indoor controlled environment. See *ACS320 User's Manual*, chapter *Technical data*, section *Ambient conditions* for specific limits.

Input cable fuses – For installation in the United States, branch circuit protection must be provided in accordance with the National Electrical Code (NEC) and any applicable local codes. To fulfil this requirement, use the UL classified fuses given in section [Power cable sizes and fuses](#) on page 39.

For installation in Canada, branch circuit protection must be provided in accordance with Canadian Electrical Code and any applicable provincial codes. To fulfil this requirement, use the UL classified fuses given in section [Power cable sizes and fuses](#) on page 39.

Power cable selection – See *ACS320 User's Manual*, chapter *Planning the electrical installation*, section *Selecting the power cables*.

Power cable connections – For the connection diagram and tightening torques, see section [Connecting the power cables](#) on page 14.

Overload protection – The drive provides overload protection in accordance with the National Electrical Code (US).

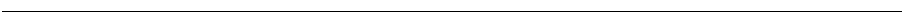

Further information

Product and service inquiries

Address any inquiries about the product to your local ABB representative, quoting the type designation and serial number of the unit in question. A listing of ABB sales, support and service contacts can be found by navigating to www.abb.com/drives and selecting *Sales, Support and Service Network*.

Product training

For information on ABB product training, navigate to www.abb.com/drives and select *Training courses*.

Providing feedback on ABB Drives manuals

Your comments on our manuals are welcome. Go to www.abb.com/drives and select *Document Library – Manuals feedback form (LV AC drives)*.

Document library on the Internet

You can find manuals and other product documents in PDF format on the Internet. Go to www.abb.com/drives and select *Document Library*. You can browse the library or enter selection criteria, for example a document code, in the search field.



ABB Oy
AC Drives
P.O. Box 184
FI-00381 HELSINKI
FINLAND
Telephone +358 10 22 11
Fax +358 10 22 22681
Internet www.abb.com

ABB Inc.
Automation Technologies
Drives & Motors
16250 West Glendale Drive
New Berlin, WI 53151 USA
Telephone 262 785-3200
800-HELP-365
Fax 262 780-5135

ABB Beijing Drive Systems Co. Ltd.
No. 1, Block D, A-10 Jiuxianqiao Beilu
Chaoyang District
Beijing, P.R. China, 100015
Telephone +86 10 5821 7788
Fax +86 10 5821 7618
Internet www.abb.com

3AUA0000086933 Rev A / EN
EFFECTIVE: 03/01/2011



3AUA0000086933A