

JAZZY1107



OWNER'S MANUAL

Pride
Mobility Products Ltd.
www.pridemobility.com

32 Wedgwood Road • Bicester, Oxon OX26 4UL

SAFETY GUIDELINES



WARNING! An authorised Pride Dealer or a qualified technician must perform the initial setup of this power chair and must perform all of the procedures in this manual.

The symbols below are used throughout this owner's manual and on the power chair to identify warnings and important information. It is very important for you to read them and understand them completely.



WARNING! Indicates a potentially hazardous condition/situation. Failure to follow designated procedures can cause either personal injury, component damage or malfunction. On the product, this icon is represented as a black symbol on a yellow triangle with a black border.



MANDATORY! These actions should be performed as specified. Failure to perform mandatory actions can cause personal injury and/or equipment damage. On the product, this icon is represented as a white symbol on a blue dot with a white border.



PROHIBITED! These actions are prohibited. These actions should not be performed at any time or in any circumstances. Performing a prohibited action can cause personal injury and/or equipment damage. On the product, this icon is represented as a black symbol with a red circle and red slash.

Quick Reference Information

Authorised Pride Dealer: _____

Address: _____

Phone Number: _____

Purchase Date: _____

NOTE: This owner's manual is compiled from the latest specifications and product information available at the time of publication. We reserve the right to make changes as they become necessary. Any changes to our products may cause slight variations between the illustrations and explanations in this manual and the product you have purchased. The latest/current version of this manual is available on our website.

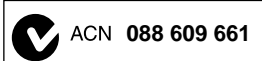

Copyright © 2007
Pride Mobility Products Ltd.

INFMANU2846/Rev B/November 2007

C O N T E N T S

I. INTRODUCTION.....	4
II. SAFETY	5
III. YOUR POWER CHAIR	17
IV. ASSEMBLY/DISASSEMBLY	21
V. COMFORT ADJUSTMENTS.....	25
VI. BATTERIES AND CHARGING	31
VII. CARE AND MAINTENANCE	35
VIII. WARRANTY	40
APPENDIX I - SPECIFICATIONS	41

I . I N T R O D U C T I O N

SAFETY

WELCOME to Pride Mobility Products Corporation (Pride). The power chair you have purchased combines state-of-the-art components with **safety**, comfort and styling in mind. We are confident that these design features will provide you with the conveniences you expect during your daily activities. Once you understand how to **safely** operate and care for your power chair, it should give you years of trouble free operation and service.

Read and follow all instructions, warnings and notes in this manual before attempting to operate your power chair for the first time. You must also read all instructions, warnings and notes contained in any supplemental instructional booklets for the controller, front riggings and/or seating system that accompanied your power chair before initial operation. Your **safety** depends upon you, as well as your provider, caretaker or healthcare professional in using good judgement.

If there is any information in this manual which you do not understand, or if you require additional assistance for setup or operation, please contact your authorised Pride Dealer. **Failure to follow the instructions in this manual and those located on your power chair can lead to personal injury and/or damage to the power chair, and may void the warranty.**

PURCHASER'S AGREEMENT

By accepting delivery of this product, you promise that you will not change, alter or modify this product or remove or render inoperable or unsafe any guards, shields or other safety features of this product; fail, refuse or neglect to install any retrofit kits from time to time provided by Pride to enhance or preserve the safe use of this product.

SHIPPING AND DELIVERY

Before using your power chair, make sure your delivery is complete as some components may be individually packaged. If you do not receive a complete delivery, please contact your authorised Pride Dealer immediately. Where damage has occurred during transport, either to the packaging or content, please contact the delivery company responsible.

INFORMATION EXCHANGE

We want to hear your questions, comments and suggestions about this manual. We would also like to hear about the safety and reliability of your new power chair, and about the service you received from your authorised Pride Dealer.

Please notify us of any change of address, so we can keep you apprised of important information about safety, new products and new options that can increase your ability to use and enjoy your power chair. Please feel free to contact us at the address below:

Pride Mobility Products Ltd.
32 Wedgwood Road
Bicester, Oxon OX26 4UL

NOTE: If you ever lose or misplace your product registration card or your copy of this manual, contact us and we will be glad to send you a new one immediately.

II. SAFETY

PRODUCT SAFETY SYMBOLS

The symbols below are used on the power chair to identify warnings, mandatory actions and prohibited actions. It is very important for you to read and understand them completely.



Read and follow the information in the owner's manual.



Do not allow unsupervised children to play near the power chair while the batteries are charging.



Maximum seating weight.



Keep your hands away from the tyres when driving. Be aware that loose fitting clothing can become caught in drive tyres.



Use correct tie-down points for controller harness to prevent the harness from getting caught in the drive tyres, pinched in the seat frame or damaged when passing through doorways.



Do not use a cell phone, walkie/talkie, laptop or other radio transmitter while operating.



Avoid exposure to rain, snow, ice, salt or standing water whenever possible. Maintain and store in a clean and dry condition.

II. SAFETY



Removal of grounding prong can create electrical hazard. If necessary, properly install an approved 3-pronged adapter to an electrical outlet having 2-pronged plug access.



Do not remove anti-tip wheels.



Do not place your power chair in freewheel mode while on a decline.



Do not place your power chair in freewheel mode while on an incline.



Do not lift the mobility product while seated in it.



Do not lift the mobility product while seated in it.

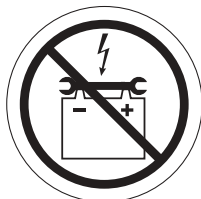

Keep tools and other metal objects away from battery terminals.



Wear safety goggles.

II. SAFETY



EMI-RFI - This product has been tested and passed at an immunity level of 20 V/m.



Explosive conditions exist!



Corrosive chemicals contained in battery.



Use only AGM or Gel-Cell batteries to reduce the risk of leakage or explosive conditions.

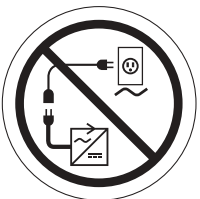

Do not connect an extension lead to the AC/DC converter or the battery charger.

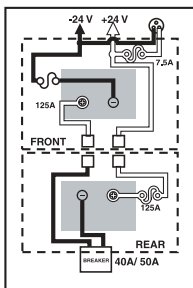

Battery Set Configuration:

+ = Positive (Red) Terminal Post

- = Negative (Black) Terminal Post

Connect Red wire to Red Positive (+) Terminal Post

Connect Black wire to Black Negative (-) Terminal Post



Do not use batteries with different amp-hour (Ah) capacities. Do not mix old and new batteries. Always replace both batteries at the same time.

II. SAFETY



Battery charger for indoor use only.



Disposal and recycling - Contact your authorised Pride Dealer for information on proper disposal and recycling of your Pride product and its packaging.



Locked and in drive mode.

Place unit on level ground and stand to one side when changing from drive mode to freewheel mode or freewheel mode to drive mode.

Unlocked and in freewheel mode.



Contains Lead.

II. SAFETY

SAFETY



MANDATORY! Do not operate your new power chair for the first time without completely reading and understanding this owner's manual.

Your power chair is a state-of-the-art life-enhancement device designed to increase mobility. Pride provides an extensive variety of products to best fit the individual needs of the power chair user. Please be aware that the final selection and purchasing decision regarding the type of power chair to be used is the responsibility of the power chair user, who is capable of making such a decision, and his/her healthcare professional (i.e., medical doctor, physical therapist, etc.).

The contents of this manual are based on the expectation that a mobility device expert has properly fitted the power chair to the user and has assisted the prescribing healthcare professional and/or the authorised Pride Dealer in the instruction process for the use of the product.

There are certain situations, including some medical conditions, where the power chair user will need to practice operating the power chair in the presence of a trained attendant. A trained attendant can be defined as a family member or care professional specially trained in assisting a power chair user in various daily living activities.

As you begin using your power chair during daily activities, you will probably encounter situations in which you will need some practice. Simply take your time and you will soon be in full and confident control as you manoeuvre through doorways, on and off of lifts, up and down ramps and over moderate terrain.

Below are some precautions, tips and other safety considerations that will help the user become accustomed to operating the power chair safely.

Modifications

Pride has designed and engineered your power chair to provide maximum mobility and utility. A wide range of accessories is available from your authorised Pride Dealer to further customise your power chair to better suit your needs and/or preferences. However, under no circumstances should you modify, add, remove or disable any feature, part or function of your power chair.



WARNING! Do not modify your power chair in any way not authorised by Pride. Do not use accessories if they have not been tested or approved for Pride products.

Pre-Ride Safety Check

Get to know the feel of your power chair and its capabilities. Pride recommends that you perform a safety check before each use to make sure your power chair operates smoothly and safely.

Perform the following inspections prior to using your power chair:

- Check for proper tyre inflation. Maintain but do not exceed **2.4 bar (35 psi)** in each tyre if equipped with pneumatic tyres.
- Check all electrical connections. Make sure they are tight and not corroded.
- Check all controller connections to the power base. Make sure they are secured properly.
- Check the brakes. See VII. "Care and Maintenance."
- Check battery charge. See VI. "Batteries and Charging."

NOTE: *If you discover a problem, contact your authorised Pride Dealer for assistance.*

II. SAFETY

Weight Limitations

Your power chair is rated for a maximum weight capacity. Please refer to the specifications table for this limit.



MANDATORY! Stay within the specified weight capacity of your power chair. Exceeding the weight capacity voids your warranty. Pride will not be held responsible for injuries and/or property damage resulting from failure to observe weight limitations.



WARNING! Do not carry passengers on your power chair. Carrying passengers on your power chair may affect the centre of gravity, resulting in a tip or a fall.

Tyre Inflation

If your power chair is equipped with pneumatic tyres, you should check or have the air pressure checked regularly. Proper inflation pressures will prolong the life of your tyres and help ensure the smooth operation of your power chair.



WARNING! It is important that 2.4 bar (35 psi) tyre pressure be maintained in pneumatic tyres at all times. Do not underinflate or overinflate your tyres. Low pressure may result in loss of control, and overinflated tyres may burst. Failure to maintain 2.4 bar (35 psi) tyre pressure in pneumatic tyres at all times may result in tyre and/or wheel failure.

WARNING! Inflate your power chair drive tyres from a regulated air source with an available pressure gauge. Inflating your tyres from an unregulated air source could overinflate them, resulting in a burst tyre.

Incline Information

More and more buildings have ramps with specified degrees of inclination, designed for easy and safe access. Some ramps may have turning switchbacks (180-degree turns) that require you to have good cornering skills on your power chair.

- Proceed with extreme caution as you approach the downgrade of a ramp or other incline.
- Take wide swings with your power chair's front wheels around any tight corners. If you do that, the power chair's rear wheels will follow a wide arc, not cut the corner short and not bump into or get hung up on any railing corners.
- When driving down a ramp, keep the power chair's speed adjustment set to the slowest speed setting to ensure a safely controlled descent.
- Avoid sudden stops and starts.

When climbing an incline, try to keep your power chair moving. If you must stop, start up again slowly and then accelerate cautiously. When driving down an incline, set your power chair to the slowest speed setting and drive in the forward direction only. If your power chair starts to move down the incline faster than you anticipated or desired, allow it to come to a complete stop by releasing the joystick, then push the joystick forward slightly to ensure a safely controlled descent.



WARNING! When on any sort of an incline or decline, never place the power chair in freewheel mode while seated on it or standing next to it.

WARNING! When climbing an incline, do not zigzag or drive at an angle up the face of the incline. Drive your power chair straight up the incline. This greatly reduces the possibility of a tip or a fall. Always exercise extreme caution when negotiating an incline.

WARNING! You should not travel up or down a potentially hazardous incline (i.e., areas covered with snow, ice, cut grass or wet leaves).



WARNING! Never travel down an incline rearward. Doing so may cause the power chair to tip. Always exercise extreme caution when negotiating an incline.

WARNING! If your power chair is equipped with a reclining seatback, do not attempt to negotiate inclines with the seat in a reclined position. Do not attempt to negotiate obstacles with the seat in a reclined position unless an attendant is present to help stabilise the chair. Failure to heed could result in the power chair tipping over.

II. SAFETY



WARNING! Even though your power chair is capable of climbing slopes greater than those illustrated in figure 1, do not, under any circumstances, exceed the incline guidelines or any other specifications presented in this manual. Doing so could cause instability in your power chair.

Pride recommends that the maximum slope of an incline you attempt to safely ascend or descend on your power chair does not exceed 8.7% (5°). See figure 1.



WARNING! Any attempt to climb or descend a slope steeper than 8.7% (5°) may put your power chair in an unstable position and cause it to tip.

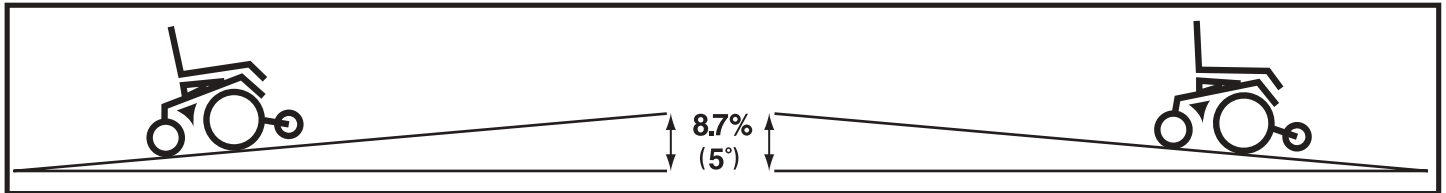

Figure 1. Maximum Safe Slope (Ascending and Descending)

Freewheel Mode

Your power chair is equipped with two manual freewheel levers to allow for manual manoeuvrability by a trained attendant. For more information about how to place your power chair into and out of freewheel mode, see III. “Your Power Chair.”



WARNING! Do not use your power chair in freewheel mode without an attendant present.

WARNING! Do not attempt to personally place your power chair in freewheel mode while seated on it. Ask an attendant for assistance if necessary.



WARNING! Do not place your power chair in freewheel mode while on an incline or decline. This could cause the chair to roll uncontrollably on its own.

Braking Information

Your power chair is equipped with two powerful brake systems:

- Regenerative — uses electricity to rapidly slow the vehicle when the joystick returns to the centre/stop position.
- Disc Park Brake — activates mechanically after regenerative braking slows the vehicle to near stop, or when power is removed from the system for any reason.

Cornering Information

While your power chair is equipped with front anti-tip wheels and rear castor wheels, excessively high cornering speeds can still create the possibility of tipping. Factors which affect the possibility of tipping include, but are not limited to: cornering speed, steering angle (how sharply you are turning), uneven road surfaces, inclined road surfaces, riding from an area of low traction to an area of high traction (such as passing from a grassy area to a paved area – especially at high speed while turning) and abrupt directional changes. High cornering speeds are not recommended. If you feel that you may tip over in a corner, reduce your speed and steering angle (i.e., lessen the sharpness of the turn) to prevent your power chair from tipping.



WARNING! When cornering sharply, reduce your speed and maintain a stable centre of gravity. This greatly reduces the possibility of a tip or fall. Always exercise common sense when cornering.

II. SAFETY

Public Streets and Roadways



WARNING! You should not operate your power chair on public streets and roadways. Be aware that it may be difficult for traffic to see you when you are seated on your power chair. Obey all local pedestrian traffic rules. Wait until your path is clear of traffic, and then proceed with extreme caution.

Outdoor Driving Surfaces

Your power chair is designed to provide optimum stability under normal driving conditions—dry, level surfaces composed of concrete, blacktop or tarmac. However, Pride recognises that there will be times when you will encounter other surface types. For this reason, your power chair is designed to perform admirably on packed soil, grass and gravel. Feel free to use your power chair safely on lawns and in park areas.

- Reduce your power chair's speed when driving on uneven terrain and/or soft surfaces.
- Avoid tall grass that can entangle the running gear.
- Avoid loosely packed gravel and sand.
- If you feel unsure about a driving surface, avoid that surface.

Inclement Weather Precautions

Exposure of your power chair to inclement weather conditions should be avoided whenever possible. If suddenly caught up in rain, snow, severe cold or heat while operating your power chair, proceed to shelter at the earliest opportunity. Thoroughly dry your power chair before storing, charging or operating your power chair.



PROHIBITED! Operating in rain, snow, salt, mist/spray conditions and on icy/slippery surfaces can have an adverse affect on the electrical system. Maintain and store your power chair in a dry and clean condition.



WARNING! Prolonged exposure to hot or cold conditions may affect the temperature of upholstered and non-upholstered items on the power chair, possibly resulting in skin irritation. Exercise caution when using the power chair in extremely hot or cold conditions or when exposing your power chair to direct sunlight for prolonged periods of time.

Stationary Obstacles (Steps, Kerbs, etc.)

Proceed with extreme caution when driving near raised surfaces, unprotected ledges and/or drop-offs (kerbs, porches, stairs, etc.). Be sure your power chair is traveling perpendicular to any kerb you may be required to navigate. See figure 2.



WARNING! Do not attempt to have your power chair climb or descend an obstacle that is higher than 5 cm (2 in.) unless you have the assistance of an attendant.

WARNING! Do not attempt to have your power chair proceed rearward down any step, kerb or other obstacle. This may cause the power chair to tip.

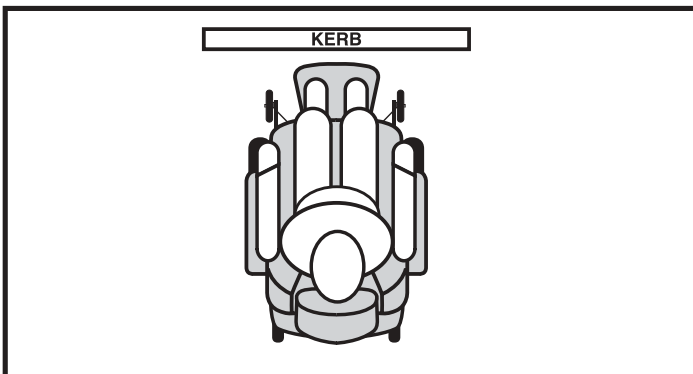

Figure 2. Correct Kerb Approach

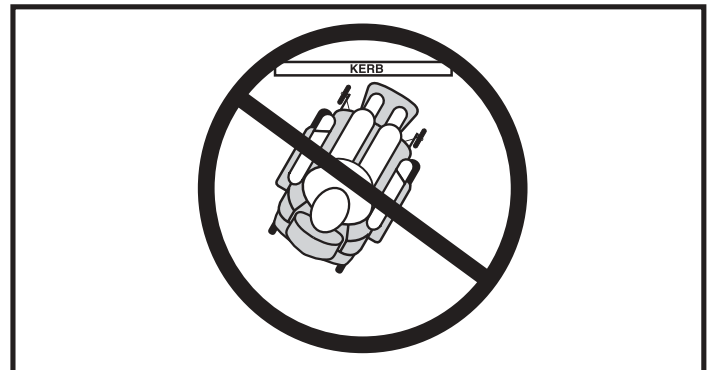

Figure 3. Incorrect Kerb Approach

II. SAFETY

Stairs and Escalators

Power chairs are not designed to travel up or down stairs or escalators. Always use a lift.



WARNING! Never use your power chair to negotiate steps or escalators.

Doors

- Determine if the door opens toward or away from you.
- Drive your power chair gently and slowly forward to push the door open or drive your power chair gently and slowly rearward to pull the door open.

Lifts

Modern lifts have a door edge safety mechanism that, when pushed, reopens the lift door(s).

- If you are in the doorway of a lift when the door(s) begin to close, push on the rubber door edge or allow the rubber door edge to contact the power chair and the door will reopen.
- Use care that handbags, packages or power chair accessories do not become caught in lift doors.

Lift/Elevation Products

If you will be traveling with your power chair, you may find it necessary to use a lift/elevation product to aid in transportation. Pride recommends that you closely review the instructions, specifications and safety information set forth by the manufacturer of the lift/elevation product before using that product.



WARNING! Never sit on your power chair when it is being used in connection with any type of lift/elevation product. Your power chair was not designed with such use in mind and any damage or injury incurred from such use is not the responsibility of Pride.

Motor Vehicle Transport

Pride recommends that you do not remain seated in your power chair while traveling in a motor vehicle. The power chair should be stowed in the boot of a car or in the back of a truck or van with batteries removed and properly secured.

WARNING! Do not sit on your power chair while it is in a moving vehicle.



WARNING! Always be sure your power chair and its batteries are properly secured when it is being transported. Batteries should be secured in an upright position and protective caps should be installed on the battery terminals. Batteries should not be transported with any flammable or combustible items.

Positioning Belts

Your authorised Pride Dealer, therapist(s) and other healthcare professionals are responsible for determining your requirement for a positioning belt in order to operate your power chair safely. Typically, the positioning belt is not designed for use as a restraining device in a motor vehicle.

Positioning belts should be installed as detailed in this manual. See V. “Comfort Adjustments.” Once installed, the belt should be placed across the pelvis as determined by the user’s healthcare dealer. Anchor points of the positioning belts should be located so that a projected side-view angle of the pelvis is between 30°–75° of horizontal depending on the user’s weight, posture and seat cushion thickness.



WARNING! If you require a positioning belt to safely operate your power chair, make sure it is fastened securely in order to reduce the possibility of a fall from the power chair.

WARNING! The positioning belt is not designed for use as a seat belt in a motor vehicle.

II. SAFETY

Batteries

In addition to following the warnings below, be sure to comply with all other battery handling information. For more information about your power chair's batteries, see VI. "Batteries and Charging."



WARNING! Battery posts, terminals and related accessories contain lead and lead compounds. Wear goggles and gloves when handling batteries and wash hands after handling.

WARNING! Power chair batteries are heavy. See specifications table. If you are unable to lift that much weight, be sure to get help. Use proper lifting techniques and avoid lifting beyond your capacity.



WARNING! Always protect the batteries from freezing and never charge a frozen battery. Charging a frozen battery may result in damage to the battery.

WARNING! Connect your battery harnesses in the proper manner. RED (+) cables must be connected to positive (+) battery terminals/posts. BLACK (-) cables must be connected to negative (-) battery terminals/posts. Protective caps should be installed over all battery terminals. REPLACE cables immediately if damaged.

Removable Parts



WARNING! Do not attempt to lift or move a power chair by any of its removable parts, including the armrests, seat, foot riggings, controller and shrouds.

Preventing Unintended Movement



WARNING! If you anticipate being seated in a stationary position for an extended period of time, turn off the power. This will prevent unexpected motion from inadvertent joystick contact. This will also eliminate the possibility of unintended chair movement from electromagnetic (EM) sources.

Reaching and Bending

Never reach, lean or bend while driving your power chair. If it is absolutely necessary to reach, lean or bend while seated on your power chair, it is important to maintain a stable centre of gravity and keep the power chair from tipping. Pride recommends that the power chair user determine his/her personal limitations and practice bending and reaching in the presence of a qualified healthcare professional.



WARNING! Do not bend, lean or reach for objects if you have to pick them up from the floor by reaching down between your knees or if you have to reach over the back of the seat. Movements such as these may change your centre of gravity and the weight distribution of the power chair, possibly causing your power chair to tip.



WARNING! Keep your hands away from the tyres when driving. Be aware that loose fitting clothing can become caught in drive tyres.

II. SAFETY

Transfers

Transferring onto and off of your power chair requires a good sense of balance. Always have an attendant or healthcare professional present while learning to properly transfer yourself.

To eliminate the possibility of injury, Pride recommends that you or a trained attendant perform the following tasks before attempting a transfer:

- Turn off the power to the controller.
- Ensure your power chair is not in freewheel mode. See III. “Your Power Chair.”
- Turn the castor wheels toward the transfer destination to improve power chair stability during transfer.
- Make sure both armrests are flipped up or removed from your power chair.
- Flip up the foot platform or move the leg rests aside; this will help to keep your feet from getting caught on the foot rigging during the transfer.
- Reduce the distance between your power chair and the object you are transferring onto.

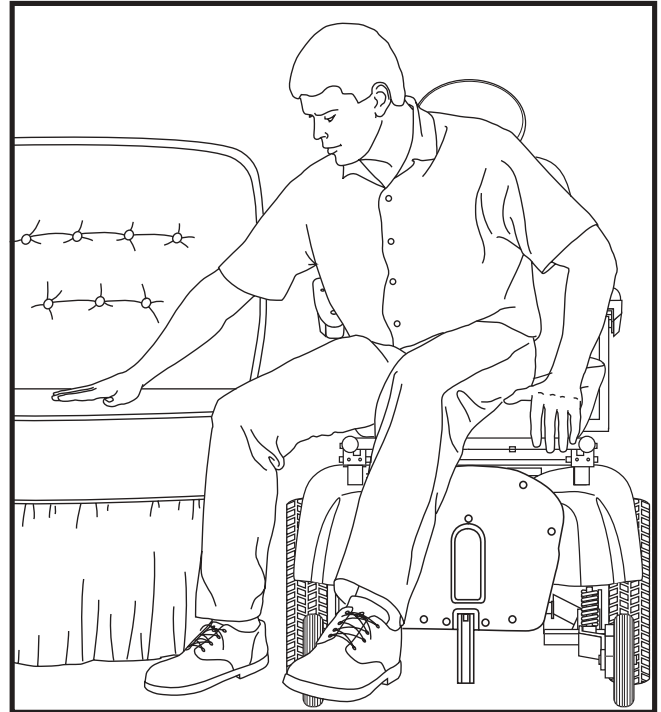

Figure 4. Ideal Transfer Position

WARNING! Before transferring, position yourself as far back as possible in the power chair seat to prevent the power chair from tipping forward during transfer.



WARNING! Avoid putting all of your weight on the power chair armrests and do not use the armrests for weight bearing purposes, such as transfers. Such use may cause the power chair to tip, resulting in a fall from the power chair and personal injury.

WARNING! Avoid putting all of your weight on the foot riggings. Such use may cause the power chair to tip.

User Positioning

Pride recommends that all users be seated in an upright position with their pelvis positioned as far rearward as possible in the power chair seat. All users need to discuss pelvic positioning with their authorised Pride Dealer, therapist(s) or healthcare professional to determine appropriate pelvic position when seated on the power chair based on the user's individual medical needs.

Prescription Drugs/Physical Limitations

Users must exercise care and common sense when operating a power chair. This includes awareness of safety issues when taking prescribed or over-the-counter drugs or when the user has specific physical limitations.



WARNING! Consult your physician if you are taking prescribed or over-the-counter medication or if you have certain physical limitations. Some medications and limitations may impair your ability to operate your power chair in a safe manner.

Alcohol/Smoking

The power chair user must exercise care and common sense when operating his/her power chair. This includes awareness of safety issues while under the influence of alcohol or while smoking.



WARNING! Do not operate your power chair while you are under the influence of alcohol, as this may impair your ability to operate your power chair in a safe manner.

II. SAFETY

WARNING! Pride strongly recommends that you do not smoke cigarettes while seated in your power chair, although the power chair has passed the necessary testing requirements for cigarette smoking. You must adhere to the following safety guidelines if you decide to smoke cigarettes while seated in your power chair.



- Do not leave lit cigarettes unattended.
- Keep ashtrays a safe distance from the seat cushions.
- Always make sure cigarettes are completely extinguished before disposal.

Electromagnetic and Radio Frequency Interference (EMI/RFI)



WARNING! Laboratory tests have shown that electromagnetic and radio frequency waves can have an adverse affect on the performance of electrically-powered mobility vehicles.

Electromagnetic and Radio Frequency Interference can come from sources such as cellular phones, mobile two-way radios (such as walkie-talkies), radio stations, TV stations, amateur radio (HAM) transmitters, wireless computer links, microwave signals, paging transmitters and medium-range mobile transceivers used by emergency vehicles. In some cases, these waves can cause unintended movement or damage to the control system. Every electrically-powered mobility vehicle has an immunity (or resistance) to EMI. The higher the immunity level, the greater the protection against EMI. This product has been tested and has passed at an immunity level of 20 V/m.



WARNING! Be aware that cell phones, two-way radios, laptops and other types of radio transmitters may cause unintended movement of your electrically-powered mobility vehicle due to EMI. Exercise caution when using any of these items while operating your mobility vehicle and avoid coming into close proximity of radio and TV stations.



WARNING! The addition of accessories or components to the electrically-powered mobility vehicle can increase the susceptibility of the vehicle to EMI. Do not modify your power chair in any way not authorised by Pride.

WARNING! The electrically-powered mobility vehicle itself can disturb the performance of other electrical devices located nearby, such as alarm systems.

NOTE: For further information on EMI/RFI, go to the Resource Center on www.pridemobility.com. If unintended motion or brake release occurs, turn your power chair off as soon as it is safe to do so. Contact your authorised Pride Dealer to report the incident.

III. YOUR POWER CHAIR

THE JAZZY 1107

The Jazzy has two main assemblies: the seat assembly and the power base assembly. See figure 5. Typically, the seat assembly includes the armrests, seatback and seat base. The power base assembly includes two motor/brake assemblies, two drive wheels, two anti-tip wheels, two castor wheels, two battery boxes and wiring harnesses. See figures 5, 6, and 7.

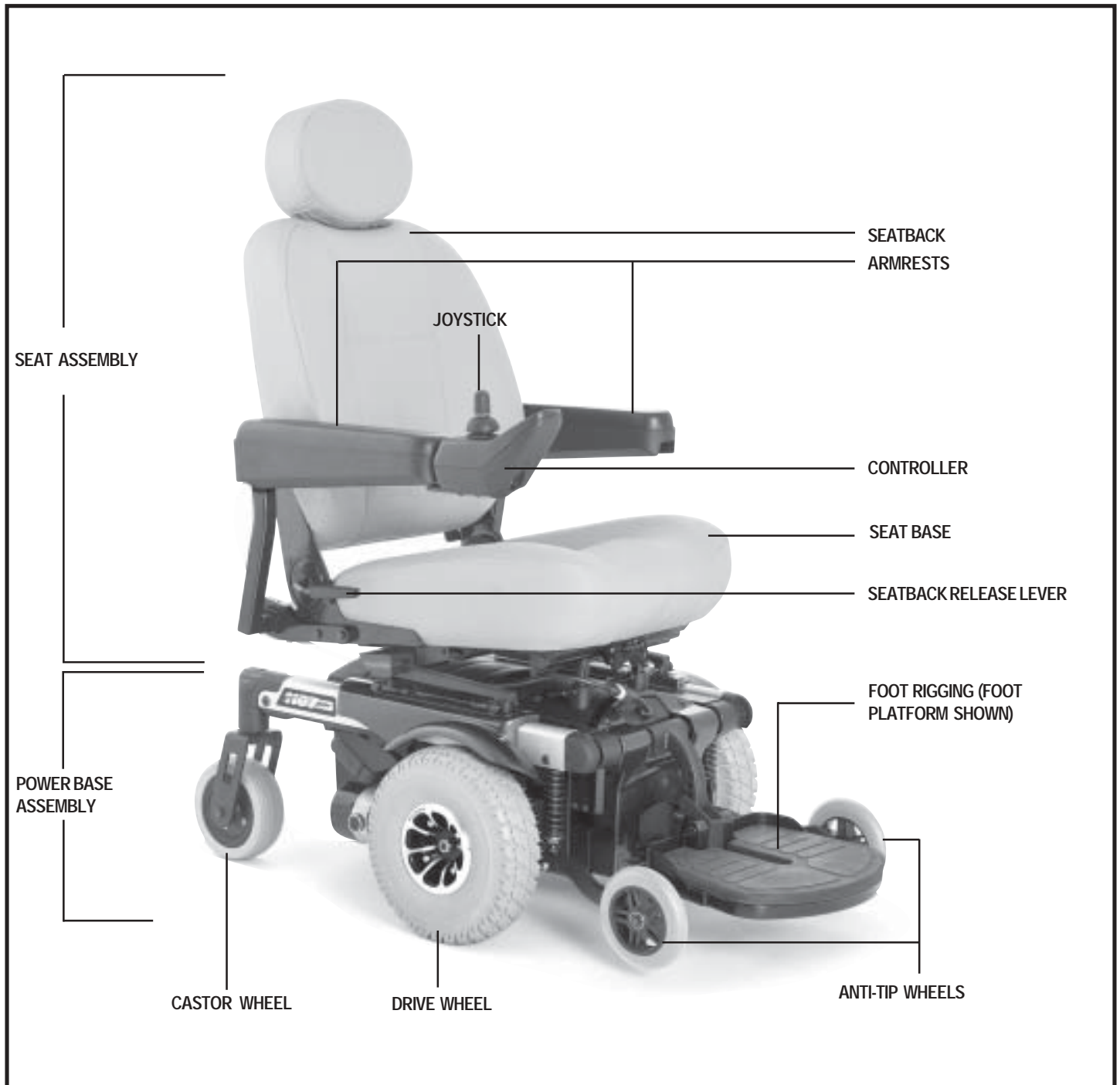

Figure 5. The Jazzy 1107

III. YOUR POWER CHAIR

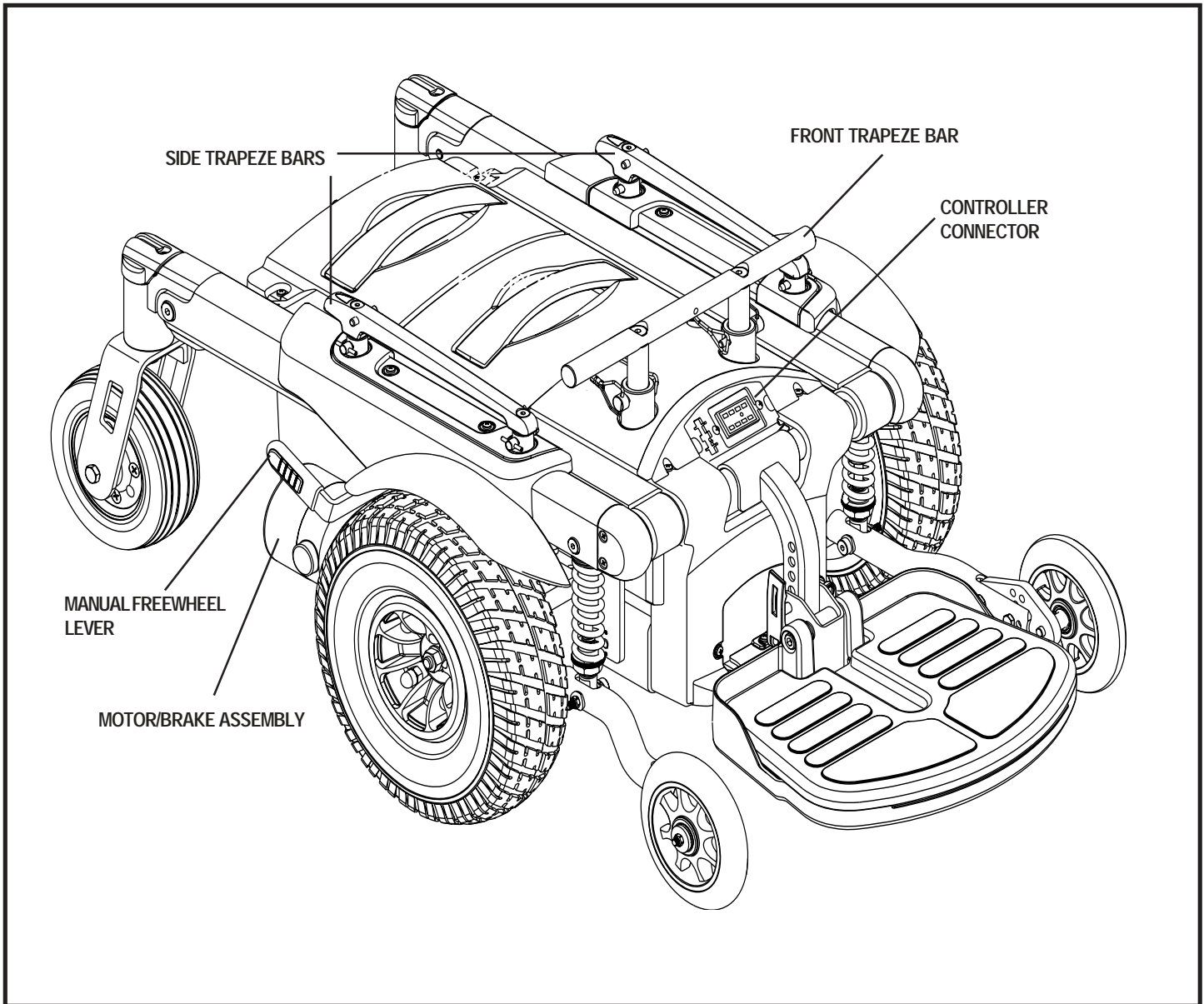

Figure 6. The Jazzy 1107 Power Base

Electrical Components

The electrical components consist of the controller assembly, the batteries and the motors. The batteries, motors and controller power module are located on the power base assembly. See figures 6 and 7. The controller is located on the seat assembly. Connectivity between the controller and the motors, the batteries and the battery charger is provided by one or more wiring harnesses.

Controller Harness Connector: The controller harness connector is where the controller plugs into the power base. Each controller uses a different type of harness. If the controller has a power module in the power base, the connector is a small communications-type connector. If the controller is integrated, then the harness has a large 9-pin connector. Regardless of which type of controller is used, the harness must be secured to the seat assembly and not allowed to drag on the floor.

Battery Harness Connector: This is where the controller connects to the battery boxes.

III. YOUR POWER CHAIR

Motor Connectors: This is where the motors connect to the controller power module.

Main Circuit Breaker (located on rear battery box): The main circuit breaker is a safety feature built into your power chair. When the batteries and the motors are heavily strained (e.g., from excessive loads), the main circuit breaker trips to prevent damage to the motors and the electronics. If the circuit trips, allow your power chair to “rest” for approximately one minute. Next, push in the circuit breaker button, turn on the controller, and continue normal operation. If the main circuit breaker continues to trip repeatedly, contact your authorised Pride Dealer.

Controller Power Module: The controller power module enables the controller to communicate with the batteries and the motors.

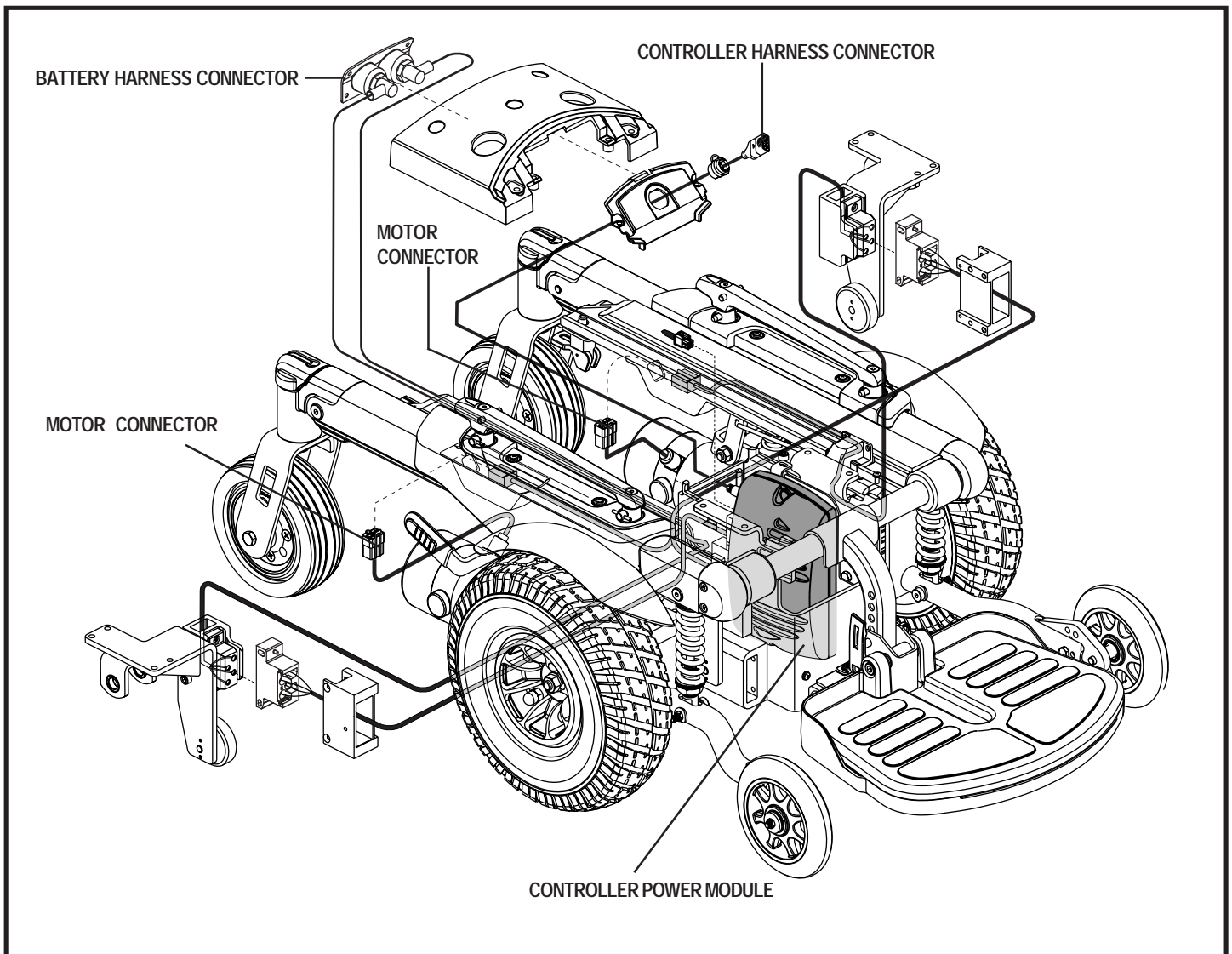

Figure 7. Jazzy 1107 Electrical Components (FLIGHT Controller Shown)

III. YOUR POWER CHAIR

Manual Freewheel Levers

Your power chair has a manual freewheel lever on each motor. See figure 6. Manual freewheel levers enable you to disengage the drive motors from the gearboxes and manoeuvre the chair manually.



WARNING! Do not use the power chair while the drive motors are disengaged! Do not disengage the drive motors when the power chair is on an incline or decline, as the unit could roll on its own. Only engage the freewheel mode when on a level surface.



WARNING! It is important to remember that when your power chair is in freewheel mode, the braking system is disengaged.

To engage or disengage the drive motors:

1. Locate the lever on top of each motor.
2. Pull the two levers upward to engage the drive motors (drive mode). See figure 8.
3. Push the two levers downward to disengage the drive motors (freewheel mode). See figure 9.

If a lever is difficult to move in either direction, slightly rock the power chair back and forth. The lever should then move to the desired position.



WARNING! Do not use freewheel lever handles as tie-down points to secure this product.

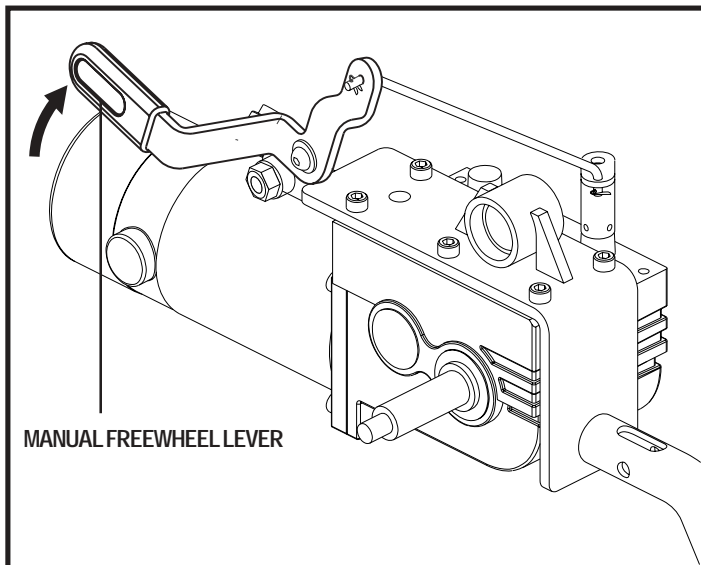

Figure 8. Drive Mode (Drive Engaged)

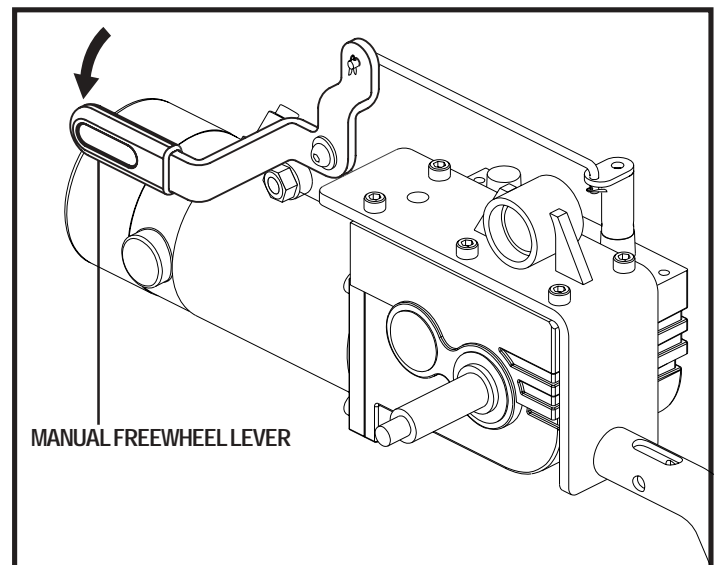

Figure 9. Freewheel Mode (Drive Disengaged)

IV. ASSEMBLY/DISASSEMBLY

INITIAL ASSEMBLY

Your power chair may require some assembly either before initial use or after transportation. It may also require disassembly to make some comfort adjustments. Figure 10 details those parts of the power chair that are designed to be disassembled and assembled by an end user or by a qualified carer before using the product or making comfort adjustments.

NOTE: Any nylon insert lock nut removed during the disassembly or adjustment of the power chair must be replaced with a new nut. Nylon insert lock nuts should not be reused as it may cause damage to the nylon insert, resulting in a less secure fit. Replacement nylon insert lock nuts are available at local hardware stores or through your authorised Pride Dealer.

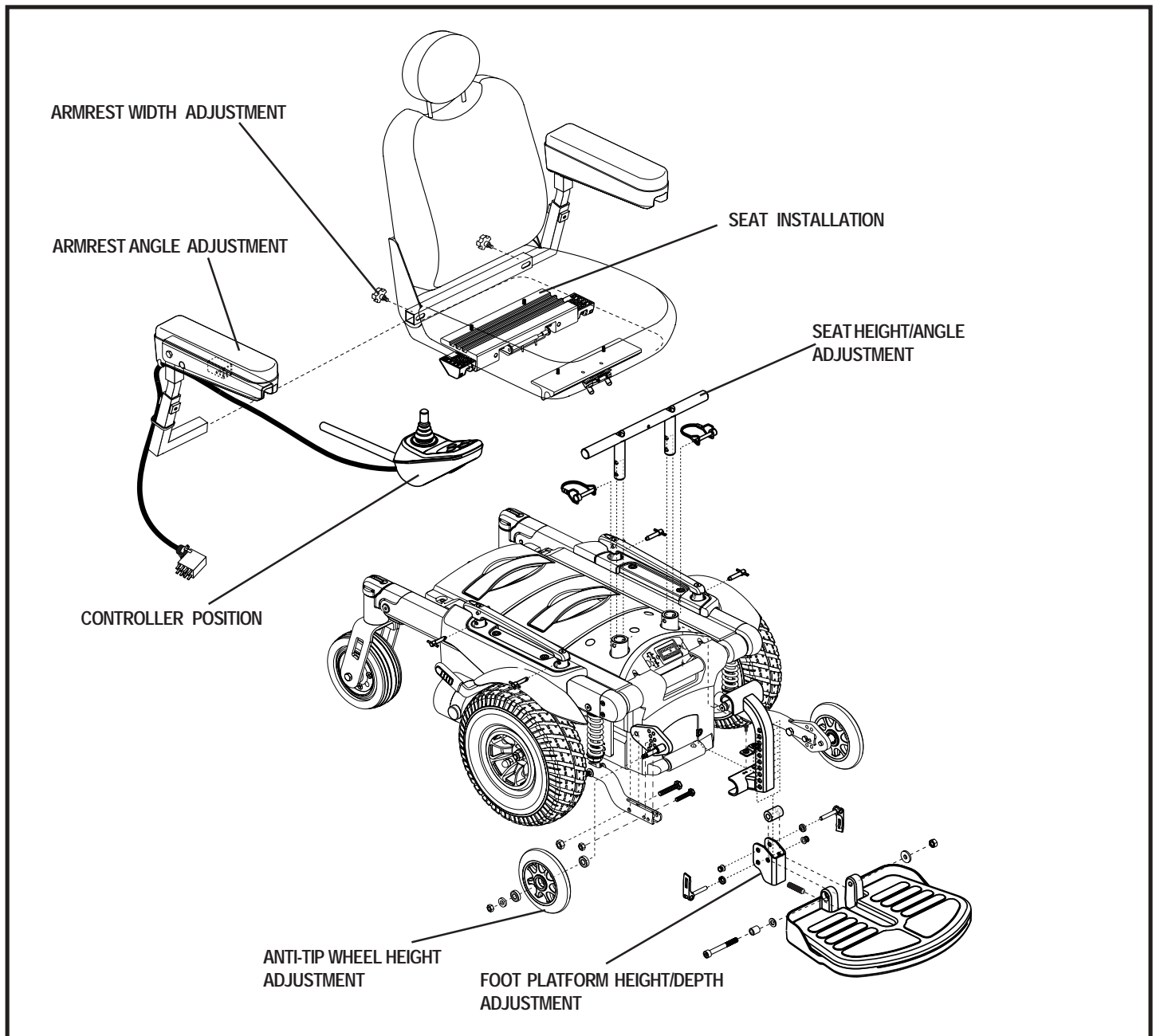

Figure 10. Jazzy 1107 Assembly View

Seat Installation

It may be necessary to install the seat either prior to initial operation or after transporting your power chair. Most seats are attached to the power base with the Universal Mounting System (UMS). The UMS consists of universal parts that may be attached to any medium-back or high-back seat, regardless of seat width or seat depth. The two main components are aluminum extrusions mounted to the seat base. These extrusions attach to a set of trapeze bars that are mounted to the power base (see figure 12).



WARNING! Do not pick up the seat frame by the armrests. They are free to pivot, and you may lose control of the seat if they do so.

To install the seat (initial installation):

1. Prior to initial installation, the rear seat interface needs to be installed to the seat base.
2. Slide the rear seat interface into the rear extrusion. See figure 11.
3. Squeeze the retaining pin and clip it onto the rear seat interface.
4. Slide the seat onto the side trapeze bars and slowly lower the seat onto the front trapeze bar until it locks into place. See figure 12.
5. Flip the seat latch safety down. See figure 12.



WARNING! Make sure the seat latch safety is flipped down before using your power chair.

6. Install the controller into one of the armrests. See figure 10.
7. Tighten the setscrew on the armrest. See figure 19.
8. Route the controller cable so that it cannot be pinched in the seat hinge.
9. Secure the controller cable to the armrest receiver with one or more wire ties.



MANDATORY! Prevent controller harness damage! Avoid routing the controller harness on the outside of the armrest pad. Route the harness under the armrest or toward the inside of the armrest pad. Use correct tie-down points for the controller harness to prevent the harness from getting caught in the drive tyres, pinched in the seat frame or damaged when passing through doorways.

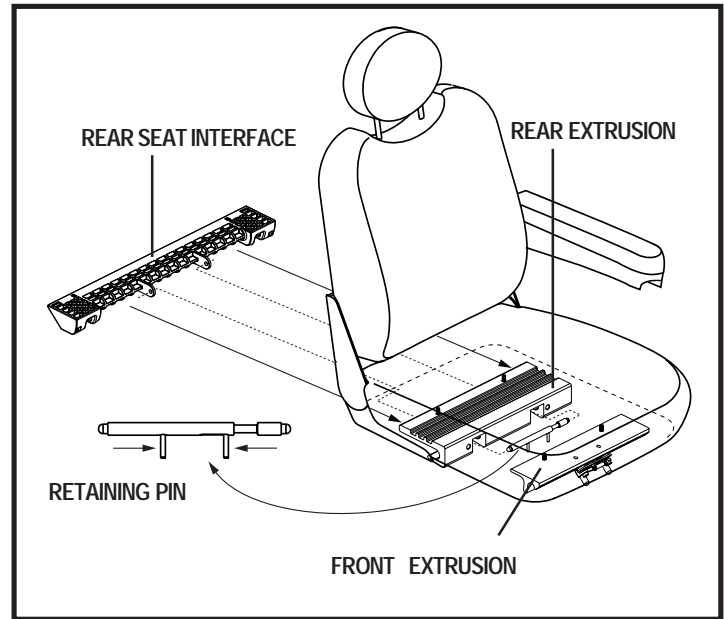

Figure 11. Assembly View (Rear Seat Interface Installation)

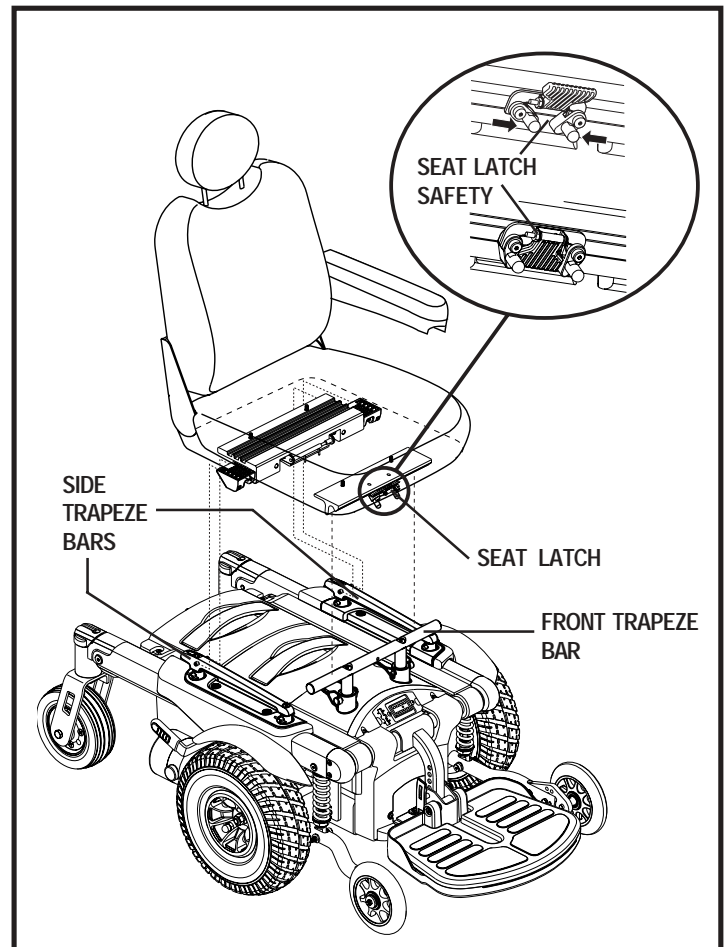

Figure 12. Seat Installation

IV. ASSEMBLY/DISASSEMBLY

To remove the seat:

1. Flip up the seat latch safety.
2. Squeeze the seat latch together. See figure 12.
3. Pull the front of the seat up.
4. Slide the seat forward and off of the power base.

Power Base Disassembly

The Jazzy 1107 power base disassembles into six parts for easy transportation and storage. See figure 13.

To disassemble the power base:

1. Turn off the power to the controller.
2. Disconnect the controller from the power base. See figure 6.
3. Remove the seat.
4. Press the foot platform release button and lift off the foot platform. See figure 13.
5. Flip down the battery box latches on each side of the power base. See figure 14.
6. Slide the battery boxes back and off of the power base.
7. Flip up the centre section latch. See figure 14.
8. Rotate the centre section forward.
9. Grab a side section by the side frame handle.
10. Lift the side section up and off of the centre section.
11. Grab the other side section by the side frame handle.
12. Lift the side section up and off of the centre section.

NOTE: Perform the disassembly steps in reverse order to assemble the power chair.

NOTE: During assembly, make sure the battery box latches are in the up (locked) position and the centre section latch is in the down (locked) position.

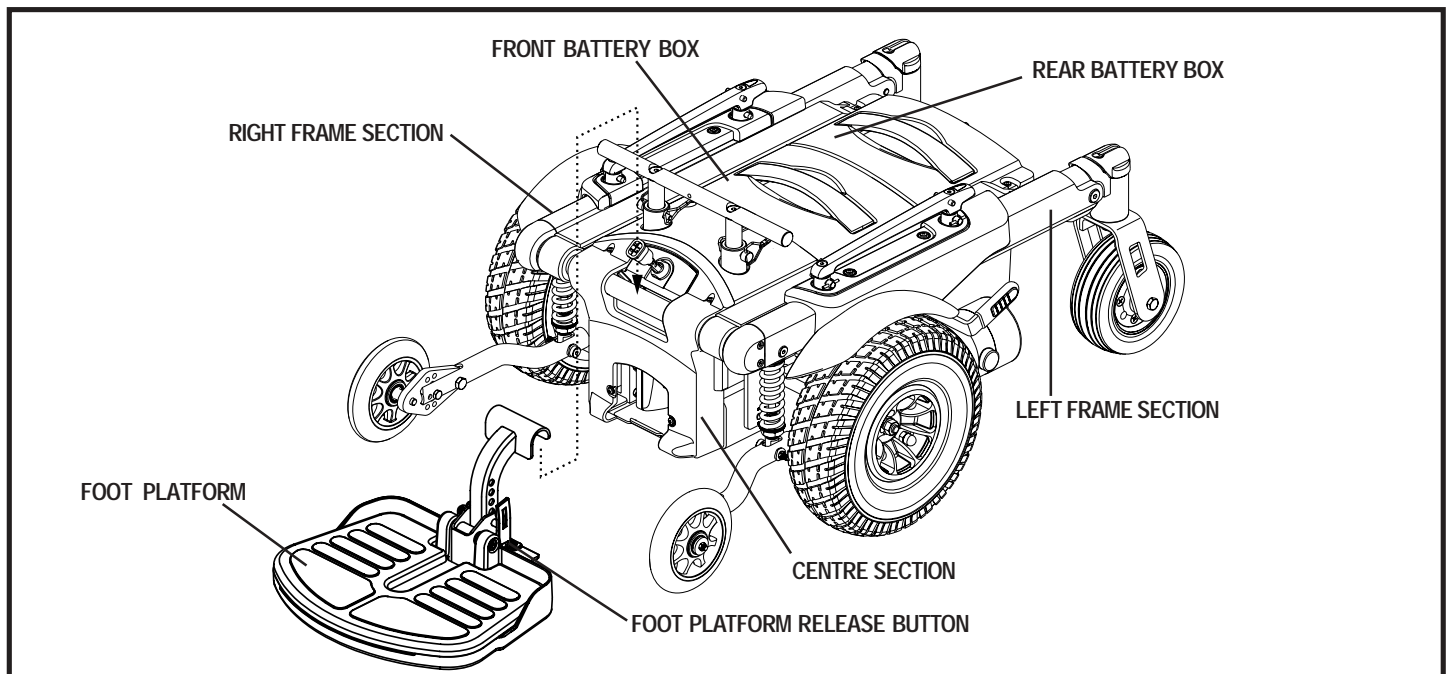

Figure 13. Power Base Components

IV. ASSEMBLY/DISASSEMBLY

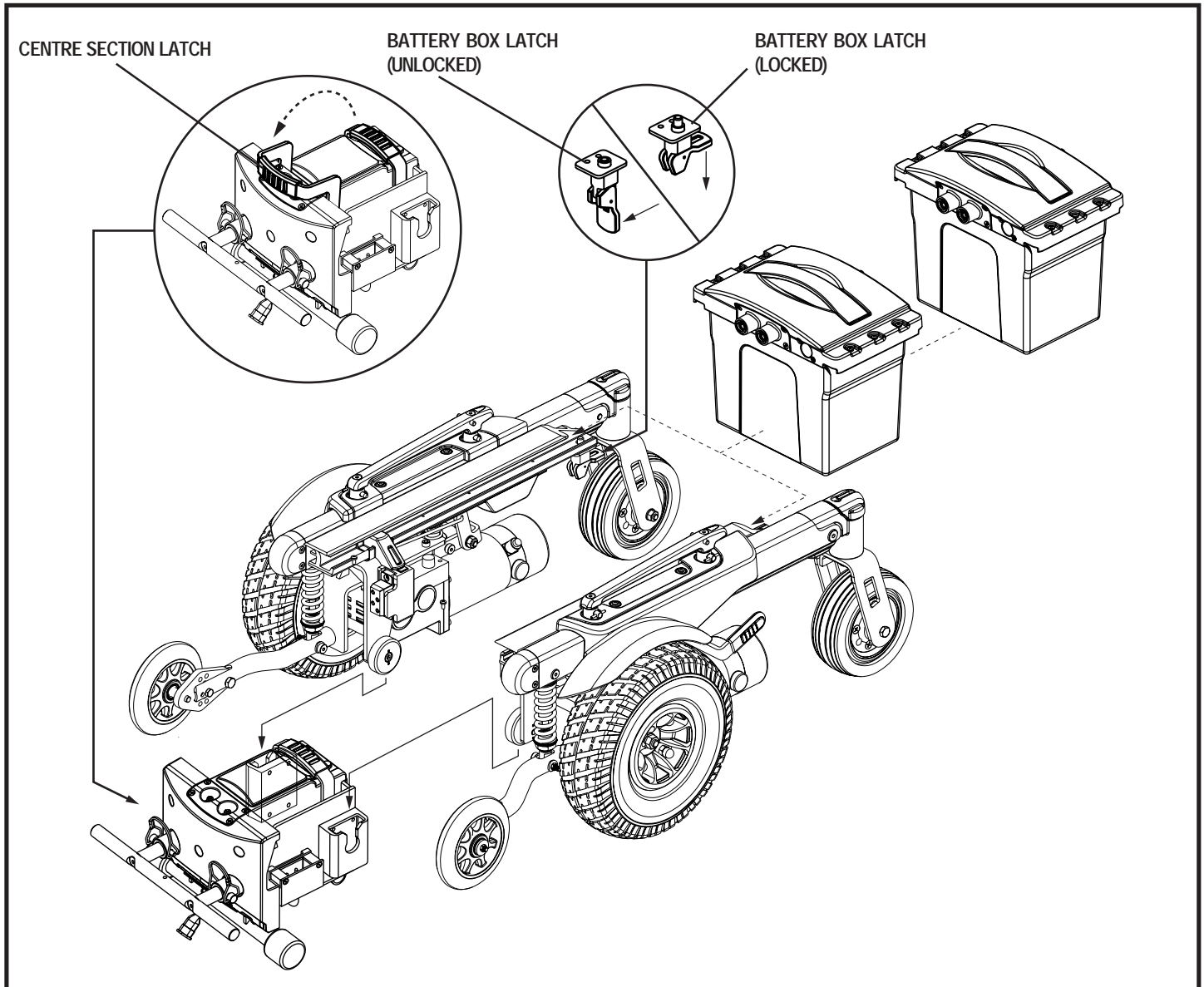

Figure 14. Battery Box Removal and Frame Separation

V. COMFORT ADJUSTMENTS

COMFORT ADJUSTMENTS

After becoming familiar with your power chair's operation, you may find the need to make some adjustments to increase your comfort. These adjustments include seat height and angle, armrest angle, foot platform height and angle and controller position.

NOTE: If your power chair is equipped with a Specialty Seat or a Synergy Seat, refer to the information provided in separate manuals. If your power chair is equipped with a contoured seat, refer to the following information.

WARNING! If your power chair was configured by your authorised Pride Dealer, please consult your healthcare professional before changing the seat position or making any other adjustment. Some adjustments may degrade your power chair's performance and safety by changing its centre of gravity.



WARNING! Some power chair components are heavy. You may need assistance to lift or carry them. Please refer to the specifications table for specific component weights before you disassemble the power chair.

WARNING! Remove the occupant from the power chair before making any adjustments.

You may need the following to make comfort adjustments:

- metric/standard socket set and ratchet
- adjustable spanner
- thread lock

Seat Height and Seat Angle Adjustment

You can change the seat height to one of two positions in 2.5 cm (1 in.) increments by raising the front seat interface and side frame handles. See figures 15 and 16. If you raise or lower only the front seat interface or the side frame handles, you can also change the seat base angle (dump).

To change the seat height:

1. Turn off the power to the controller.
2. Disconnect the controller from the power base. See figure 6.
3. Remove the seat from the power base.
4. Loosen the screws that attach the side frame handles and front seat interface to the seat posts. See figures 15 and 16.
5. Remove the retaining clips that secure the seat posts to the power base.
6. Move the seat posts up or down to the desired height.
7. Reinstall the retaining clips.
8. Remove each screw from the side frame handles and front seat interface and apply thread lock.
9. Reinstall each screw and tighten.
10. Reinstall the seat.
11. Reconnect the controller to the power base.

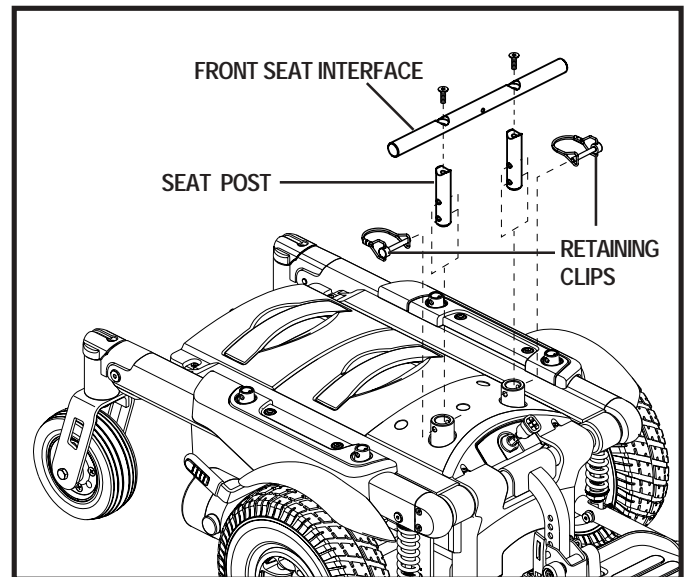

Figure 15. Front Seat Interface Height Adjustment

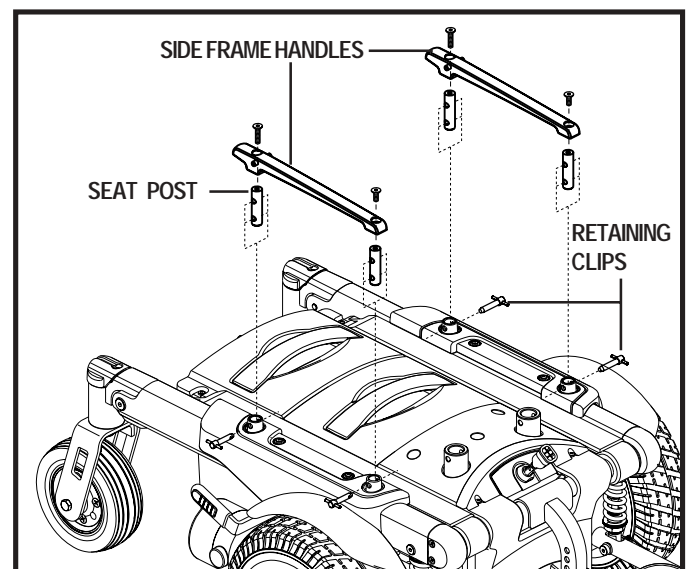

Figure 16. Side Frame Handles Height Adjustment

V. COMFORT ADJUSTMENTS

Seat Position Adjustment

You can move the seat forward or rearward by changing the extrusion mounting position.

To change the position:

1. Turn off the power to the controller.
2. Unplug the controller from the power base.
3. Remove the seat from the power base.
4. Remove both extrusions from the bottom of the seat. See figure 17.
5. Reposition the extrusions on a different set of mounting holes. You must move both extrusions the same number of holes either forward or rearward. See figure 17.
6. Fasten the extrusions back onto the bottom of the seat.
7. Reinstall the seat.
8. Plug the controller into the power base.

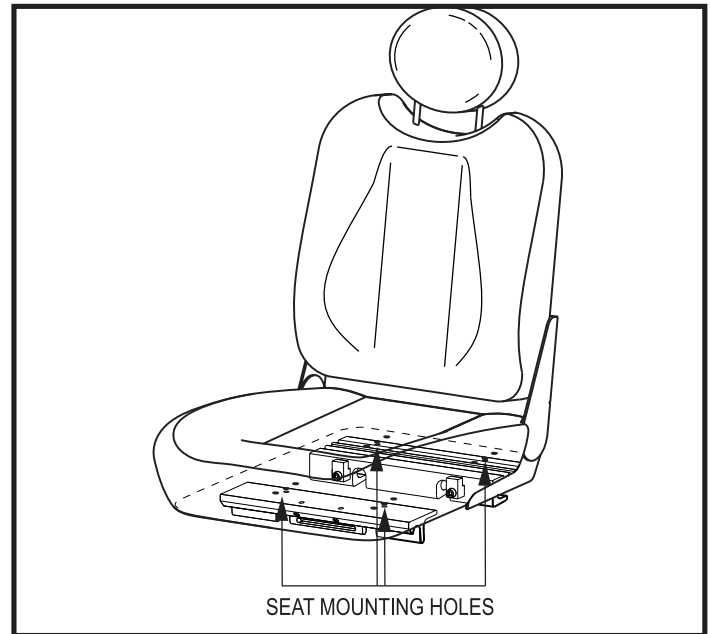

Figure 17. Seat Position Adjustment

Manual Recline Seatback Adjustment

If your power chair is equipped with a reclining seat, you can adjust the seatback angle with the seatback release lever. The lever is located on the right side of the seat base. See figure 5.

To adjust the recline angle:

1. Pull up on the seatback release lever.
2. Lean forward or rearward to the desired position.
3. Release the lever.

Seatback Angle Adjustment

If your power chair is equipped with an adjustable seatback, you can adjust it to four (4) different angles: 90°, 102°, 105° or 107°.

To adjust the seatback angle:

1. Remove the seatback angle adjusting screw from each seat hinge. See figure 18.
2. Set the seatback at the desired angle.
3. Reinstall the seatback angle adjusting screw to each seat hinge and tighten.

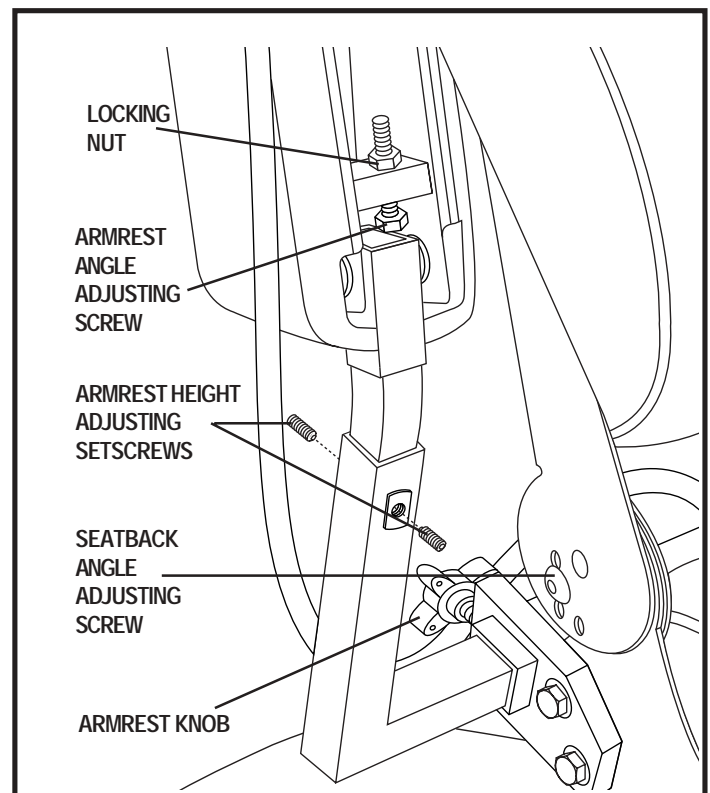

Figure 18. Seatback Angle Adjustment

V. COMFORT ADJUSTMENTS

Armrest Width Adjustment

You can change each armrest's width independently of the other.

NOTE: *Changing the armrest width may increase the overall width of your power chair.*

To change the armrest width:

1. Locate the armrest knob on each side of the armrest receiver bracket. See figure 18.
2. Loosen the knobs.
3. Slide the armrests in or out to the desired width.
4. Tighten the knobs.

Armrest Angle Adjustment

To change the armrest angle:

1. Lift the armrest straight up so that it is perpendicular to the floor. See figure 18.
2. Loosen the locking nut.
3. Turn adjusting screw to raise or lower the front of the armrest.
4. Tighten the locking nut to lock the armrest angle adjusting screw into place.

Controller Position

You can position the controller for either left-hand or right-hand use.



WARNING! Do not place the controller harness so that it can be pinched in the seat frame or the power base frame.

To extend the controller:

1. Flip up the armrest so it is perpendicular to the floor.
2. Loosen the setscrew on the controller bracket. See figure 19.
3. Slide the controller into or out of the armrest to the desired position.
4. Tighten the setscrew to secure the controller.

To change the controller position:

1. Turn off the power to the controller.
2. Disconnect the controller from the power base.
3. Cut the wire tie(s) that attaches the controller cable to the armrest.
4. Flip up the armrest and loosen the setscrew. See figure 19.
5. Slide the controller out of the armrest.
6. Loosen the setscrew in the other armrest.
7. Place the controller in the other armrest.
8. Tighten the setscrew to secure the controller.
9. Use a wire tie to secure the controller cable to the armrest.
10. Plug the controller into the power base. See figure 6.

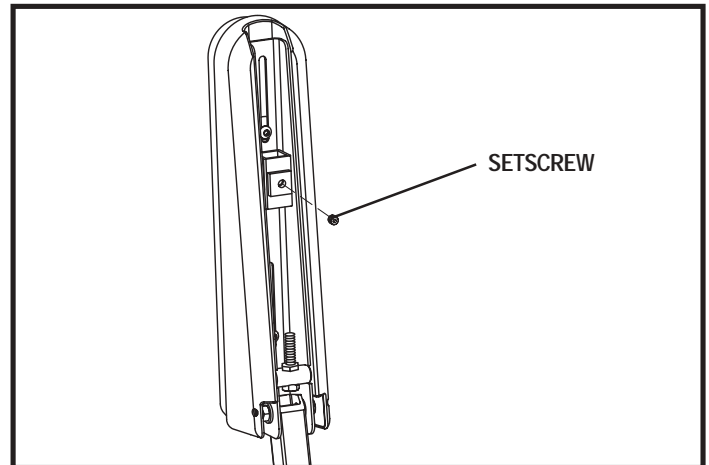

Figure 19. Underside of Armrest

Foot Platform Height Adjustment

The foot platform height is easily adjusted to different heights in 1.27 cm. (0.50 in.) increments.

To raise or lower the foot platform:

1. Remove the quick release fasteners from the foot platform bracket. See figure 20.
2. Raise or lower the foot platform to the desired height.
3. Reinstall the quick release fasteners into the foot platform bracket and tighten.

Foot Platform Depth Adjustment

To adjust the foot platform depth:

1. Remove the quick release fasteners from the foot platform bracket. See figure 20.
2. Move the foot platform in or out to the desired depth.
3. Reinstall the quick release fasteners into the foot platform bracket and tighten.

Quick Release Fasteners

The foot platform is attached to the power base with two quick release fasteners. See figure 20. Each quick release fastener consists of a bolt, a lever and a nut. See figure 21. The lever has a cam on the end that allows it to clamp into place. The quick release fastener has two states: clamped and unclamped. When the lever is open, the quick release fastener is unclamped. When the lever is closed, the quick release fastener is clamped.

To clamp the quick release fastener:

1. Make sure the lever is in the open position.
2. Turn the nut clockwise until it is snug.
3. Rotate the lever until it is in the fully closed position.

NOTE: If the lever will not rotate to the fully closed position, then turn the nut anticlockwise one-quarter or one-half turn.

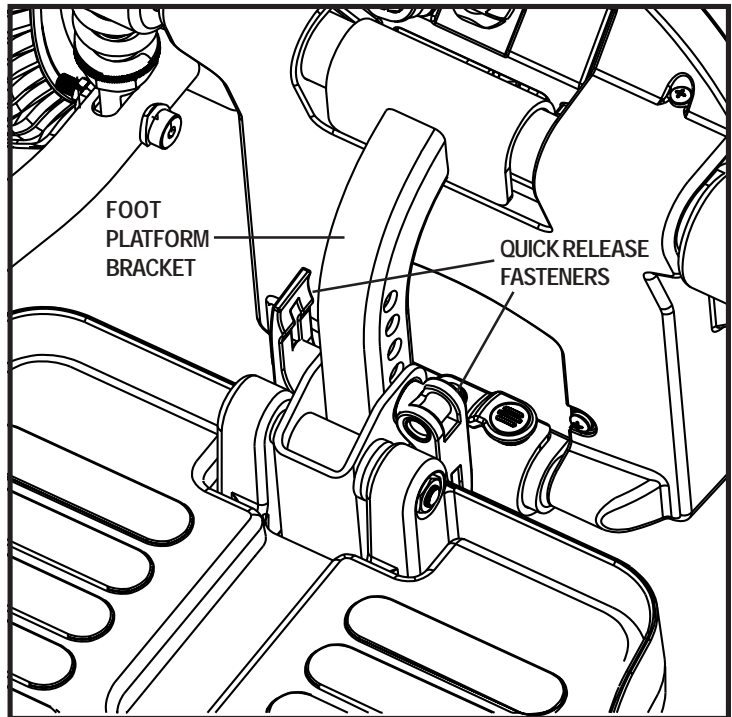

Figure 20. Foot Platform Adjustment

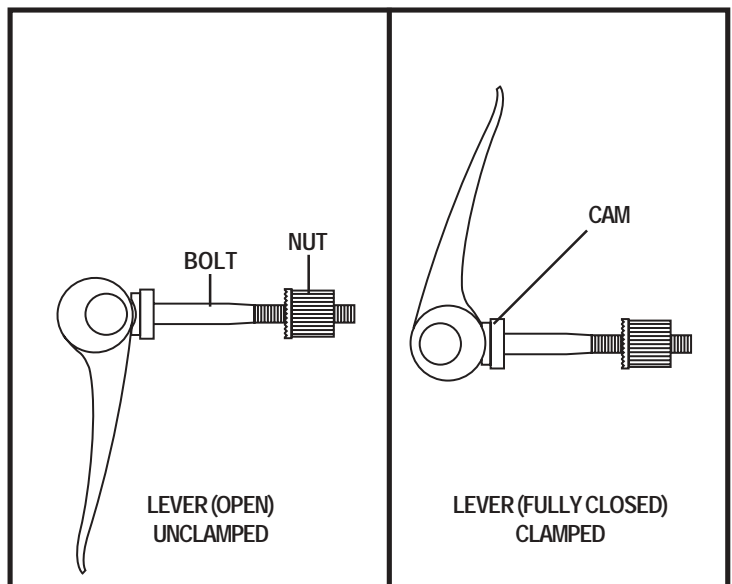

Figure 21. Quick Release Fastener Operation

Foot Platform Angle Adjustment

You can adjust the angle of the foot platform with a hex key. See figure 22.

To adjust the foot platform angle:

1. Locate the setscrew on the underside of the foot platform
2. Turn the setscrew anticlockwise to raise or lower the front of the foot platform.

Anti-Tip Wheels

The anti-tip wheels are designed to give your power chair increased stability on rough surfaces. The anti-tip wheels are preset at the factory for smooth surfaces or indoor use only. If you plan on using your power chair on rough surfaces, it may be necessary to adjust the anti-tip wheels to better suit your needs. The anti-tip wheels may need adjustment if the following occurs:

- When coming to a stop, your power chair tips forward excessively.
- The anti-tip wheels constantly rub the ground.

WARNING! Consult your authorised Pride Dealer before attempting to change the anti-tip wheel height! Changing the anti-tip wheel height affects handling under acceleration!



WARNING! The higher you raise the anti-tip wheels, the more you increase your power chair's tendency to tilt forward while decelerating. You can compensate for this by having your authorised Pride Dealer make a small adjustment to the pre-programmed deceleration setting in the controller or by moving the seat assembly farther to the back of your power chair.



PROHIBITED! Do not remove the anti-tip wheels.

NOTE: Each drive tyre must be inflated to 2.4 bar (35 psi) if equipped with pneumatic tyres. The user must also be seated in the power chair in order to properly adjust the anti-tip wheels.

To adjust the anti-tip wheels:

1. Loosen nut A. See figure 23.
2. Remove bolt B.
3. Raise or lower the anti-tip wheel. Each hole is 1.27 cm (0.50 in.) apart.
4. Reinstall bolt B.
5. Tighten nut A.
6. Raise or lower the other anti-tip wheel so that it is at the same height.

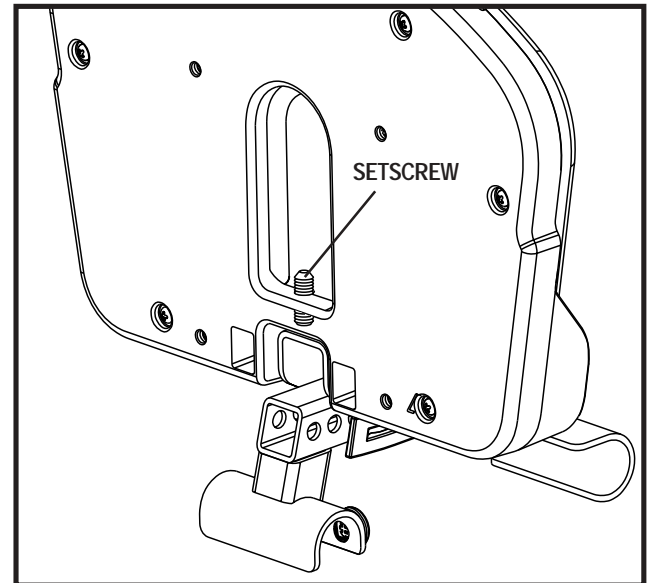

Figure 22. Underside of Foot Platform

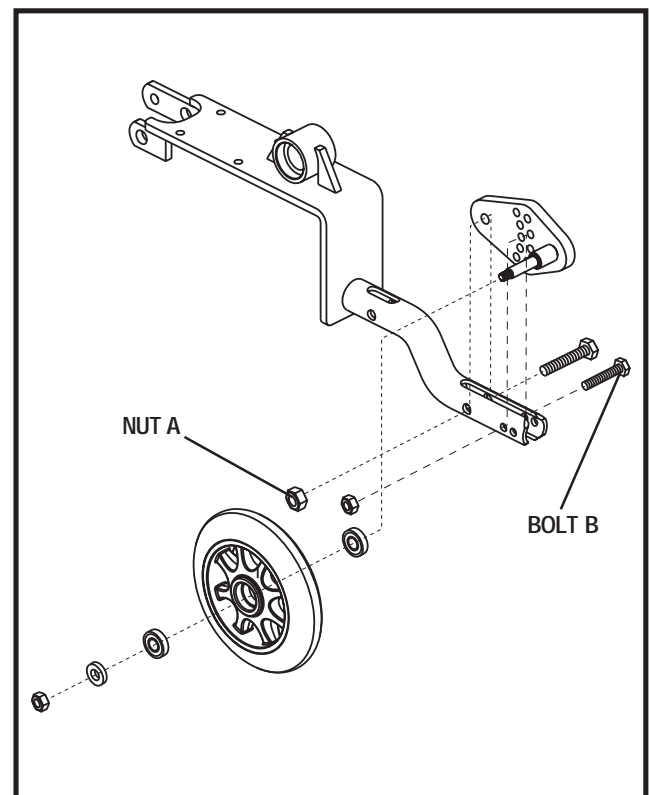

Figure 23. Anti-Tip Wheel Assembly

V. COMFORT ADJUSTMENTS

Positioning Belt

Your power chair may be equipped with a positioning belt that can be adjusted for operator comfort. See figure 24. The positioning belt is designed to support the operator so that he/she does not slide down or forward in the seat. The positioning belt is not designed for use as a restraining device.

To install the positioning belt:

1. Remove the rearmost screw that holds the seat hinge to the seat base on both the left and right seat hinges.
2. Insert the screw through the supplied washer, through the positioning belt and into the seat base for each side of the power chair seat.
3. Tighten both screws.

To adjust the positioning belt for operator comfort:

1. Once seated, insert the metal tab on one side of the belt into the plastic housing on the opposite side until you hear a click. See figure 24.
2. Pull the excess strap attached to the metal tab until it is secure, but not so tight as to cause discomfort.

To release the positioning belt:

1. Press the push button mechanism on the plastic housing.

MANDATORY! Make sure the positioning belt is properly secured to the power chair and is adjusted for operator comfort before each use.



MANDATORY! Inspect the positioning belt for loose or damaged parts before each use of the power chair. If you discover a problem, contact your authorised Pride Dealer for maintenance and repair.



Figure 24. Positioning Belt Adjustment

VI. BATTERIES AND CHARGING

BATTERIES AND CHARGING

Your Jazzy 1107 uses two long-lasting, 12-volt, deep-cycle batteries. These batteries are sealed and maintenance free. Since they are sealed, there is no need to check the electrolyte (fluid) level. Deep-cycle batteries are designed to handle a longer and deeper discharge. Though they are similar in appearance to automotive batteries, they are not interchangeable. Automotive batteries are not designed to handle a long, deep discharge, and also are unsafe for use in power chairs.



MANDATORY! Battery posts, terminals and related accessories contain lead and lead compounds. Wear goggles and gloves when handling batteries and wash hands after handling.



WARNING! Always use two batteries of the exact same type, chemistry and amp-hour (Ah) capacity. Refer to specifications table in this manual and in the manual supplied with the battery charger for recommended type and capacities.



WARNING! Contact your authorised Pride Dealer if you have any questions regarding the batteries in your power chair.

Charging the Batteries

The battery charger is essential in providing long life for your power chair batteries. It is designed to optimise your power chair's performance by charging the batteries safely, quickly and easily. The battery charger is only functional when the battery charger lead is plugged into an electrical outlet.



PROHIBITED! Removal of grounding prong can create electrical hazard. If necessary, properly install an approved 3-pronged adapter to an electrical outlet having 2-pronged plug access.



PROHIBITED! Never use an extension lead to plug in your battery charger. Plug the charger directly into a properly wired standard electrical outlet.



PROHIBITED! Do not allow unsupervised children to play near the power chair while the batteries are charging. Pride recommends that you do not charge the batteries while the power chair is occupied.



MANDATORY! Read the battery charging instructions in this manual and in the manual supplied with the battery charger before charging the batteries.



WARNING! Explosive gases may be generated while charging the batteries. Keep the power chair and battery charger away from sources of ignition such as flames or sparks and provide adequate ventilation when charging the batteries.

WARNING! You must recharge your power chair's batteries with the supplied off-board charger. Do not use an automotive-type battery charger.



WARNING! Inspect the battery charger, wiring and connectors for damage before each use. Contact your authorised Pride Dealer if damage is found.

WARNING! Do not attempt to open the battery charger case. If the battery charger does not appear to be working correctly, contact your authorised Pride Dealer.

WARNING! If the battery charger is equipped with cooling slots, then do not attempt to insert objects through these slots.



WARNING! If your battery charger has not been tested and approved for outdoor use, then do not expose it to adverse or extreme weather conditions. If the battery charger is exposed to adverse or extreme weather conditions, then it must be allowed to adjust to the difference in environmental conditions before use indoors. Refer to the manual supplied with the battery charger for more information.



VI. BATTERIES AND CHARGING

To charge the batteries using the off-board charger:

1. Position your power chair next to a standard electrical outlet.
2. Be certain the controller power is turned off.
3. Plug the off-board charger into the off-board charger/programming socket on the controller.
4. Plug the off-board charger into the electrical outlet.

NOTE: *If it is a Pride off-board charger, then there are two lights in it. The red light indicates that power to the off-board charger is on. The green light indicates that the batteries are fully charged. If it is not a Pride off-board charger, then follow the instructions supplied by the manufacturer.*

5. When the batteries are fully charged, unplug the off-board charger from the electrical outlet and then from the controller.

NOTE: *You can remove both battery boxes from the power base and charge them using the off-board charger port located on the front battery box. The battery boxes must be connected in order to charge them. See figure 25.*

Battery Break-in

To break in new batteries for maximum efficiency:

1. Fully recharge any new battery prior to its initial use. This brings the battery up to about 90% of its peak performance level.
2. Operate your power chair throughout the house and grounds. Move slowly at first, and do not travel too far until you become accustomed to the controls and break in the batteries.
3. Give the batteries another full charge of 8 to 14 hours and operate your power chair again. The batteries will now perform at over 90% of their potential.
4. After four or five charging cycles, the batteries will top off at 100% charge and last for an extended period.

Frequently Asked Questions (FAQs)

How does the charger work?

The battery charger takes the standard electrical outlet voltage of 120 VAC (alternating current) and converts it to 24 VDC (direct current). The power chair batteries use direct current to run your power chair. When the battery voltage is low, the charger works harder to charge the battery. As the battery voltage approaches full charge, the charger does not work as hard to complete the charging cycle. When the battery is fully charged, the amperage from the charger is nearly at zero. This is how the charger maintains a charge but does not overcharge the battery.

Can I use a different battery charger?

You should use the charger supplied with the power chair. It is the safest, most efficient tool to charge the batteries. We do not recommend using other types of chargers (e.g., an automotive battery charger).

NOTE: *Your power chair's charger will not operate after the batteries have been discharged to nearly zero voltage. If this happens, call your authorised Pride Dealer for assistance.*

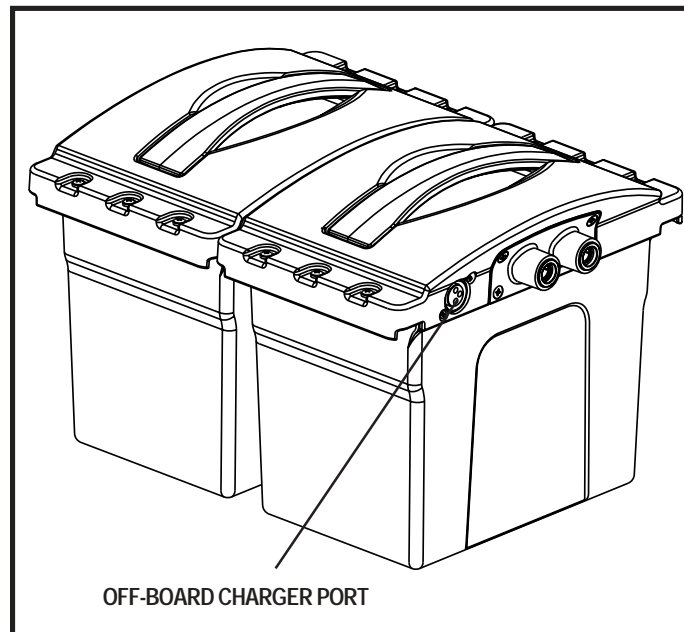

Figure 25. Battery Boxes (Removed from Power Base)

VI. BATTERIES AND CHARGING

How often must I charge the batteries?

Many factors come into play when deciding how often to charge the batteries. You may use your power chair all day on a daily basis or you may not use it for weeks at a time.

■ Daily Use

If you use your power chair on a daily basis, charge the batteries as soon as you are finished using your power chair. Your power chair will be ready each morning to give you a full day's service. It is recommended that you charge the batteries 8 to 14 hours after daily use.

■ Infrequent Use

If you use your power chair infrequently (once a week or less), you should charge the batteries at least once per week for 12 to 14 hours.

NOTE: Keep your batteries fully charged and avoid deeply discharging your batteries. Do not charge the batteries for more than 24 hours at a charging cycle.

How can I get maximum range or distance per charge?

Rarely do you have an ideal driving situation such as smooth, flat, hard terrain with no wind, hills or curves. More often you are presented with hills, pavement cracks, uneven and loosely packed surfaces, curves and wind. All of these factors will affect the distance or running time per battery charge. Below are a few suggestions for obtaining the maximum range per charge:

- Always charge the batteries fully prior to your trip.
- Plan your trip in advance to avoid inclines if possible.
- Limit baggage weight to essential items.
- Try to maintain an even speed and avoid stop-and-go driving.

What type of batteries should I use?

We recommend deep-cycle batteries that are sealed and maintenance free. Both AGM and Gel-Cell are deep-cycle batteries that are similar in performance. Refer to the specifications table for more battery information.



WARNING! Corrosive chemicals contained in batteries. Use only AGM or Gel-Cell batteries to reduce the risk of leakage or explosive conditions.

Why do my new batteries seem weak?

Deep-cycle batteries employ a much different chemical technology than that used in car batteries, nickel-cadmium (nicads) or in other common battery types. Deep-cycle batteries are specifically designed to provide power, drain down their charge and then accept a relatively quick recharge. AGM and Gel-Cell batteries should be charged as often as possible. They do not have a “memory” like nickel-cadmium batteries.

We work closely with our battery manufacturer to provide a battery that best suits your power chair's specific demands. Fresh batteries arrive regularly at Pride and are promptly shipped with a full charge. During shipping, the batteries encounter temperature extremes that may influence initial performance. Heat robs the charge from the battery, and cold slows the power available and extends the time needed to recharge the battery (just as with a car battery).

VI. BATTERIES AND CHARGING

It might take a few days for the temperature of the battery to stabilise and adjust to its new ambient temperature. More importantly, it will take a few “charging cycles” (a partial drain— then a full recharge) to establish the critical chemical balance that is essential to the battery’s peak performance and long life. It will be well worth it to take the time to break in your battery properly.

NOTE: The useful life of a battery is quite often a reflection of the care it receives.

How can I ensure maximum battery life?

A fully charged deep-cycle battery will provide reliable performance and extended battery life. Keep your power chair’s batteries fully charged whenever possible. Batteries that are regularly and deeply discharged, infrequently charged or stored without a full charge may be permanently damaged, causing unreliable power chair operation and limited battery life.

How should I store my power chair and its batteries?

If you do not use your power chair regularly, we recommend maintaining battery vitality by charging the batteries at least once per week.

If you do not plan on using your power chair for an extended period, fully charge the batteries prior to storage. Disconnect the battery harnesses and store the power chair in a warm, dry environment. Avoid temperature extremes, such as freezing or excessively hot conditions, and never attempt to charge a frozen battery. A cold or frozen battery should be warmed for several days prior to recharging.

What about public transportation?

AGM and Gel-Cell batteries are designed for application in power chairs and other mobility vehicles. These batteries are Federal Aviation Administration (FAA) approved, allowing safe transportation on aircraft, buses and trains, as there is no danger of spillage or leakage. We suggest you contact the carrier’s ticket counter in advance to determine that carrier’s specific requirements.

What about shipping?

If you wish to use a freight company to ship your power chair to your final destination, repack your power chair in the original shipping container and ship the batteries in separate boxes.

VII. CARE AND MAINTENANCE

CARE AND MAINTENANCE

Your Jazzy 1107 is a sophisticated power chair. Like any motorised vehicle, it requires routine maintenance checks. You can perform some of these checks, but others require assistance from your authorised Pride Dealer. Preventive maintenance is very important. If you follow the maintenance checks in this section as scheduled, you can help ensure that your power chair gives you years of trouble-free operation. If you have any doubt as to your power chair's care or operation, contact your authorised Pride Dealer.



WARNING! Do not service the power chair when the seat is occupied.

Your power chair, like most electrical equipment, is susceptible to damage from the elements. Avoid damp areas of any kind.



WARNING! Direct or prolonged exposure to water or dampness could cause the power chair to malfunction electronically and mechanically. Water can cause electrical components to corrode and the chair's frame to rust. Power chairs should be examined periodically for signs of corrosion caused by water exposure, bodily fluids exposure or incontinence. Damaged components should be replaced or treated immediately.



Should your power chair come in contact with water:

1. Dry your power chair as thoroughly as possible with a towel.
2. Allow your power chair to sit in a warm, dry place for 12 hours to allow unseen water to evaporate.
3. Check the joystick operation and the brakes before using your power chair again.
4. If any inconsistencies are found, take your power chair to your authorised Pride Dealer. Power chairs that are frequently exposed to sources of water, such as incontinence, should be inspected often for corrosion and electronic components may need to be replaced frequently.

Temperature

- Some of the parts of your power chair are susceptible to extreme changes in temperature. Always keep your power chair between the temperatures of -8°C (18° F) and 50°C (122° F).
- In extremely cold temperatures the batteries may freeze. The specific temperature at which they freeze depends on a number of factors, such as battery charge, usage and composition of the batteries (e.g., AGM or Gel-Cell).
- Temperatures above 50°C (122° F) may cause your power chair to operate at a reduced speed. This reduced speed is a safety feature built into the controller that helps prevent damage to the motor and other electrical components.

General Guidelines

- Avoid knocking or bumping the controller, especially the joystick.
- Avoid prolonged exposure of your power chair to extreme conditions, such as heat, cold or moisture.
- Keep the controller clean.
- Check all connectors to ensure that they are all tight and secured properly.
- Make sure the drive tyres are inflated to **2.4 bar (35 psi)** if equipped with pneumatic tyres.



WARNING! Make sure your tyres are inflated to 2.4 bar (35 psi). Do not underinflate or overinflate your tyres. Low pressure may result in loss of control, and overinflated tyres may burst. Overinflating tyres can cause them to explode.

WARNING! Do not use a high pressure hose to inflate your tyres.

- Use a rubber conditioner on the tyre sidewalls to help preserve them.



WARNING! Never use a rubber conditioner on the tread area of the tyres; doing so may make the tyres slippery and cause your power chair to skid.

VII. CARE AND MAINTENANCE

- All wheel bearings are prelubricated and sealed. They require no subsequent lubrication.
- The body shroud has been sprayed with a clear sealant coating. You can apply a light coat of car wax to help it retain its high-gloss appearance.
- Check all electrical connections. Make sure they are tight and are not corroded. Batteries must sit flat within the battery well, with the battery terminals facing inward, toward each other. Refer to the frame decal for the correct wiring layout.



WARNING! Even though the power chair has passed the necessary testing requirements for ingress of liquids, you should keep electrical connections away from sources of dampness, including direct exposure to water or bodily fluids and incontinence. Check electrical components frequently for signs of corrosion and replace as necessary.

Daily Checks

- With the controller turned off, check the joystick. Make sure it is not bent or damaged and that it returns to the neutral position when you release it. Check the rubber boot around the base of the joystick for damage. Visually inspect the boot. Do not handle or try to repair it. See your authorised Pride Dealer if there is a problem.
- Visually inspect the controller cable. Make sure that it is not frayed, cut or has any wires exposed. See your authorised Pride Dealer if there is a problem.
- Check for flat spots on solid tyres. Flat spots could adversely affect stability.
- Inspect the armrests for loose hardware, stress points or damage. See your authorised Pride Dealer if there is a problem.

Weekly Checks

- Disconnect and inspect the controller battery door. Look for corrosion. Contact your authorised Pride Dealer if necessary.
- Ensure that all parts of the controller system are securely fastened to your power chair. Do not overtighten any screws.
- Check for proper tyre inflation. There should be **2.4 bar (35 psi)** in each tyre if equipped with pneumatic tyres. If a tyre does not hold air, see your authorised Pride Dealer for replacement of the tube.
- Check the brakes. This test should be carried out on a level surface with at least 1 meter (3 feet) of clearance around your power chair.

To check the brakes:

1. Turn on the controller and turn down the speed level of your power chair.
2. After one second, check the battery condition meter. Make sure that it remains on.
3. Slowly push the joystick forward until you hear the electromagnetic brakes click. Immediately release the joystick. You must be able to hear each electromagnetic brake operating within a few seconds of joystick movement. Repeat this test three times, pushing the joystick rearward, then left and then right.

Monthly Checks

- Check that the anti-tip wheels do not rub the ground when you operate the power chair. Adjust them as necessary. See V. “Comfort Adjustments.”
- Check for extreme wear on the anti-tip wheels. Replace them as necessary.
- Check for drive tyre wear. See your authorised Pride Dealer for repair.
- Check the castor wheels for wear. Replace them as necessary.
- Check the castor forks for damage or fluttering which indicates that they may need to be adjusted or have the bearings replaced. See your authorised Pride Dealer for repair.
- Keep your power chair clean and free of foreign material, such as mud, dirt, hair, food, drink, etc.

VII. CARE AND MAINTENANCE

Yearly Checks

Take your power chair to your authorised Pride Dealer for yearly maintenance, especially if you use your power chair on a regular basis. This helps ensure that your power chair is functioning properly and helps prevent future complications.

Storage

Your power chair should be stored in a dry place, free from temperature extremes. When storing, disconnect the batteries from the power chair. See VI. “Batteries and Charging.”



WARNING! If you fail to store the unit properly, the frame can rust and the electronics can be damaged.

Batteries that are regularly and deeply discharged, infrequently charged, stored in extreme temperatures or stored without a full charge may be permanently damaged, causing unreliable performance and limited service life. It is recommended that you charge the batteries periodically throughout periods of prolonged storage to ensure proper performance.

You may wish to place several boards under the frame of your power chair to raise it off of the ground during periods of prolonged storage. This takes the weight off the tyres and reduces the possibility of flat spots developing on the areas of the tyres contacting the ground.

Disposal of Your Power Chair

Your power chair must be disposed of according to applicable local and national statutory regulations. Contact your local waste disposal agency or authorised Pride Dealer for information on proper disposal of power chair packaging, metal frame components, plastic components, electronics and batteries.

Cleaning and Disinfection

- Use a damp cloth and mild, non-abrasive cleanser to clean the plastic and metal parts of your power chair. Avoid using products that may scratch the surface of your power chair.
- If necessary, clean your product with an approved disinfectant. Make sure the disinfectant is safe for use on your product before application.

WARNING! Follow all safety instructions for the proper use of the disinfectant and/or cleaning agent before applying it to your product. Failure to comply may result in skin irritation or premature deterioration of upholstery and/or power chair finishes.



WARNING! Never hose off your power chair or place it in direct contact with water. Your power chair has a painted, ABS plastic body shroud that allows it to be easily wiped clean with a damp cloth.

WARNING! Never use any chemicals to clean a vinyl seat, as they may cause the seat to become slippery or dry out and crack. Use soapy water and dry the seat thoroughly.

Wheel Replacement

If you have pneumatic tyres and you have a flat tyre, you can replace the tube. If your chair is equipped with a solid tyre insert, then you must replace the entire wheel assembly. Replacement tyres, tubes and wheel assemblies are readily available through your authorised Pride Dealer.

WARNING! The wheels on your power chair should only be serviced or replaced by an authorised Pride Dealer or a qualified technician.



WARNING! Be sure that the controller's power is turned off and the power chair is not in freewheel mode before performing this procedure.

WARNING! When changing a tyre, remove only the centre lug nut and washer, then remove the wheel. If any further disassembly is required, deflate the tyre completely or it may explode.

VII. CARE AND MAINTENANCE

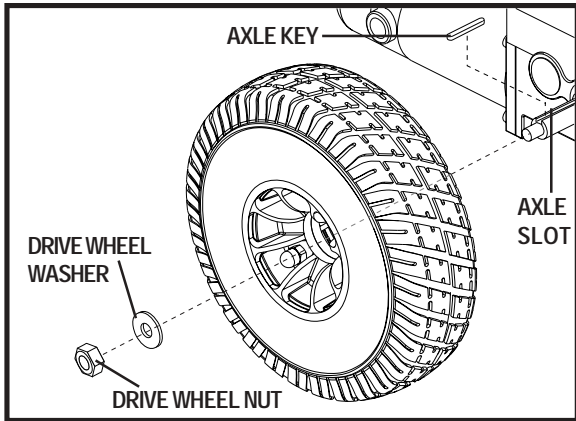

Figure 26. Jazzy 1107 Drive Wheel

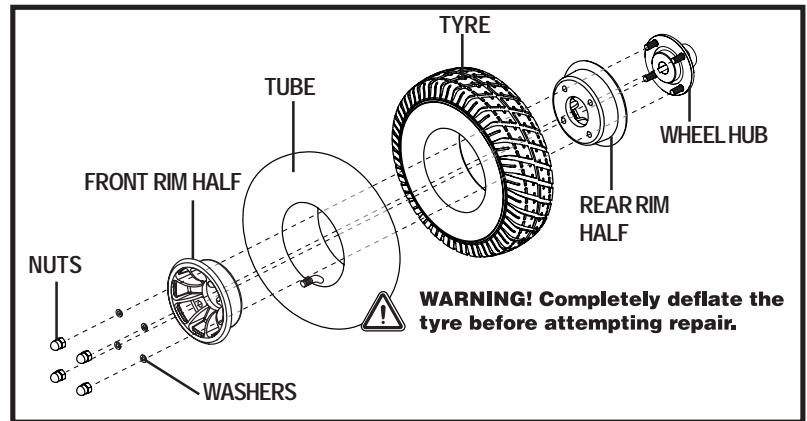

Figure 27. Jazzy 1107 Drive Wheel Disassembled

Follow these easy steps for a quick and safe repair for both pneumatic and solid tyres:

1. Turn off the power to the controller.
2. Set the power chair up on blocks.
3. If you are changing a pneumatic tyre, completely deflate it before removing the wheel.
4. Remove the drive wheel nut and washer from the axle. See figure 26.
5. Pull the wheel off the axle.
6. Remove the nuts and washers from the wheel hub and separate the front and rear rim. See figure 27.
7. Remove the old tube from the pneumatic tyre and replace it with a new tube or replace the entire assembly if it is a solid tyre.
8. Reassemble the rim assembly and reinstall the nuts and washers to the wheel hub.
9. Slide the wheel back onto the axle. Make sure the key is in the axle slot.
10. Reinstall the drive wheel nut and washer onto the axle and tighten.
11. Inflate the pneumatic tyres to **2.4 bar (35 psi)**.
12. Remove the power chair from the blocks.

Battery Replacement

A battery wiring diagram is printed on a decal located inside the battery box lid. See VI. “Batteries and Charging” for correct battery specifications.



MANDATORY! Battery posts, terminals, and related accessories contain lead and lead compounds. Wear goggles and gloves when handling batteries and wash hands after handling.

WARNING! Do not replace battery when seat is occupied.

WARNING! The batteries on your power chair should only be serviced or replaced by an authorised Pride Dealer or a qualified technician.



WARNING! Power chair batteries are heavy. See specifications table. If you are unable to lift that much weight, be sure to get help. Use proper lifting techniques and avoid lifting beyond your capacity.

WARNING! Do not mix or match new and old batteries. If you encounter a situation where one battery needs to be replaced, then replace both batteries. Refer to the specifications table in this manual and the manual supplied with the battery charger for recommended type and capacities.

VII. CARE AND MAINTENANCE

To replace the batteries:

1. Turn off the power to the controller.
2. Make sure that the power chair is in drive mode. See III. "Your Power Chair."
3. Remove the battery boxes. See IV. "Assembly/Disassembly."
4. Disconnect the wiring harness from the batteries.
5. Remove the batteries from the battery boxes.
6. Place new batteries in the battery boxes. See figure 28.
7. Reconnect the battery harnesses according to the battery wiring diagram label. See figure 29.



WARNING! Make sure you tighten the fasteners so that the connections are secure.

8. Reinstall the battery boxes onto the power base. Make sure that the battery box latches are in the up (locked) position.
9. Charge the batteries. See VI. "Batteries and Charging."

When to See Your Authorised Pride Dealer for Service

The following symptoms could indicate a serious problem with your power chair. If necessary, contact your authorised Pride Dealer. When calling, have the model number, serial number, nature of the problem and the error code if available.

- Motor noise
- Frayed harnesses
- Cracked or broken connectors
- Uneven wear on any of the tyres
- Jerky motion
- Pulling to one side
- Bent or broken wheel assemblies
- Does not power up
- Powers up, but does not move

Corrective Maintenance

If the battery condition meter does not light up when you turn on the power:

- Check the harness connections. Make sure they are tight.
- Check the circuit breaker. Reset it if necessary.
- Check the battery connections.

If the above conditions prove normal, you can load test the batteries with a battery load tester. These testers are available at automotive parts stores. Disconnect both batteries before load testing and follow the directions that come with the load tester. If either one of the batteries fails the load test, replace both of them. If your power chair still does not power up, contact your authorised Pride Dealer.

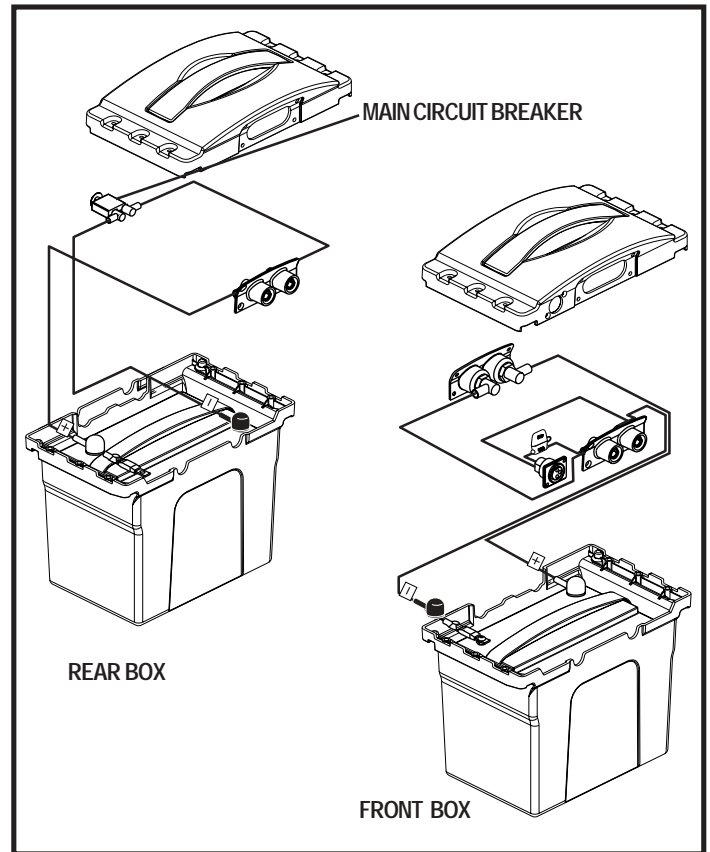

Figure 28. Battery Boxes

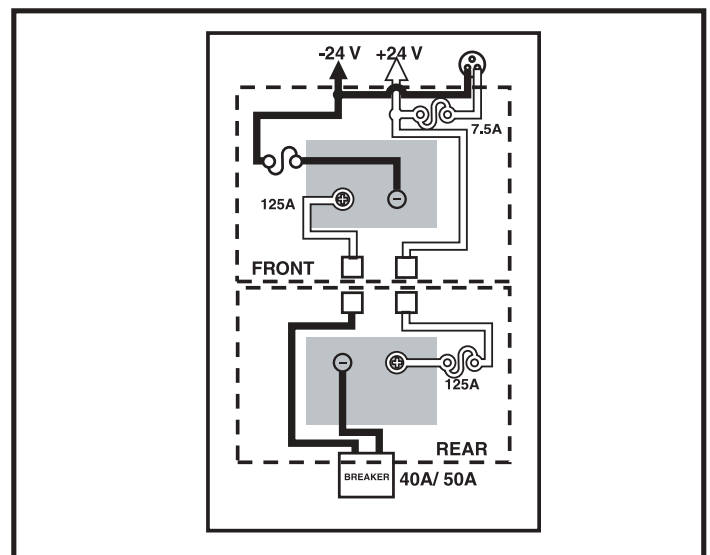

Figure 29. Battery Wiring Diagram

V I I I . W A R R A N T Y

LIFETIME WARRANTY

Structural frame components, including: platform, fork, seat post and frame welds.

TWO-YEAR LIMITED WARRANTY

Drivetrain, including: motor and brake.

EIGHTEEN-MONTHS LIMITED WARRANTY

Controllers: Any attempt to open or dismantle these parts will lead to this warranty being void.

ONE-YEAR LIMITED WARRANTY

All electrical parts, including battery chargers, are covered for one year under warranty. Any attempt to open or dismantle these parts will lead to this warranty being void.

BATTERIES

Batteries are covered by a twelve-month warranty from the original manufacturer.

NOT COVERED UNDER WARRANTY

The following parts are classed as wear items, which may, under normal wear and tear, require replacing. These items are **not** therefore covered under warranty: tyres, positioning belts, bulbs, upholstery, plastic shrouds, motor brushes, fuses and batteries. Warranty will also be refused if damage is deemed to have been caused through misuse or accident for which Pride Mobility Products Ltd. cannot be deemed responsible.

NOTE: Pride Mobility Products Ltd. provides parts only under warranty. Your authorised Pride Dealer is responsible for labour and service. Please contact your authorised Pride Dealer for information about these services and for any applicable charges.

APPENDIX I - SPECIFICATIONS

SPECIFICATIONS	
Suspension:	Active Trac
Drive Wheels:	25.4 cm (10 in.), pneumatic or solid available
Castor Wheels:	15.25 cm (6 in.), solid, rear-mounted
Anti-tip Wheels:	12.7 cm (5 in.), solid, front-mounted
Maximum Speed: ¹	Up to 7.25 km/h (4.5 mph)
Range: ¹	Up to 17 km (11 miles)
Brakes:	“Intelligent Braking” electronic regenerative, disc park brake
Ground Clearance: ²	See figure 30.
Turning Radius: ²	See figure 30.
Overall Size: ²	Length: See figure 30. Width: See figure 30.
Drivetrain:	Two motor, mid-wheel drive
Batteries: ³	Two 12-volt, U-1 batteries
Battery Charger:	5-amp, off-board
Weight Capacity:	136 kg (21 stone/300 lbs.)
Component Weights:	Base: 44.45 kg (98 lbs.) Right Section: 18.37 kg (40.5 lbs.) Left Section: 18.37 kg (40.5 lbs.) Centre Section: 7.7 kg (17 lbs.) Medium-Back Seat: 16.78 kg (37 lbs.) average weight with armrests and universal mounting system Batteries: 13.15 kg (29 lbs.) each Battery Boxes: 2.04 kg (4.5 lbs.) each

¹ Varies with base model, user weight, terrain type, battery amp hour rating (Ah), battery charge, battery condition, motors, controller type, tyre type and tyre condition.

² Due to manufacturing tolerances and continued product improvement, this specification can be subject to variance of (+ or -) 3%.

³ AGM or Gel-Cell type required. See VI. “Batteries and Charging.”

NOTE: All specifications subject to change without notice.

APPENDIX I - SPECIFICATIONS

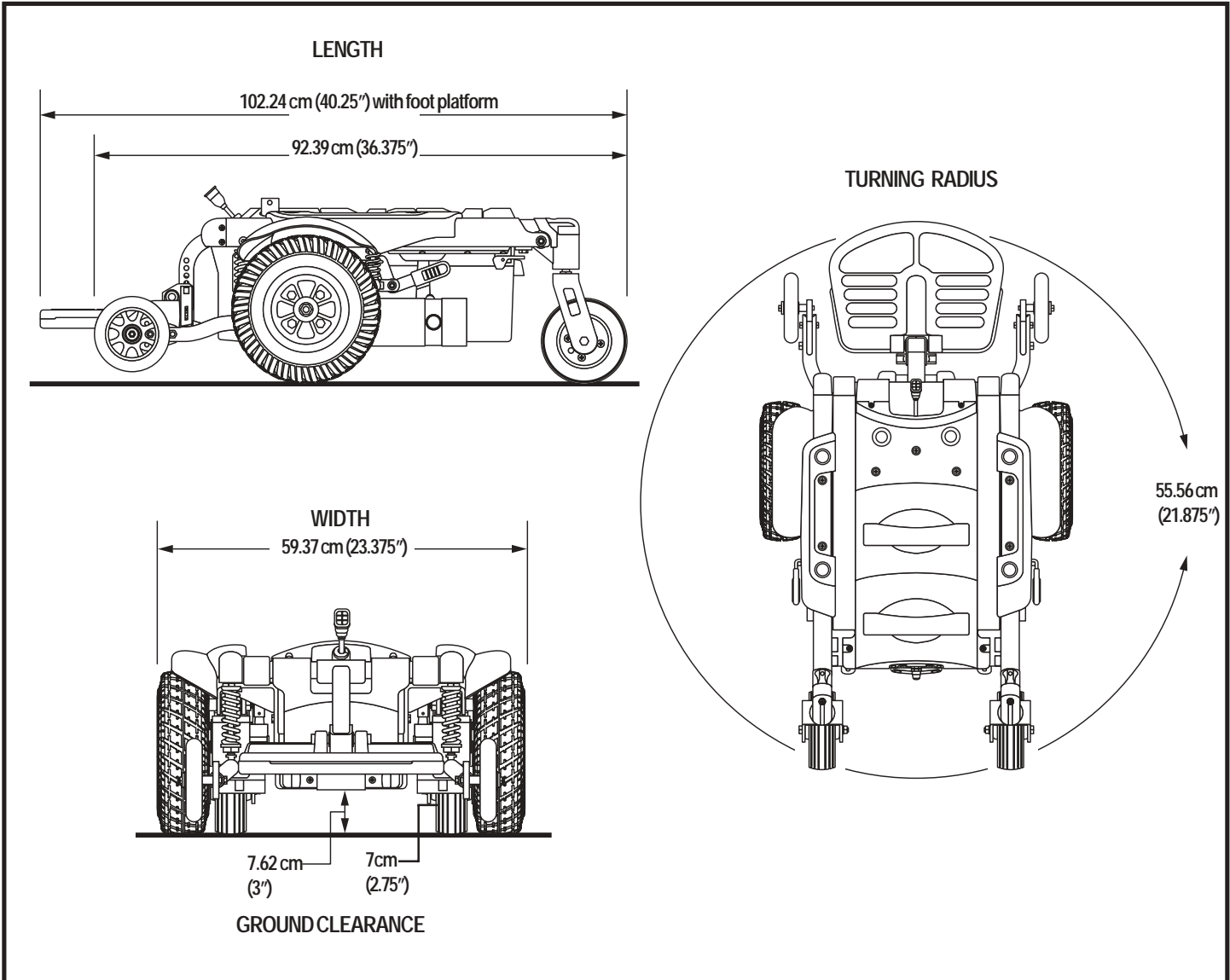

Figure 30. Jazzy 1107 Dimensions and Ground Clearance

Quality Control - Jazzy 1107

Inclusion of all Parts

Joystick Serial Number

Controller Serial Number

Left Motor Serial Number

Right Motor Serial Number

Fit and Finish

Performance



Pride keeps a more detailed report on file at the factory.

Date Inspected

Inspector

* I NFMANU2846 *

Product Serial Number