

Model 5503 Series

E & H Field Generator

2-Meter, 3-Meter, 5-Meter

User Manual



Model 5503-5M shown

 **ETS-LINDGREN**[™]
An ESCO Technologies Company

ETS-Lindgren L.P. reserves the right to make changes to any product described herein in order to improve function, design, or for any other reason. Nothing contained herein shall constitute ETS-Lindgren L.P. assuming any liability whatsoever arising out of the application or use of any product or circuit described herein. ETS-Lindgren L.P. does not convey any license under its patent rights or the rights of others.

© Copyright 2005–2008 by ETS-Lindgren L.P. All Rights Reserved. No part of this document may be copied by any means without written permission from ETS-Lindgren L.P.

Trademarks used in this document: The *ETS-Lindgren* logo is a trademark of ETS-Lindgren L.P.

Revision Record
MANUAL,5503 EH FIELD GENERATOR | Part #399773, Rev. B

Revision	Description	Date
A	Initial Release	November, 2005
B	Added 5503-2M & 5503-3M; rebrand	December, 2008

Table of Contents

Notes, Cautions, and Warnings	v
1.0 Introduction	7
ETS-Lindgren Product Information Bulletin	7
2.0 Maintenance	9
Maintenance Recommendations	9
Service Procedures	9
3.0 Specifications	11
Electrical Specifications	11
Physical Specifications	11
4.0 Assembly and Installation	13
Support Structure.....	14
Antenna Elements	16
Cables.....	17
5.0 Operation	19
Antenna Elements	19
Model 5503-5M E-Mode / H-Mode	20
Model 5503-5M: E-Mode Operation	21
Model 5503-5M: From E-Mode to H-Mode	22
Model 5503-5M: H-Mode Operation	23
Model 5503-5M: Load Cable Connections	23
Model 5503-5M: Grounding	24
Model 5503-2M & 5503-3M: E-Mode / H-Mode.....	25
Model 5503-2m & 5503-3M: Change Low Power Balun Boxes	26
Model 5503-2M & 5503-3M: Rotate Antenna Elements	28
Model 5503-2M & 5503-3M: E-Mode Operation.....	29
Model 5503-2M & 5503-3M: H-Mode Operation	30
Model 5503-2M & 5503-3M: Load Cable Connections.....	31
Model 5503-2M & 5503-3M: Grounding	32
Typical Test Setup	33
Model 5503-5M VSWR.....	33
Model 5503-5M Power Requirements, 100 V/M.....	34
Storage	34

Appendix A: Warranty	35
Appendix B: Assembly Drawings	37
Frame Assembly.....	37
Element Installation	38
Framing Element (Strut) Installation	39
Antenna Orientation.....	40

Notes, Cautions, and Warnings

	Note: Denotes helpful information intended to provide tips for better use of the product.
CAUTION	Caution: Denotes a hazard. Failure to follow instructions could result in minor personal injury and/or property damage. Included text gives proper procedures.
WARNING	Warning: Denotes a hazard. Failure to follow instructions could result in SEVERE personal injury and/or property damage. Included text gives proper procedures.



See the ETS-Lindgren *Product Information Bulletin* for safety, regulatory, and other product marking information.

This page intentionally left blank.

1.0 Introduction

The **ETS-Lindgren Model 5503 Series E&H Field Generator** creates a vertical or horizontal electric field. This two-conductor transmission line system consists of parallel radiating elements attached to a non-conductive, non-metallic frame, as well as a load and balun boxes that are mounted on the frame and attached to the ground plane. The Model 5503 is available in three sizes: 2-meter, 3-meter, and 5-meter.

The two operating modes of the field generator are:

- **E-Mode (Common)**—When the current on the two radiating elements flows in the same direction, a vertical E-field is the dominant field component. Field distribution simulates that of a quasi-static parallel-plate transverse electromagnetic mode (TEM).
- **H-Mode (Differential)**—When the current on the two radiating elements flows in the opposite direction, a vertical H-field or a horizontally polarized E-field is the dominant field component. Field distribution is approximately that of a quasi-static two-wire transmission line. A balun is used to isolate the elements from the ground plane.

The Model 5503-2M and Model 5503-3M include two plug-in low power balun boxes, one for E-field operation and one for H-field operation. The Model 5503-5M includes one high power balun box for either E-field operation or H-field operation.

ETS-Lindgren Product Information Bulletin

See the ETS-Lindgren *Product Information Bulletin* included with your shipment for the following:

- Warranty information
- Safety, regulatory, and other product marking information
- Steps to receive your shipment
- Steps to return a component for service
- ETS-Lindgren calibration service
- ETS-Lindgren contact information

This page intentionally left blank.

2.0 Maintenance

CAUTION

Before performing any maintenance, follow the safety information in the ETS-Lindgren *Product Information Bulletin* included with your shipment.



Maintenance of the Model 5503 is limited to external components such as cables or connectors.

If you have any questions concerning maintenance, contact ETS-Lindgren Customer Service.

Maintenance Recommendations

Periodically check for wear on the cables that extend from the antenna elements to the load and balun boxes.

Service Procedures

For the steps to return a system or system component to ETS-Lindgren for service, see the *Product Information Bulletin* included with your shipment.

This page intentionally left blank.

3.0 Specifications

Electrical Specifications

	Low Power Balun Box	High Power Balun Box
Frequency Range:	100 kHz–30 MHz	100 kHz–30 MHz
Continuous Input Power:	1 kW	3 kW
Input Impedance:	50 Ω	50 Ω
Transmit Line Impedance:	~200 Ω H-mode ~100 Ω E-mode	~200 Ω H-mode ~100 Ω E-mode
Connectors:	<ul style="list-style-type: none"> Type N, female One per balun box 	1 5/8-in EIA flange (2)
VSWR:	<3.25:1 H <4.25:1 E	<3.25:1 H <4.25:1 E



See *Model 5503-5M VSWR* on page 33.

The VSWR is less than 2.5 for most of the range for both polarizations. The generator can be used as low as 10 kHz but the VSWR is higher, reaching values of 9:1.

Physical Specifications

	2-Meter	3-Meter	5-Meter
Length:	4.65 m (15.25 ft)	5.64 m (18.5 ft)	7.65 m (25.0 ft)
Width:	1.79 m (5.9 ft)	1.79 m (5.9 ft)	1.79 m (5.9 ft)
Height:	2.75 m (9.0 ft)	2.75 m (9.0 ft)	2.75 m (9.0 ft)

This page intentionally left blank.

4.0 Assembly and Installation

CAUTION

Before assembling or installing any components, follow the safety information in the ETS-Lindgren *Product Information Bulletin* included with your shipment.

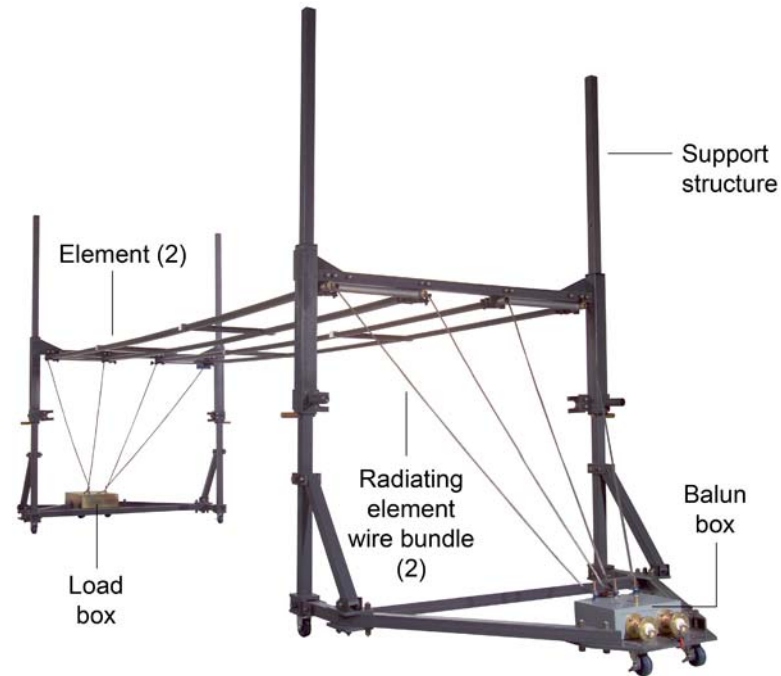

*Model 5503-5M shown
with high power balun box*

The Model 5503 Series E & H Field Generator consists of the following components:

- Non-conductive, non-metallic support structure, including four masts that enable the vertical movement of the element carriers.
- Two antenna elements, each consisting of a rectangular frame.

- Elements connect to a load box and a balun box through radiating element wire bundles. Each radiating element wire bundle assembly consists of two pieces of conductive braid over rope and a spring retraction system housed in an aluminum tube assembly.



A metal ground plane with minimum dimensions of 8 m x 3 m x 1/16 in (not included) must be centered under the Model 5503.

Support Structure

CAUTION

A minimum of four people are required to safely assemble and operate the Model 5503.



See *Assembly Drawings* on page 37 for additional assembly and installation illustrations.

The support structure is shipped partially assembled. To complete assembly, set the vertical supports upright and secure with framing elements (struts).

1. Unfold the support structure so that the masts and element supports are straight and at 90 degrees to the base.



2. Rotate the two framing elements and insert them into the receiving brackets on the upright elements.

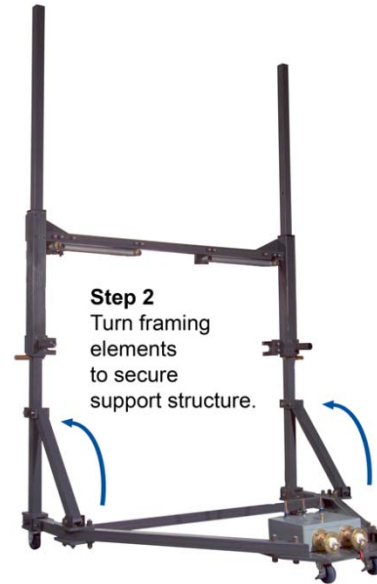

3. Insert the bolt assembly into each framing element: Insert the cylinder or bushing through the hole and then insert the bolt and fasten it on both sides with the nuts.



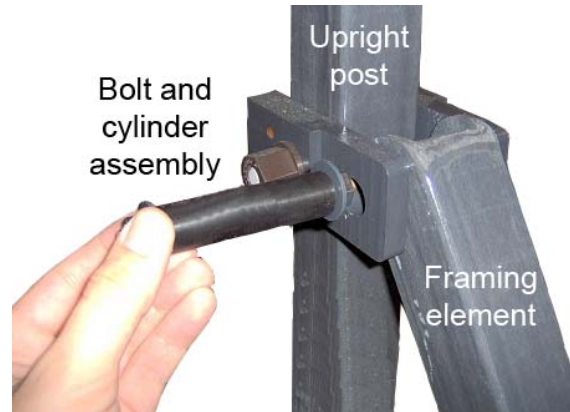

4. Repeat these steps to assemble the remaining vertical support.

Antenna Elements

When both sides of the support structure are completely assembled, attach the antenna elements:

1. Space the two pieces of the support structure approximately five meters (16 feet) apart.
2. Slide the ends of the antenna elements into the two clamps. One clamp is located near the top of the carrier and the other on the side of the carrier near the bottom.
3. Insert the threaded knobs through the holes near the outer edge, and then tighten the knobs. These knobs hold the elements in place inside the U-shaped receptacle.

When both ends of each antenna element are secured in place, the antennas can be positioned. See *Operation* on page 19 for information on antenna orientation.

Cables

CAUTION

To protect your hands, use gloves when extending or retracting the cables.



Four cables extend down to the load box and balun box from the ends of each radiating element. These cables must be disconnected and reconnected each time the radiating elements are moved up and down, when changing from E-field mode to H-field mode.

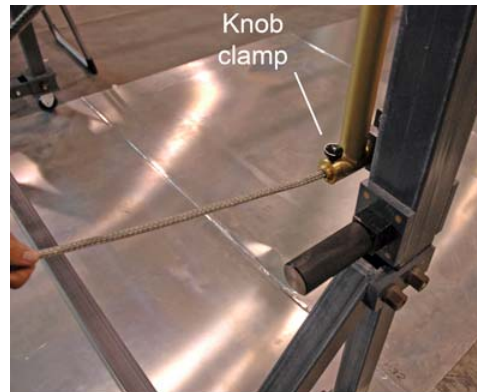

Cables extend from and retract into elements

The cables extend from and retract into the antenna elements. The knob clamp at each end of the element ensures good contact.



Each cable is terminated at a post on the load box or balun box. Only one cable may be connected to each post. Secure the cable into place with a wing nut.

To connect the cables:

1. Loosen the knob clamp on the antenna element around the cable.
2. Pull the connecting loop out from the element and over to the corresponding connection post on the load box or balun box.
3. Remove the nut and the top washer from the post and slide the connecting loop into place on the post then replace the washer and nut. Securely tighten the nut for good contact.
4. Tighten the knob clamp on the antenna element around the cable.

5.0 Operation

CAUTION

Before connecting any components or operating the Model 5503, follow the safety information in the ETS-Lindgren *Product Information Bulletin* included with your shipment.

WARNING

Testing with the Model 5503 should not be conducted in an area where the field generated could cause disruption to other equipment. This unit must be used in a screen or shielded enclosure.

WARNING

The operator should limit exposure to the field generated by this device.

Antenna Elements

Two conductor cables on each of the elements extend downward to connect the elements to the load box and balun box. The conductive cables extend and retract out of the elements depending on the distance to the connection point on the load box and balun box. For more information, see *Cables* on page 17.

Four masts extend upward to allow the carriers to slide up and down. The masts, in conjunction with the carriers and phenolic pins (pegs), allow vertical adjustment to 1.5 m, 2 m, and 2.5 m.

The pegs are installed through the masts to hold the carrier in any of the three preset positions. The carrier handle (knob) on each carrier can be turned to clamp the carrier at other heights on the masts.

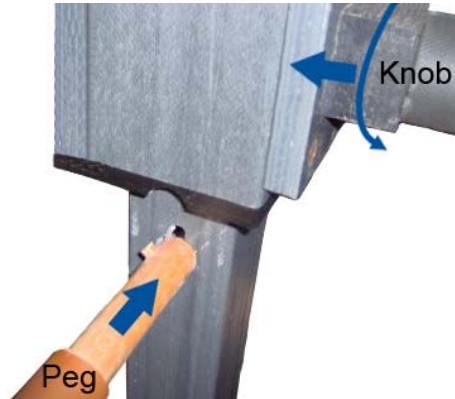

To raise or lower elements:

1. Remove the peg.
2. Loosen the knob.
3. Adjust the height.
4. Re-insert the peg for the desired height.
5. Tighten the knob.

Model 5503-5M E-Mode / H-Mode

The Model 5503-5M E&H Field Generator includes a high power balun box for either E-field or H-field operation. The connectors and posts on the box are labeled according to the type of operation that the generator will perform.

MODEL 5503-5M: E-MODE OPERATION

The E-field is generated when the two elements are parallel with the ground plane.

- Connect the cables from the two elements to the center post on the high power balun box labeled **E**.
- Connect the RF or power input cable to the RF connector on the high power balun box labeled **E**.

Connect cables from all elements to center post labeled **E**



Connect power input cable

High Power Balun Box

MODEL 5503-5M: FROM E-MODE TO H-MODE

CAUTION

When moving the elements up and down on the carrier, maintain the same level at all times to avoid bending or damaging the elements.

Following are the steps to rotate the antenna elements from E-mode to H-mode:

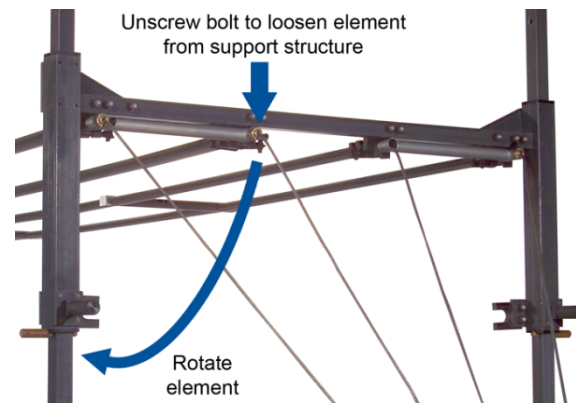

1. While holding the element, unscrew the bolt farthest from the upright element that holds the frame in position.
2. Let the element rotate 90 degrees until it rests in the U-shaped receptacle on the upright element.
3. Tighten the bolt to hold the element in position.

MODEL 5503-5M: H-MODE OPERATION

The H-field is generated when the two antenna elements are perpendicular to the ground plane.

- Connect the cables from each of the elements to each of the posts on the high power balun box labeled H.
- Connect the RF or power input cable to the RF connector on the high power balun box labeled H.

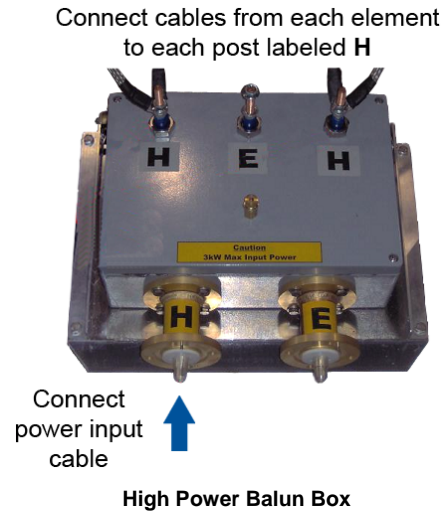

MODEL 5503-5M: LOAD CABLE CONNECTIONS

For both E-mode and H-mode operations, connect the cables from each element to the two posts on the load box.

For more information, see *Cables* on page 17.

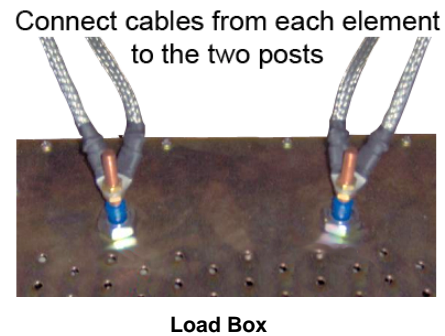

MODEL 5503-5M: GROUNDING

Before operating the Model 5503-5M, verify that the ground contact foot on the load box and balun box is attached to ground, and is grounded. This can be accomplished by using bolts (not included) that screw onto the ground plane in the shielded room.

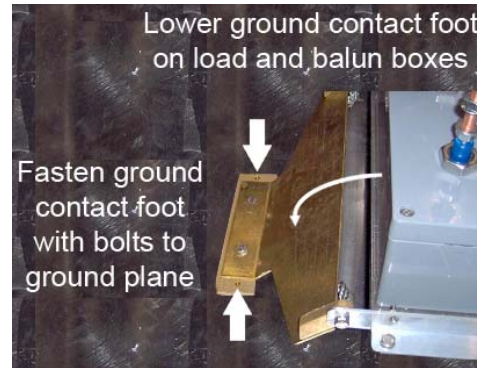

Model 5503-2M & 5503-3M: E-Mode / H-Mode

The Model 5503-2M and Model 5503-3M include one low power balun box for E-field operation and one low power balun box for H-field operation. Each box is labeled accordingly.

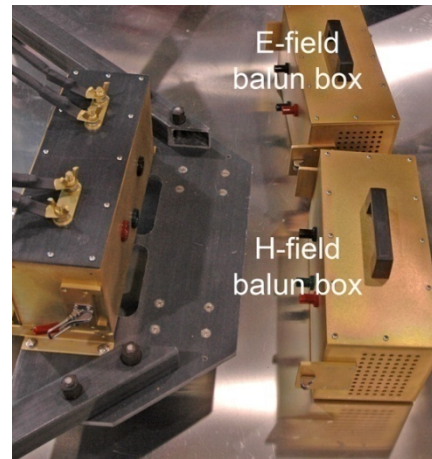

MODEL 5503-2M & 5503-3M: CHANGE LOW POWER BALUN BOXES

1. Open clip on each side of generator unit.

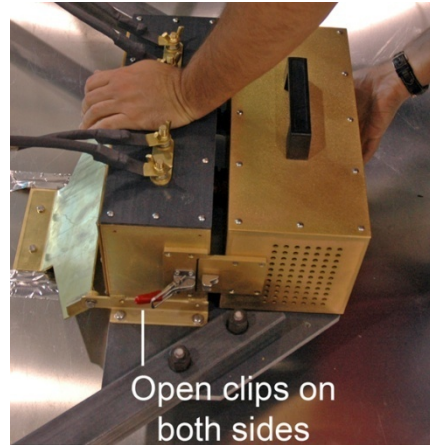

2. Carefully slide balun box away from generator unit.

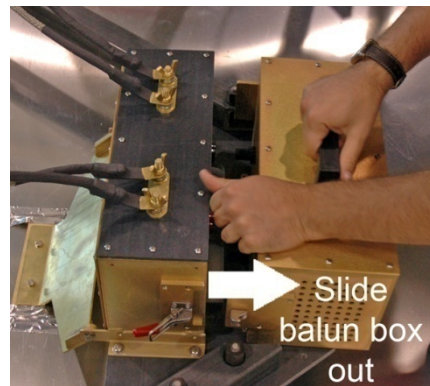

3. Slide other balun box toward generator unit so that it is flush with the unit.

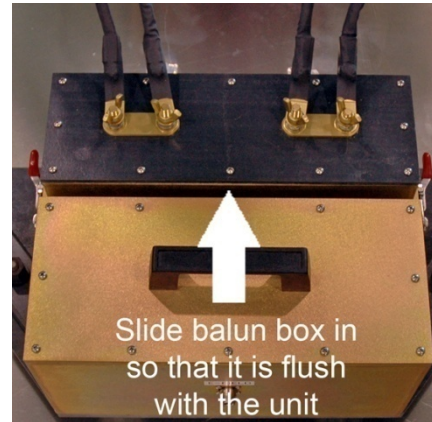

4. Close clips on both sides to secure the balun box into place.

MODEL 5503-2M & 5503-3M: ROTATE ANTENNA ELEMENTS

CAUTION

When moving the elements up and down on the carrier, maintain the same level at all times to avoid bending or damaging the elements.

Following are the steps to rotate the antenna elements from E-mode to H-mode:

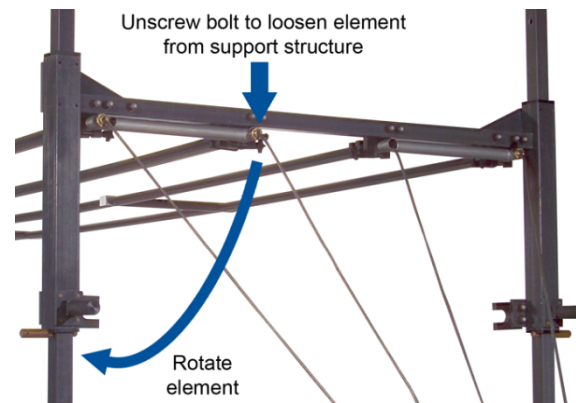

1. While holding the element, unscrew the bolt farthest from the upright element that holds the frame in position.
2. Let the element rotate 90 degrees until it rests in the U-shaped receptacle on the upright element.
3. Tighten the bolt to hold the element in position.

MODEL 5503-2M & 5503-3M: E-MODE OPERATION

The E-field is generated when the two elements are parallel with the ground plane.

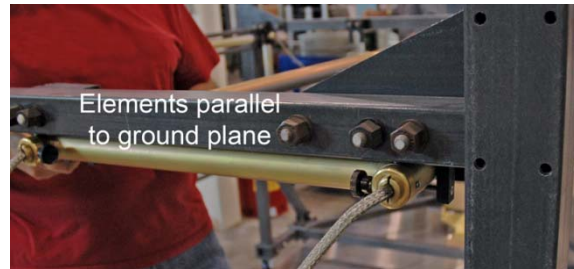

1. Connect E-field low power balun box to generator unit. See page 26 for the steps to change a balun box.
2. Rotate the elements to E-field position. See page 28 for the steps to rotate the elements.
3. Verify that the cables from the elements are connected to the generator unit.
4. Attach the RF or power input cable to the connector on the balun box.

MODEL 5503-2M & 5503-3M: H-MODE OPERATION

The H-field is generated when the two antenna elements are perpendicular to the ground plane.

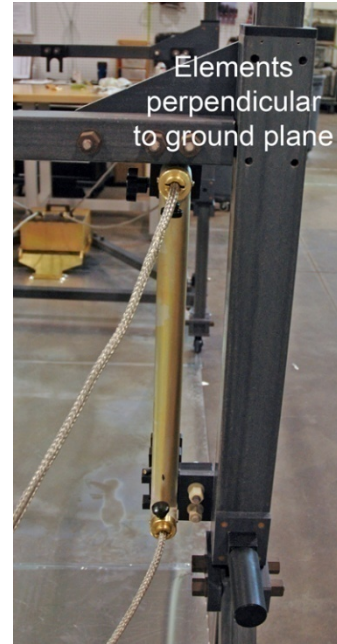

1. Connect H-field low power balun box to generator unit. See page 26 for the steps to change a balun box.
2. Rotate the elements to H-field position. See page 28 for the steps to rotate the elements.
3. Verify that the cables from the elements are connected to the generator unit.
4. Attach the RF or power input cable to the connector on the balun box.

MODEL 5503-2M & 5503-3M: LOAD CABLE CONNECTIONS

For both E-mode and H-mode operations, connect the cables from each element to the posts on the load box.

For more information, see *Cables* on page 17.

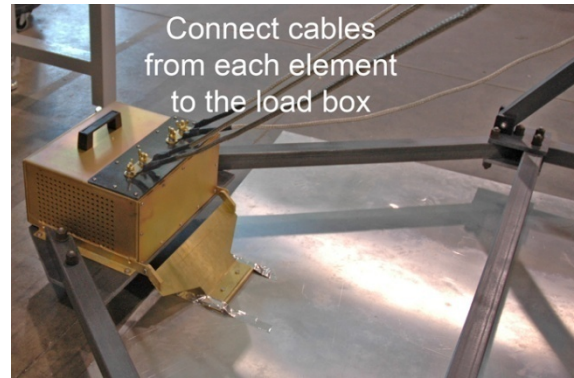

MODEL 5503-2M & 5503-3M: GROUNDING

Before operating the Model 5503-2M or Model 5503-3M, verify that the ground contact foot on the load box and balun box is attached to ground, and is grounded. This can be accomplished by using bolts (not included) that screw onto the ground plane in the shielded room.

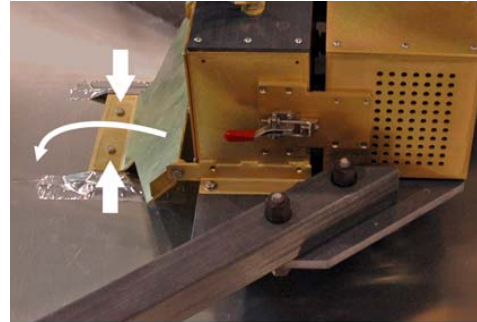

Lower ground contact foot on load and balun boxes

Fasten ground contact foot with bolts to ground plane

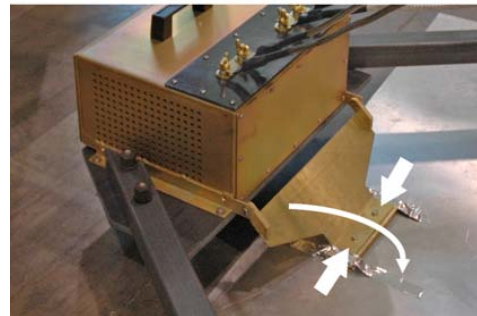

Typical Test Setup

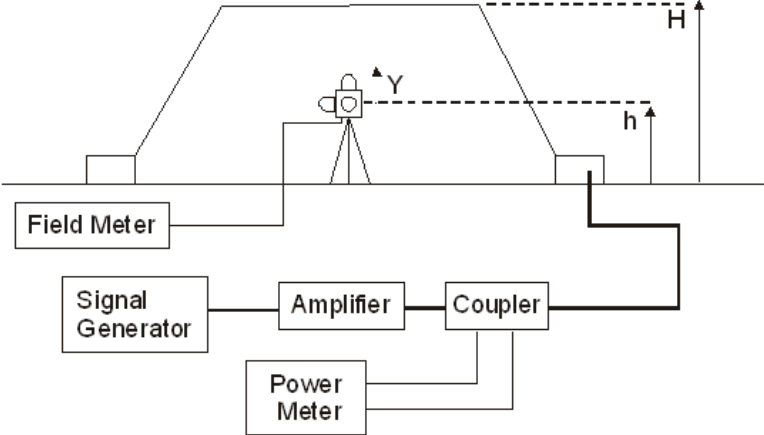

MODEL 5503-5M VSWR

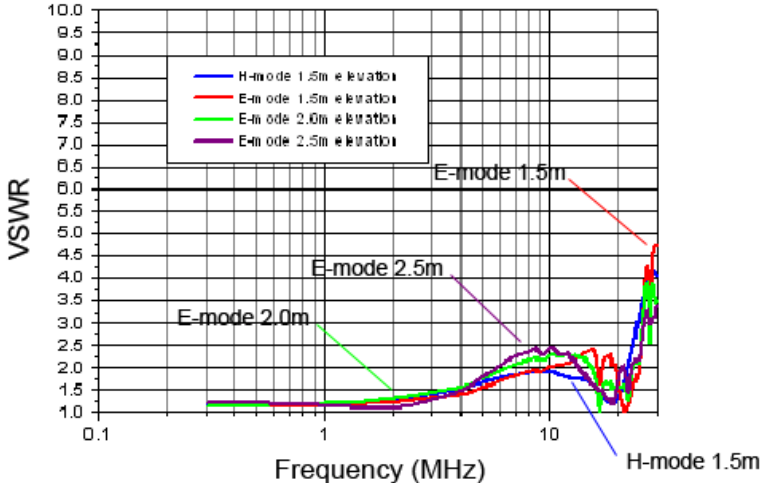

MODEL 5503-5M POWER REQUIREMENTS, 100 V/M

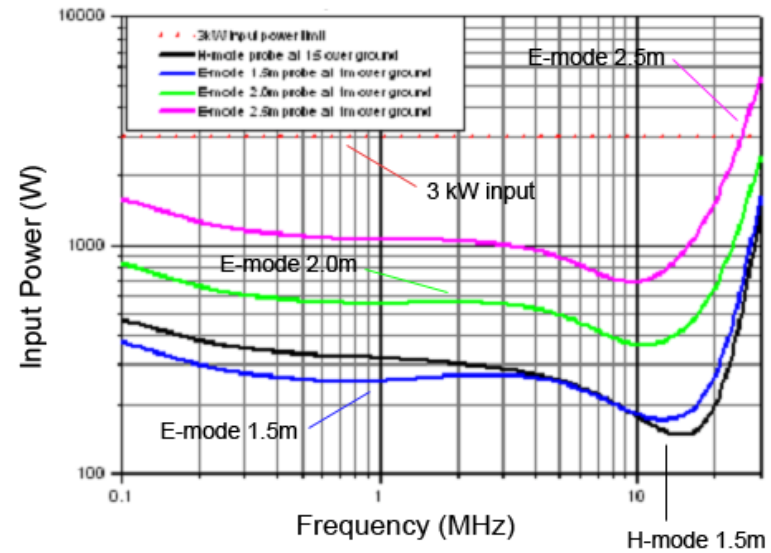

Storage

The Model 5503 provides convenient storage when testing is complete.

1. Disconnect all cables, including those that attach the antenna elements to the load box and balun box.
2. Remove the bolts that connect the elements to the U-shaped brackets.
3. Disconnect the grounding plates.
4. Roll the two sections of the support structure and carry the elements to the storage location.

Appendix A: Warranty



See the *Product Information Bulletin* included with your shipment for the complete ETS-Lindgren warranty for your Model 5503.

DURATION OF WARRANTIES FOR MODEL 5503

All product warranties, except the warranty of title, and all remedies for warranty failures are limited to one year.

Product Warranted	Duration of Warranty Period
Model 5503 Series E&H Field Generator	1 Year

This page intentionally left blank.

Appendix B: Assembly Drawings

Frame Assembly

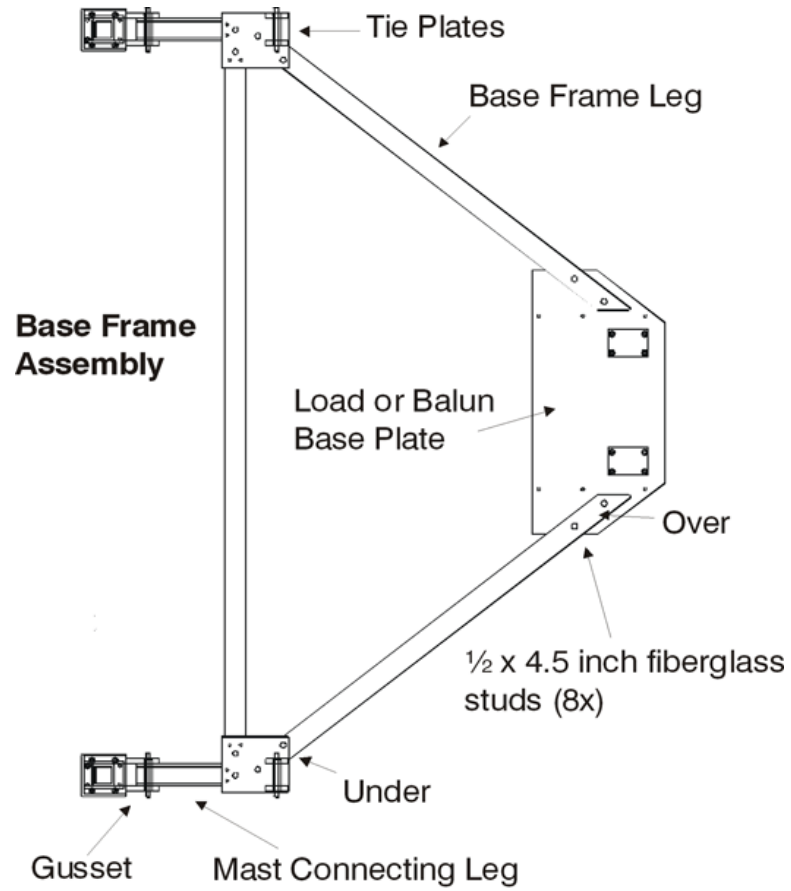

Element Installation

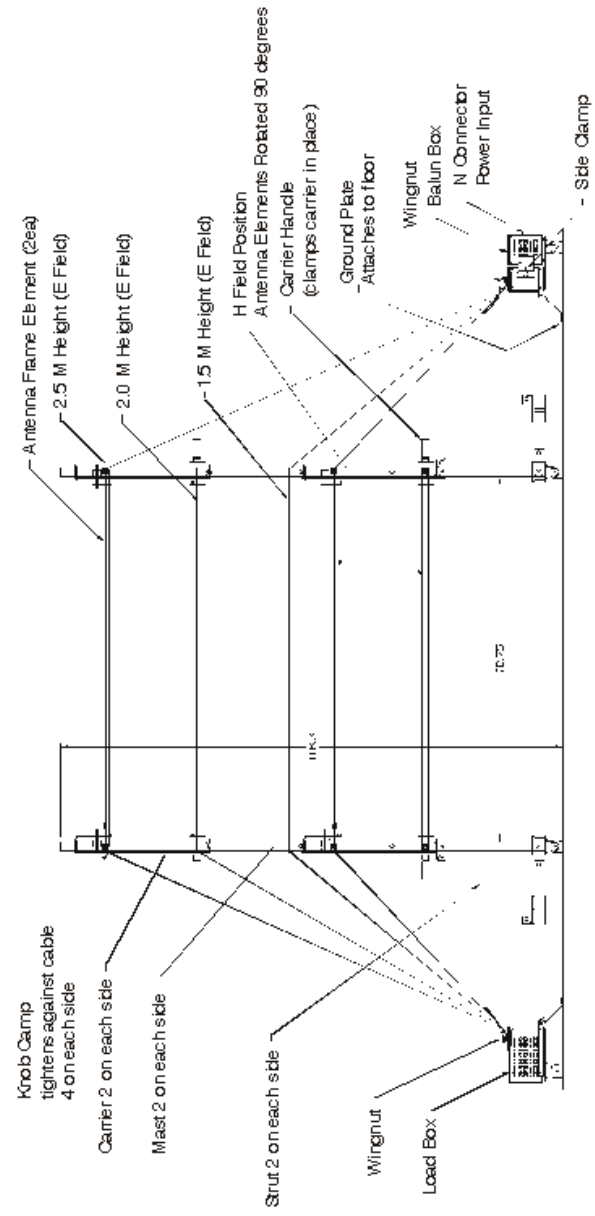

Framing Element (Strut) Installation

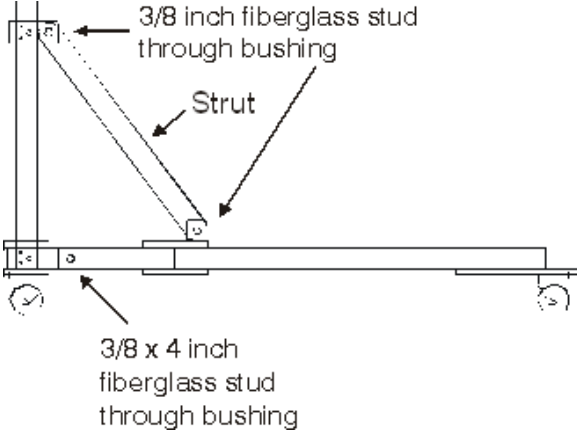

Antenna Orientation

