

**PROFESSIONAL
19" UNIT**

PGT 8



Grundig SAT Systems

**PROFESSIONAL
8
PROFESSIONAL**

CONTENTS

| | |
|-----------|--|
| 3 | General Scope of delivery Available accessories Technical data |
| 4 | At a Glance Components and connectors The control panel |
| 6 | Functional Description The PROFESSIONAL 19" unit PGT 8 |
| 8 | Equipping the 19" Unit Operation with twin LNBS Installing and connecting satellite boxes |
| 9 | Installation into Rack Systems Installation |
| 10 | Operation in Rack Systems Aeration, safety |
| 11 | Accessories GRUNDIG GaAs hybrid amplifier PAMP 4 GRUNDIG professional universal panel PUP 1 GRUNDIG professional remote control unit PRCU 8 GRUNDIG professional satellite control unit PSCU 6000 |
| 14 | Overview of GRUNDIG PROFI Boxes |
| 15 | Connection Example Service (at the end of this user manual) Channel/frequency tables |

GENERAL

Scope of delivery

- 1 PROFESSIONAL 19" unit PGT 8, power supply and control panel included
- 4 Prestole nuts M6
- 4 fixing screws M6 x 16mm with plastic washers
- 1 user manual

Available accessories

- GRUNDIG GaAs hybrid amplifier PAMP 4, order no. GAH4600
- GRUNDIG professional remote control unit PRCU 8, order no. GAH4400
– including the GRUNDIG PC program PRCU
- GRUNDIG professional satellite control unit PSCU 6000, order no. GAH4500
- GRUNDIG professional universal panel PUP 1, order no. GAH7600.

Technical data



This product conforms with the requirements of the 73/23/EC and 89/336/EC guidelines of the European Council. The standards EN 50083-2, EN 50083-2/A1, EN 50083-1 and EN 60065 required for the CE certification are kept to.

| | |
|--|---|
| Plug-in locations (not equipped): | for 8 satellite boxes |
| Input frequency range (SAT IF): | 950–2150 MHz |
| SAT input splitter: | 2 SAT IF inputs A and B with 9 outputs each |
| Passage loss (9-fold): | typ. 16 dB |
| Input impedance: | 75 Ohm |
| Remote LNB power supply: | +18V/total current max.500mA === for <u>both</u> input splitters |
| Output frequency range of RF collector: | 48 MHz ... 865 MHz |
| Output level of the RF collector (depending on box fitted): | about 80 dB μ V |
| Output attenuation of the RF collector: | typ. 18 dB |
| Output impedance: | 75 Ohm |
| Setting range of the RF level controls: | –20 dB |
| Mains voltage: | 220–240 V~; 50/60 Hz |
| Power consumption: | typ. 120 W when fully equipped, LNB power supply included |
| Admissible ambient temperature: | –10 °C to + 50 °C; without humi- dification and dehumidification |
| Dimensions W x H x D: | 482 mm x 356 mm x 254 mm |
| Inner dimensions W x H x D: | 448 mm x 356 mm x 251 mm |
| Weight: | |
| – empty | about 11 kg |
| – fully equipped | about 19 kg |

Important!

The power supply unit of the 19" unit is especially magnetically shielded. When exchanging or replacing the power supply unit, please make sure that it is always installed into the 19" unit with the shielded cover fitted.

AT A GLANCE

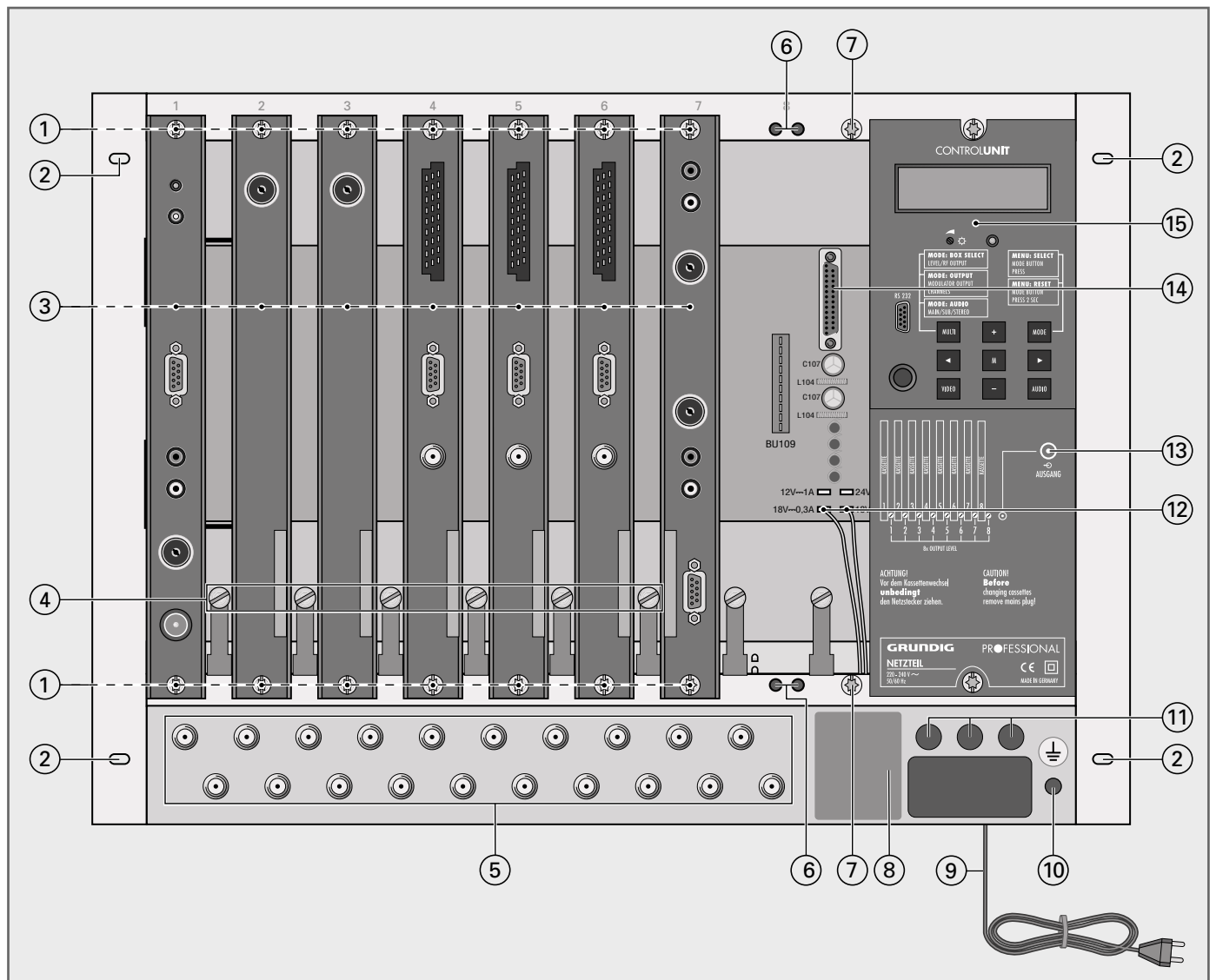
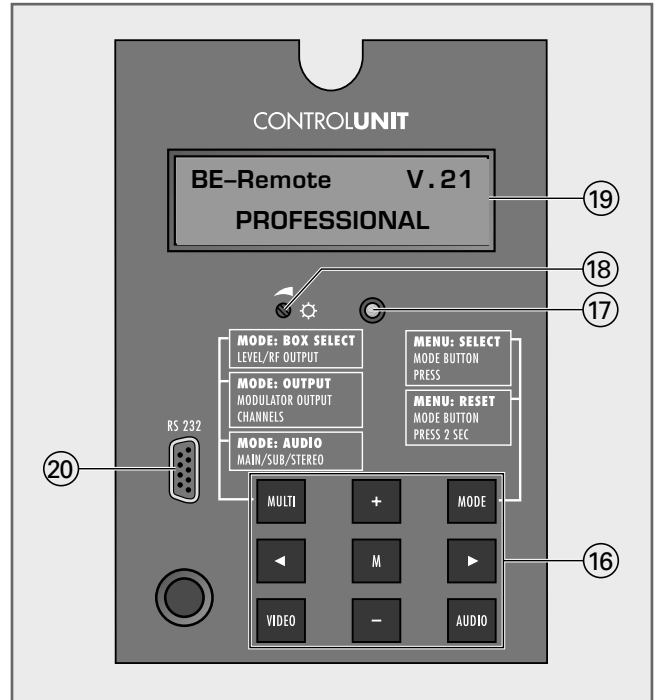
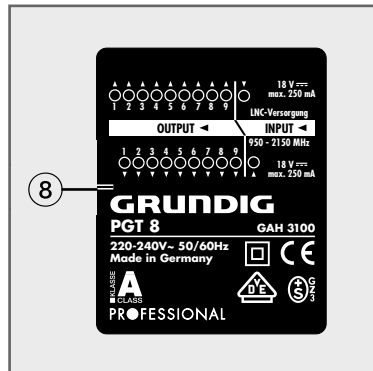

Components and Connectors

- ① Fixing screws for the satellite boxes.
- ② Fixing holes of the 19" unit.
- ③ Plug-in locations for 8 satellite boxes, or for 7 satellite boxes and one professional hybrid amplifier PAMP 4.
- ④ 8 level controls for the satellite boxes' output signal; setting range: 0 dB to -20 dB.
- ⑤ SAT input splitter (F-sockets): 2 inputs **A** and **B**, 9 outputs per input (F-sockets), passage loss: typ. 1.6 dB.
- ⑥ Fixing holes, left, for one satellite box.
Fixing holes, right, for the professional hybrid amplifier PAMP 4.
- ⑦ Two spare screws for the fixation of the satellite boxes.
- ⑧ Type plate with pinning of the input splitter.
- ⑨ Power supply connector; accessible from the bottom.
- ⑩ Opening for a ground terminal: make the ground connection of the unit's frame according to DIN EN 50083/1, VDE 0855, Part 1.
- ⑪ Three openings for feed-through elements, e.g. IEC or F feed-through sleeves.
- ⑫ Two plugs for the LNB supply voltage (+18 V/max. 500 mA ---) for both LNBs.
- ⑬ RF socket of the output collector. This output socket is located on the back of the 19" unit.
- ⑭ 25-pin connector for the connection of a second 19" unit if the two 19" units are to be controlled via one control panel only.
- ⑮ Control panel with illuminated display; behind it the power supply unit.

The control panel

- ⑯ **The buttons on the control panel**
 - » **MULTI** « (multi-function):
In the »OUTPUT« menu: output channel display of the boxes.
In the »AUDIO« menu: display of the main sound carrier and the sound sub-carriers.
 - » **MODE** «:
Select: to next menu item.
Reset: back to access menu.
 - » **VIDEO** «: direct access to the »VIDEO« (video amplitude) menu.
 - » **AUDIO** «: direct access to the »AUDIO« (select audio frequency) menu.
 - » **◀ ▶** « (cursor functions):
select settings; move the cursor in the display (_) to the left or right.
 - » **+ / -** «: change settings.
 - » **M** « (memory): save settings.
- ⑰ LED (orange), illuminated during operation.
- ⑱ Display contrast control.
- ⑲ 2-line LC display, illuminated.
- ⑳ 9-pin Sub-D socket »**RS-232**« (cf. page 7).
Serial interface, input socket for software update.

FUNCTIONAL DESCRIPTION

The PROFESSIONAL 19" unit PGT 8

This 19" unit is the basic unit of a modular system for the reception and conversion of analog satellite broadcasts (radio and TV), digital satellite broadcasts (radio and DVB TV = Digital Video Broadcasting), and terrestrial radio and TV broadcasts.

It is provided for the installation of medium-sized and large broad-band cable systems.

Important!

With this 19" unit, only the signals of GRUNDIG PROFESSIONAL satellite boxes can be processed.

An overview of the PROFIL satellite boxes which can be fitted into this basic unit is to be found on the page 14 of this user manual.

As this 19" unit is a modular system, it is possible to equip it with up to 8 satellite boxes which are fitted into its plug-in locations.

Depending on the satellite boxes fitted, up to 16 analog/digital TV broadcasts, or 16 signals from external audio/video sources, or 32 FM broadcasts can be processed.

After connecting the 19" unit to the mains voltage, all boxes are supplied with the required operating voltages by a switched-mode power supply unit via the plug-in connectors on the contact rail.

The central control panel is connected via I²C bus lines (SDA, SCL) with the boxes.

The passive input splitter provides highest flexibility when selecting signals with horizontal or vertical polarization.

The professional satellite boxes are connected to the two inputs **A** and **B** of the input splitter.

The two inputs can be operated from a remote voltage supply, that is, the LNBs can be supplied with an operating voltage of +18 V and a total current of max. 500mA ---. Each of the two inputs **A** and **B** has nine outputs.

All RF output signals of the boxes are unified in the RF output collector, and then passed on to the RF »**OUTPUT**« socket of the 19" unit. The RF output level of about 80 dB μ V depends on the boxes fitted.

Note:

The RF »**OUTPUT**« socket is located on the back of the 19" unit (see figure opposite).

At the factory, the output level controls of the 19" unit are set to maximum output level for the boxes.

Please adjust the output level of the individual boxes with the associated level controls on the front panel of the 19" unit to the following values:

For analog TV broadcasts to about 70 to 80 dB μ V.

For digital TV broadcasts (64 QAM) about 6 to 10 dB lower than for analog TV broadcasts.

For FM radio broadcasts about 10 dB lower than for analog TV broadcasts.

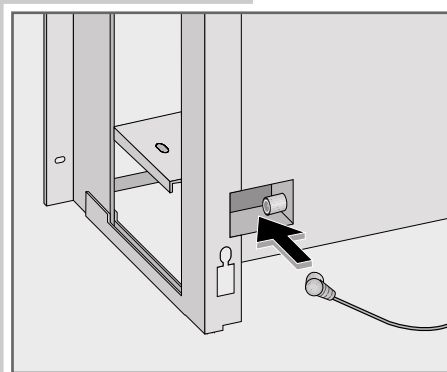
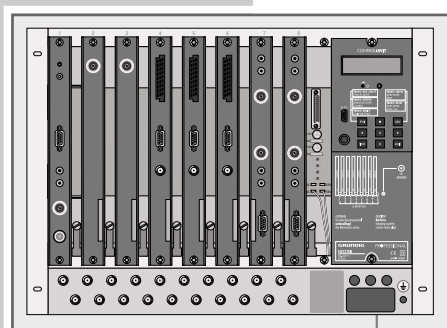

FUNCTIONAL DESCRIPTION

If several professional satellite units are linked with each other, we recommend to install the GRUNDIG GaAs hybrid amplifier PAMP 4 (accessory).

The hybrid amplifier enables an output level of max. 115 dB μ V.

The required operating voltage of +24 V $\overline{\text{---}}$ is provided by the switched-mode power supply unit.

The hybrid amplifier should be installed into that professional satellite unit from which the cable system is supplied.

All input and output parameters of the individual boxes can be selected with the buttons on the control panel.

The user is guided by a two-line illuminated display on the control panel.

When switching the 19" unit on, the software version of the control panel is briefly indicated in the 2-line LC display.

About 5 minutes after the last button is pressed, the display is automatically switched off, or the software version of the control panel is displayed.

Note:

If desired, the software version of the control panel can also manually be displayed in the following way:

Press any two buttons on the control panel of the 19" unit at the same time and hold them down until the following occurs:

- The display turns dark, and then, after several seconds, the software version, e.g. **V.21**, is displayed.

The software version of the GRUNDIG satellite products basic satellite units and satellite boxes can be downloaded from the following Internet address:

<http://www.grundig.de/produkte/sat/mehrt.html>

The 9-pin Sub-D socket »RS-232« is a serial interface for the remote configuration with the help of a PC or notebook and the GRUNDIG remote control unit PRCU 8 (accessory), and for updating the software for the control panel of the 19" unit.

With the help of the GRUNDIG professional satellite control unit PSCU 6000 (accessory), it is possible to monitor the output signal of the broad-band cable system in the frequency range of 47 – 862 MHz.

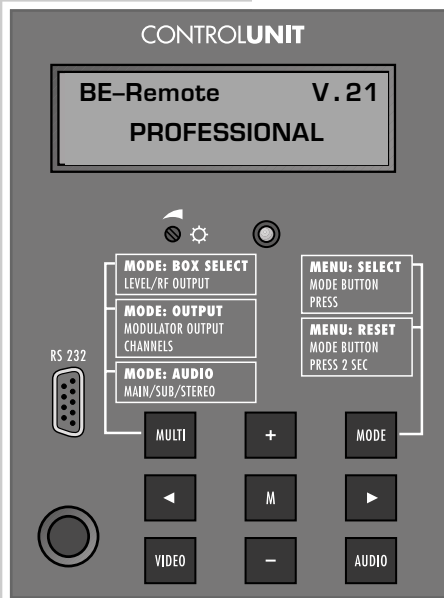

EQUIPPING THE 19" UNIT

Operation with twin LNBS

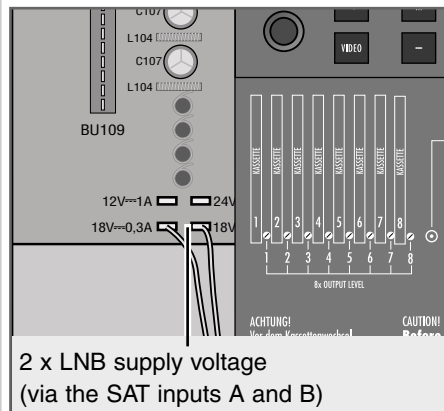

In order to adjust the vertical polarization when twin LNBS are connected, it is necessary to disconnect the voltage supply plug (LNB voltage: +18 V/total current max.500 mA \approx) of the RF input concerned (**A** or **B**) on the chassis board of the 19" unit (see Fig. opposite).

Installing and connecting satellite boxes

Attention!

Before installing or replacing the hybrid amplifier, a professional satellite box, or the power supply unit, it is absolutely necessary to disconnect the power supply plug of the 19" unit from the wall outlet.

The power supply unit of the 19" unit is especially magnetically shielded.

When exchanging or replacing the power supply unit, please make sure that it is always installed into the 19" unit with the shielded cover fitted.

- 1 Install and connect the professional satellite boxes in the 19" unit according to the instructions given in their user manuals.

Note:

If the hybrid amplifier PAMP 4 (accessory) is to be installed instead of a satellite box in the plug-in location 8 of the 19" unit, it is necessary to disassemble beforehand the respective axle carrier with the associated axle for the output level control (see Fig. opposite).

- 2 Install the hybrid amplifier according to the instructions given in its user manual into the 19" unit. When this is done, screw the fixing screws into the right fixing holes in the holding frame. Connect the hybrid amplifier.

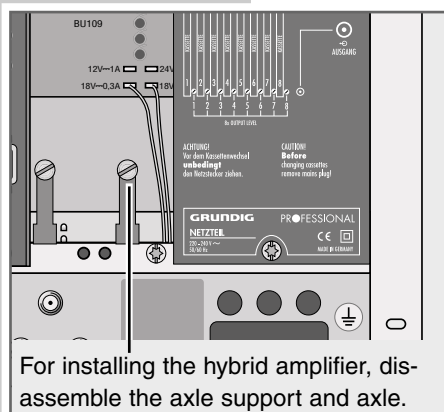

INSTALLATION INTO RACK SYSTEMS

Installation

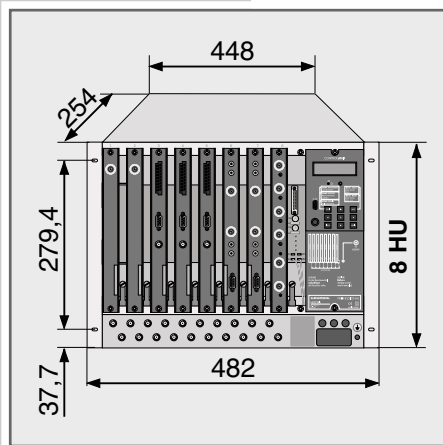

The 19" unit has been designed for installation into 19" rack systems.

Installation material supplied:

- 4 Prestole nuts M 6
- 4 fixing screws M 6 x 16 mm

Precondition:

The rack system is completely assembled, the support elements for placing the 19" unit are already installed.

The total installation height of a 19" unit is 8 HU (= height units, see Fig. opposite). 8 height units correspond to about 356 mm.

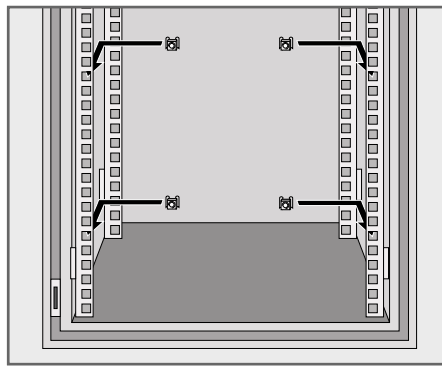

- 1 Fit the four Prestole nuts accurately into the frame of the rack system (see Fig. opposite).

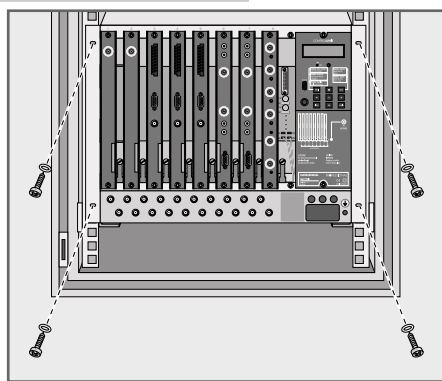

- 2 Insert the 19" unit into the rack system then fix it with the enclosed screws (see Fig. opposite).

Important!

It is absolutely necessary to make sure that the fixation in the rack system is able to carry the high weight of the 19" unit(s).

Before putting the rack system into operation, ground it according to the regulations DIN EN 50083/1, VDE 0855, Part 1.

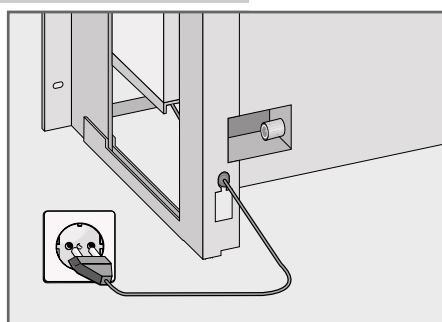

- 3 Connect the mains plug of the 19" unit with a wall outlet (220-240 V~, 50/60 Hz).

Note:

The 19" unit is only completely separated from the mains voltage by pulling the power supply plug.

- 4 Set up the satellite boxes and the hybrid amplifier according to the instructions given in their user manuals.

OPERATION IN RACK SYSTEMS

Aeration, safety

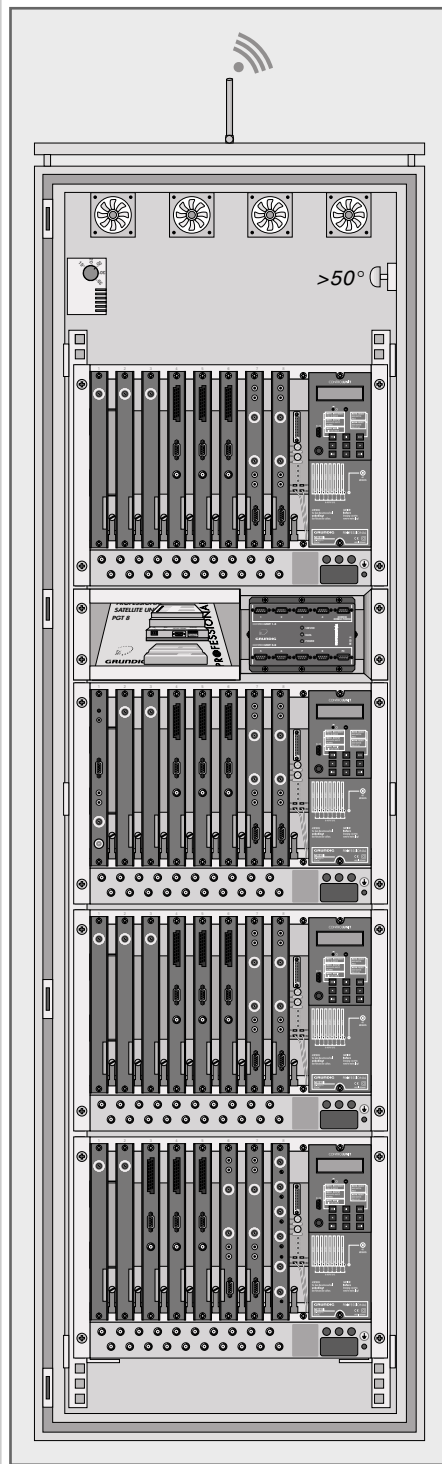

Attention!

When installing the 19" unit into a rack system, it is absolutely necessary to make sure that the ambient and operating temperatures do neither fall below nor exceed the admissible range (-10°C to +50°C) specified by the manufacturer.

When using a GSM modem (e.g. a mobile telephone), the antenna must be installed outside the rack system.

A circular aeration, for example by means of a ventilator, is to be ensured inside the rack system.

In addition, it is necessary to permanently control by means of thermo elements the ambient and operating temperature of max. 50°C specified by the manufacturer.

If the ambient and operating temperature inside the rack system exceeds 50°C max., the thermoswitch of the rack system must automatically disconnect the rack system from the power supply.

Note:

As circuit-breaker at temperatures above 50°C in rack systems, we recommend, for example, the safety temperature limiter with reclose inhibition ATHF-70 of Jumo.

This can be purchased from the RS-Components company under:

- Tel.: ++49 (0) 6105/401 234
- Order number: 357-7935

Never expose the 19" unit to any moisture.

The 19" unit is designed for operation in a dry room.

Always make sure that the 19" unit is not exposed to dripping or splashing water.

Note:

The Figure opposite shows a rack system equipped with four GRUNDIG 19" units PGT 8 and the GRUNDIG professional universal panel PUP 1 (accessory).

ACCESSORIES

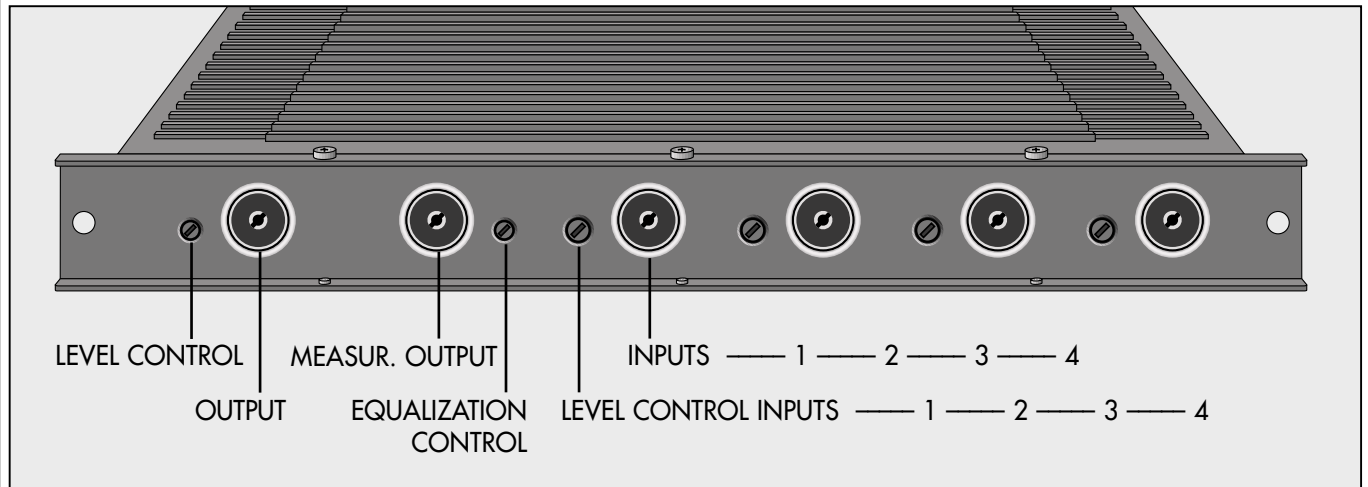

The GRUNDIG GaAs hybrid amplifier PAMP 4

This hybrid amplifier has been designed according to the latest GaAs technology. It comprises 4 Interstage RF inputs, 1 measuring RF output (-30 dB), and 1 RF output.

The level of each of the 4 inputs can be adjusted with the associated level control. In order to compensate the different cable loss over the frequency range of the cable system, the equalization can be adjusted with the associated control.

The output level at the RF output of the hybrid amplifier can be reduced by about -20 dB with the associated control.

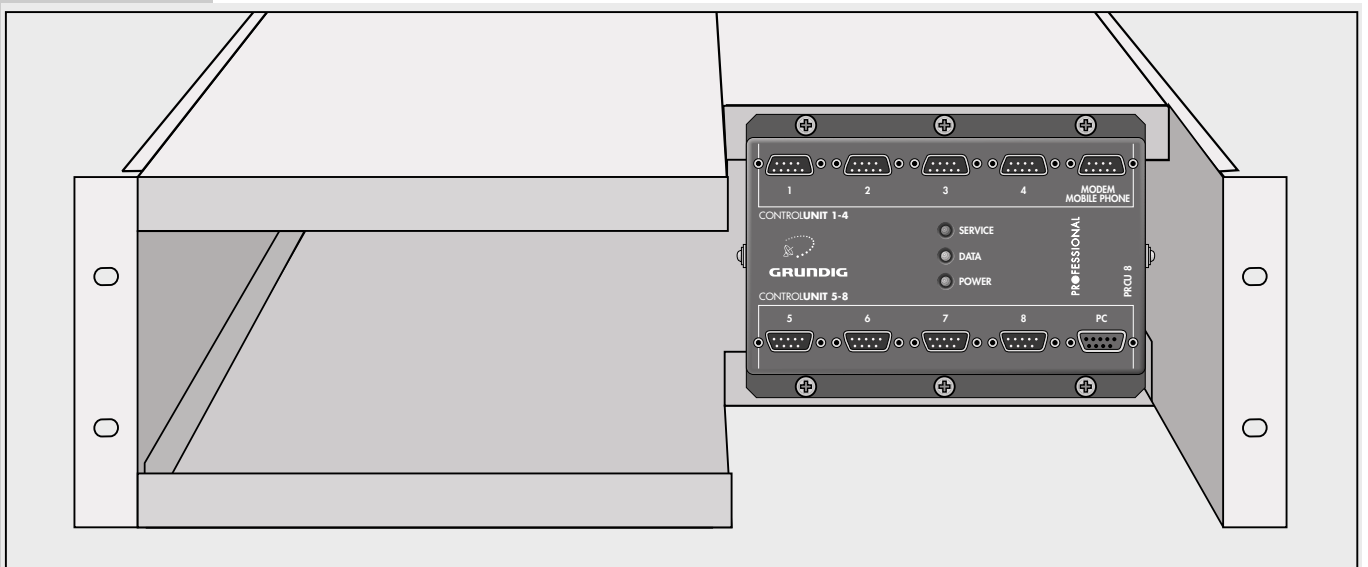

The GRUNDIG professional universal panel PUP1

If you install the GRUNDIG professional universal panel PUP 1 into the rack system, the external accessory, for example the professional remote control unit PRCU 8, can be installed in an easy-to-access place, and all control leads, the modem, the connecting leads, etc. can be kept in a well-ordered way.

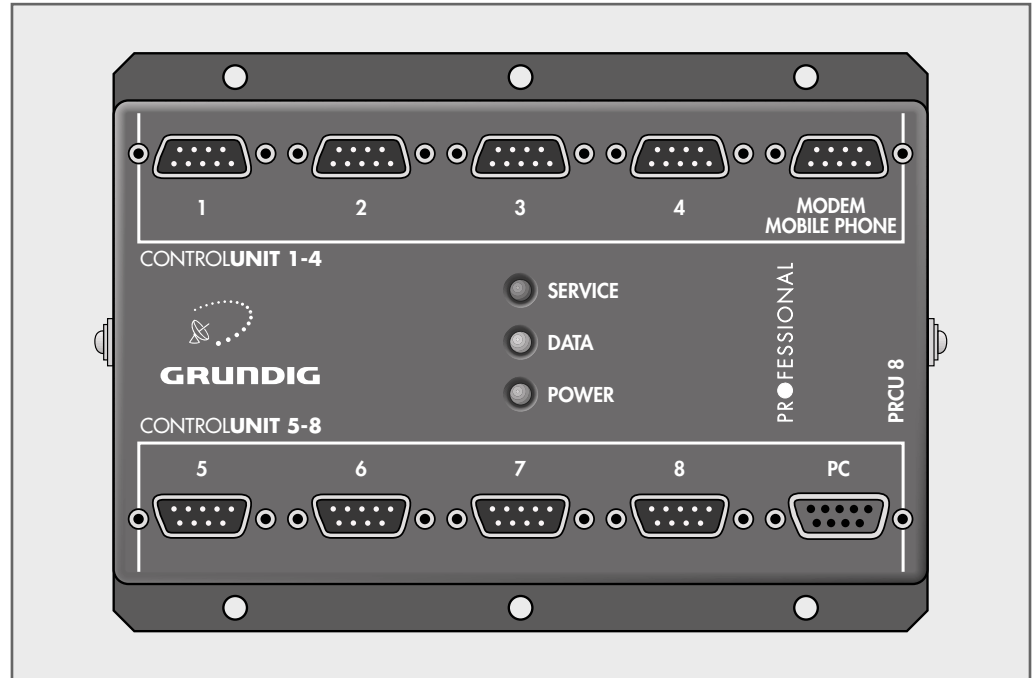

The GRUNDIG remote control unit PRCU 8

It is possible to connect to the GRUNDIG remote control unit PRCU 8 the following equipment:

1 PC or notebook, 1 analogue industry modem or 1 GSM modem (e.g. mobile telephone), 8 basic satellite units, or 7 basic satellite units plus 1 satellite control unit PSCU 6000.

With the help of a PC or notebook along with the remote control unit PRCU 8, the professional satellite control unit PSCU 6000, and the GRUNDIG PC programme PRCU, it is possible to remotely configure and monitor the cable system in a very convenient way.

The PC programme PRCU supplied requires the following system conditions:

- Operating system Windows 95/98/ME/2000/XP.
- Serial interface (Sub-D socket RS-232).

Remote configuration of the cable system

Editing the channel list of the satellite control unit:

- Add new channels.
- Delete existing channels.
- Enter the modulation mode and symbol rate for the manual search.
- Change the channel name.
- Automatic combination of the channel lists of the satellite control unit and of the connected basic satellite units.
- Display of the current RF level of a selected channel.
- Entry of an input attenuation to display the actual RF level of the cable system if the RF input level of the satellite control unit had to be attenuated before.

Remote monitoring of the cable system

- Entry of a minimum or maximum tolerance in dB. If the level exceeds or falls below this tolerance range, an alarm message is transmitted as SMS or Telefax to a layed down telephone number.
- Entry of a waiting time until the alarm message is to be transmitted.
- Monitoring of the activation/deactivation of individual channels.
- Documentation of the entire system with channel lists and setup data of all boxes.

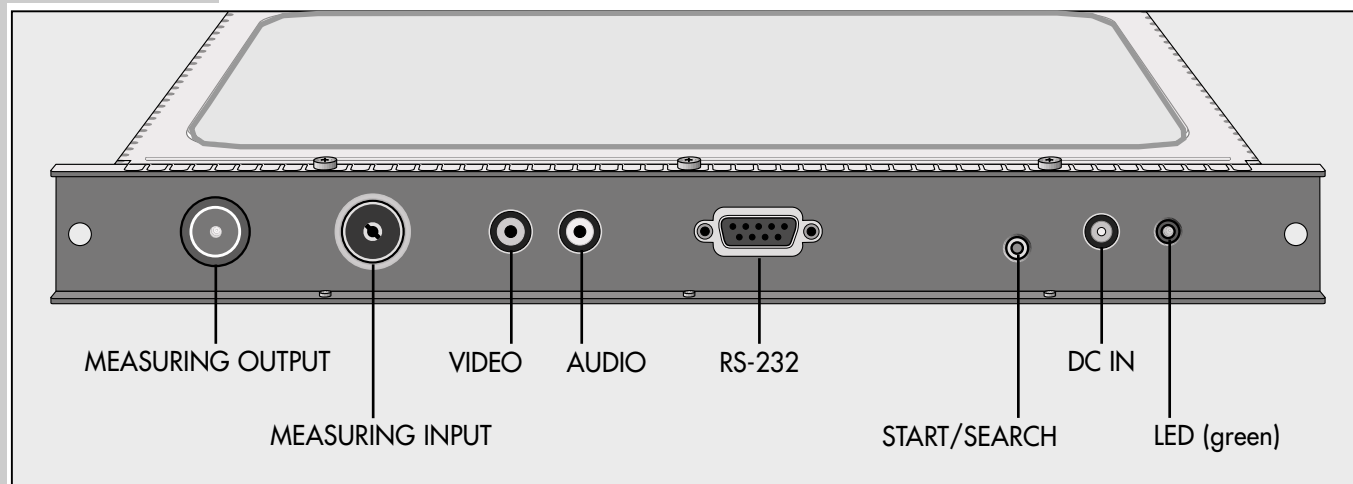

The GRUNDIG satellite control unit PSCU 6000

The professional satellite control unit PSCU 6000 is used for controlling (monitoring) the output signal of a wideband cable system in the frequency range of 47 – 862 MHz.

The following parameters are controlled:

- Analog TV channels: RF level and synchronization pulse.
- Digital TV channels: RF level, BER (Bit Error Rate).
- FM radio programmes: RF level.

The channel search

After starting the channel search, an info channel about the channel assignment of the cable system, including the station names which are determined with the help of the RDS or VPS data, is processed and injected into the cable system.

The channel search starts with the analog TV channels in ascending channel order:

channels C2 ... C4, special channels S2 ... S10, channels C5 ... C12, special channels S11 ... S41, and finally the channels C21 ... C69.

When the search for analog channels is completed, digital TV channels in the frequency range of 306.00 MHz to 858.00 MHz are searched in steps of 8 MHz.

The search finally scans the frequency range of 87.5 MHz to 108 MHz in steps of 50 kHz for FM radio programmes.

With the help of a PC or a notebook, the GRUNDIG professional remote control unit PRCU 8, and the GRUNDIG PC programme PRCU, it is very convenient to set up the configuration of the professional boxes.

OVERVIEW OF PROFI BOXES

Overview of the profi boxes for the 19" unit PGT 8

Programming of the boxes is to be found in the user manual of the box concerned. The following tables list the currently available boxes with the most important data.

Detailed channel/frequency assignments are to be found at the end of this user manual..

| Box type | Input range of the boxes | Output range of the boxes | Channel norm |
|--|---|---|--------------|
| For satellite twin TV reception | | | |
| PSAP 1000 | 950-2150 MHz | Modulator A: C2-C4, Modulator B: S3-S24, C5-C12, 48.25 MHz-327.25 MHz | CCIR |
| PSAP 3000 | 950-2150 MHz | C5-C12, S3-S24 119.25 MHz-327.25 MHz | CCIR |
| PSAP 4000 | 950-2150 MHz | S21-S41 303.25 MHz-463.25 MHz | CCIR |
| PSAP 5000 | 950-2150 MHz | C21-C69 471.25 MHz-855.25 MHz | CCIR |
| For terrestrial twin TV reception | | | |
| PTAP 1000 | C2-C12, S2-S41, C21-C69 | Modulator A: C2-C4, Modulator B: S3-S24, C5-C12, 48.25 MHz-327.25 MHz | CCIR |
| PTAP 3000 | C2-C12, S2-S41, C21-C69 48.25-855.25 MHz | C5-C12, S3-S24 119.25 MHz-327.25 MHz | CCIR |
| PTAP 4000 | C2-C12, S2-S41, C21-C69 48.25-855.25 MHz | S21-S41 303.25 MHz-463.25 MHz | CCIR |
| PTAP 5000 | C2-C12, S2-S41, C21-C69 48.25-855.25 MHz | C21-C69 471.25 MHz-855.25 MHz | CCIR |
| For digital satellite twin reception (QPSK-QAM) | | | |
| PSDQ 4000/4001 | 950-2150 MHz | S21-S41 306.00 MHz-466.00 MHz | QAM/TSM |
| PSDQ 5000/5001 | 950-2150 MHz | C21-C69 474.00 MHz-858.00 MHz | QAM/TSM |
| For digital satellite twin reception (QPSK-PAL) with 1 Common Interface | | | |
| PSDP 1200 | 950-2150 MHz | Modulator A: C2-C4, Modulator B: S3-S24, C5-C12, 48.25 MHz-327.25 MHz | CCIR |
| PSDP 3200 | 950-2150 MHz | C5-C12, S3-S24 119.25 MHz-327.25 MHz | CCIR |
| PSDP 4200 | 950-2150 MHz | S21-S41 303.25 MHz-463.25 MHz | CCIR |
| PSDP 5200 | 950-2150 MHz | C21-C69 471.25 MHz-855.25 MHz | CCIR |
| For FM radio reception | | | |
| PSRF 2000 | 950-2150 MHz | 87.5-108 MHz | FM |
| PTTF 2000 (4-fold FM converter) | UKW 87.5-108 MHz | UKW 87.5-108 MHz | FM |
| PTAF 2000 (FM broadband amplifier) | 87.5-108 MHz | 87.5-108 MHz | FM |

CONNECTION EXAMPLE

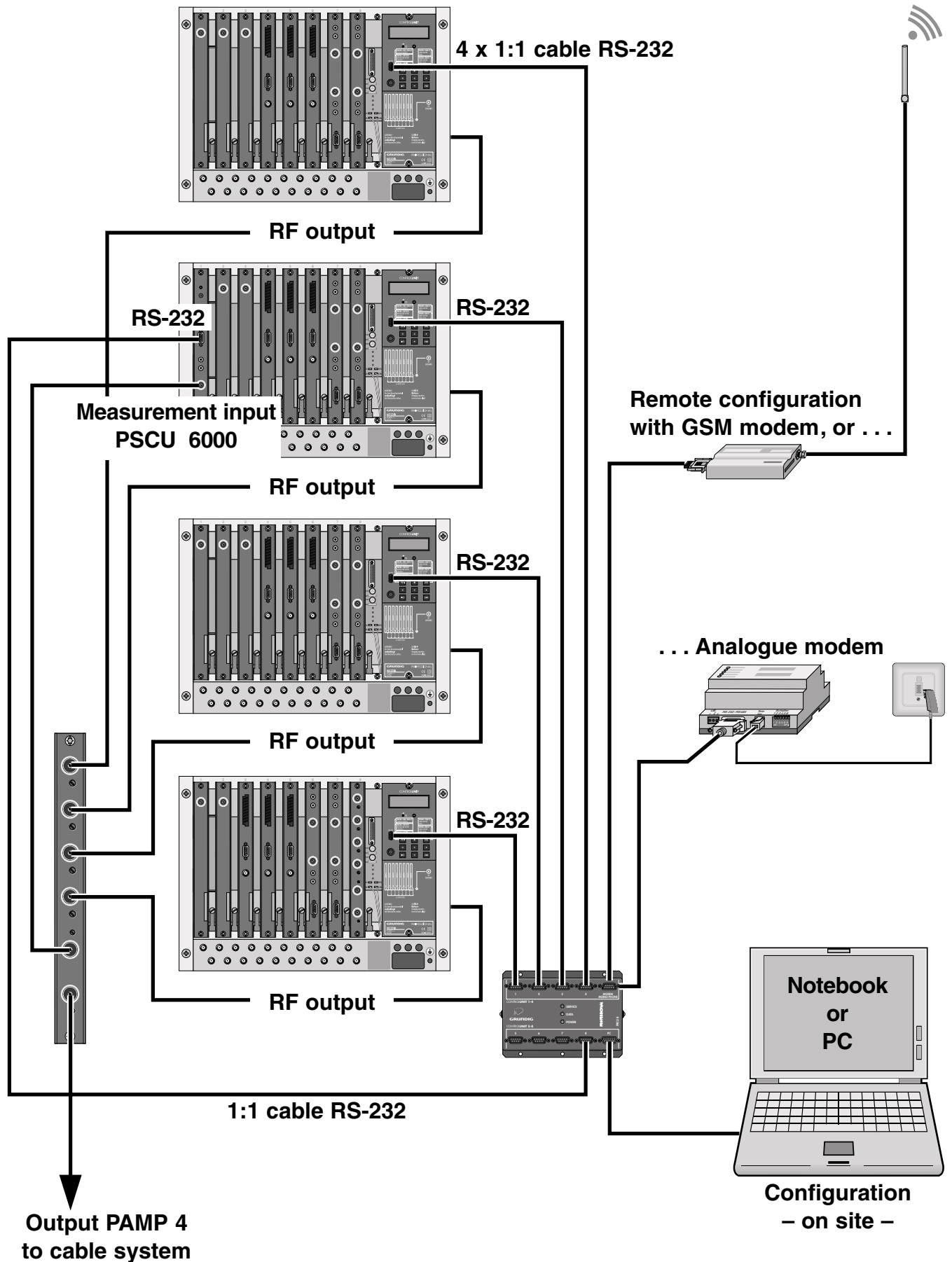

SERVICE

CCIR-Kanalraster/CCIR Channel Steps/Pas de canaux CCIR

Bild-/Ton-Abstand: 5,5 MHz / Video-audio distance: 5.5 MHz / Ecart vidéo/audio: 5,5 MHz

| Kanal | Freq. BT in MHz | Kanal | Freq. BT in MHz | Kanal | Freq. BT in MHz | Kanal | Freq. BT in MHz |
|--------|-----------------|--------|-----------------|--------|-----------------|--------|-----------------|
| Chann. | Frequ. in MHz | Chann. | Frequ. in MHz | Chann. | Frequ. in MHz | Chann. | Frequ. in MHz |
| Canal | Fréqu. en MHz | Canal | Fréqu. en MHz | Canal | Fréqu. en MHz | Canal | Fréqu. en MHz |
| C 2 | 48,25 | S 16 | 266,25 | S 41 | 463,25 | C 45 | 663,25 |
| C 3 | 55,25 | S 17 | 273,25 | C 21 | 471,25 | C 46 | 671,25 |
| C 4 | 62,25 | S 18 | 280,25 | C 22 | 479,25 | C 47 | 679,25 |
| S 2 | 112,25 | S 19 | 287,25 | C 23 | 487,25 | C 48 | 687,25 |
| S 3 | 119,25 | S 20 | 294,25 | C 24 | 495,25 | C 49 | 695,25 |
| S 4 | 126,25 | S 21 | 303,25 | C 25 | 503,25 | C 50 | 703,25 |
| S 5 | 133,25 | S 22 | 311,25 | C 26 | 511,25 | C 51 | 711,25 |
| S 6 | 140,25 | S 23 | 319,25 | C 27 | 519,25 | C 52 | 719,25 |
| S 7 | 147,25 | S 24 | 327,25 | C 28 | 527,25 | C 53 | 727,25 |
| S 8 | 154,25 | S 25 | 335,25 | C 29 | 535,25 | C 54 | 735,25 |
| S 9 | 161,25 | S 26 | 343,25 | C 30 | 543,25 | C 55 | 743,25 |
| S 10 | 168,25 | S 27 | 351,25 | C 31 | 551,25 | C 56 | 751,25 |
| C 5 | 175,25 | S 28 | 359,25 | C 32 | 559,25 | C 57 | 759,25 |
| C 6 | 182,25 | S 29 | 367,25 | C 33 | 567,25 | C 58 | 767,25 |
| C 7 | 189,25 | S 30 | 375,25 | C 34 | 575,25 | C 59 | 775,25 |
| C 8 | 196,25 | S 31 | 383,25 | C 35 | 583,25 | C 60 | 783,25 |
| C 9 | 203,25 | S 32 | 391,25 | C 36 | 591,25 | C 61 | 791,25 |
| C 10 | 210,25 | S 33 | 399,25 | C 37 | 599,25 | C 62 | 799,25 |
| C 11 | 217,25 | S 34 | 407,25 | C 38 | 607,25 | C 63 | 807,25 |
| C 12 | 224,25 | S 35 | 415,25 | C 39 | 615,25 | C 64 | 815,25 |
| S 11 | 231,25 | S 36 | 423,25 | C 40 | 623,25 | C 65 | 823,25 |
| S 12 | 238,25 | S 37 | 431,25 | C 41 | 631,25 | C 66 | 831,25 |
| S 13 | 245,25 | S 38 | 439,25 | C 42 | 639,25 | C 67 | 839,25 |
| S 14 | 252,25 | S 39 | 447,25 | C 43 | 647,25 | C 68 | 847,25 |
| S 15 | 259,25 | S 40 | 455,25 | C 44 | 655,25 | C 69 | 855,25 |

France-Kanalraster/France Chann. Steps/Pas de canaux en France

Bild-/Ton-Abstand: 6,5 MHz / Video-audio distance: 6.5 MHz / Ecart vidéo/audio: 6,5 MHz

| Kanal | Freq. BT in MHz | Kanal | Freq. BT in MHz | Kanal | Freq. BT in MHz | Kanal | Freq. BT in MHz |
|--------|-----------------|--------|-----------------|--------|-----------------|--------|-----------------|
| Chann. | Frequ. in MHz | Chann. | Frequ. in MHz | Chann. | Frequ. in MHz | Chann. | Frequ. in MHz |
| Canal | Fréqu. en MHz | Canal | Fréqu. en MHz | Canal | Fréqu. en MHz | Canal | Fréqu. en MHz |
| C 21 | 471,25 | C 34 | 575,25 | C 47 | 679,25 | C 60 | 783,25 |
| C 22 | 479,25 | C 35 | 583,25 | C 48 | 687,25 | C 61 | 791,25 |
| C 23 | 487,25 | C 36 | 591,25 | C 49 | 695,25 | C 62 | 799,25 |
| C 24 | 495,25 | C 37 | 599,25 | C 50 | 703,25 | C 63 | 807,25 |
| C 25 | 503,25 | C 38 | 607,25 | C 51 | 711,25 | C 64 | 815,25 |
| C 26 | 511,25 | C 39 | 615,25 | C 52 | 719,25 | C 65 | 823,25 |
| C 27 | 519,25 | C 40 | 623,25 | C 53 | 727,25 | C 66 | 831,25 |
| C 28 | 527,25 | C 41 | 631,25 | C 54 | 735,25 | C 67 | 839,25 |
| C 29 | 535,25 | C 42 | 639,25 | C 55 | 743,25 | C 68 | 847,25 |
| C 30 | 543,25 | C 43 | 647,25 | C 56 | 751,25 | C 69 | 855,25 |
| C 31 | 551,25 | C 44 | 655,25 | C 57 | 759,25 | | |
| C 32 | 559,25 | C 45 | 663,25 | C 58 | 767,25 | | |
| C 33 | 567,25 | C 46 | 671,25 | C 59 | 775,25 | | |

SERVICE

OIRT-Kanalraster/OIRT Channel Steps/Pas de canaux OIRT

Bild-/Ton-Abstand: 6,5 MHz / Video-audio distance: 6.5 MHz / Ecart vidéo/audio: 6,5 MHz

| Kanal | Freq. BT in MHz | Kanal | Freq. BT in MHz | Kanal | Freq. BT in MHz | Kanal | Freq. BT in MHz |
|--------|-----------------|--------|-----------------|--------|-----------------|--------|-----------------|
| Chann. | Frequ. in MHz | Chann. | Frequ. in MHz | Chann. | Frequ. in MHz | Chann. | Frequ. in MHz |
| Canal | Fréqu. en MHz | Canal | Fréqu. en MHz | Canal | Fréqu. en MHz | Canal | Fréqu. en MHz |
| R 1 | 49,75 | s 14 | 271,25 | C 21 | 471,25 | C 46 | 671,25 |
| R 2 | 59,25 | s 15 | 279,25 | C 22 | 479,25 | C 47 | 679,25 |
| R 3 | 77,25 | s 16 | 287,25 | C 23 | 487,25 | C 48 | 687,25 |
| R 4 | 85,25 | s 17 | 295,25 | C 24 | 495,25 | C 49 | 695,25 |
| R 5 | 93,25 | s 18 | 303,25 | C 25 | 503,25 | C 50 | 703,25 |
| s 1 | 111,25 | s 19 | 311,25 | C 26 | 511,25 | C 51 | 711,25 |
| s 2 | 119,25 | s 20 | 319,25 | C 27 | 519,25 | C 52 | 719,25 |
| s 3 | 127,25 | s 21 | 327,25 | C 28 | 527,25 | C 53 | 727,25 |
| s 4 | 135,25 | s 22 | 335,25 | C 29 | 535,25 | C 54 | 735,25 |
| s 5 | 143,25 | s 23 | 343,25 | C 30 | 543,25 | C 55 | 743,25 |
| s 6 | 151,25 | s 24 | 351,25 | C 31 | 551,25 | C 56 | 751,25 |
| s 7 | 159,25 | s 25 | 359,25 | C 32 | 559,25 | C 57 | 759,25 |
| s 8 | 167,25 | s 26 | 367,25 | C 33 | 567,25 | C 58 | 767,25 |
| R 6 | 175,25 | s 27 | 375,25 | C 34 | 575,25 | C 59 | 775,25 |
| R 7 | 183,25 | s 28 | 383,25 | C 35 | 583,25 | C 60 | 783,25 |
| R 8 | 191,25 | s 29 | 391,25 | C 36 | 591,25 | C 61 | 791,25 |
| R 9 | 199,25 | s 30 | 399,25 | C 37 | 599,25 | C 62 | 799,25 |
| R 10 | 207,25 | s 31 | 407,25 | C 38 | 607,25 | C 63 | 807,25 |
| R 11 | 215,25 | s 32 | 415,25 | C 39 | 615,25 | C 64 | 815,25 |
| R 12 | 223,25 | s 33 | 423,25 | C 40 | 623,25 | C 65 | 823,25 |
| s 9 | 231,25 | s 34 | 431,25 | C 41 | 631,25 | C 66 | 831,25 |
| s 10 | 239,25 | s 35 | 439,25 | C 42 | 639,25 | C 67 | 839,25 |
| s 11 | 247,25 | s 36 | 447,25 | C 43 | 647,25 | C 68 | 847,25 |
| s 12 | 255,25 | s 37 | 455,25 | C 44 | 655,25 | C 69 | 855,25 |
| s 13 | 263,25 | s 38 | 463,25 | C 45 | 663,25 | | |

GB-Kanalraster/GB Channel Steps/Pas de canaux en GB

Bild-/Ton-Abstand: 6,0 MHz / Video-audio distance: 6.0 MHz / Ecart vidéo/audio: 6,0 MHz

| Kanal | Freq. BT in MHz | Kanal | Freq. BT in MHz | Kanal | Freq. BT in MHz | Kanal | Freq. BT in MHz |
|--------|-----------------|--------|-----------------|--------|-----------------|--------|-----------------|
| Chann. | Frequ. in MHz | Chann. | Frequ. in MHz | Chann. | Frequ. in MHz | Chann. | Frequ. in MHz |
| Canal | Fréqu. en MHz | Canal | Fréqu. en MHz | Canal | Fréqu. en MHz | Canal | Fréqu. en MHz |
| A | 45,75 | C 26 | 511,25 | C 41 | 631,25 | C 56 | 751,25 |
| B | 53,75 | C 27 | 519,25 | C 42 | 639,25 | C 57 | 759,25 |
| C | 61,75 | C 28 | 527,25 | C 43 | 647,25 | C 58 | 767,25 |
| D | 175,25 | C 29 | 535,25 | C 44 | 655,25 | C 59 | 775,25 |
| E | 183,25 | C 30 | 543,25 | C 45 | 663,25 | C 60 | 783,25 |
| F | 191,25 | C 31 | 551,25 | C 46 | 671,25 | C 61 | 791,25 |
| G | 199,25 | C 32 | 559,25 | C 47 | 679,25 | C 62 | 799,25 |
| H | 207,25 | C 33 | 567,25 | C 48 | 687,25 | C 63 | 807,25 |
| I | 215,25 | C 34 | 575,25 | C 49 | 695,25 | C 64 | 815,25 |
| J | 223,25 | C 35 | 583,25 | C 50 | 703,25 | C 65 | 823,25 |
| C 21 | 471,25 | C 36 | 591,25 | C 51 | 711,25 | C 66 | 831,25 |
| C 22 | 479,25 | C 37 | 599,25 | C 52 | 719,25 | C 67 | 839,25 |
| C 23 | 487,25 | C 38 | 607,25 | C 53 | 727,25 | C 68 | 847,25 |
| C 24 | 495,25 | C 39 | 615,25 | C 54 | 735,25 | C 69 | 855,25 |
| C 25 | 503,25 | C 40 | 623,25 | C 55 | 743,25 | | |

SERVICE

China-Kanalraster/China Channel Steps/Pas de canaux en China

Bild-/Ton-Abstand: 6,5 MHz / Video-audio distance: 6.5 MHz / Ecart vidéo/audio: 6,5 MHz

| Kanal Chann. Canal | Freq. BT in MHz Frequ. in MHz Fréqu. en MHz | Kanal Chann. Canal | Freq. BT in MHz Frequ. in MHz Fréqu. en MHz | Kanal Chann. Canal | Freq. BT in MHz Frequ. in MHz Fréqu. en MHz | Kanal Chann. Canal | Freq. BT in MHz Frequ. in MHz Fréqu. en MHz |
|--------------------------|---|--------------------------|---|--------------------------|---|--------------------------|---|
| D 1 | 49,75 | Z 14 | 272,25 | D 13 | 471,25 | D 38 | 711,25 |
| D 2 | 57,75 | Z 15 | 280,25 | D 14 | 479,25 | D 39 | 719,25 |
| D 3 | 65,75 | Z 16 | 288,25 | D 15 | 487,25 | D 40 | 727,25 |
| D 4 | 77,25 | Z 17 | 296,25 | D 16 | 495,25 | D 41 | 735,25 |
| D 5 | 85,25 | Z 18 | 304,25 | D 17 | 503,25 | D 42 | 743,25 |
| Z 1 | 112,25 | Z 19 | 312,25 | D 18 | 511,25 | D 43 | 751,25 |
| Z 2 | 120,25 | Z 20 | 320,25 | D 19 | 519,25 | D 44 | 759,25 |
| Z 3 | 128,25 | Z 21 | 328,25 | D 20 | 527,25 | D 45 | 767,25 |
| Z 4 | 136,25 | Z 22 | 336,25 | D 21 | 535,25 | D 46 | 775,25 |
| Z 5 | 144,25 | Z 23 | 344,25 | D 22 | 543,25 | D 47 | 783,25 |
| Z 6 | 152,25 | Z 24 | 352,25 | D 23 | 551,25 | D 48 | 791,25 |
| Z 7 | 160,25 | Z 25 | 360,25 | D 24 | 559,25 | D 49 | 799,25 |
| D 6 | 168,25 | Z 26 | 368,25 | D 25 | 607,25 | D 50 | 807,25 |
| D 7 | 176,25 | Z 27 | 376,25 | D 26 | 615,25 | D 51 | 815,25 |
| D 8 | 184,25 | Z 28 | 384,25 | D 27 | 623,25 | D 52 | 823,25 |
| D 9 | 192,25 | Z 29 | 392,25 | D 28 | 631,25 | D 53 | 831,25 |
| D 10 | 200,25 | Z 30 | 400,25 | D 29 | 639,25 | D 54 | 839,25 |
| D 11 | 208,25 | Z 31 | 408,25 | D 30 | 647,25 | D 55 | 847,25 |
| D 12 | 216,25 | Z 32 | 416,25 | D 31 | 655,25 | D 56 | 855,25 |
| Z 8 | 224,25 | Z 33 | 424,25 | D 32 | 663,25 | D 57 | 863,25 |
| Z 9 | 232,25 | Z 34 | 432,25 | D 33 | 671,25 | | |
| Z 10 | 240,25 | Z 35 | 440,25 | D 34 | 679,25 | | |
| Z 11 | 248,25 | Z 36 | 448,25 | D 35 | 687,25 | | |
| Z 12 | 256,25 | Z 37 | 456,25 | D 36 | 695,25 | | |
| Z 13 | 264,25 | Z 38 | 464,25 | D 37 | 703,25 | | |

SERVICE

USA-Kanalraster/USA Channel Steps/Pas de canaux en E. U. A.

Bild-/Ton-Abstand: 4,5 MHz / Video-audio distance: 4.5 MHz / Ecart vidéo/audio: 4,5 MHz

| Kanal | Freq. BT in MHz | Kanal | Freq. BT in MHz | Kanal | Freq. BT in MHz | Kanal | Freq. BT in MHz |
|--------|-----------------|--------|-----------------|--------|-----------------|--------|-----------------|
| Chann. | Frequ. in MHz | Chann. | Frequ. in MHz | Chann. | Frequ. in MHz | Chann. | Frequ. in MHz |
| Canal | Fréqu. en MHz | Canal | Fréqu. en MHz | Canal | Fréqu. en MHz | Canal | Fréqu. en MHz |
| c 2 | 55,25 | P | 253,25 | c 33 | 585,25 | c 60 | 747,25 |
| c 3 | 61,25 | Q | 259,25 | c 34 | 591,25 | c 61 | 753,25 |
| c 4 | 67,25 | R | 265,25 | c 35 | 597,25 | c 62 | 759,25 |
| c 5 | 77,25 | S | 271,25 | c 36 | 603,25 | c 63 | 765,25 |
| c 6 | 83,25 | T | 277,25 | c 37 | 609,25 | c 64 | 771,25 |
| A | 121,25 | U | 283,25 | c 38 | 615,25 | c 65 | 777,25 |
| B | 127,25 | V | 289,25 | c 39 | 621,25 | c 66 | 783,25 |
| C | 133,25 | W | 295,25 | c 40 | 627,25 | c 67 | 789,25 |
| D | 139,25 | c 14 | 471,25 | c 41 | 633,25 | c 68 | 795,25 |
| E | 145,25 | c 15 | 477,25 | c 42 | 639,25 | c 69 | 801,25 |
| F | 151,25 | c 16 | 483,25 | c 43 | 645,25 | c 70 | 807,25 |
| G | 157,25 | c 17 | 489,25 | c 44 | 651,25 | c 71 | 813,25 |
| H | 163,25 | c 18 | 495,25 | c 45 | 657,25 | c 72 | 819,25 |
| I | 169,25 | c 19 | 501,25 | c 46 | 663,25 | c 73 | 825,25 |
| c 7 | 175,25 | c 20 | 507,25 | c 47 | 669,25 | c 74 | 831,25 |
| c 8 | 181,25 | c 21 | 513,25 | c 48 | 675,25 | c 75 | 837,25 |
| c 9 | 187,25 | c 22 | 519,25 | c 49 | 681,25 | c 76 | 843,25 |
| c 10 | 193,25 | c 23 | 525,25 | c 50 | 687,25 | c 77 | 849,25 |
| c 11 | 199,25 | c 24 | 531,25 | c 51 | 693,25 | c 78 | 855,25 |
| c 12 | 205,25 | c 25 | 537,25 | c 52 | 699,25 | c 79 | 861,25 |
| c 13 | 211,25 | c 26 | 543,25 | c 53 | 705,25 | c 80 | 867,25 |
| J | 217,25 | c 27 | 549,25 | c 54 | 711,25 | c 81 | 873,25 |
| K | 223,25 | c 28 | 555,25 | c 55 | 717,25 | c 82 | 879,25 |
| L | 229,25 | c 29 | 561,25 | c 56 | 723,25 | c 83 | 885,25 |
| M | 235,25 | c 30 | 567,25 | c 57 | 729,25 | | |
| N | 241,25 | c 31 | 573,25 | c 58 | 735,25 | | |
| O | 247,25 | c 32 | 579,25 | c 59 | 741,25 | | |

