



Loving music

Upgrade Innovation to Master Innovation

User manual Upgrade Innovation to Master Innovation

Innovation Wood



Innovation Wood
with
clearaudio tonearm „Universal“ and
clearaudio cartridge „da Vinci“.

Master Innovation Wood

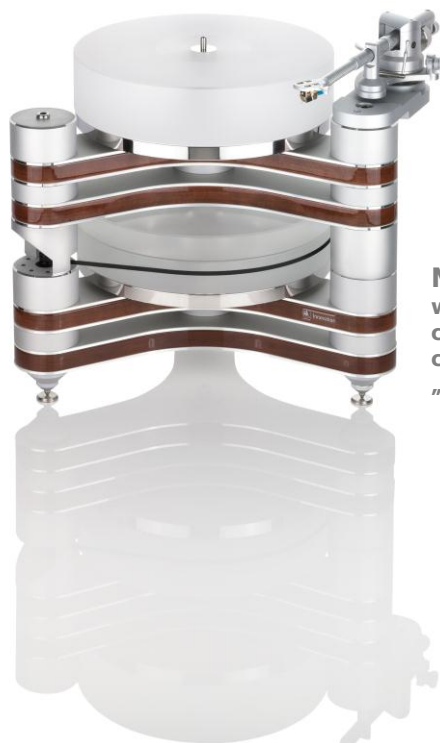

Master Innovation Wood
with:
clearaudio tonearm „Universal“ and
clearaudio cartridge
„Goldfinger Statement“.

Made in Germany

Hi-Fi Components **clearaudio electronic[®]** GmbH

Spardorfer Str. 150 • D-91054 Erlangen • Tel. +49 9131/40 300 100 • FAX +49 9131/40 300 119
www.clearaudio.de • www.analogshop.de • info@clearaudio.de • copyright clearaudio© 2014



Upgrade *Innovation to Master Innovation*

User manual

Dear **clearaudio** customer,

Congratulations to your choice to upgrade your *Innovation* to a *Master Innovation* turntable, a world class turntable, handmade in Germany by **clearaudio** electronic GmbH.

Like the model *Innovation* the *Master Innovation* has a resonance minimizing chassis construction in a sandwich combination with the innovative motor unit (low noise level and high turning moments), which guarantees total isolation of resonances from the turntable chassis, providing the best music reproduction and authentic High End imaging.

The **clearaudio** patented CMB-Bearing-Technology, an inverted bearing with jewelled and polished ceramic bearing shaft and a bronzed liner, provides frictionless analogue enjoyment.

This user manual described the reconstruction from the turntable *Innovation* to the turntable *Master Innovation*. For more information regarding the *Master Innovation* you will get a separate user manual.

We wish you a lot of musical enjoyments with your new **clearaudio** *Master Innovation*-turntable.

clearaudio electronic GmbH

This section must be read before any connection is made to the mains supply.

WARNINGS

Don't expose your turntable to rain or humidity.
Don't handle the mains leads with wet hands.
Don't place or insert anything into the equipment or through ventilation holes.
No naked flame sources, such as lighted candles, should be placed on the equipment.

CE-MARKING

CE The **clearaudio** *Master Innovation* meets the regulations concerning electromagnetic disturbance (EMC) and low-voltage appliances.

EQUIPMENT MAINS WORKING SETTING

Your clearaudio product has been prepared to comply with the household power and safety requirements that exist in your area. This product can be connected to 230 V or 110 V AC (50 Hz and 60 Hz).

COPYRIGHT

Recording und reproduction of any sound-material may require the consent of the creator. Please acknowledge the information given in the

- Copyright Act 1956,
- Dramatic and Musical Performers Act 1958,
- Performers Protection Acts 1963 and 1072,
- any more recent legal regulations.

Contents

1. Packing overview	3
2. Part list	4
3. Reconstruction <i>Innovation to Master Innovation</i>	6
4. Fine adjustment of the motor	15
5. Service and special instructions	16
6. Technical data	17
Warranty – information	18

1. Packing overview

Box 1 of 2:

Drive unit,
already pre – mounted at
factory;
accessories

Box 2 of 2:

Stainless steel platter,
drive platter (38 mm)

2. Part list

Clearaudio has developed a special and secure packing for your *Master Innovation* turntable that ensures a safe transportation.

Please keep this original packing, if you need to ship the turntable.
Below you find the part list of the **clearaudio** *Master Innovation* turntable:

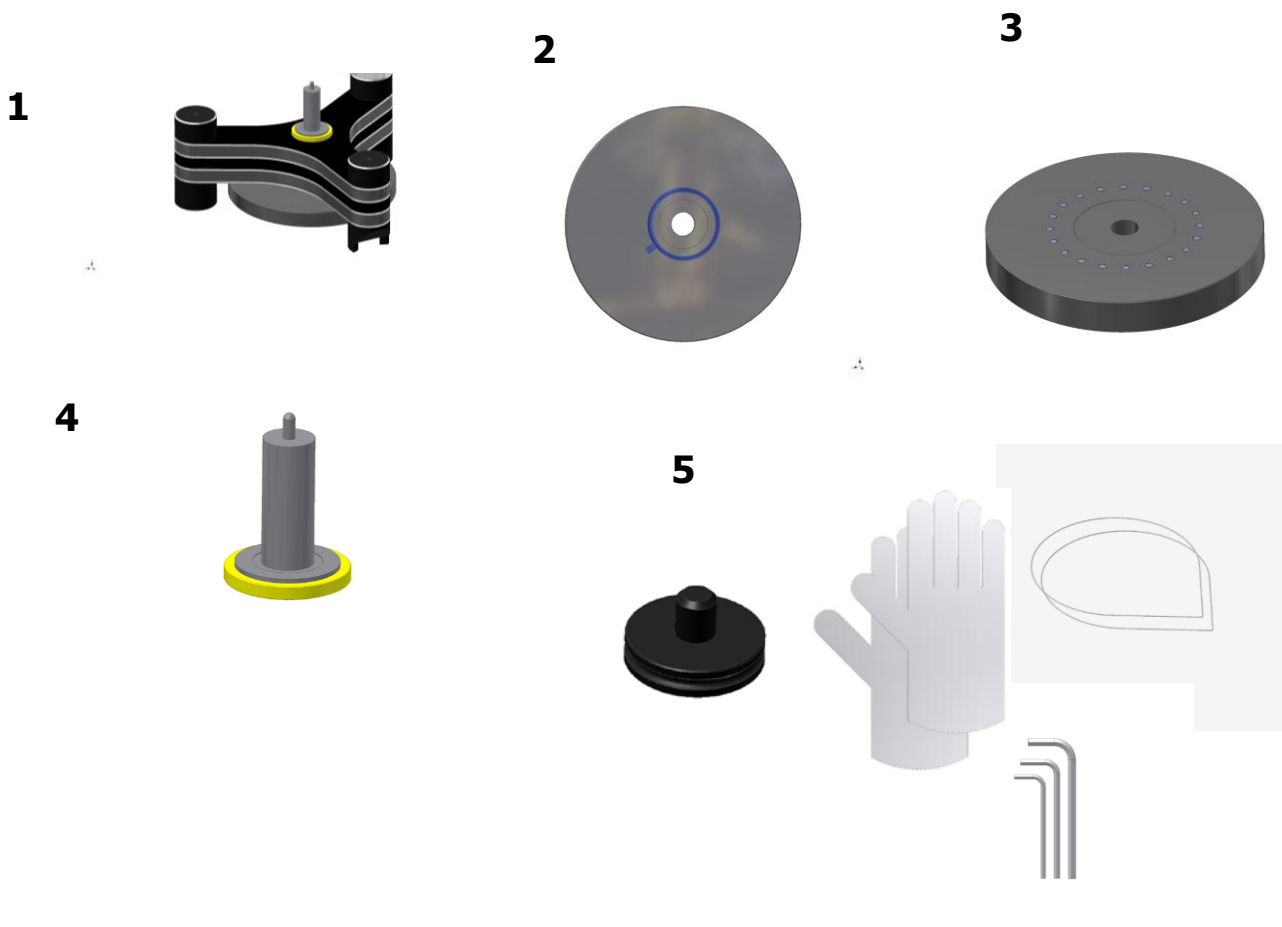

1.	First drive unit, pre-mounted (Box 1 of 2)	2.	Stainless steel sub-platter (Box 2 of 2)
3.	Platter with magnets (38 mm) (Box 2 of 2)	4.	Drive bearing
5.	Accessories: Pulley, white gloves, 2 x drive belts, allen wrench (# 8), bearing oil, user manual, QCQ – Card, warranty card		

3. Reconstruction *Innovation to Master Innovation*

The reconstruction of the turntable *Innovation* to Master Innovation is easy as most parts of the turntable chassis are already pre-assembled and has been tested at the factory.

Please use the enclosed white gloves in order to avoid scratches or unwanted fingerprints on the turntable parts or platters.

After the reconstruction the *Master Innovation* turntable requires a space for set-up of at least (in inch): 18.9 x 19.3.

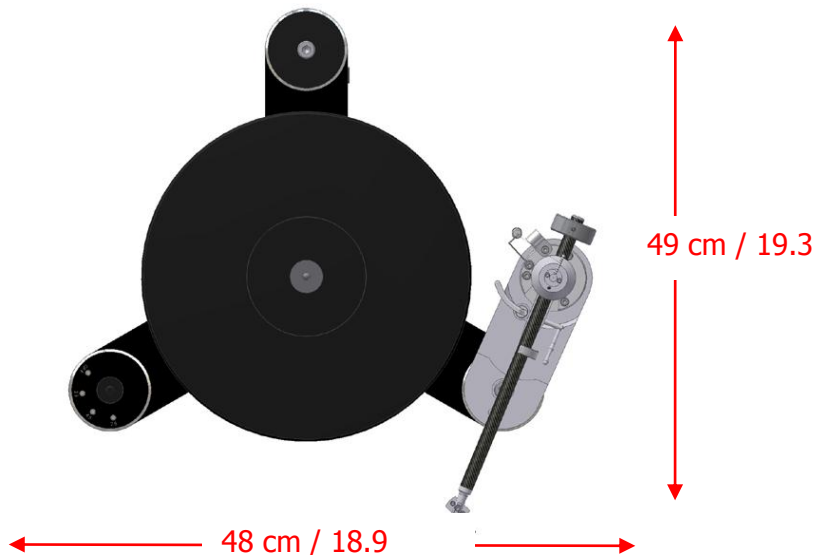

Pic. 1: Required set - up space (with clearaudio tonearm Unify)

Before you can start to reconstruct the *Innovation* turntable to the *Master Innovation* please pay attention that **all bases of the *Innovation* turntable have the height of 40 mm!** If one of your bases has not the height of 40 mm, please contact the dealer, where you have purchased your *Innovation* turntable.

1.)

Take off the tonearm base and the blind screw on the other base at your *Innovation* turntable (as shown in pic. 2).

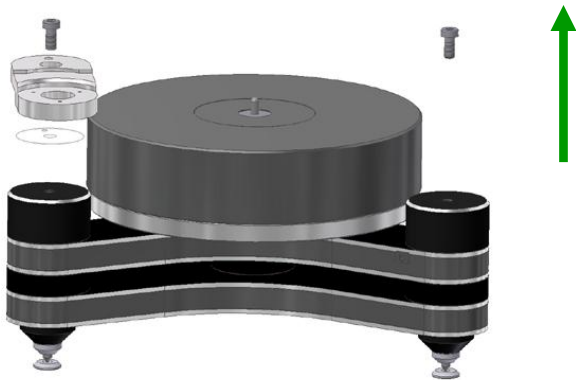

Pic. 2: *Innovation* turntable backside.

2.)

In the next step take off carefully the drive platter of your *Innovation*. Please keep all platters with you, as you need the platters again for the upgrade to the *Master Innovation*.

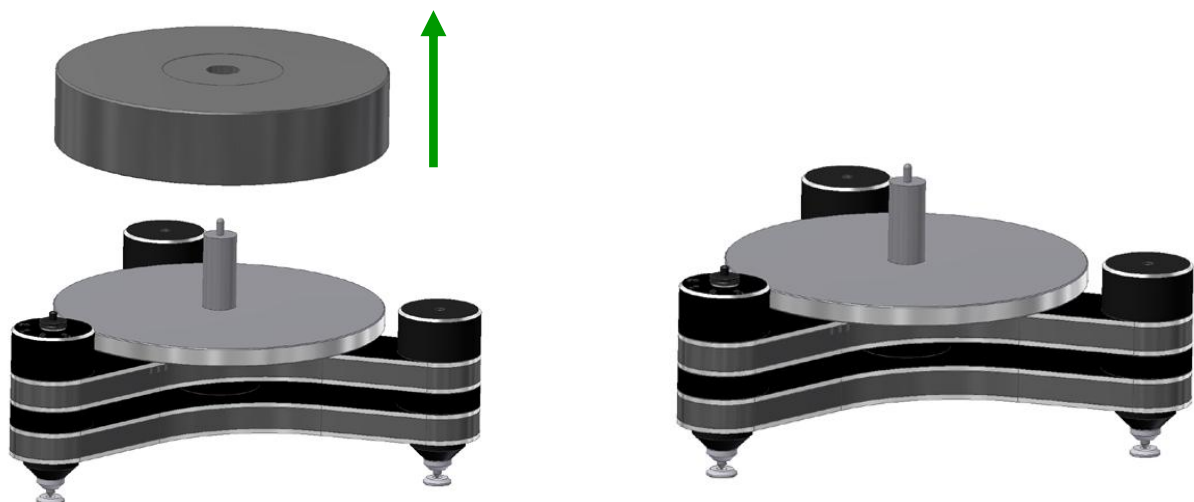

Pic. 3: Taking off the drive platter

3.)

Now remove carefully the stainless steel platter with the mounting clip (accessory of *Innovation* turntable).

Avoid major side forces to avoid any damages to the ceramic bearing!

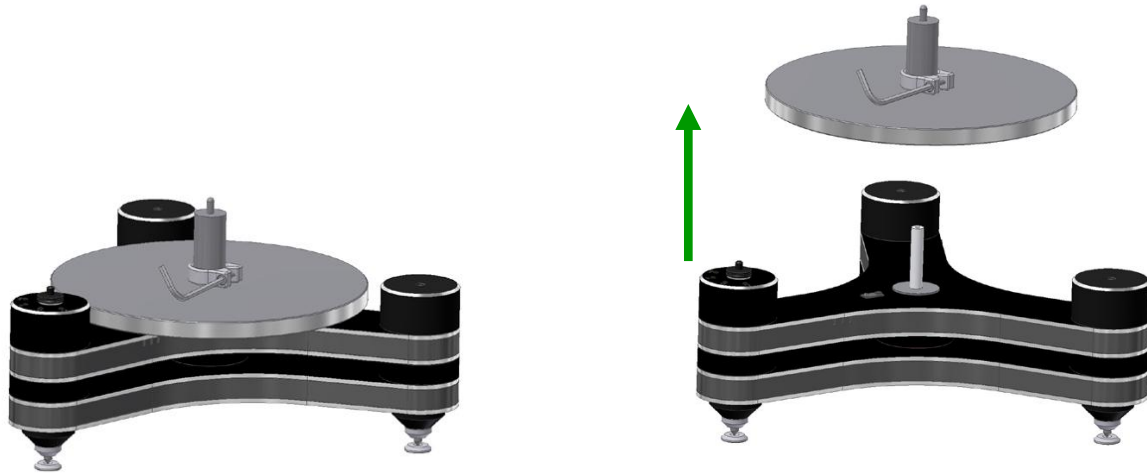

Pic. 4: Taking off the stainless steel platter

4.)

Next please remove the bearing of your *Innovation*. For that unscrew carefully the screw on the lower side of the turntable and pull the bearing out of the chassis.

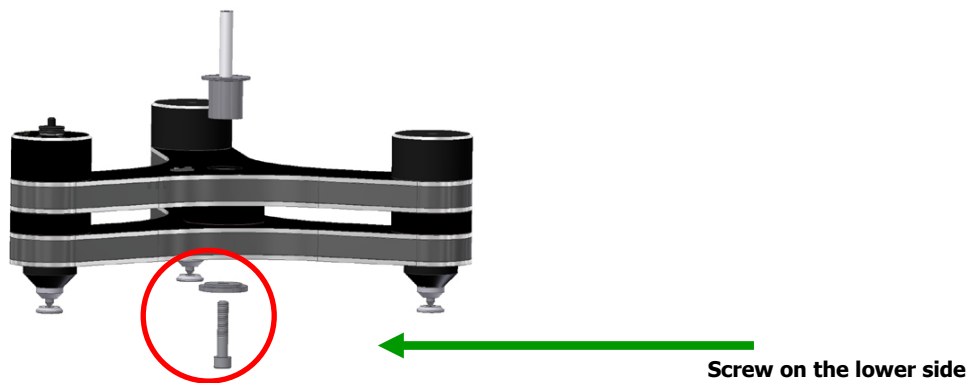

Pic. 5: Removing the bearing

5.)

Take out the delivered drive bearing for the *Master Innovation*. Please remove carefully any protective security tape from the bearing. Now you can put the new bearing into the chassis (see pic. 6) and arm the bearing with the delivered screw on the lower side of the turntable.



Pic. 6: Set – up of the drive bearing

6.)

Now please exchange the pulley of the *Innovation* turntable with the delivered pulley.

Pulley *Innovation*

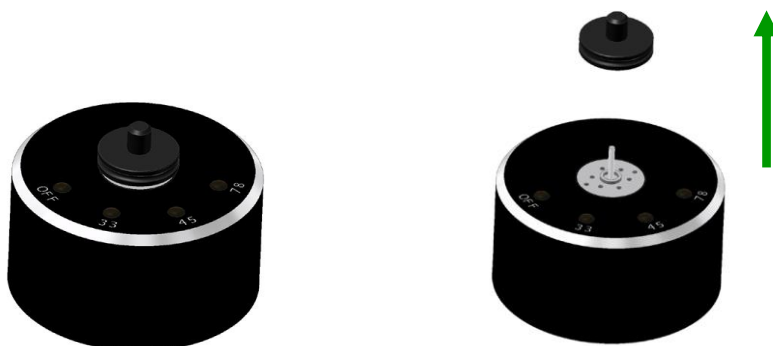

Pic. 7: Exchange of the pulleys.

Please pay attention that the exchanged *Master Innovation* pulley is flush mounted with the axis of the motor.

Pulley for *Master Innovation*



Pic. 7: Set – up of the *Master Innovation* pulley

Now the upgrade from the *Innovation* to the *Master Innovation* is completed and you can switch over to the set – up of the *Master Innovation*.

In the user manual for the *Master Innovation* you will find the packing – list, packing overview and of course the whole description for the set – up of the *Master Innovation*.

To make it easier for you, you can also go ahead with the following description:

7.)

In the next step remove carefully the lamination of the sensor on the upper surface of the turntable chassis.

Please remove the lamination extreme carefully and avoid any soiling and scratches.

Take the stainless steel sub - platter again carefully with both hands and put it onto the bearing. The lower side must show to the bearing.

Through a lightly (!!) up and down movement the platter will slip onto the bearing upper part (pic. 8 and 9).

Please remove the lamination extreme carefully and avoid any soiling and scratches.



Pic. 8: Set – up of the sub - platter

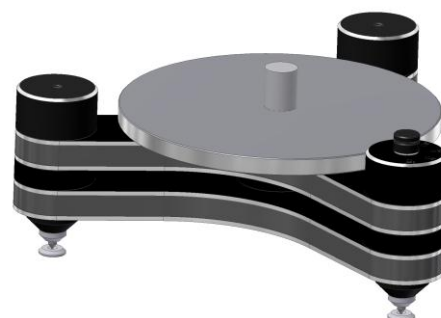

Pic. 9: Set – up of the sub - platter

8.)

Take the drive - platter with both hands carefully out of the box and remove the protection sheet.

Please pay attention that the magnets on the upper surface of the drive – platter must be faced upwards.

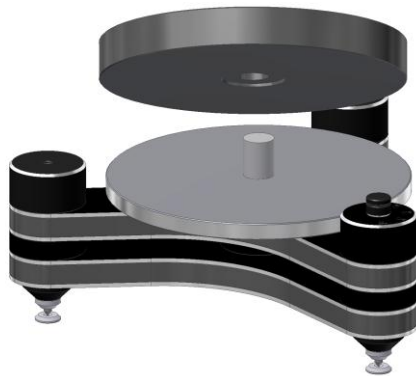

Magnets (face upwards)

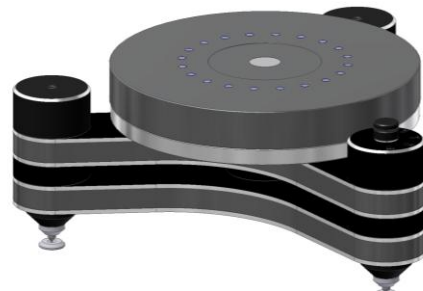

Pic. 10: Set – up of the drive - platter

9.)

Throw one of the delivered drive belt at the drive – platter and the pulley.
Please pay attention that the drive belt is not twisted.

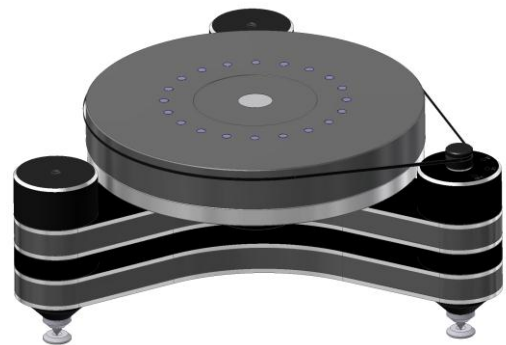
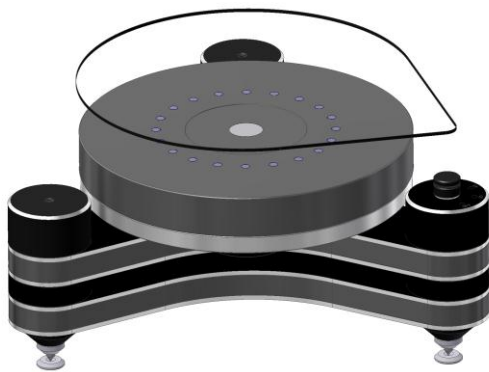

Pic.11: Set – up of the drive belt

10.)

Now take carefully the turntable unit out of the box 2 und set it onto the drive unit as shown in the picture below (pic.12)

Please pay attention that the **protection sheet between both units still remain** to avoid any damages!

Please pay attention that **all center pins must be set very carefully into all threaded holes.**

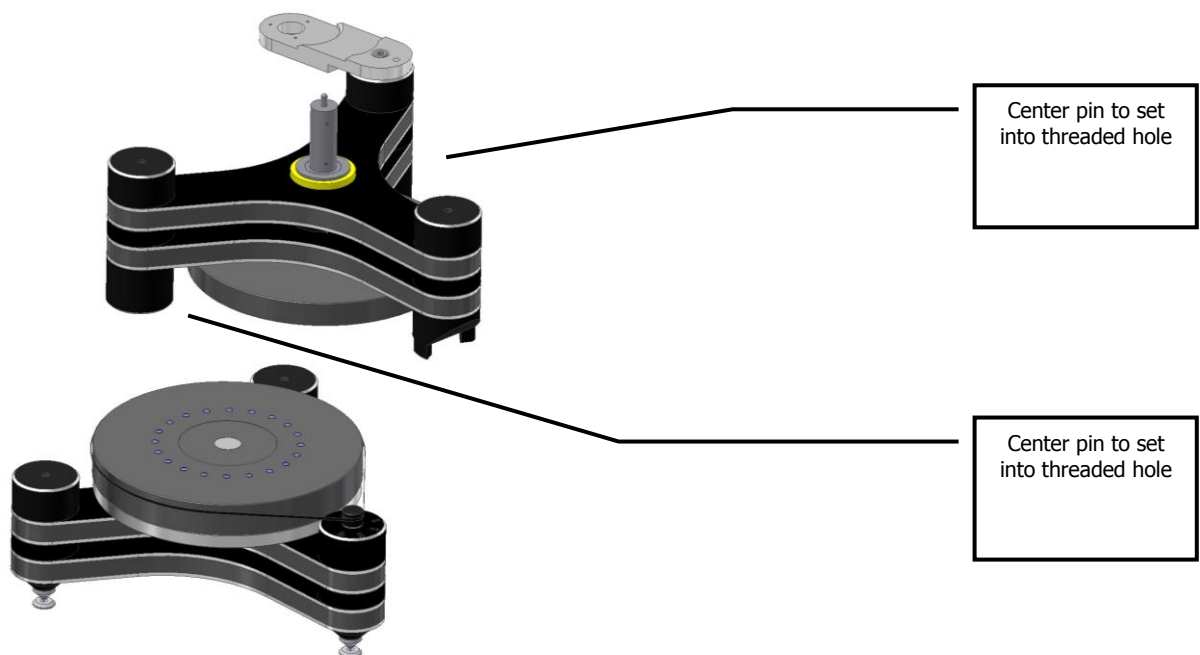

Pic. 12: Set – up of the turntable unit

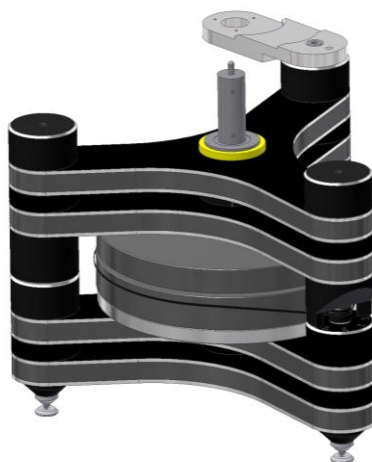

Pic 13.: Finished set – up of the turntable unit

11.)

Take the stainless – steel sub – platter out of the box 3 and remove only the protection sheet, but keep the protection film of the upper side of the sub – platter.

Put the sub – platter very carefully onto the upper part of the bearing (pic. 14a)

Now take the main platter out of the box and set it up onto the upper part of the bearing. The recess for the label must be faced upwards. Now you can carefully remove the protection film (pic. 14b).

To avoid any damages on your bearing, the Delrin-platter should have room temperature before the set up begin (approx. 20 ° Celsius).

Avoid major side forces to avoid any damages to the ceramic bearing!

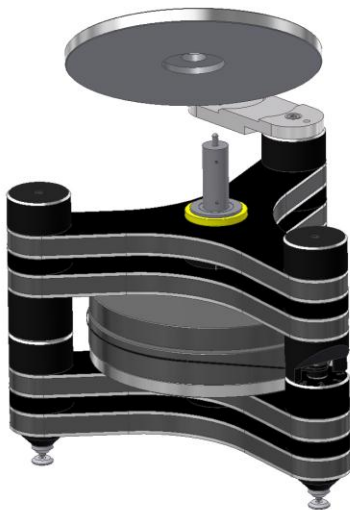

Pic. 14a: Set – up of the stainless steel sub - platter

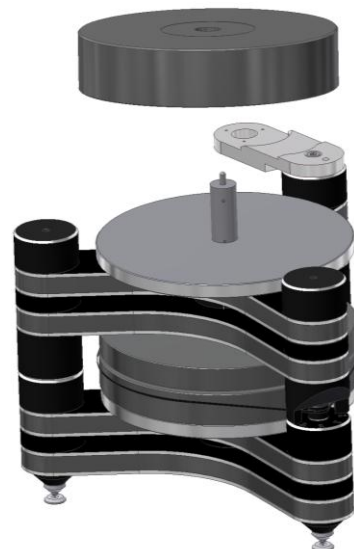

Pic. 14b: Set – up of the main platter

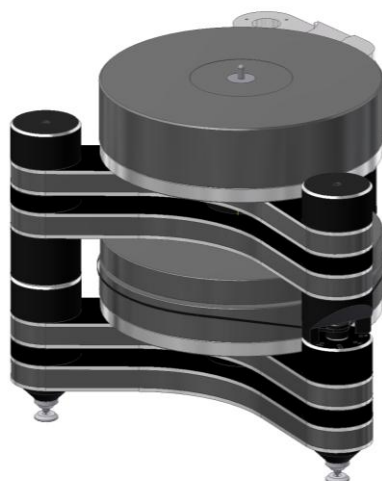

Pic. 15: Finished set - up

You will find suitable adjustment equipment under www.clearaudio.de or www.analogshop.de

12.)

To install the tonearm, please follow the user manual of the respective manufacturer.

If you purchased your **clearaudio Innovation** turntable as a package with tonearm and cartridge, you will find a Smart Level Gauge in your accessory, which will help you to adjust the Tracking Force of the cartridge:

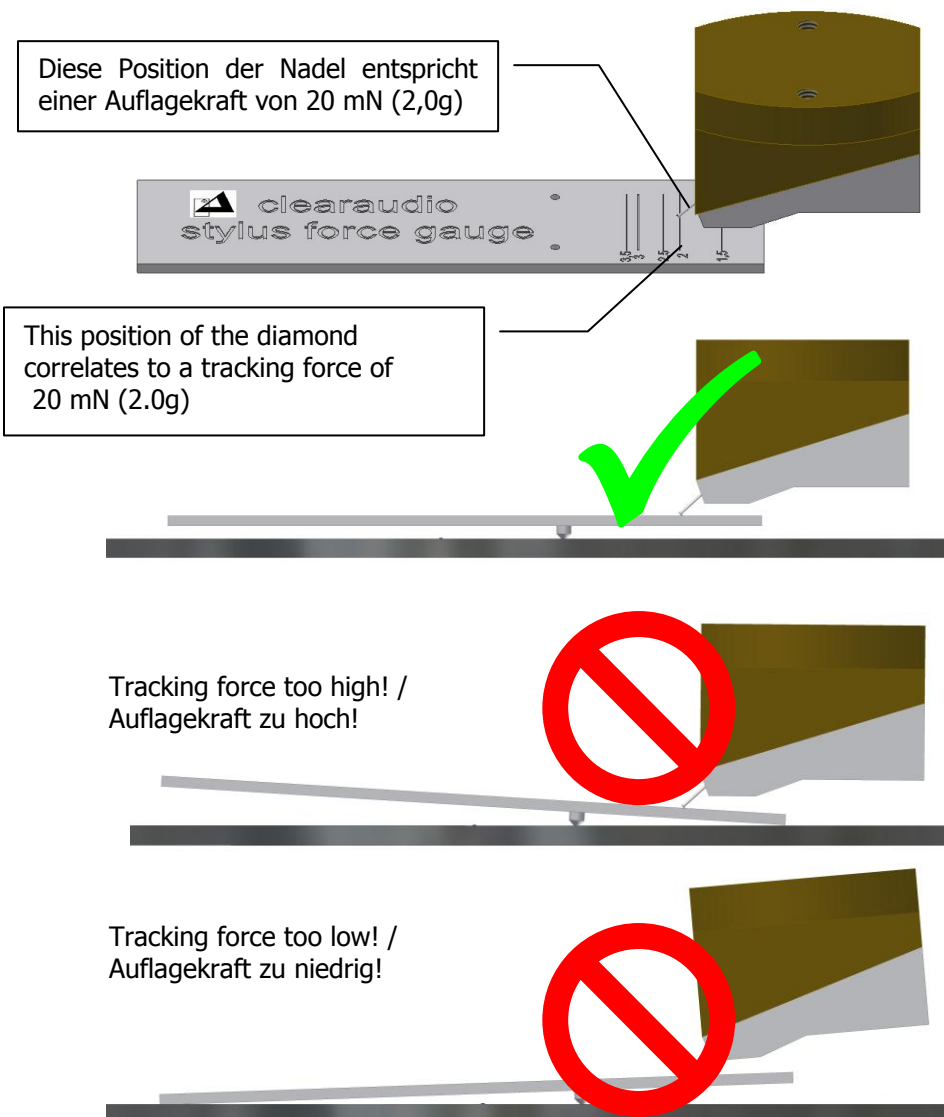

Pic. 16: Use of Smart Stylus Gauge

13.)

To mount and adjust a cartridge, please follow the user manual of the respective manufacturer.

14.)

The following final adjustment is very important:

Please ensure that your turntable rack is in a levelled position.

Please check with the bubble level gauge, if your *Master Innovation* turntable is in a levelled position.

You can adjust each of the turntable's feet to get the turntable levelled.

Only if the turntable is in a levelled position you will get the best results with your *Master Innovation* turntable.



Pic 17a: Alignment of the turntable

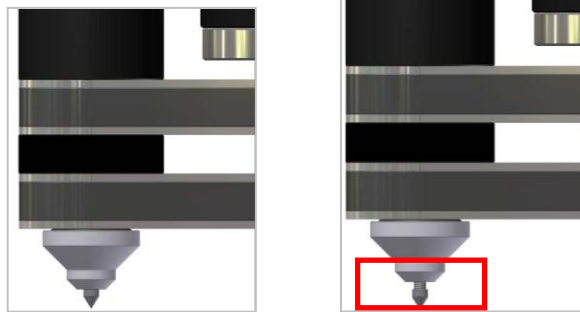

Pic. 17b: Adjustment of the height

15.)

Please connect the mains plug to your power supply.

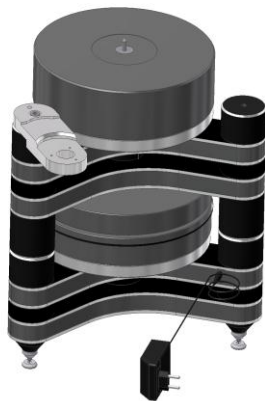

Pic. 18: Connection power supply and motor

16.)

By pushing the sensor-switch, marked with "33 1/3" on the motor, the turntable starts to spin until 33 1/3 rpm is reached. After the initial set-up we recommend to let the turntable spin for at least 15 to 30 minutes.

This ensures a smoother break in.

4. Fine adjustment of the *Master Innovation* motor

1.)

The Master Innovation is ready to play after ending the modification. But through the rebuilding speed differences could occur, because a complete new turntable is formed. In this case you have to correct the speed. Please proceed as described below.

For the correct adjustment of the speed please put the recommended **clearaudio** Stroboscope Testrecord on the platter (See accessory pack Innovation turntable). Follow hereby the instruction of the Stroboscope Testrecord user manual. To check the speed with highest accuracy please use the **clearaudio** Speed Light (AC039) (www.analogshop.de).

On the front side of your turntable there are three setting trimmers (see pic. 15).

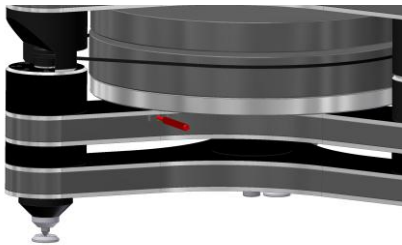

- left trimmer = setting 33 1/3 rpm (near turntable motor)
- middle trimmer = setting 45 rpm
- right trimmer = setting 78 rpm (near turntable bearing)

Pic. 18: Fine adjustment of the motor

If you like to adjust the speed 33 1/3 rpm , take the aluminium screw driver (see accessories) and turn the left trimmer until you have reached the right speed according to the Stroboscope Testrecord (see user manual "Stroboscope Testrecord").

- Turning the trimmer counter clockwise = reduces the turntable speed
- Turning the trimmer clockwise = raises the turntable speed

Please proceed with the speed adjustment for 45 rpm and 78 rpm in the same way!

Please note:

If the turntable does not reach the correct speed, the sensor or the scale ring could be dirty or dusty.

To clean the sensor, please take off the two platters very carefully !

Clean the sensor and the scale ring with a little isopropyl alcohol and a cotton bud.

Be careful and avoid any scratches on the sensor or the scale ring!

If the motor has further more speed variations please contact your nearest authorized **clearaudio** dealer or directly the **clearaudio** factory.

Now you are finally ready to play your vinyl records.

We wish you a lot of pleasure with your new *Master Innovation*-turntable.



Upgrade Innovation to Master Innovation

User manual

5. Service and special instruction

In case of any necessary, service for all **clearaudio** products should be done by authorized personal only.

In case of any repair, the clearaudio *Innovation*-turntable needs to be send to your nearest authorized **clearaudio** distributor, dealer or directly to the **clearaudio** factory.

clearaudio electronic GmbH
Spardorfer Str. 150
91054 Erlangen
Germany
Tel/Phone: +49-(0)9131/40 300 100
www.clearaudio.de
www.analogshop.de
info@clearaudio.de

Send / ship the *Master Innovation* -turntable always and only in the original packing !!!

Only in the original packing **clearaudio** can provide the warranty.

If you repackage the turntable, please make all steps inverted like at installation and set - up (chapter 3).

5.1 Special instruction

To achieve the full **clearaudio** warranty (for the *Master Innovation* turntable 5 years), it is necessary that you fill out and send the **corresponding part of the warranty registration card back to clearaudio**, within two weeks after purchase.

Only if the product is returned in it's original packing **clearaudio** can provide the warranty.

Transportation advice:

If any transportation of the *Master Innovation*-turntable should be necessary, please always remove the turntable platter and the shaft holder. Otherwise serious damage can occur! To avoid any dust coming into the bearing, the bearing hole needs to be covered as well.

If the *Master Innovation* -turntable is a longer time not in use, please disconnect the motor from the main supply.

Every two years you can lubricate the bearing of the turntable platter with the delivered oil. In this case it is enough to put 1 or 2 drops of the oil into bearing.

Please take special caution to any damages of the power cord. Any damages should be repaired only by authorized personal.

A damaged power cord must be exchanged immediately!

Caution !

Please use only non-alcoholic fluids and only fluids specially used for acrylic, to clean the *Master Innovation* -turntable.

Otherwise damage on the material or the surface can occur!

Don't use dry cloths for cleaning because of the electrostatic charging.

Suitable cleaning fluids will be available at clearaudio (www.analogshop.de) or yourhifi dealer.

6. Technical data

Construction principle:	Resonance optimised chassis's shape, belt driven with optical, full automatic speed control
Speed possibilities:	33 1/3 rpm / 45 rpm / 78 rpm
Drive unit:	Decoupled DC motor in a massive metal-housing. Motor can be used with 100 V (50 Hz) and with 240 V (60 Hz)
Bearing	Drive bearing: Inverted and polished ceramic bearing shaft, polished sinter bronze insert, including patented CMB bearing technology Platter bearing: Inverted and polished bearing shaft, including patented CMB bearing technology
Platter:	VA stainless steel sub-platter, Delrin or acrylic GS-PMMA platter, precision CNC machined surface
Speed variation less than:	±0.05 %
Deviance of the set value:	±0.01 %
Weight:	approx. 60 kg (without power supply unit)
Dimensions (in inches):	approx. 18.9 x 19.1 x 16.7
Warranty:	5 years* (see page 17)

* Only if the warranty card is filled out correctly and sent back to **clearaudio** within 14 days.

clearaudio electronic is not responsible for typographical errors in descriptions. Technical specifications subject to change or improvement without prior notice. Availability as long as stock lasts. Copies and imprints- also only in extracts – require written conformation through **clearaudio** electronic GmbH; Germany
© clearaudio electronic GmbH 2014

Stand: April 2014

To achieve the full **clearaudio** warranty (*Master Innovation* turntable 5 years), it is necessary that you fill out and send the corresponding part of the warranty registration certificate /card back to **clearaudio**, within two weeks after purchase. Only if the product is returned in it's original packing **clearaudio** can provide the warranty of 5 years.

ENGLISH **WARRANTY**

For warranty information, contact your local clearaudio distributor.

RETAIN YOUR PURCHASE RECEIPT

Your purchase receipt is your permanent record of a valuable purchase.

It should be kept in a safe place to be referred to as necessary for insurance purposes or when corresponding with clearaudio.

IMPORTANT

When seeking warranty service, it is the responsibility of the consumer to establish proof and date of purchase. Your purchase receipt or invoice is adequate for such proof.

FOR U.K. ONLY

This undertaking is in addition to a consumer's statutory rights and does not affect those rights in any way.

FRANÇAIS **GARANTIE**

Pour des informations sur la garantie, contacter le distributeur local clearaudio.

CONSERVER L'ATTESTATION D'ACHAT

L'attestation d'achat est la preuve permanente d'un achat de valeur. La conserver en lieu sûr pour s'y reporter aux fins d'obtention d'une couverture d'assurance ou dans le cadre de correspondances avec clearaudio.

IMPORTANT

Pour l'obtention d'un service couvert par la garantie, il incombe au client d'établir la preuve de l'achat et d'en corroborer la date. Le reçu ou la facture constituent des preuves suffisantes.

DEUTSCH **GARANTIE**

Bei Garantiefragen wenden Sie sich bitte zunächst an Ihren clearaudio-Händler.

Heben Sie Ihren Kaufbeleg gut auf.

WICHTIG!

Die Angaben auf Ihrer Quittung erlauben uns die Identifizierung Ihres Gerätes und belegen mit dem Kaufdatum die Dauer Ihrer Garantie-Ansprüche.

Für Serviceleistungen benötigen wir stets die Gerätenummer.

Diese finden Sie auf dem Typenschild auf der Rückseite des Gerätes oder auch in der beigelegten Garantie-Registrierkarte.

NEDERLANDS **GARANTIE**

Voor inlichtingen omtrent garantie dient u zich tot uw plaatselijke clearaudio.

UW KWITANTIE, KASSABON E.D. BEWAREN

Uw kwitantie, kassabon e.d. vormen uw bewijs van aankoop van een waardevol artikel en dienen op een veilige plaats bewaard te worden voor evt, verwijzing bijv, in verband met verzekering of bij correspondentie met clearaudio.

BELANGRIJK

Bij een evt, beroep op de garantie is het de verantwoordelijkheid van de consument een gedateerd bewijs van aankoop te tonen. Uw kassabon of factuur zijn voldoende bewijs.

ITALIANO **GARANZIA**

L'apparecchio è coperto da una garanzia di buon funzionamento della durata di un anno, o del periodo previsto dalla legge, a partire dalla data di acquisto comprovata da un documento attestante il nominativo del Rivenditore e la data di vendita. La garanzia sarà prestata con la sostituzione o la riparazione gratuita delle parti difettose.

Non sono coperti da garanzia difetti derivanti da uso improprio, errata installazione, manutenzione effettuata da personale non autorizzato o, comunque, da circostanze che non possano riferirsi a difetti di funzionamento dell'apparecchio. Sono inoltre esclusi dalla garanzia gli interventi inerenti l'installazione e l'allacciamento agli impianti di alimentazione.

Gli apparecchi verranno riparati presso i nostri Centri di Assistenza Autorizzati. Le spese ed i rischi di trasporto sono a carico del cliente. La casa costruttrice declina ogni responsabilità per danni diretti o indiretti provocati dalla inosservanza delle prescrizioni di installazione, uso e manutenzione dettagliate nel presente manuale o per guasti dovuti ad uso continuato a fini professionali.

ESPAÑOL **GARANTIA**

Para obtener información acerca de la garantía póngase en contacto con su distribuidor clearaudio.

GUARDE SU RECIBO DE COMPRA

Su recibo de compra es su prueba permanente de haber adquirido un aparato de valor, Este recibo deberá guardarlo en un lugar seguro y utilizarlo como referencia cuando tenga que hacer uso del seguro o se ponga en contacto con clearaudio.

IMPORTANTE

Cuando solicite el servicio otorgado por la garantía el usuario tiene la responsabilidad de demostrar cuándo efectuó la compra. En este caso, su recibo de compra será la prueba apropiada.