

PROPANE CONSTRUCTION HEATERS

OWNER'S MANUAL

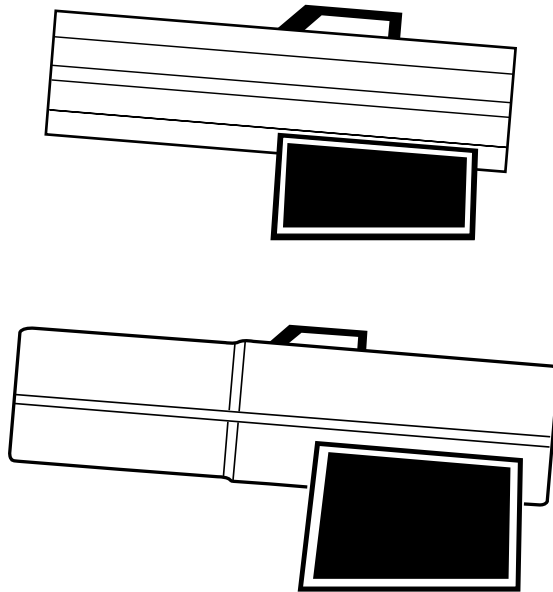

Heater Sizes: 80,000 150,000 BTU/Hr

IMPORTANT

Read and understand this manual before assembling, starting, or servicing heater. Improper use of heater can cause serious injury. Keep this manual for future reference.

GENERAL HAZARD WARNING:

FAILURE TO COMPLY WITH THE PRECAUTIONS AND INSTRUCTIONS PROVIDED WITH THIS HEATER, CAN RESULT IN DEATH, SERIOUS BODILY INJURY AND PROPERTY LOSS OR DAMAGE FROM HAZARDS OF FIRE, EXPLOSION, BURN, ASPHYXIATION, CARBON MONOXIDE POISONING, AND/OR ELECTRICAL SHOCK.

ONLY PERSONS WHO CAN UNDERSTAND AND FOLLOW THE INSTRUCTIONS SHOULD USE OR SERVICE THIS HEATER.

IF YOU NEED ASSISTANCE OR HEATER INFORMATION SUCH AS AN INSTRUCTIONS MANUAL, LABELS, ETC. CONTACT THE MANUFACTURER.



CONTENTS

SECTION	PAGE
Safety Information	2
Product Identification	4
Unpacking	5
Theory of Operation	5
Propane Supply	6
Installation	6
Ventilation	7
Operation	8
Storage	8
Maintenance	9
Preventative Maintenance Schedule	9
Service Procedures	10
Specifications	12
Wiring Diagrams	13
Accessories	15
Technical Service	15
Service Publications	15
Replacement Parts	15
Warranty and Repair Service	Back Cover

SAFETY INFORMATION

WARNINGS

 WARNING: FIRE, BURN, INHALATION, AND EXPLOSION HAZARD. KEEP SOLID COMBUSTIBLES, SUCH AS BUILDING MATERIALS, PAPER OR CARDBOARD, A SAFE DISTANCE AWAY FROM THE HEATER AS RECOMMENDED BY THE INSTRUCTIONS. NEVER USE THE HEATER IN SPACES WHICH DO OR MAY CONTAIN VOLATILE OR AIRBORNE COMBUSTIBLES, OR PRODUCTS SUCH AS GASOLINE, SOLVENTS, PAINT THINNER, DUST PARTICLES OR UNKNOWN CHEMICALS.

WARNING

NOT FOR HOME OR RECREATIONAL VEHICLE USE.

The heater is designed and approved for use as a construction heater under ANSI Z83.7. The primary purpose of construction heaters is to provide temporary heating of buildings under construction, alteration or repair, and to provide temporary emergency heat. Properly used, the heater provides safe economical heating. Products of combustion are vented into the area being heated.

We cannot foresee every use which may be made of our heaters. **Check with your local fire safety authority if you have questions about heater use.**

Other standards govern the use of fuel gases and heat producing products for specific uses. Your local authorities can advise you about these.

Carbon Monoxide Poisoning: Some people are more affected by carbon monoxide than others. Early signs of carbon monoxide poisoning resemble the flu, with headaches, dizziness, and/or nausea. If you have these signs, the heater may not be working properly. **Get fresh air at once!** Have heater serviced.

Safety Information continues on next page

SAFETY INFORMATION

Continued

WARNINGS

Propane Gas: Propane gas is odorless. An odor-making agent is added to propane gas. The odor helps you detect a propane gas leak. However, the odor added to propane gas can fade. Propane gas may be present even though no odor exists. Make certain you read and understand all Warnings. Keep this manual for reference. It is your guide to safe and proper operation of this heater.

- For indoor use only. Provide adequate ventilation.
- Use only in well vented areas. Before using heater, provide at least a three-square-foot opening of fresh, outside air for each 100,000 BTU/Hr of rating. This heater produces carbon monoxide, which is listed by the State of California as a reproductive toxin under Proposition 65.
- Do not use heater outdoors or in occupied dwellings.
- Do not use heater in living or sleeping quarters.
- Keep appliance area clear and free from combustible materials, gasoline, paint thinner, and other flammable vapors and liquids. Do not use heater in areas with high dust content.
- Keep heater away from strong drafts, water spray, rain, or dripping water.
- Install and use heater with care. Follow all local ordinances and codes. In the absence of local ordinances and codes, refer to ANSI/NFPA 58. This instructs on the safe storage and handling of propane gases.
- Check heater for damage before each use. Do not use a damaged heater.
- Use only propane gas set up for vapor withdrawal.
- Keep propane tank(s) below 100° F.
- Do not use heater below ground level. Propane gas is heavier than air. If a leak occurs, propane gas will sink to the lowest possible level.
- Use only the electrical voltage and frequency specified on model plate.
- The electrical connections and grounding of the heater shall follow the National Electric Code, ANSI/NFPA 70.
- Electrical grounding instructions — This appliance is equipped with a three-prong (grounding) plug for your protection against shock hazard and should be plugged directly into a properly grounded three-prong receptacle.
- Use only a three-prong, grounded extension cord.
- Use only the hose and factory preset regulator provided with the heater.
- Inspect hose before each use of heater. If highly worn or cut, replace before using heater. Use the replacement hose assembly specified in this manual.
- Keep heater at least six feet from propane tank(s). Do not point heater at propane tank(s) within 20 feet.
- Minimum heater clearances from combustibles:
Outlet: 8 Ft. Sides: 2 Ft. Top: 6 Ft. Rear: 2 Ft.
- Locate heater on stable and level surface if heater is hot or running.
- Keep children and animals away from heater.
- Turn off propane supply and unplug heater when not in use.
- When used with thermostat, heater may start anytime.
- Never block air inlet (rear) or air outlet (front) of heater.
- Never move, handle, or service a hot, operating, or plugged-in heater.
- Do not alter heater. Keep heater in its original state.
- Do not use heater if altered.
- Never attach duct work to front or rear of heater.
- Use only original replacement parts. This heater must use design-specific parts. Do not substitute or use generic parts. Improper replacement parts could cause serious or fatal injuries.

PRODUCT IDENTIFICATION

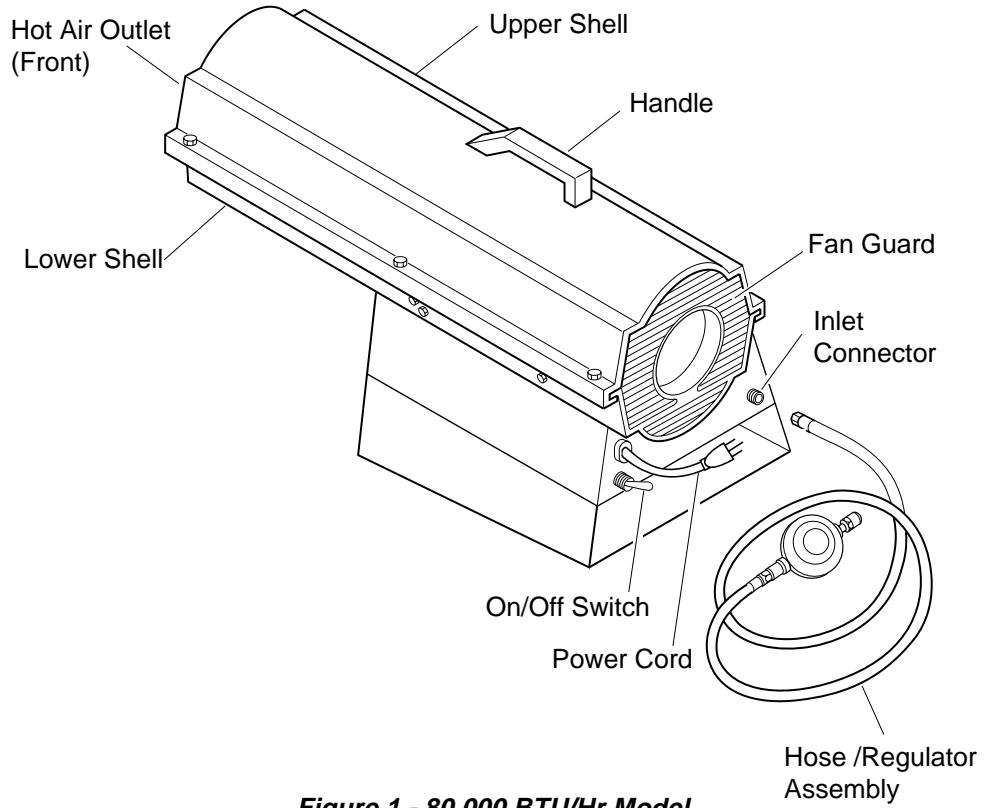

Figure 1 - 80,000 BTU/Hr Model

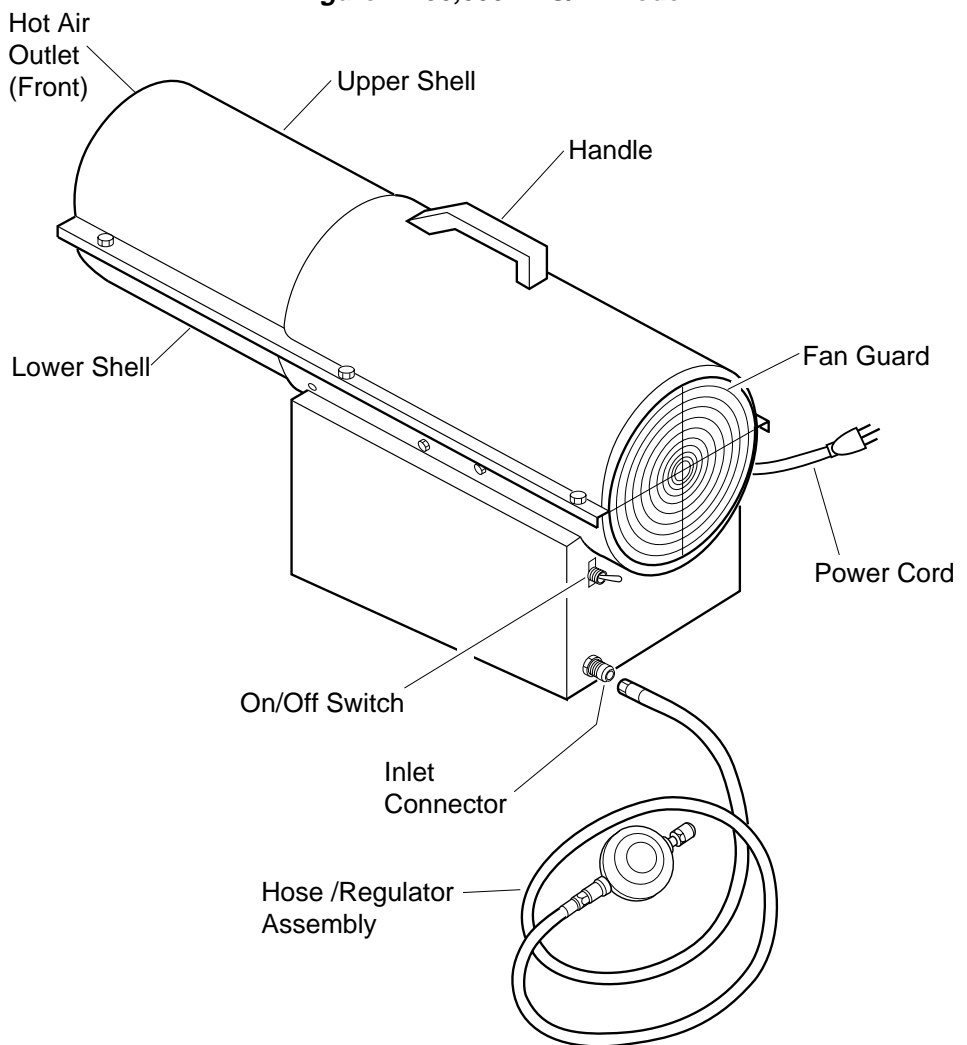

Figure 2 - 150,000 BTU/Hr Model

UNPACKING

1. Remove all packing items applied to heater for shipment. Keep plastic cover caps (attached to inlet connector and hose/regulator assembly) for storage.
2. Remove all items from carton.
3. Check all items for shipping damage. If heater is damaged, promptly inform dealer where you bought heater.

THEORY OF OPERATION

The Fuel System: The hose/regulator assembly attaches to the propane gas supply. The propane gas moves through the solenoid valve and out the nozzle.

The Air System: The motor turns the fan. The fan pushes air into and around the combustion chamber. This air is heated and provides a stream of clean, hot air.

The Ignition System: The direct spark ignitor (DSI) sends voltage to the spark plug/ignitor. The spark plug/ignitor ignites the fuel and air mixture.

The Safety Control System: This system causes the heater to shut down if the flame goes out.

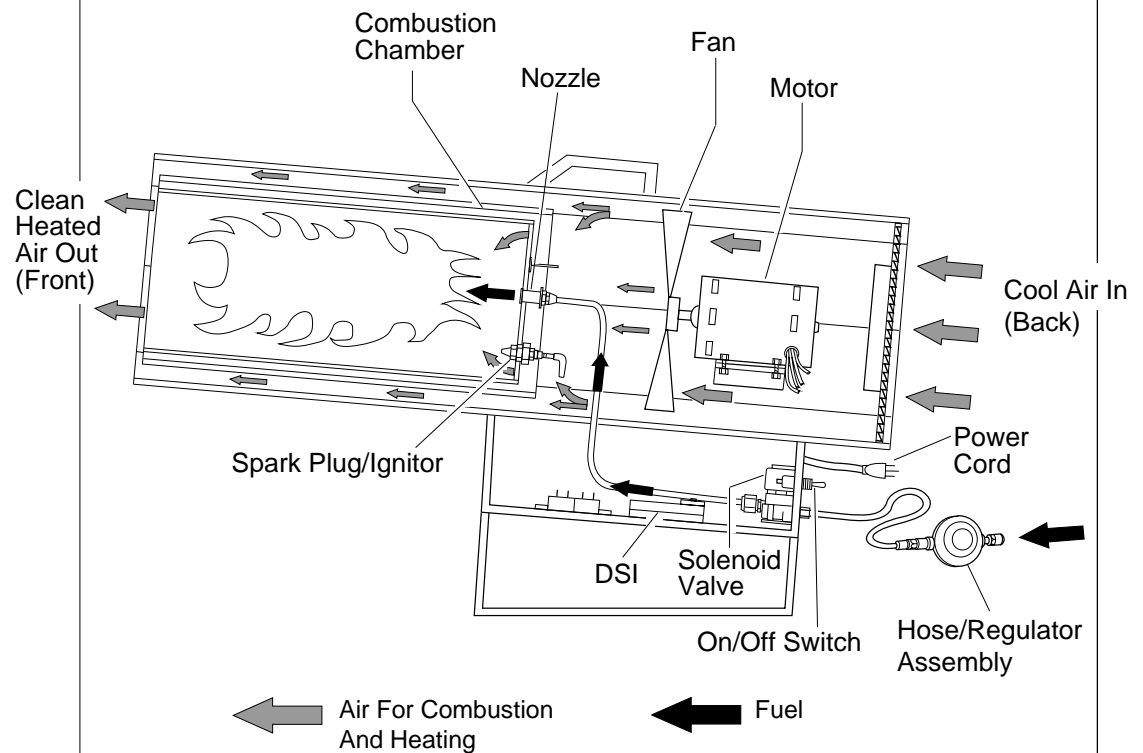

Figure 3 - Cross Section Operational View (80,000 BTU/Hr Model Shown)

Note: Some parts are located differently on some models.

PROPANE SUPPLY

Propane gas and propane tank(s) are to be furnished by the user.

Use this heater only with a propane vapor withdrawal supply system. See Chapter 5 of the *Standard for Storage and Handling of Liquefied Petroleum Gas, ANSI/NFPA 58*. Your local library or fire department will have this booklet.

The amount of propane gas ready for use from propane tanks varies. Two factors decide this amount:

1. The amount of propane gas in tank(s)
2. The temperature of tank(s)

The chart below shows the number of 100 pound tanks needed to run this heater. Do not operate this product with any tank smaller than 100 pounds.

	Temperature (°F) At Tank					
	32°	20°	10°	0°	-10°	-20°
Number of tanks, 80,000 BTU/Hr	1	1	2	2	3	3
Number of tanks, 150,000 BTU/Hr	2	2	3	3	(Use larger tank)	

Less gas is vaporized at lower temperatures. You may need two or more 100 pound tanks or one larger tank in colder weather. Your local propane gas dealer will help you select the proper supply system. The minimum surrounding air temperature rating for each heater is -20°F (-29°C).

INSTALLATION

⚠ WARNING

Review and understand the warnings in the Safety Information Section, pages 2 and 3. They are needed to safely operate this heater. Follow all local codes when using this heater.

⚠ WARNING

Test all gas piping and connections for leaks after installing or servicing. Never use an open flame to check for a leak. Apply a mixture of liquid soap and water to all joints. Bubbles forming show a leak. Correct all leaks at once.

1. Provide propane supply system (see Propane Supply above).
2. Connect POL fitting on hose/regulator assembly to propane tank(s). Turn POL fitting counterclockwise into threads on tank. Tighten firmly using 7/8" wrench. **IMPORTANT:** Tighten regulator with vent pointing down. Pointing vent down protects regulator from weather damage.

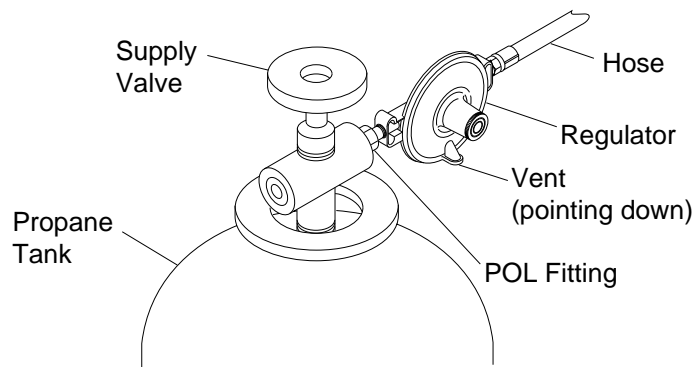

Figure 4 - Regulator With Vent Pointing Down

Continued

3. Connect hose to inlet connector. Tighten firmly using a wrench.
IMPORTANT: Extra hose or piping may be used if needed. Install extra hose or piping between hose/regulator assembly and propane tank. You must use the regulator supplied with heater.

80,000 BTU/Hr
Model Shown

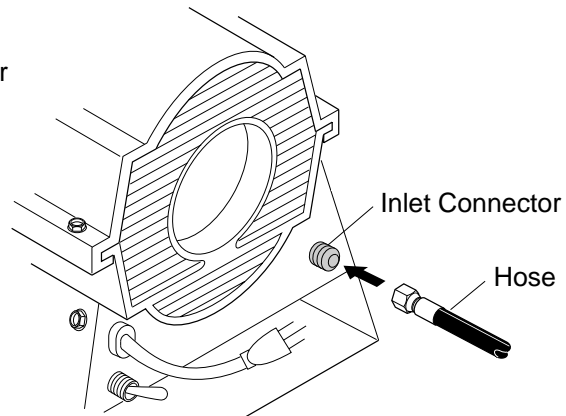

Figure 5 - Hose and Inlet Connector

4. Open propane supply valve on propane tank(s) slowly. *Note:* If not opened slowly, excess-flow check valve on propane tank will stop gas flow. If this happens, close propane supply valve and open again slowly.
5. Check all connections for leaks.

⚠ WARNING

Never use an open flame to check for a leak. Apply a mixture of liquid soap and water to all joints. Bubbles forming show a leak. Correct all leaks at once.

6. Close propane supply valve.

⚠ WARNING

Follow the minimum fresh, outside air ventilation requirements. If proper fresh, outside air ventilation is not provided, carbon monoxide poisoning can occur. Provide proper fresh, outside air ventilation before running heater.

Provide a fresh air opening of at least three square feet for each 100,000 BTU/Hr rating. Provide extra fresh air if more heaters are being used.

Example: A 150,000 BTU/Hr heater requires one of the following:

- a two-car garage door raised six inches
- a single-car garage door raised nine inches
- two thirty-inch windows raised twelve inches

VENTILATION

OPERATION

WARNING

Review and understand the warnings in the Safety Information Section, pages 2 and 3. They are needed to safely operate this heater. Follow all local codes when using this heater.

To Start Heater

1. Follow all installation, ventilation and safety information.
2. Locate heater on stable and level surface. Make sure strong drafts do not blow into front or rear of heater.
3. Plug power cord of heater into a three-prong, grounded extension cord. Extension cord must be at least six feet long. Extension cord must be UL listed.

Extension Cord Size Requirement

Up to 50 feet long, use 18 AWG rated cord.

51 to 100 feet long, use 16 AWG rated cord.

101 to 200 feet long, use 14 AWG rated cord.

4. Plug extension cord into a 120 volt/60 hertz, three-hole, grounded outlet.
5. Open propane supply valve on propane tank(s) slowly. *Note:* If not opened slowly, excess-flow check valve on propane tank will stop gas flow. If this happens, close propane supply valve and open again slowly.
6. Turn on/off switch to the ON position. Heater will start within twenty seconds. *Note:* If heater does not start, turn on/off switch to the OFF position. Wait ten seconds for safety control to reset, then try again.

To Stop Heater

1. Tightly close propane supply valve on propane tank(s).
2. Wait a few seconds. Heater will burn gas left in supply hoses.
3. Turn on/off switch to the OFF position.
4. Unplug heater.

STORAGE

CAUTION

Disconnect heater from propane supply tank(s).

1. Store propane tank(s) in safe manner. See Chapter 5 of *Standard for Storage and Handling of Liquefied Petroleum Gases, ANSI/NFPA 58*. Follow all local codes.
2. Place plastic cover caps over brass fittings on inlet connector and hose/regulator assembly.
3. Store in dry, clean, and safe place. Do not store hose/regulator assembly inside heater combustion chamber.
4. When taking heater out of storage, always check inside of heater. Insects and small animals may place foreign objects in heater. Keep inside of heater free from combustible and foreign objects.

MAINTENANCE

WARNING

Never service heater while it is plugged in, connected to propane supply, operating, or hot. Severe burns and electrical shock can occur.

1. Keep heater clean. Clean heater annually or as needed to remove dust and debris. If heater is dirty or dusty, clean heater with a damp cloth.
2. Inspect heater before each use. Check connections for leaks. Apply mixture of liquid soap and water to connections. Bubbles forming show a leak. Correct all leaks at once.
3. Inspect hose/regulator assembly before each use. If hose is highly worn or cut, replace.
4. Have heater inspected yearly by a qualified service agency.
5. Keep inside of heater free from combustible and foreign objects.

PREVENTATIVE MAINTENANCE SCHEDULE

WARNING

Never service heater while it is plugged in, connected to propane supply, operating, or hot. Severe burns and electrical shock can occur.

<u>Item</u>	<u>How Often</u>	<u>How To</u>
Fan	Clean every 500 hours of operation or as needed.	See Fan, page 10.
Air Sensing Switch (80,000 BTU/Hr Model Only)	Clean every 500 hours of operation or as needed.	See Air Sensing Switch, page 11.
Spark Plug (80,000 BTU/Hr Model Only)	Clean and regap every 500 hours of operation or replace as needed.	See Spark Plug, page 11.

SERVICE PROCEDURES

Upper Shell Removal

1. Remove screws along each side of heater using 5/16" nut-driver. These screws attach upper and lower shells together.
2. Lift or slide upper shell off.
3. Remove fan guard.

Fan

IMPORTANT: Remove fan from motor shaft before removing motor from heater. The weight of the motor resting on the fan could damage the fan pitch.

1. Remove upper shell (see above).
2. Use 1/8" hex wrench to loosen setscrew which holds fan to motor shaft.
3. Slip fan off motor shaft. Be careful not to strike air sensing switch paddle or paddle arm (80,000 BTU/Hr model only).
4. Clean fan using soft cloth moistened with kerosene or solvent.
5. Dry fan thoroughly.
6. Replace fan on motor shaft. Make sure setscrew is touching back of flat surface on motor shaft (see Figure 10).
7. Place setscrew on flat of shaft. Tighten setscrew firmly (40-50 inch-pounds).
8. Replace fan guard and upper shell.

⚠ WARNING

Never service heater while it is plugged in, connected to propane supply, operating, or hot. Severe burns and electrical shock can occur.

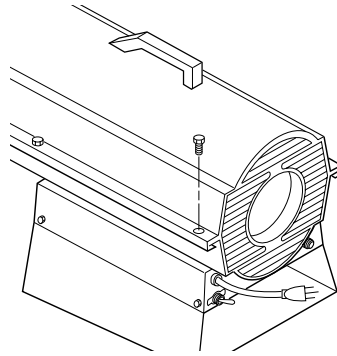

Figure 6 - Upper Shell Removal, 80,000 BTU/Hr Model

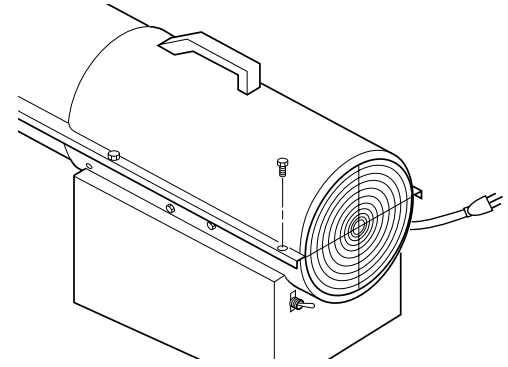

Figure 7 - Upper Shell Removal, 150,000 BTU/Hr Model

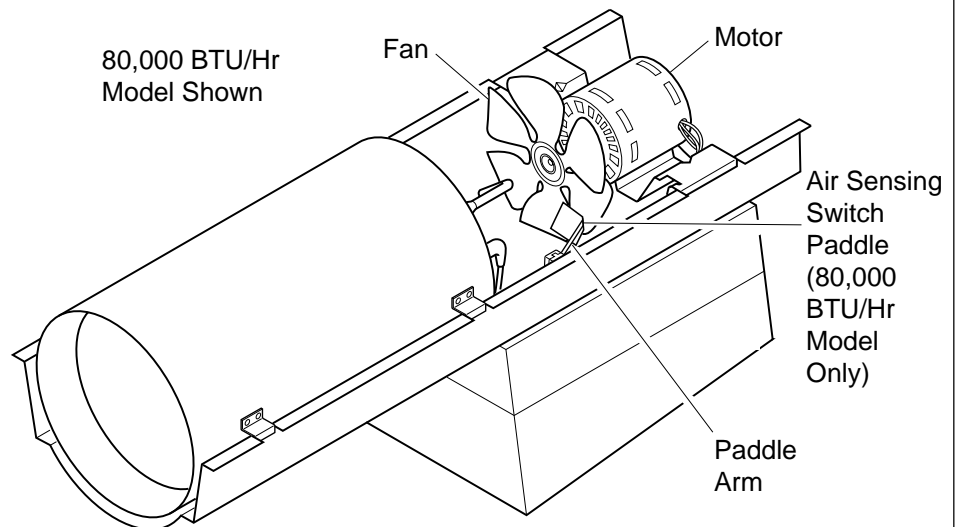

Figure 8 - Fan Removal and Air Sensing Switch Location

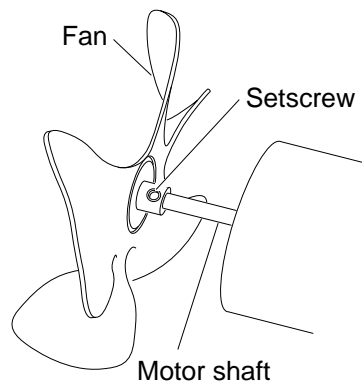

Figure 9 - Fan, Motor Shaft, and Setscrew Location

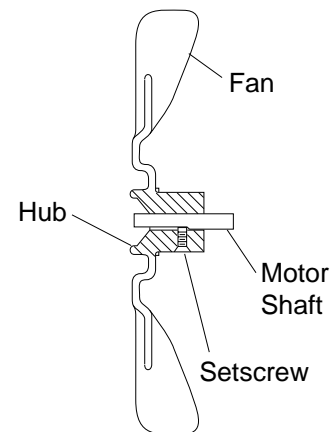

Figure 10 - Fan Cross Section

Air Sensing Switch (80,000 BTU/Hr Model)

1. Remove upper shell (see page 10).
2. Clean air sensing switch paddle. Use soft cloth moistened with kerosene or solvent. **IMPORTANT:** Do not scrub. Use gentle cleaning action. Do not bend paddle or paddle arm.
3. Blot paddle dry with a soft cloth.
4. Replace fan guard and upper shell.

Ignitor

(150,000 BTU/Hr Model)

1. Make sure gap between ignitor electrode and burner nozzle is .13/.15". Access ignitor electrode from inside combustion chamber. No other maintenance is needed for ignitor.

Spark Plug

(80,000 BTU/Hr Model)

1. Remove upper shell (see page 10).
2. Remove fan (see page 10).
3. Remove spark plug cable from spark plug.
4. Place 11/16" socket onto spark plug mounting nut. Spark plug mounting nut is located on spark plug threads inside combustion chamber (see Figures 12 and 14).
5. Loosen and remove spark plug with 13/16" spark plug socket. Be careful not to strike air sensing switch paddle.
6. Clean and regap spark plug electrodes. Regap electrodes to .06/.08 inch.

Continued

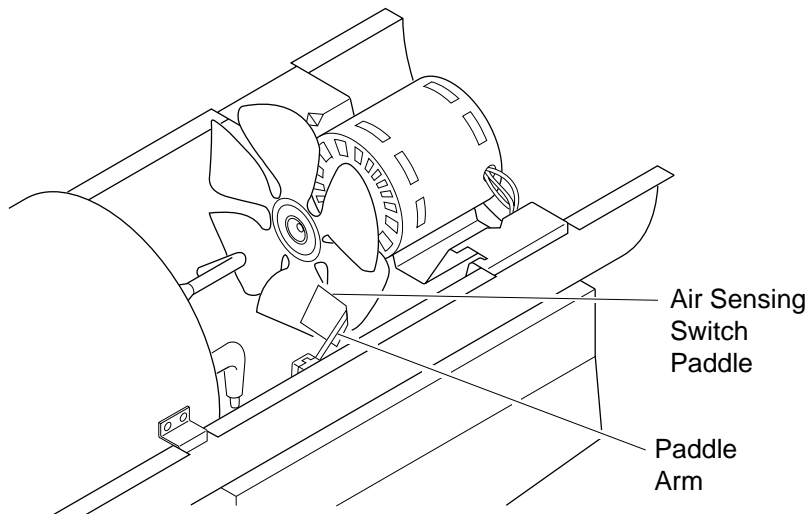

Figure 11 - Air Sensing Switch Location, 80,000 BTU/Hr Model Only

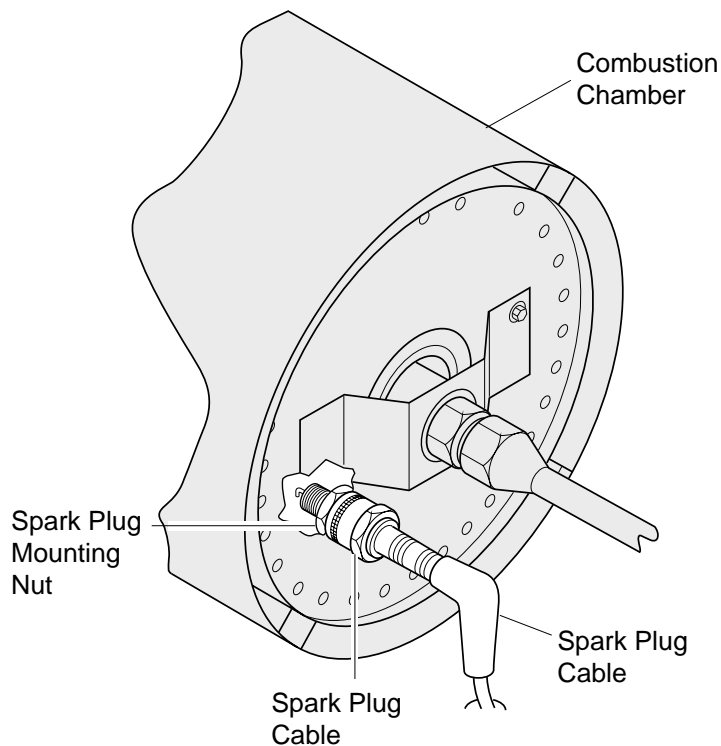

Figure 12 - Spark Plug and Spark Plug Mounting Nut Location on Combustion Chamber

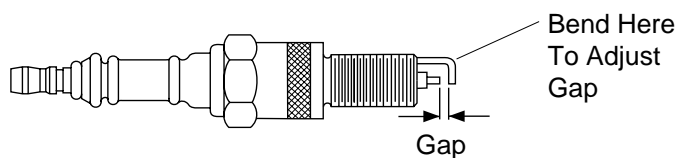

Figure 13 - Spark Plug Gap

7. Replace spark plug into combustion chamber. Tighten spark plug mounting nut finger tight onto spark plug threads. Use 11/16" socket to hold spark plug mounting nut. Tighten spark plug to spark plug mounting nut using 13/16" spark plug socket.
8. Attach spark plug cable to spark plug.
9. Replace fan (see page 10).
10. Replace fan guard and upper shell.

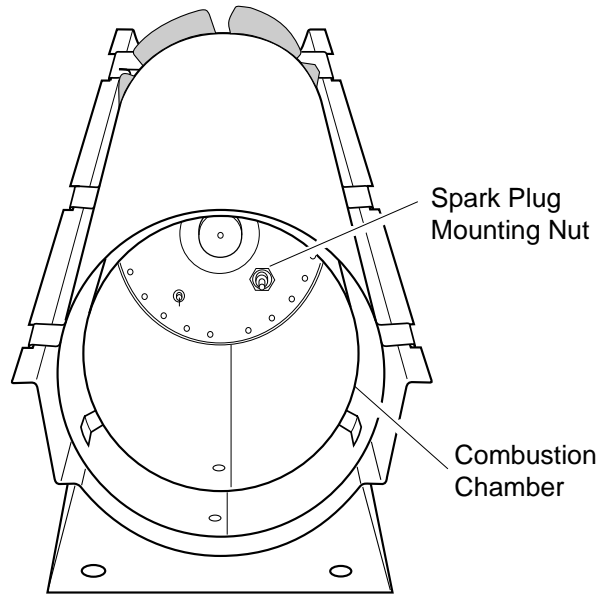

Figure 14 - Spark Plug Mounting Nut Location

SPECIFICATIONS

Output Rating (BTU/Hr)	80,000	150,000
Fuel	Propane Vapor Only For All Models	
Fuel Consumption		
Gallons/Hour	0.9	1.6
Pounds/Hour	3.7	7.0
Supply Pressure To Regulator		
Minimum (for purposes of input adjustment)	10 psi	10 psi
Maximum	Tank Pressure For All Models	
Regulator Outlet Pressure (Factory Preset)	11" WC	12.5" WC
Manifold Pressure	9" WC	9.8" WC
Hot Air Output (CFM Approx)	350	550
Motor	3,400 RPM, 1/10 HP	3,430 RPM, 1/8 HP
Electric Input	120 V/60 Hz	120 V/60 Hz
Amperage	3	2.2
Ignition	Direct Spark, Interrupted Type For All Models	
Spark Plug Gap (Inches)	.06/.08	N/A
Ignitor Gap (Inches)	N/A	.13/.15
Weight (Pounds)		
Heater	26	24
Shipping	30	35
Size - L x W x H (Inches)	29 ¹ / ₂ x 12 x 18 ¹ / ₂	36 ¹ / ₄ x 14 ¹ / ₂ x 20

WIRING DIAGRAMS

80,000 BTU/Hr Model

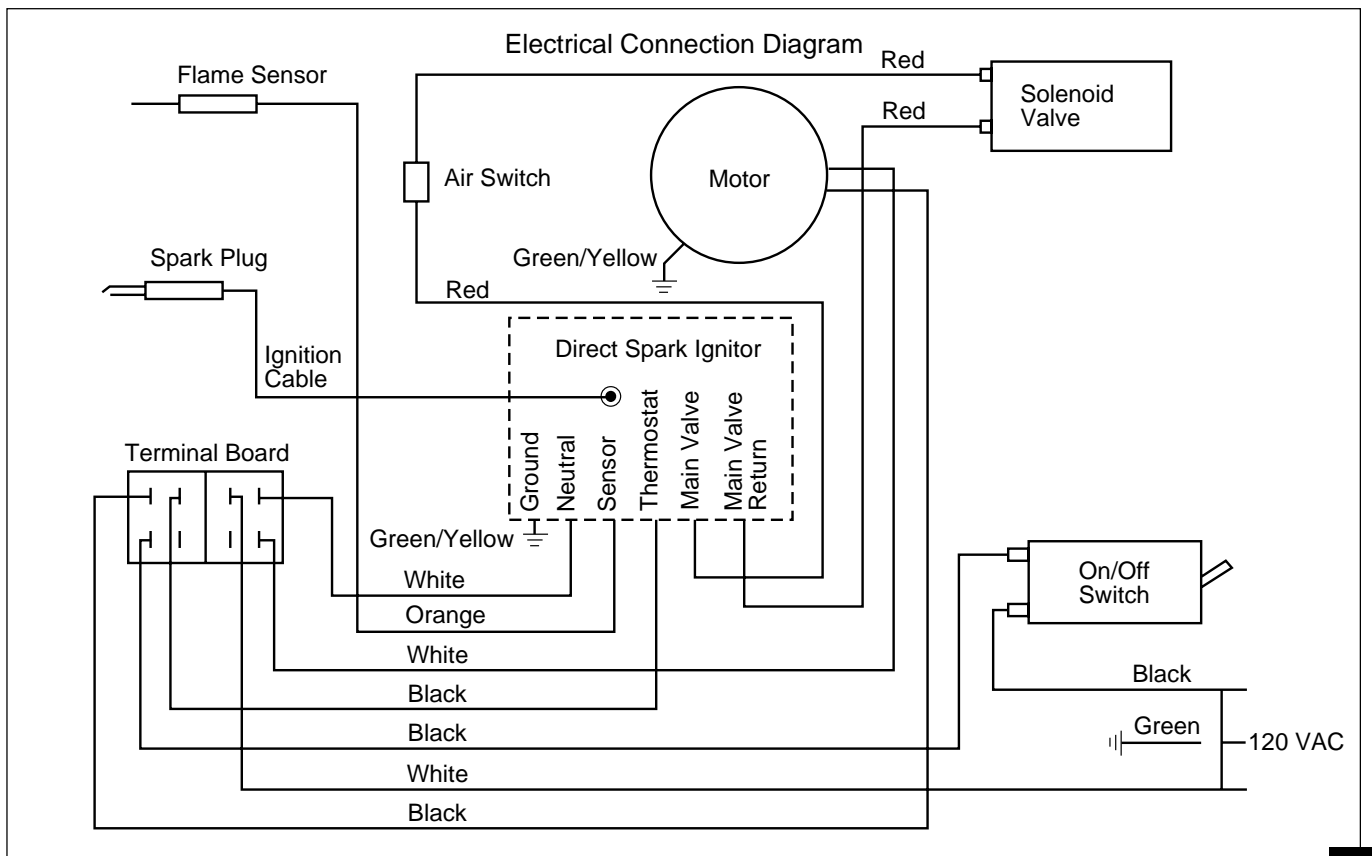
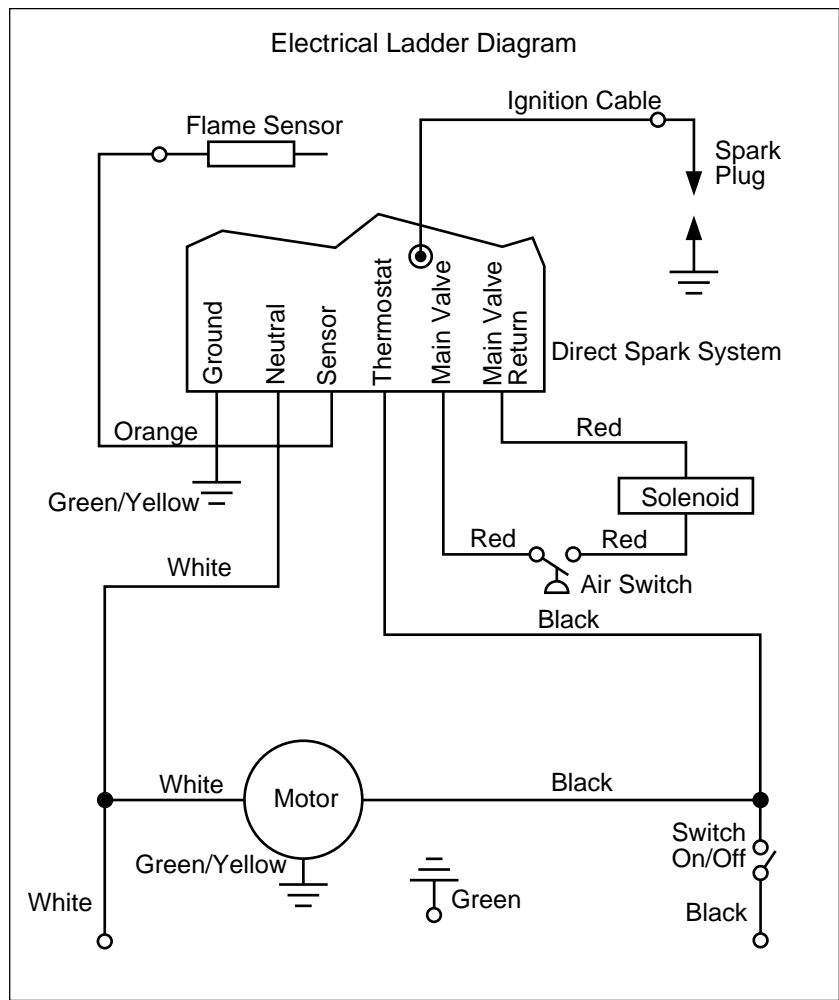

WIRING DIAGRAMS

150,000 BTU/Hr Model

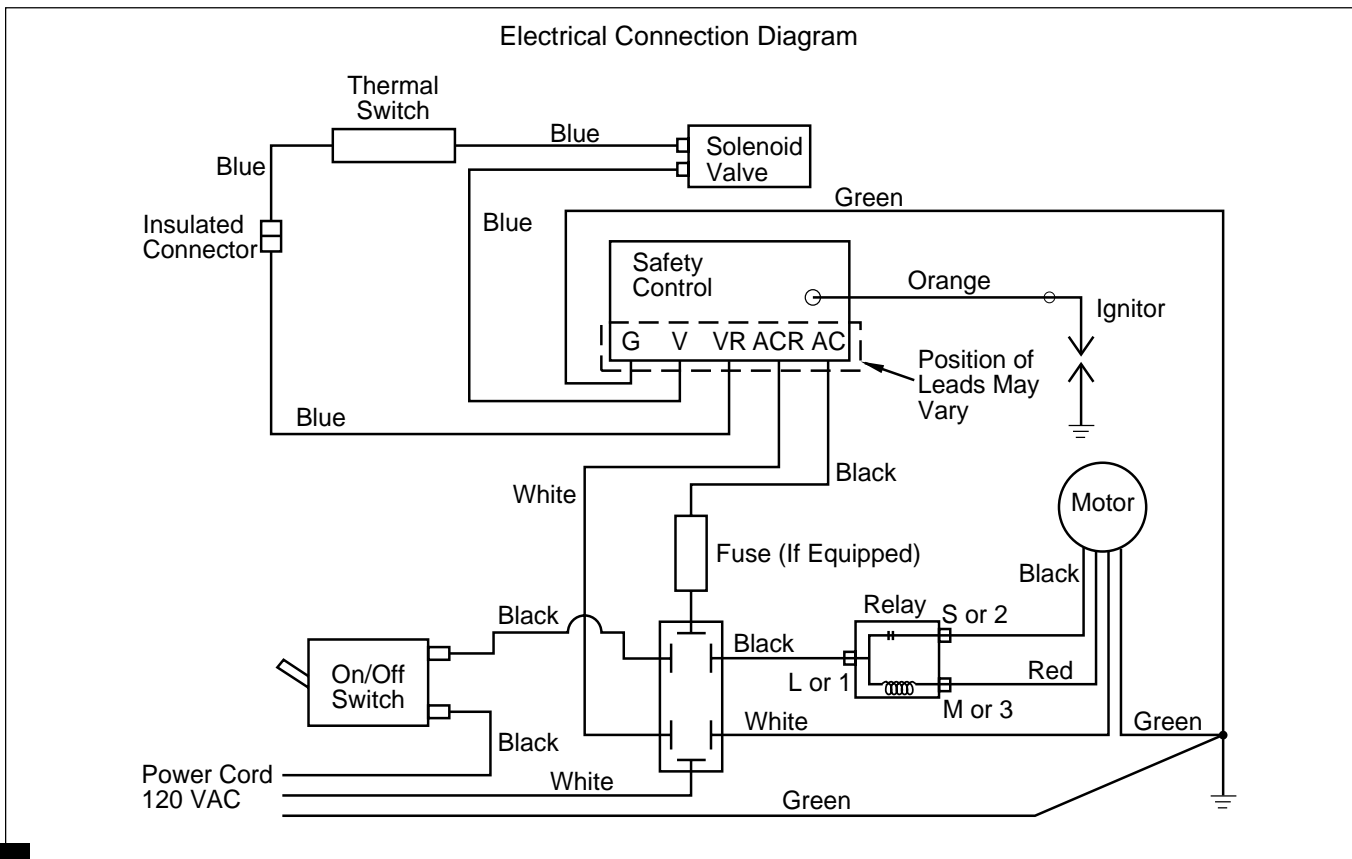
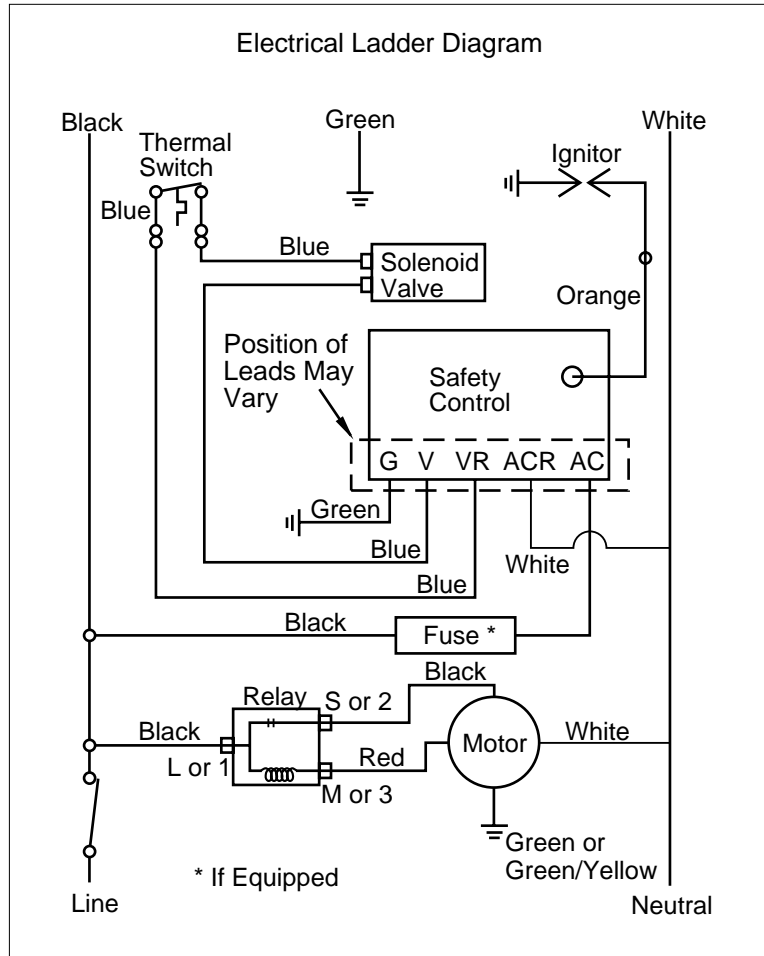

ACCESSORIES

Purchase accessories and parts from your nearest dealer or service center. If your dealer or service center can not supply an accessory or part, either contact your nearest Parts Central (listed in the separate Authorized Service Center booklet) or call DESA International's Parts Department at (502) 781-9600. You can also write to the address listed on the back page of this manual.

TECHNICAL SERVICE

SERVICE PUBLICATIONS

REPLACEMENT PARTS

Hose: LPA1000 - For 80,000 BTU/Hr Model

A 10 foot hose for locating heater further away from propane tank(s).

Regulator: LPA2080 - For 80,000 BTU/Hr Model LPA2100 - For 150,000 BTU/Hr Model

Hose and Regulator Assembly: LPA3010 - For 80,000 BTU/Hr Model LPA3070 - For 150,000 BTU/Hr Model

Fuel Gas Connector: LPA4020 - For All Models

A POL adapter with excess-flow check valve.

Thermostat: HA1210 - For All Models

- Helps economize on fuel
- No installation required
- Plugs into standard 120V outlet

You may have further questions about this heater. If so, contact DESA International's Technical Service Department at 1-800-323-5190.

You can receive an Illustrated Parts List free of charge. Send your request and a self-addressed, stamped envelope to DESA International (address on back page). Be sure to include the heater model number. You can purchase a service manual for \$5. Make check payable to DESA International.

WARNING

Use only original replacement parts. This heater must use design-specific parts. Do not substitute or use generic parts. Improper replacement parts could cause serious or fatal injuries. This will also protect your warranty coverage for parts replaced under warranty.

Parts Under Warranty

Contact authorized dealers of this product. If they can't supply original replacement part(s), either contact your nearest Parts Central or call DESA International's Technical Service Department at 1-800-323-5190. When calling DESA International, have ready:

- your name
- your address
- model number of your heater
- how heater was malfunctioning
- purchase date

In most cases, we will ask you to return the defective part to the factory.

Parts Not Under Warranty

Contact authorized dealers of this product. If they can't supply original replacement part(s), either contact your nearest Parts Central or call DESA International's Parts Department at 1-800-972-7879. When calling DESA International, have ready:

- model number of your heater
- the replacement part number

WARRANTY AND REPAIR SERVICE

KEEP THIS WARRANTY

LIMITED WARRANTY

DESA International warrants this product and any parts thereof, to be free from defects in materials and workmanship for six (6) months from the date of first purchase when operated and maintained in accordance with instructions. This warranty is extended only to the original retail purchaser, when proof of purchase is provided.

This warranty covers only the cost of parts and labor required to restore the product to proper operating condition. Transportation and incidental costs associated with warranty repairs are not reimbursable under this warranty.

Warranty service is available only through authorized dealers and service centers.

This warranty does not cover defects resulting from misuse, abuse, negligence, accidents, lack of proper maintenance, normal wear, alteration, modification, tampering, contaminated fuels, repair using improper parts, or repair by anyone other than an authorized dealer or service center. Routine maintenance is the responsibility of the owner.

THIS EXPRESS WARRANTY IS GIVEN IN LIEU OF ANY OTHER WARRANTY EITHER EXPRESSED OR IMPLIED, INCLUDING WARRANTIES OF MERCHANTABILITY AND FITNESS FOR A PARTICULAR PURPOSE.

DESA International assumes no responsibility for indirect, incidental or consequential damages. Some states do not allow the exclusion or limitation of incidental or consequential damages, or limitations or exclusions may not apply to you. This Limited Warranty gives you specific legal rights and you may also have other rights which vary from state to state.

We reserve the right to amend these specifications at any time without notice. The only warranty applicable is our standard written warranty. We make no other warranty, expressed or implied.

WARRANTY SERVICE

Should your heater require service, return it to your nearest authorized service center. Proof of purchase must be presented with the heater. The heater will be inspected. A defect may be caused by faulty materials or workmanship. If so, DESA International will repair or replace the heater without charge.

REPAIR SERVICE

Return your heater to your nearest authorized service center. Repairs not covered by the warranty will be billed at standard prices. Each Service Center is independently owned and operated. We reserve the right to amend these specifications at any time without notice.

Model _____

Serial No. _____

Date of Purchase _____

DESA
INTERNATIONAL

2701 Industrial Drive
P.O. Box 90004
Bowling Green, KY 42102-9004

For information, write: DESA International, P.O. Box 90004
Bowling Green, Kentucky 42102-9004 ATTN: Customer Service Department
When writing, always include model number and serial number.

099162-01
Rev. F
10/94