

**DB-87040/DB-87060**

**4/6 Axes Motion Daughter Board**

**User's Manual**

## **Disclaimers**

The information in this manual has been carefully checked and is believed to be accurate. AXIOMTEK Co., Ltd. assumes no responsibility for any infringements of patents or other rights of third parties which may result from its use.

AXIOMTEK assumes no responsibility for any inaccuracies that may be contained in this document. AXIOMTEK makes no commitment to update or to keep current the information contained in this manual.

AXIOMTEK reserves the right to make improvements to this document and/or product at any time and without notice.

No part of this document may be reproduced, stored in a retrieval system, or transmitted, in any form or by any means, electronic, mechanical, photocopying, recording, or otherwise, without the prior written permission of AXIOMTEK Co., Ltd.

**©Copyright 2005 by AXIOMTEK Co., Ltd.**

**All rights reserved.**

**October 2005, Version A1**

**Printed in Taiwan**

## Table of Contents

<b>Chapter 1 Introduction</b> -----	<b>iv</b>
1.1 Specifications.....	1
<b>Chapter 2 Hardware Setting</b> -----	<b>3</b>
2.1 System Connection Diagram.....	3
2.2 HARDWARE LAYOUT .....	3

**This page does not contain any information.**

# Chapter 1

## Introduction

DB-87040 and DB-87060 are a general terminal board for 4 axes and 6 axes motion controls, respectively. They are convenience and efficiency for connecting the 4/6-axes motion control card with external devices such as servo drive, encoder, local I/O and DAC signal. They are also compatible with various types of servo drive by wiring with the servo specified wiring configuration.

### 1.1 Specifications

#### General Specifications

- Dedicated Digital input/output interface for the ASP-52504/52506 4/6 axes motion board  
Connector: 30-pin terminal block  
System I/O Signal: external RDY, STOP, HOM, OT
- Encoder interface for the DASP-52504/52506 motion board  
Connector: 25-pin D-Sub female type  
Signal: 4 axes or 6 axes A/B/Z encoder signal
- Servo /Stepper drive control command and status  
Connector: 4 sets or 6 sets, 25-pin D-Sub male type  
Signal: pulse train or Analog command, control/status

- 4-axes or 6-axes motion control wiring signals

Connector: SCSI-II 100-pin pin type

Signal: 4-axes or 6-axes motion control board signals

### **Dedicated Digital Input and Output**

- D/I Signal: HOME, OT+, OT-, STOP (Emergency Stop)
- D/O Signal: INH (Output Inhibits) and RDY (Servo Ready)
- Operation: DIP switch forced setting or normal
- Input Signal: Opto-isolation low active
- Output Signal: OPEN COLLECTOR

### **General Environment**

- Power: external +24V
- Operating Temperature: 0-60°C
- Storage temp: -20 to 70°C
- Humidity: 0 to 90 non-condensing
- Humidity: 0 to 90%
- Dimensions: 245 mm x 108 mm
- Mechanism: DIN-Rail terminal block

## Chapter 2 Hardware Setting

### 2.1 System Connection Diagram

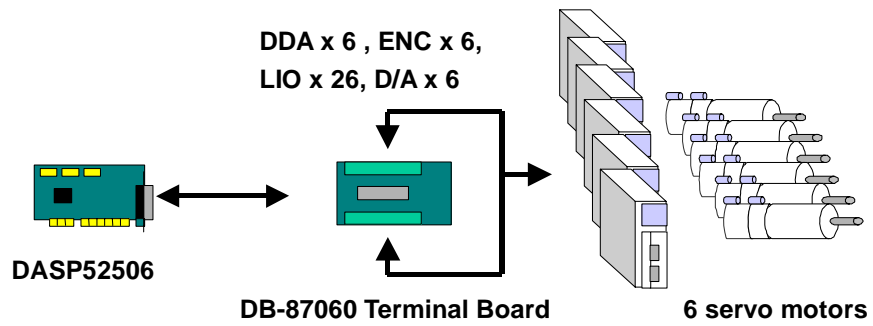

(For Example: DB-87060 Terminal Board)

### 2.2 HARDWARE LAYOUT

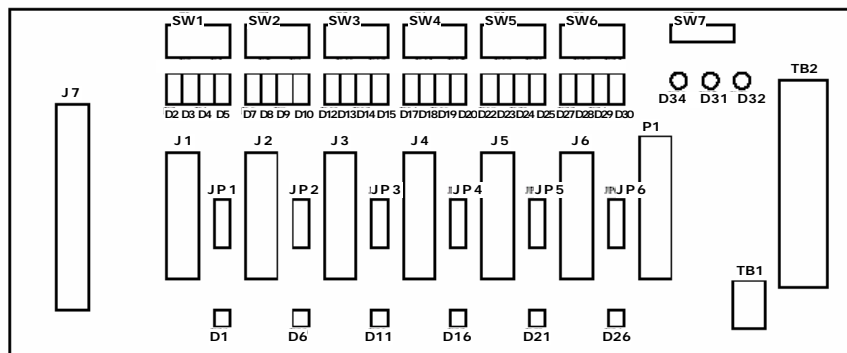

DB-87060 Terminal Board Layout

**(A). Terminal Block - TB1**

2 <b>DGND</b>
1 <b>+24V</b>

Pin 1: Power Ground

Pin 2: +24V Power Input

**(B). Terminal Block – TB2**

29 <b>NC</b>	30 <b>NC</b>
27 <b>GND</b>	28 <b>STOP</b>
25 <b>RDY+</b>	26 <b>RDY-</b>
23 <b>HOM6</b>	24 <b>OT+6</b>
21 <b>GND</b>	22 <b>OT-6</b>
19 <b>HOM5</b>	20 <b>OT+5</b>
17 <b>GND</b>	18 <b>OT-5</b>
15 <b>HOM4</b>	16 <b>OT+4</b>
13 <b>GND</b>	14 <b>OT-4</b>



11 <b>HOM3</b>	12 <b>OT+3</b>
9 <b>GND</b>	10 <b>OT-3</b>
7 <b>HOM2</b>	8 <b>OT+2</b>
5 <b>GND</b>	6 <b>OT-2</b>
3 <b>HOM1</b>	4 <b>OT+1</b>
1 <b>GND</b>	2 <b>OT-1</b>

RDY+, RDY-: Output Servo Ready Signal

STOP: Emergency Stop Input Signal

OT+n, OT-n: Input Inhibit Signal from the *n*th Axes

HOM*n*: Input Home Signal from the *n*th Axes

**Wiring Diagram:**

HOME, OT+, OT- (digital input of each axis) and STOP

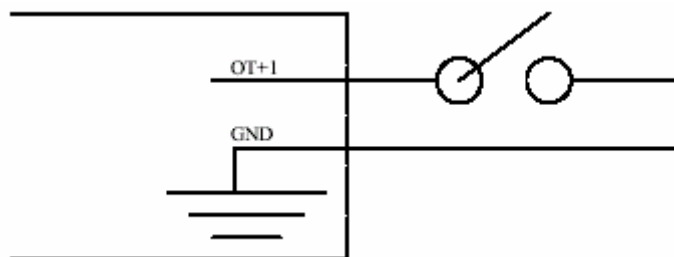

**RDY digital output**

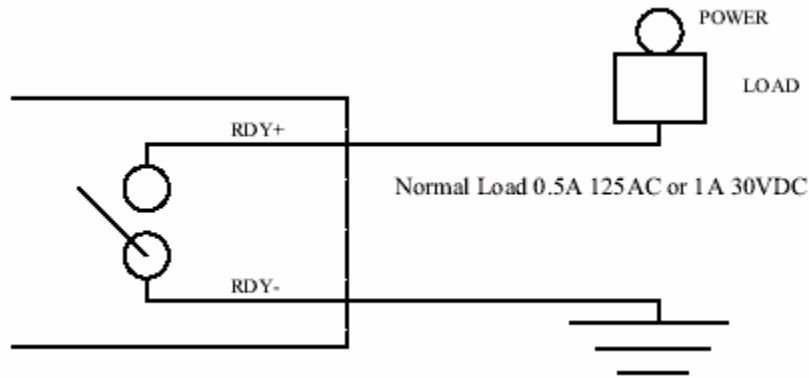

**(C). Switch – SW1, SW2, SW3, SW4, SW5, SW6**

Pin	1	2	3	4	5
Definition	HOME	OT+	OT-	MODE	INH
Default	OFF	OFF	OFF	OFF	OFF

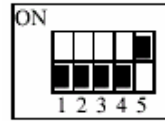

- HOME : Parallel connection with TB1. HOME should be set OFF when it connected with the external HOME Sensor. The Dip Switch is simulated as the external Home Sensor when the actual external Home Sensor is not connected. Set the Dip Switch ON indicates the simulated Home Sensor is enabled and OFF indicates disable.
- OT+ : Parallel connection with TB1. OT+ should be set OFF when it connected with the external OT+ Sensor. The Dip Switch is simulated as the external OT+ Sensor when the actual external OT+ Sensor is not connected. Set the Dip Switch ON indicates

the simulated OT+ Sensor is enabled and OFF indicates disable.

- OT- : Parallel connection with TB1. OT- should be set OFF when it connected with the external OT- Sensor. The Dip Switch is simulated as the external OT+ Sensor when the actual external OT- Sensor is not connected. Set the Dip Switch ON indicates the simulated OT- Sensor is enabled and OFF indicates disable.
- MODE : Reserved (Not Available)
- INH : Parallel connection with Connector J1, J2, J3, J4, J5 and J6 of each driver. INH should be set OFF if the Servo On signal is provided by software. It should be set ON if the Servo On signal is provided by hardware device. The Dip Switch is simulated as the function of Servo On. Set the Dip Switch ON indicates the simulated Servo On signal is enabled and OFF indicates disable.

**(D). Indicator**

<b>Axis 1</b>	Indicator	D2	D3	D4	D5	D1
	Definition	HOME1	OT+1	OT-1	INH1	S_RDY1
<b>Axis 2</b>	Indicator	D7	D8	D9	D10	D6
	Definition	HOME2	OT+2	OT-2	INH2	S_RDY2
<b>Axis 3</b>	Indicator	D12	D13	D14	D15	D11
	Definition	HOME3	OT+3	OT-3	INH3	S_RDY3
<b>Axis 4</b>	Indicator	D17	D18	D19	D20	D16
	Definition	HOME4	OT+4	OT-4	INH4	S_RDY4
<b>Axis 5</b>	Indicator	D22	D23	D24	D25	D21
	Definition	HOME5	OT+5	OT-5	INH5	S_RDY5
<b>Axis 6</b>	Indicator	D27	D28	D29	D30	D26
	Definition	HOME6	OT+6	OT-6	INH6	S_RDY6
<b>Others</b>	Indicator	D34	D31	D32		
	Definition	+24V	P_RDY	STOP		

- HOME: ON→ HOME signal input, OFF→ HOME finish.
- OT+: ON→ OT+ signal input, OFF→ OT+ finish.
- OT-: ON→ OT- signal input, OFF→ OT- finish.
- INH: ON→ Servo On, OFF→ Servo Off.
- +24V: External +24V power source.
- STOP: ON→ STOP signal input, OFF→ STOP signal finish.
- P\_RDY: ON( P\_RDY Active, PDY+ and PDY- is shorted, OFF( P\_RDY finish.
- S\_RDY: Controlled by Servo driver, ON( Servo Ready, OFF( Servo Off.

**(E). Connector – P1**

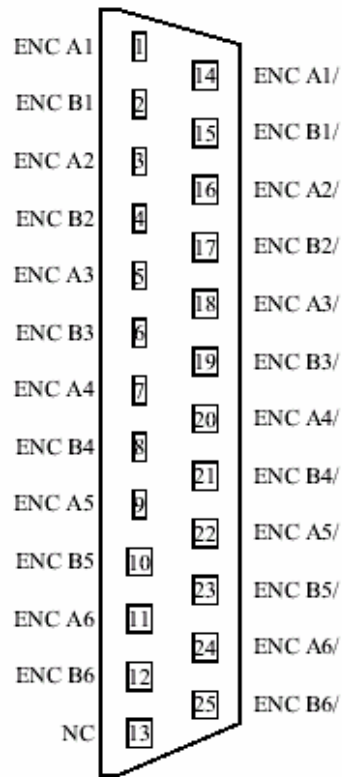

Encoder Input Signal

**(F). Jumper – JP1, JP2, JP3, JP4, JP5, JP6**

**Pins Assignment**

<b>3</b>	Torque Command (T.CMD)
<b>2</b>	DAC Output
<b>1</b>	Velocity Command (V.CMD)

**Function and Configuration**

<b>Jumper</b>	<b>JP1</b>	<b>JP2</b>	<b>JP3</b>	<b>JP4</b>	<b>JP5</b>	<b>JP6</b>
1-2 short	V_CMD1	V_CMD2	V_CMD3	V_CMD4	V_CMD5	V_CMD6
2-3 short	T_CMD1	T_CMD2	T_CMD3	T_CMD4	T_CMD5	T_CMD6

JP1~JP6 do not setting if the servo driver is a Pulse type

**(G). Driver Connector – J1, J2, J3, J4, J5, J6**

No.	Definition	Function
1	Z+	Differential signal of Encoder Phase Z+ Input
2	A+	Differential signal of Encoder Phase A+ Input
3	B+	Differential signal of Encoder Phase B+ Input
4	PULSE+	Differential signal of Encoder Phase PULSE+ Input
5	SIGN+	Differential signal of Encoder Phase SIGN+ Input
6	COM-	Digital Ground Input
7	COM-	Digital Ground Input
8	COM+	+24V Input
9	SERVO_ON	Connect to COM- for Servo ON
10	C_MODE	Reserved
11	AGND	Analog Ground
12	NC	No define
13	FG	Frame Ground
14	Z-	Differential signal of Encoder Phase Z- Input
15	A-	Differential signal of Encoder Phase A- Input
16	B-	Differential signal of Encoder Phase B- Input
17	PULSE-	Differential signal of Encoder Phase PULSE- Input
18	SIGN-	Differential signal of Encoder Phase SIGN- Input
19	S_RDY	Servo Ready Input
20	COM-	Digital Ground Input
21	COM-	Digital Ground Input
22	COM-	Digital Ground Input
23	T_CMD	Torque Command Output
24	V_CMD	Velocity Command Output
25	AGND	Analog Ground

**(H). SCSI-II 100Pin (Pin-Type) – J7**

SCSI II-100PIN CONNECTOR			
Definition	pin	pin	Definition
AGND	1	51	AGND
DAC/D1	2	52	DAC/D4
DAC/D2	3	53	DAC/D5
DAC/D3	4	54	DAC/D6
VCC_OUT(+5V)	5	55	COM-
COM+	6	56	COM-
COM	7	57	E_STOP
COM	8	58	P_RDY
HOME_I1	9	59	HOME_I2
OT+_I1	10	60	OT+_I2
OT-_I1	11	61	OT-_I2
INH_O1	12	62	INH_O2
HOME_I3	13	63	HOME_I4
OT+_I3	14	64	OT+_I4
OT-_I3	15	65	OT-_I4
INH_O3	16	66	INH_O4
HOME_I5	17	67	HOME_I6
OT+_I5	18	68	OT+_I6
OT-_I5	19	69	OT-_I6
INH_O5	20	70	INH_O6
XENC_INA1	21	71	XENC_INA2
~XENC_INA1	22	72	~XENC_INA2
XENC_INB1	23	73	XENC_INB2
~XENC_INB1	24	74	~XENC_INB2
XENC_INC1	25	75	XENC_INC2
~XENC_INC1	26	76	~XENC_INC2
XENC_INA3	27	77	XENC_INA4
~XENC_INA3	28	78	~XENC_INA4
XENC_INB3	29	79	XENC_INB4



<b>SCSI II-100PIN CONNECTOR</b>			
<b>Definition</b>	<b>pin</b>	<b>pin</b>	<b>Definition</b>
~XENC_INB3	30	80	~XENC_INB4
XENC_INC3	31	81	XENC_INC4
~XENC_INC3	32	82	~XENC_INC4
XENC_INA5	33	83	XENC_INA6
~XENC_INA5	34	84	~XENC_INA6
XENC_INB5	35	85	XENC_INB6
~XENC_INB5	36	86	~XENC_INB6
XENC_INC5	37	87	XENC_INC6
~XENC_INC5	38	88	~XENC_INC6
XDDA_OUTA1	39	89	XDDA_OUTA2
~XDDA_OUTA1	40	90	~XDDA_OUTA2
XDDA_OUTB1	41	91	XDDA_OUTB2
~XDDA_OUTB1	42	92	~XDDA_OUTB2
XDDA_OUTA3	43	93	XDDA_OUTA4
~XDDA_OUTA3	44	94	~XDDA_OUTA4
XDDA_OUTB3	45	95	XDDA_OUTB4
~XDDA_OUTB3	46	96	~XDDA_OUTB4
XDDA_OUTA5	47	97	XDDA_OUTA6
~XDDA_OUTA5	48	98	~XDDA_OUTA6
XDDA_OUTB5	49	99	XDDA_OUTB6
~XDDA_OUTB5	50	100	~XDDA_OUTB6

\*J7 connect to DASP-52504 or DASP-52506 axes control card