

# VEGA



Football

Rugby

**3412.514.02**

Version 5.00











Edition August 2008

## CAUTION

- ❑ **Protect the equipment against splashing, rain and excessive sun rays.**
- ❑ **Never use the device if it is damaged or insecure.**
- ❑ **Verify the selection of the power distribution.**
- ❑ **Do not open the case; there is nothing that needs servicing inside it. Nevertheless, if the case must be opened, you must call for some qualified personnel. The power supply cable must be disconnected before opening the case.**
- ❑ **The information contained within this document may be modified without warning.**
- ❑ **Swiss Timing LTD cannot be held responsible for errors within this document nor for any subsequent nor consequential damages (including loss of profit) arising from its provision, nor performance or use of products described herein, which will be covered by another guarantee, contract or other legal document.**



**This symbol indicates that this product should not be disposed with household waste. It has to be returned to a local authorized collection system. By following this procedure you will contribute to the protection of the environment and human health. The recycling of the materials will help to conserve natural resources (valid in the EU member states and in any countries with corresponding legislation).**

<b>1</b>	<b>INTRODUCTION .....</b>	<b>1</b>
1.1	Installation .....	1
1.2	Set-up .....	1
1.3	Keyboard .....	2
<b>2</b>	<b>MAIN MENU .....</b>	<b>3</b>
<b>3</b>	 <b>[CONSOLE SET] PARAMETERIZATION OF THE CONSOLE .....</b>	<b>4</b>
3.1	Ext Start/Stop – External Start/Stop .....	4
3.2	Test .....	4
3.3	Advance .....	4
3.3.1	<i>Languages</i> .....	4
3.3.2	<i>Bluetooth configuration</i> .....	4
3.4	 Name – Teams names, Players numbers, Players names .....	5
3.4.1	<i>Sending the teams names</i> .....	5
3.4.2	<i>Sending the players names</i> .....	5
3.4.3	<i>Instant sending of the names</i> .....	5
3.4.4	<i>Introduction of players names and numbers</i> .....	5
3.5	 Update the software .....	6
<b>4</b>	 <b>[TIME] DAY TIME .....</b>	<b>7</b>
<b>5</b>	 <b>[SELECT] GAME PARAMETERS .....</b>	<b>8</b>
5.1	 [Settings] Choose the settings for a sport .....	8
5.2	 [Save] Save the sport settings .....	11
5.3	 [Default] Change the standard settings for a sport .....	11
5.4	 [All Def & Save] Reset the standard settings for all sports .....	11
<b>6</b>	 <b>[PLAY] MATCH .....</b>	<b>12</b>
6.1	Sports with game time .....	13
6.1.1	<i>Start the period</i> .....	13
6.1.2	<i>Modification of the scores</i> .....	13
6.1.3	<i>Modification of the period</i> .....	14
6.1.4	<i>Modification of game time during a game</i> .....	14
6.1.5	<i>End of a period</i> .....	15
6.1.6	<i>Pause</i> .....	15
6.1.7	<i>End of game</i> .....	15
<b>7</b>	<b>DEFAULT VALUES .....</b>	<b>16</b>
<b>8</b>	<b>CONNECTION OF THE CONSOLE .....</b>	<b>17</b>



## 1 INTRODUCTION

Swiss Timing offers a large selection of scoreboards of the *VEGA* range, which are suitable for all external sports stadium. The selection of the scoreboard can be done from one ergonomic console. The keyboard of the console has partially alphanumeric and functional keys. This makes the use for the operator comfortable. This console can also be used with the *SATURN* and *ORION* display boards.

This manual is valid for the version of the software mentioned on the title page. When you switch on, you will see the version on the display.

Some peripheral devices complete the equipment of the *VEGA* scoreboard, for example:

- Bluetooth wireless transmission.
- External Start/Stop for all sports with game time

### 1.1 Installation

See installation manual 3412.515.

### 1.2 Set-up









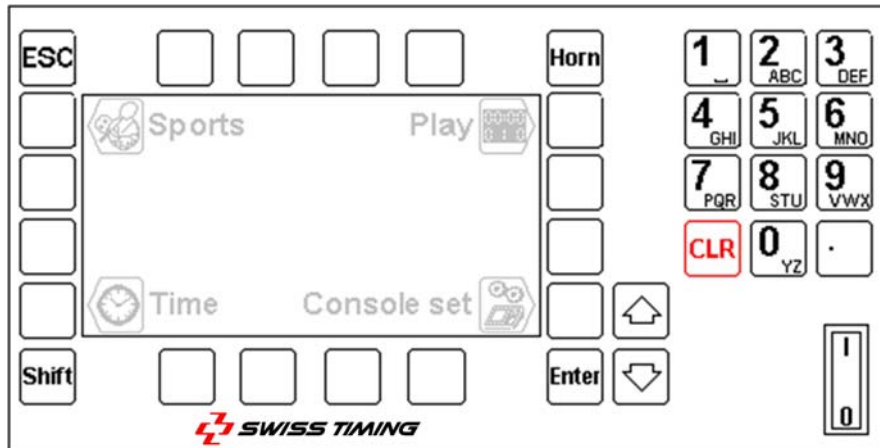

Before you connect the scoreboard and the console to the power supply, please ensure the power and the information cables are installed as per installation manual. Switch on the console at the rear back.

### 1.3 Keyboard

The keyboard consists of three types of keys:

- The alphanumeric keys.
- The keys with one function.
- The keys with more functions.

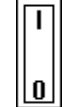

- |   |   |   |  |
|---|---|---|--|
|   | Escapes the function or the menu without validating the possible modifications (ESCAPE) |   | Manual horn (scoreboard)   |
|  | Chooses the second function on the key (Shift + key)                                    |  | Confirms the application or the action.  |
|  | Moves the cursor up   |  | Function key relating to the image shown on its side on the screen                 |
|  | Moves the cursor down   |  | Clears the current operation or clears the whole scoreboard when in the main menu. |
|  | Alphanumeric keyboard   |  | Switch Start/Stop<br>0 = Stop<br>I = Start   |
|  |   |   |  |

## 2 MAIN MENU

When you switch on, the main menu appears. It shows the selected sport, the time and date, as well as the main menus:

Console set	refer to chapter: 3
Time	refer to chapter: 4
Select	refer to chapter: 5
Play	refer to chapter: 6

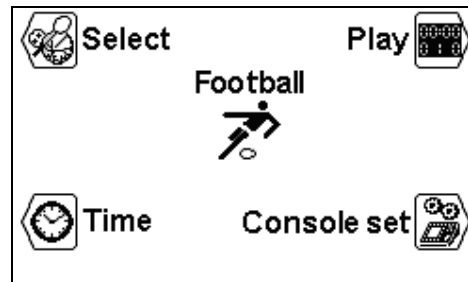

To choose one of the menus, press one of the keys with the function image.



### [CONSOLE SET] PARAMETERIZATION OF THE CONSOLE

In this menu you can introduce the different settings of the console.



### [TIME] DAY TIME

In this menu you can set date and day time.



### [SELECT] GAME PARAMETERS

In this menu you can select and save the different sport settings.



### [PLAY] MATCH

In this menu you can start a game.

### 3 [CONSOLE SET] PARAMETERIZATION OF THE CONSOLE

In this menu you can configure the different settings of the console. The top of the screen shows the console's software version.

#### 3.1 Ext Start/Stop – External Start/Stop

You have the possibility to connect an external Start/Stop switch to the Jack plug socket situated at the back of the console. Press the function key depending on the application:

- external Start/Stop extern** switched on.
- external Start/Stop extern** switched off (in this mode, a possible external Start/Stop will only drive the ball possession time (shot clock).

#### 3.2 Test

This function sends a test program to the scoreboard and appears on the display of the console. Press the  key to exit the program.

#### 3.3 Advance

This menu allows the management of the language and the Bluetooth link.

##### 3.3.1 Languages

Select menu language (English, Français, Italiano) pressing the function key.

##### 3.3.2 Bluetooth configuration

The "BT" key allows you to select the Bluetooth scoreboards who have to be wireless connected to this console. Do not use this function if your console is not equipped with the internal bi-directional Bluetooth option.

If you want to change the Bluetooth scoreboards connected to this console:

- Power ON all the requested scoreboards.
- On the console, press the "Yes" key.

#### **NEVER SWITCH OFF THE CONSOLE DURING THE CONFIGURATION !**

- Wait until question is displayed.
- The name of the scoreboard is display. Answer "**Yes**" if the founded Scoreboard has to be connected on the console, answer "**No**" to disconnect this scoreboard or "**V**" to not change the configuration of this scoreboard.
- Repeat the precedent point for each scoreboard founded.
- Then the software automatically go back in the "Advance" menu. Press twice the "ESC" key to go back in the main menu.
- The day time must be displayed on the scoreboard (if not, wait about a minute for Bluetooth connection).

Note: only Bluetooth scoreboard with the **same password** can be configured.



### 3.4 Name – Teams names, Players numbers, Players names

This menu allows the management of the teams names as well as the players names and numbers.

#### 3.4.1 *Sending the teams names*

If the "Send Team" box is ticked () , the teams names will be sent when entering the match (the message "Wait for data transmission" will appear on the screen during a few seconds).



Tick this box only if you have the optional module "Team Name".

#### 3.4.2 *Sending the players names*

If the "Send Player" box is ticked () , the players names will be sent when entering the match (the message "Wait for data transmission" will appear on the screen during a few seconds).

Tick this box only if you have the optional modules "Players Names".



#### 3.4.3 *Instant sending of the names*







Press key  to instantly send the teams and players names to the board. During the sending, the text "Sending..." is displayed on the bottom of the screen. Press the  key to Stop the transmission.

#### 3.4.4 *Introduction of players names and numbers*

Using the "Modify Visitors" and "Modify Home" keys, you can introduce the team name as well as players names and numbers, for the visitors and local team.

In this screen:

- The "Team" key allows the edition of the team's name\*.
- The  and  keys allow to choose one of the players to be modified (N = 1 to 16).
- When you first press on the "N Num Name" key, you can modify the player's number.
- After confirmation of the player's number, if you press a second time on the "N Num Name" key, you will be able to edit the player's name. After validation, the key automatically goes to the next player (N = 1 to 16).

\*: The  and  keys allow to move the cursor.  
 The  key allow to erase the letter preceding the cursor.  
 The  and  keys allow to introduce a letter or a number, the same way as for a mobile phone (by pressing successively on the same key).  
 The  key allows to validate the modifications.  
 The  key allows to cancel the modifications.

It is possible to have up to 16 players per team.

### 3.5 Update the software

The VEGA line allows the download of a new software version in case there are rule changes in the different sports. Follow the procedure displayed on the screen.

#### Operating of the console:

- Connect the console to the serial port RS232 of the computer (Cable Sub-D 9 poles male-female pin to pin, null modem [article ST No. 9051.1307]).
- Switch on the console.
- Select menu  [Console set].

Press function key . The screen shows the Swiss Timing logo, as well as the actual software version installed.

Press function key  and follow the instructions:

#### **Firmware upload**

Actual version: x.xx

- 1) Connect serial cable
- 2) Press Program Flash on PC
- 3) When completed, turn power OFF and ON

#### Operating of the computer

- Load the FlashSimple program (available on our internet site) and start.
- Press on the “Flash” menu then “Setting” and introduce following values (only for the first use):
  - **H8S/2134F** for Device name
  - **Direct Connection** for Interface name
  - **Port com: X** (according to your computer’s serial port)
  - **Baud rate 9600**
  - **USER mode****Press OK to confirm the parameters.**
- Press on the “Browse” button and download the software (Ex. OMEGA455.fpr)
- Press on the “FLASH program” button and wait for the loading of the software to be finished; **the message “The device was successfully programmed” must appear.** This operation lasts for about 4 minutes.
- When loading is finished, switch the console off, then turn it on again, and check the update version (Ex. Ver 5.00).
- Press the Select button.
- **Press on “All def. & Save” button and validate by pressing Yes in order to initialize the console with the factory values.**

This last operation will erase your specific parameters, but it is essential to keep the new software version in correct working order.

## 4 [TIME] DAY TIME

This menu allows you to introduce the date and day time. Only the day time can be transmitted to a *VEGA* scoreboard. Select the needed function key:



**For the selection of the date**



**For the selection of the hours**







**For the selection of the month**



**For the selection of the minutes**



**For the selection of the year**

To modify the value, use the alphanumeric keyboard or the keys  (plus 1) and  (minus 1), then press the  key to confirm the entry. To go back to the initial value, press on the  key instead of the  key. Repeat this procedure until all the values match your requirements.



**The synchronization of the clock must be done at 0 second by pressing the  key in the selection menu.**

The display of the day time is automatically done when in the main menu of the console.

- **An internal battery allows to keep the exact time and date during 30 days after the last switch off.**
- **The parameters of the console and sports always remain in the memory (not limited in time).**



## 5 [SELECT] GAME PARAMETERS

The selection and back up of the various games parameters (duration of the period, horn, direction of clock counting) is done in this menu.

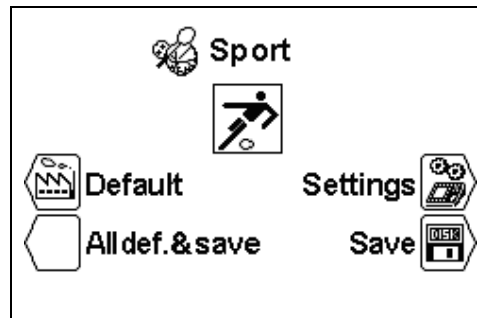
Choose the required sport with the  and  keys. The scrolling is bigger than the size of the display. Therefore, if you press on the  key from the position Basket, other sports will also be displayed.



### 5.1 [Settings] Choose the settings for a sport



When you have selected the desired sport, press on the  key [Settings] to change the parameters. Use the  and  keys to see all the parameters.

- According to the selected sport, some parameters cannot be programmed.
- Each sport memorizes its specific parameters.

 [Number period]  
Number of match period. The actual number of periods is displayed on the right followed by the number of extra periods [EP for Extra Period].

 [Setting period & Pause]  
Modification of the game times of the several periods, the number of extra periods and duration of times out.

[Period]

Use the keys  (plus 1) and  (minus 1) to read the values of the several periods.

[Min. xx] Value of the several periods in minutes.

[Sec. xx] Value of the several periods in seconds.

[Extra Period x] Selection of the number of extra periods.











[Pause] Introduction of the value of the two possible times out, following the same procedure as for the duration of the periods.

The AUTO box allow to choose when the countdown of the pause must start:

At the end of the period (for basket for example).

At the moment of the  key is pressed (when the last player go off the ice in hockey for example).

[Stop Time clock]  The play time is stopped at the end of the period.  
 The play time continue at the end of the period.

- 
-  [Total time]  The time of the first period is added to the time of the second period.  
The time of the first extra period starts at 0.00  
The time of the first extra period is added to the time of the second extra period.  
 All the period start at 0.00.
-  [Count up]  
Changes the way of counting from ascending [Count up] into descending  [Count down].
-  [Visual 1/10]  
The tenth of a second is displayed during the last minute of the descending mode.
-  [Key +2 +3]  
Displays the keys  and  in the menu [Play]. These keys allow to increase the score of 2 or 3 points in one function only.
-  [Shot clock]  
Selection menu of the ball possession timers' parameters.  
 [Shot clock]  Possession timers connected.  
 Possession timers not connected.  
 [Value in Seconds] Duration of the possession in seconds.  
 [No stop]  Does not stop the playtime when the possession time reaches 0.  
 Automatically stops the game time when the possession time reaches 0.  
 [Horn duration] Horn duration for the possession timers (introduce 0 if you do not wish a horn at the end of possession time).
-  [Setup Time Out]  
Selection menu of the time outs parameters.  
 [Time Out on Clock]  The time out is displayed instead of the game time.  
 The time out is displayed on the extra module.  
 [Number Time out] Number of authorized times out (per period or per match)  
 [Sec. Time Out] Duration of the time out in seconds.
-  [Team Fouls]  
Gives the quantity of the maximum authorized fouls per team for a period or for the match. An erasing message comes on before the start of the new period.



**[Ad. Fouls/Score]**

Activates the function of the personal fouls, penalties and goals scored by player.

[Fouls Score]  [Fouls] If the box is ticked () , the player's number is requested at the introduction of a foul. Depending on the sport, you must activate this box if you have either a 909, 919 or 929 board.

[Score] If the box is ticked () , the player's number is requested at the introduction of a goal. Depending on the sport, you must activate this box if you have either a 919 or 929 board.

[Player Fouls x] Maximum quantity of fouls per player.

[Fouls time] If the box is ticked () , it is possible to give the expulsion times. Depending on the sport, tick this box if you have a 908 (or number above) board.

[Select expulsion] Selection of the expulsion (1 to 6)

Use the keys  (plus 1) and  (minus 1) to read the values of each expulsion.

Note:

- **The duration of expulsion 6 will not be numerically displayed on the board but will be indicated by a red luminous dot** (usually used in ice hockey for the 10 minutes expulsion).

[Minutes xx] Minutes value of the expulsion duration.

[Seconds xx] Seconds value of the expulsion duration.

[Clear All] Clears [Fouls Score] and [Fouls time].



**[Setting Horn]**

Selection and duration of the horn at the end of a period, pause and timeout.

[Period: x] Duration in seconds of the horn (on the board) at the end of each period (introduce 0 if no horn is wished at the end of each period).

[10 Sec] If the box is ticked () ,the horn will be activated for one second, 10 second before the end of each timeout.

[Pause & Timeout: x] Duration in seconds of the horn (on the board) at the end of each pause and each timeout.

[Pause] If the box is ticked () , the horn will be activated at the end of each pause.

[Timeout] If the box is ticked () ,the horn will be activated at the end of each timeout.

---

## 5.2 [Save] Save the sport settings

The last modifications of parameters in the several sports are saved in the console. A confirmation message is displayed before the backup.

## 5.3 [Default] Change the standard settings for a sport

Downloads the standard settings for the selected sport. This operation does not save those values in the memory. If you wish to use these parameters for the next competitions, you must save the values as described in the above chapter.



## 5.4 [All Def & Save] Reset the standard settings for all sports

Downloads all the parameters of each sport and saves them in the memory. This function downloads the standard settings of Swiss Timing (see chapter Standard Settings).

**This function must be done after a firmware upload.**



## 6 [PLAY] MATCH

This menu allows you to start a game. You must first select the sport you want in the menu  [Select].

Arrange the keys  and  on the sport you want and press . The VEGA software is now activated in the main menu and the image of the selected sport is displayed in the middle of the screen.

Press on key  [Play] to start the game. The software first asks you if you wish to continue the previous game or start a new one:

 **Download previous game ?**

Answers  to start a new game.  
 to continue the previous game.

When the switch start/stop is on start:

 **Move switch in off position !**

To continue put the switch start/stop on STOP.

Depending on the chosen settings, the console shows the values of the first period.

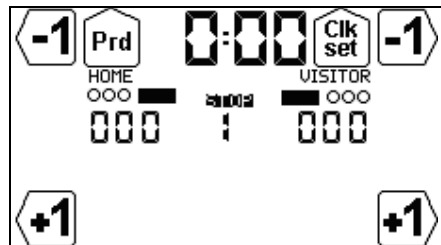



## 6.1 Sports with game time

The display is split in three parts:

A. The general display with regulation of Game Time:

<u>Display</u> 	<u>Description</u> Game Time
	Game Time is stopped Current period
	Modify the period
	Modifying the Game Time during the game

B. Display of the home team (HOME or a name introduced in the console's settings).

C. Display of the visitors team (VISITOR or a name introduced in the console's settings).

<u>Home</u>	<u>Visitors</u>	<u>Description</u>	<u>Home</u>	<u>Visitors</u>	<u>Description</u>
000		Scores			Score +1
					Score -1

### 6.1.1 Start the period

To start the period, put the START/STOP switch on START. The current time starts to count up or down depending on the game settings.

- In START position, the display shows 00
- Turn the switch to STOP, to stop the game time.

- In STOP position, the display shows



### 6.1.2 Modification of the scores

With the help of the function keys you can change the scores.

- Press one of the keys to increase the score.
- Press the key then (it is the key with functionality changed by ) , to reduce the score.

### 6.1.3 Modification of the period

















The period is not automatically increased at the end of a game in order to be able if needed, to modify the score or any other setting before starting the next period. To go to the next period or to modify its value:

- Press  to increase the period by 1.
- Press the key  then  to reduce the period by 1.



See also chapter [6.1.5](#).

### 6.1.4 Modification of game time during a game

When the game time stopped, the key function  becomes active. Now you can modify the current period and introduce a new time. Herewith you do not change the chosen settings for the period. Regarding to the sport, some of the following functions are not available.

- When you press the key , the correction menu appears for the game time.
- Choose the key  [Minutes], to modify the minutes.
  - Introduce the new values and validate with the key .
  - Press  to go out without saving.
- Press the key  [Seconds], to modify the seconds:
  - Introduce the new values and validate with the key .
  - Press , to go out without validating.
- Choose the key  [1/10] to modify the tenth of a second:
  - Introduce the new values and validate with the key .
  - Press  to go out without saving the new value.
- Press the key  [Sec. 24] to modify the possession time:
  - Introduce the new values and validate with the key .
  - Press  to go out without saving the new value.
- Press the key  [HOME] to modify the expulsion time for the local team.
- Press the key  [VISITORS] to modify the expulsion time for the visitors team.
- Press the key  [Pause] to introduce a pause at any time of the match (see chapter [6.1.6](#) for more details).

To go back to the menu [Play]:

- Press the key , to save modifications.
- Press the key , to go out without validating and saving.

### 6.1.5 End of a period



When the period finished, the following display appears:

 Move switch in off position !

Turn the switch on to Stop.







If necessary, adjust score or other events that could have occurred.

Press the key  to go to the next period.

Then, choose whether a time out must be introduced or not. The duration of the two times out available can be set in  [Settings] Choose the settings for a sport. Please note that the count down of a time out will start as soon as key  is pressed (if "AUTO" is not checked in the "Settings") or as soon as the period ended (if "AUTO" is checked). Press  to cancel the count down of a time out.

### 6.1.6 Pause



When the game is stopped and at any time, it is possible to introduce a count down (or pause or time out) of a certain duration. This is very useful for example, to indicate the beginning of the match or the remaining warm-up time.

- Press the key  then  [Pause].
- Select the duration of the pause using  [Minutes] and  [Seconds].
- Validate the duration of the pause by pressing the key . The duration of the pause is now displayed on the screen and on the board.
- At the end of the pause the display and the board show the game time again.
- Press  to cancel a pause in progress.

### 6.1.7 End of game



When the last period is finished, press on the key  ; a screen will ask you if you wish an extra period:

 Extra period ?

Answers  to end the play. The console will show GAME OVER and it will not be possible to start the game time again.  
 to enter the first extra time.

When the console shows GAME OVER or at any other moment, press the  key to exit the game:

 Would you exit the game ?

Answers  to stay in the game.  
 to leave the game.

To start a new game, it is essential to leave the current game first.

## 7 DEFAULT VALUES

Description	Allowed values			Custom
		Football	Rugby	
Number period	1 - 9	2	2	
Setting period pause	1-90-99:59	1 / 45:00	1 / 40:00	
	0 - (10 - period)	2 / 45:00	2 / 40:00	
		EP1 / 15:00	EP1 / 15:00	
		EP2 / 15:00	EP2 / 15:00	
	1-2/0-99	P1 / 15:00	P1 / 5:00	
		P2 / 10:00	P2 / 10:00	
	<input type="checkbox"/> <input checked="" type="checkbox"/>	<input type="checkbox"/>	<input type="checkbox"/>	
Stop time	<input type="checkbox"/> <input checked="" type="checkbox"/>	<input type="checkbox"/>	<input type="checkbox"/>	
Total Time	<input type="checkbox"/> <input checked="" type="checkbox"/>	<input checked="" type="checkbox"/>	<input checked="" type="checkbox"/>	
Count up / down	<input checked="" type="checkbox"/> <input type="checkbox"/>	<input checked="" type="checkbox"/>	<input checked="" type="checkbox"/>	
Display 1/10	<input type="checkbox"/> <input checked="" type="checkbox"/>	<input type="checkbox"/>	<input type="checkbox"/>	

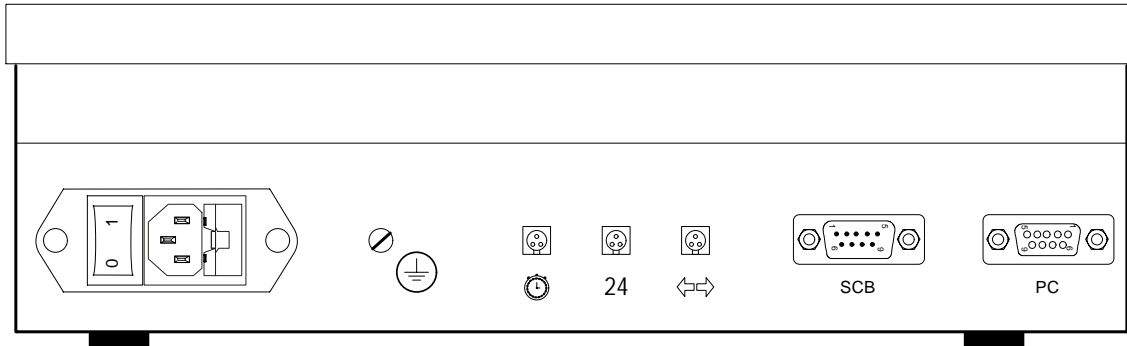

## 8 CONNECTION OF THE CONSOLE

### Console 3400.627

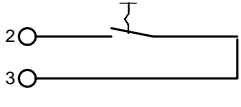
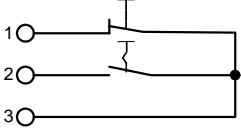

**WARNING:**

- When the console is equipped with the internal BlueTooth option, TX<sub>1</sub> (pin 1 and 2 of Scoreboard connector) IS NOT AVAILABLE.
- When the "SCB on Bluetooth dis." box is checked (in the "Console set" menu) and no internal Bluetooth exist, the pin 1 and 2 of the Scoreboard connector are input instead of output (TX<sub>1</sub>- → RX<sub>1</sub>-, TX<sub>1</sub>+ → RX<sub>1</sub>+).
- It is so recommended to always connect the scoreboards on pin 3 and 4 of the Scoreboard connector.

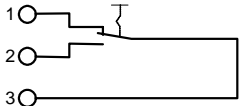
Connector	Pin	Description	
Scoreboard (RS485) SCB	1	TX <sub>1</sub> - (RX <sub>1</sub> -)	
	2	TX <sub>1</sub> + (RX <sub>1</sub> +)	
	3	TX <sub>2</sub> -	
	4	TX <sub>2</sub> +	
Computer (RS232) PC	2	TX	<b>START/STOP connector &amp; external RESET</b>
	3	RX	
	5	GND	
 Start/Stop	1	Not used	
	2	Start/Stop	
	3	Common	
24 Start/Stop + Reset	1	Reset	
	2	Start/Stop	
	3	Common	
 Possession	1	Home	
	2	Visitors	
	3	Common	

Console 3400.624

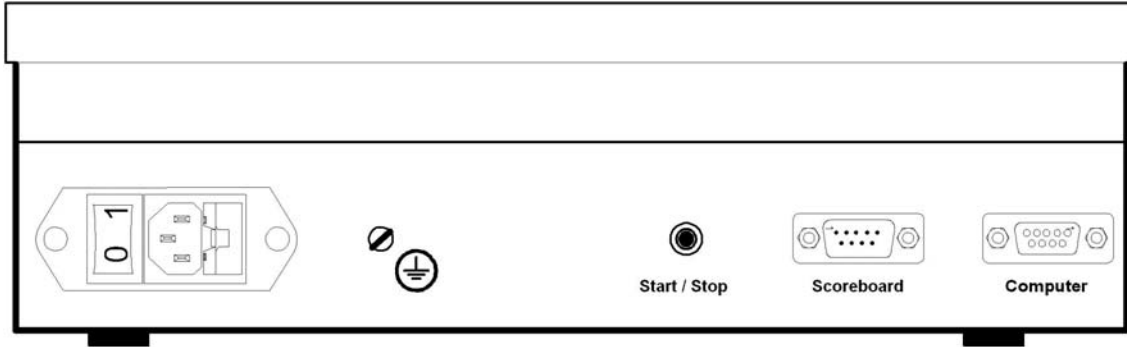

**WARNING:** when the console is equipped with the internal Bluetooth option, TX<sub>1</sub> (pin 1 and 2 of Scoreboard connector) IS NOT AVAILABLE.

Connector	Pin	Description
Scoreboard (RS485)	1	TX <sub>1</sub> -
	2	TX <sub>1</sub> +
	3	TX <sub>2</sub> -
	4	TX <sub>2</sub> +
Computer (RS232)	2	TX
	3	RX
	5	GND

**External Connecteur START/STOP & RESET**

