

TELSTRA SMART TOUCH™

User Manual

Copyright © 2010 ZTE CORPORATION.

All rights reserved.

No part of this publication may be excerpted, reproduced, translated or utilized in any form or by any means, electronic or mechanical, including photocopying and microfilm, without the prior written permission of ZTE Corporation.

The manual is published by ZTE Corporation. We reserve the right to make modifications on print errors or update specifications without prior notice.

Version 1.2 April 2011

Contents

SAFETY	5
DEVICE OVERVIEW.....	8
KEY DEFINITIONS.....	10
INSERT YOUR SIM CARD	11
POWER ON & OFF.....	15
USING THE TOUCH SCREEN CONTROLS	17
THE HOME SCREEN	18
PHONE STATUS AND NOTIFICATION ICONS	22
PHONE CALLS.....	32
MAKING CALLS.....	32
RECEIVING CALLS.....	37
CONTACTS	40
USING THE ON-SCREEN KEYBOARDS	45
MESSAGES	48
SMS AND MMS MESSAGES.....	48
USING MYEMAIL.....	54

GETTING CONNECTED	58
CONNECTING TO THE INTERNET	58
USING THE BROWSER	60
BLUETOOTH	67
CONNECT TO A COMPUTER	70
USING MULTIMEDIA FUNCTIONS	71
CAMERA	71
VIDEO RECORDER	74
FM RADIO	76
MUSIC.....	78
VIDEOS.....	81
GALLERY.....	82
SOUND RECORDER.....	83
GOOGLE APPLICATIONS	84
SIGN IN OR CREATE YOUR GOOGLE ACCOUNT	84
USING GMAIL	84
USING GOOGLE CALENDAR	85
USING GOOGLE TALK.....	86

SETTINGS	88
WIRELESS & NETWORKS SETTINGS	88
SOUND SETTINGS.....	90
DISPLAY SETTINGS	94
LOCATION & SECURITY SETTINGS.....	95
APPLICATION SETTINGS	99
USB SETTINGS.....	99
PRIVACY SETTINGS & FACTORY RESET.....	100
SD CARD, USB MASS STORAGE & PHONE SETTINGS	101
SEARCH SETTINGS	101
LANGUAGE & KEYBOARD SETTINGS.....	101
TEXT TO SPEECH.....	101
DATE & TIME SETTINGS	102
TECHNICAL SPECIFICATIONS:	103
TROUBLESHOOTING AND WARRANTY INFORMATION	104

Safety

General Statement on RF Energy













The phone is a low-power radio transmitter and receiver. When switched on it intermittently transmits radio frequency (RF) energy (radio waves). The transmit power level is optimized for best performance and automatically reduces when there is good quality reception. Maximum power is only used at the edge of network coverage so under most circumstances the power output is very low. Under poor network conditions the phone transmits at a higher power, may get hot and have a shorter battery life.





Specific Absorption Rate (SAR)

The phone is designed not to exceed the limits for exposure to radio waves recommended by the ICNIRP. The limits include safety margins designed to assure the protection of all persons, regardless of age and health.

The guidelines measure the Specific Absorption Rate, or SAR. The SAR limit for mobile devices is 2W/Kg and the highest SAR value for this device is 1.01 W/Kg.

Product Safety Information

	Please read all instructions before use		This device may produce bright or flashing lights
	Do not use while driving		Do not dispose of in fire
	Do not use while re-fuelling		Avoid contact with magnetic media
	Small parts may be a choking hazard		Avoid Extreme Temperatures
	This device may produce loud sounds		Avoid any contact with liquid, keep it dry
	Keep away from pacemakers and other personal medical devices		Only use approved accessories

	<p>Obey warning signs in hospitals and medical facilities</p>		<p>Do not attempt to disassemble</p>
	<p>Switch off when flying</p>		<p>Do not rely on this device for emergency communications</p>
	<p>Switch off in explosive environments</p>		

This device has been certified by the Wi-Fi Alliance.







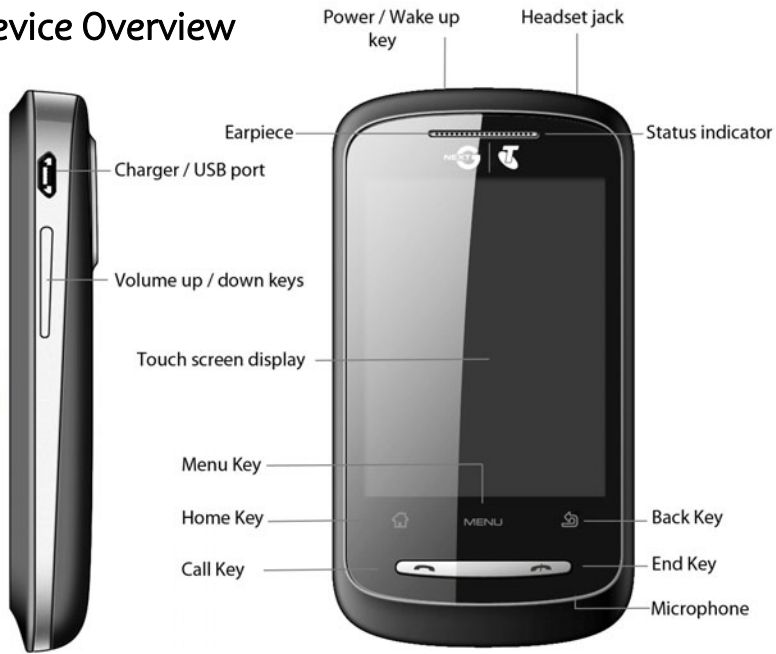

 - microSD™ is a trademark of SD Card Association

Device Overview





Key Definitions

Key	Function
Power Key 	Press to power on your phone. Press to switch to sleep mode. Press to wake up. Hold down for Profile options: Power off, Silent, Vibrate, or Airplane mode.
Home Key 	Tap to return to the Home Screen from any screen. Hold to see the recently used applications.
Menu Key 	Tap to get the options on the current screen. Hold to open the quick search keypad
Back Key 	Tap to go to the previous screen.
Call Key 	Press to open the dial pad to make a call. Press to answer a call.
End Key 	Press to End a call. Hold for Profile options the same as the Power Key.
Volume Keys	Use to control the volume Up and Down

Insert your SIM card

Power off your phone before inserting the SIM, or memory card.

1. Remove the battery cover.

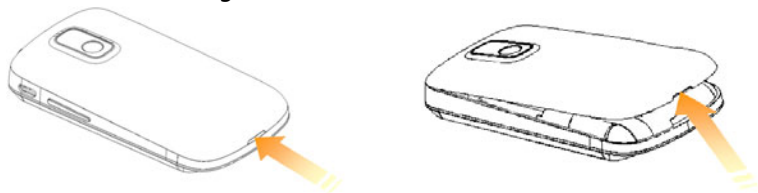

2. Insert your SIM card carefully into the SIM slot as shown. There is a diagram showing the correct orientation of the SIM above the SIM slot.

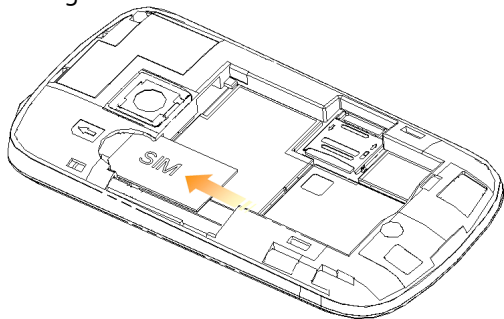

3. The handset supports microSD memory cards up to 32GB. Follow the steps shown below to insert your microSD card into the card holder:

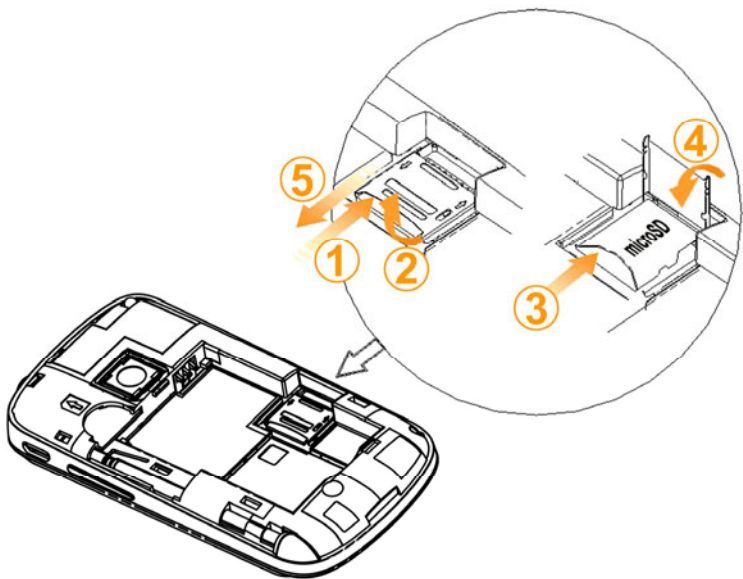

4. Insert the battery as shown with the gold contacts located against the gold springs.

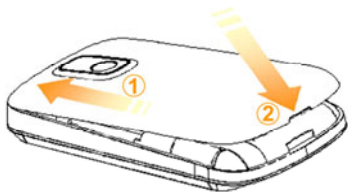
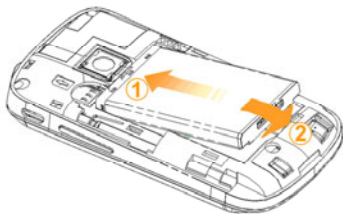

5. Replace the battery cover and press it gently until you hear a click.

Charge the Battery

Charge before initial use. The plug and socket are keyed so they only fit together one way.

- Do NOT use excessive force which may damage the USB port.
- Physical damage to the USB port is NOT covered by warranty.
- The phone can also be charged by connecting it to a computer using the USB lead supplied.
- Disconnect the charger when the battery is fully charged

Insert the charger lead carefully:



Notes:

- If the battery is low, there will be a pop-up message on the screen and the status indicator light will be red.
- When you charge your phone, the indicator light will change according to the battery level:

Status Indicator	Battery level
Red	Less than 10% charge
Orange	More than 10%, but less than 90% charge
Green	More than 90% charge

Power On & Off

1. Make sure that your SIM card and battery are inserted.
2. Press the **Power Key**  to power on your handset.

To power off your handset, press and **hold** the **Power Key** , select **Power off** > **OK**.

Switch your handset to sleep mode

Press the **Power Key** 

Sleep Mode suspends your handset to a low-power state with the display off.

Sleep Mode activates automatically when the handset is idle for a period of time as defined by:

Settings > Sound & display settings > Screen timeout

Wake up from sleep mode

1. Press the **Power Key**  to activate the display.
2. Drag the padlock icon to the right as shown:

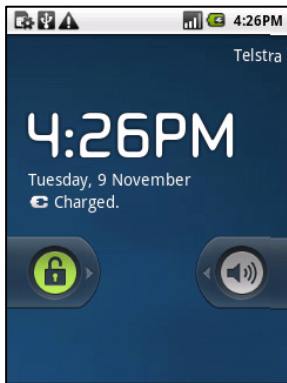

If you have set an unlock pattern for your handset you need to draw the pattern to unlock your screen.

(see *Settings > Location and security > Set unlock pattern*),

Using the Touch Screen Controls

The touch screen controls change dynamically depending on the tasks you are performing:

1. **Tap** buttons or icons to select the function or open applications.
2. **Hold** an item for options related to that function.
3. **Slide up & down** to scroll through lists.
4. **Drag** items to move or perform other operations.
5. **Swipe** sideways to view the extended desktop.



Tip:

In most modes the screen will automatically switch between portrait and landscape mode when changing the orientation of the handset. Some screens assume a preferred orientation and will not change.

The Home Screen

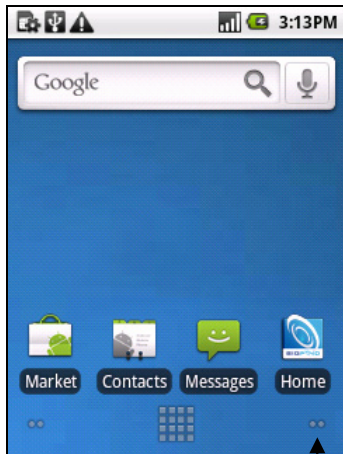

Page indicator

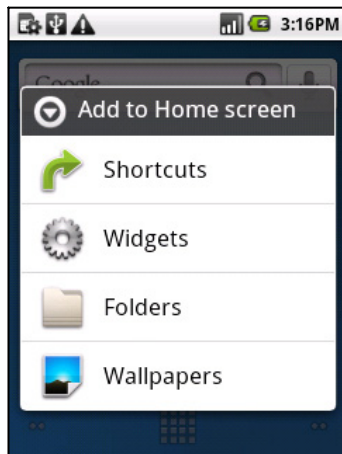

Slide the Home Screen left or right to view additional pages.
Tap and hold to add Shortcuts, Widgets, Folders and Wallpapers.

Home Screen Options:

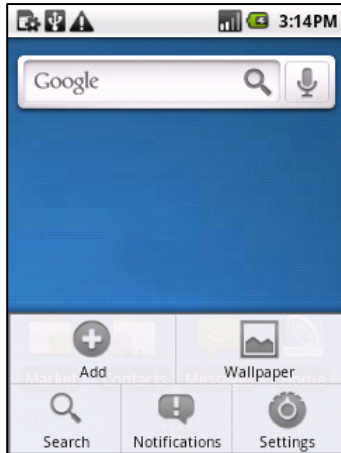



Press the Menu Key to view the Home Screen Options

Customize the Home Screen

Change the wallpaper

1. Tap **Home**  to return to the Home Screen.
2. Tap **Menu** and select **Wallpaper**.
3. Select the wallpaper from **Gallery**, **Live wallpapers**, or **Wallpapers**
4. Tap **Save** or **Set wallpaper**.

Move and Delete a Home Screen item

1. Tap **Home**  to return to the Home Screen.
2. Hold the item and drag to move around the Home Screen.
3. Drag the item to  and release to delete from the Home Screen.

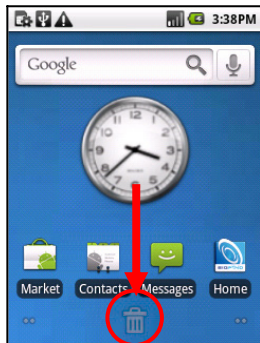





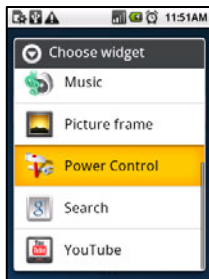
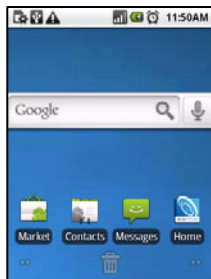









Add items – Example, Add the Power Control Widget













1. Tap **Home**  to return to the Home Screen.
2. Tap and hold the Google Search bar, then move it down the screen.
3. Tap **Menu** and select **Add** or tap and hold on the Home Screen.
4. Tap **Widgets**, scroll down and tap **Power Control** to add

















Phone Status and Notification Icons

Status Icons (Note: data icons can show on the signal strength icon)

	GSM connected		Signal strength
	GPRS in use		Roaming
	EDGE connected		Speaker is mute
	EDGE in use		Microphone is mute
	3G connected		No SIM card installed
	3G in use		GPS is on
	Battery is very low		GPS is connected

	Battery is low		USB is connected
	Battery is full		Connected to a Wi-Fi network
	Battery is charging		Alarm is set
	Vibrate mode		Headset connected
	Airplane mode		Bluetooth is on
	No signal		Speaker is on

Notification Icons

	New Email		New instant message
	New SMS/MMS		Upcoming event
	New voicemail		Song is playing
	Missed call		Downloading data
	Call in progress		Content downloaded
	Call on hold		Uploading data
	Call forwarding on		More (not displayed) notifications
	Problem with SMS/MMS delivery		

The Notifications Panel

The Notifications Panel at the top of the Home Screen shows useful device and status information:

1. Hold the top bar until  appears at the top of the display.
2. Drag the panel downwards to view the notifications:



Tip

You can also open the Notifications Panel from the Home Screen by tapping **Menu > Notifications**.

Multi-Tasking

You can run multiple applications simultaneously. Press the Home key from any application to launch, open or view something else. The original application will be suspended until you return to it.

Applications and Settings

Tap  to access the Applications screen. Scroll down to see more...

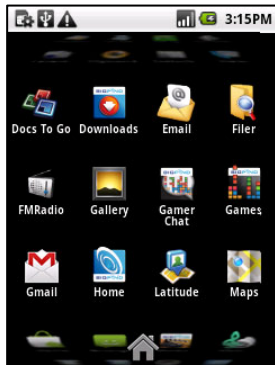
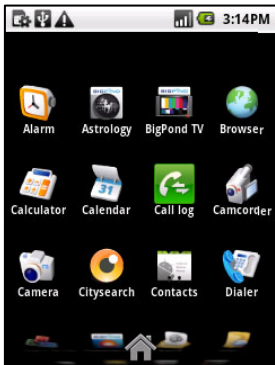

Installing Applications



Tap Market from the Home Screen to download and install applications from the Android Market. Select the item and tap **Install**.

To install non-Market applications you need to go to **Settings > Applications > Unknown sources**.

Uninstall third-party applications

1. Tap Home  > Menu > Settings > Applications > Manage applications
2. Tap on the application you want to remove.
3. Tap **Uninstall**, and tap **OK** to confirm.

Docs To Go



Docs To Go is a free document reader compatible with Microsoft Word, Excel and Adobe PDF. First time use requires registration.

Settings

Tap **Menu > Settings** from the Home Screen to view Settings:

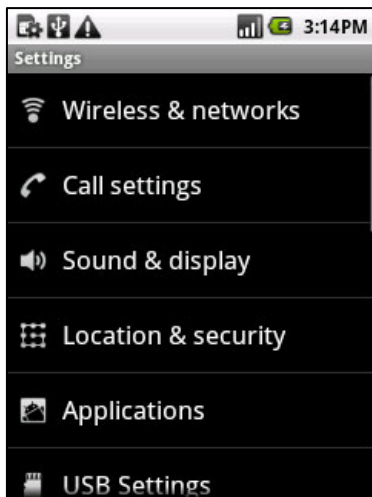

Settings Menu:

Wireless & networks	Manage Wi-Fi, Bluetooth, Mobile networks, Virtual Private Networks & Airplane mode.
Call settings	Set up fixed dial numbers, voicemail, call forwarding, call waiting, and caller ID etc.
Sound & display	Sound levels, ringtones, notifications, vibrate. Display settings, brightness , screen timeout, screen calibration etc.
Location & security	Set a screen unlock pattern, enable the SIM card lock, & manage the credential storage. You can also select the sources for use with My Location .
Applications	Manage applications and installation of new programs.
USB Settings	Configure the PC connection and USB Charging settings.
Account & sync	Manage your account and configure sync settings.

Privacy	Privacy settings such as Location, back up, personal data and perform a Factory Default.
SD card, USB Mass Storage & phone storage	Check available memory on the external memory card (microSD™) and internal storage.
Search	Set the search options, clear search shortcuts.
Language & keyboard	Set the locale (operating system language and region) and text input options.
Accessibility	Manage accessibility options.
Text-to-speech	Configure the text-to-speech settings (if installed)
Date & time	Set the date, time, time zone, and date/time format. Enable automatic time update.
About phone	View the phone status, battery level, and legal information.

Open recently used applications

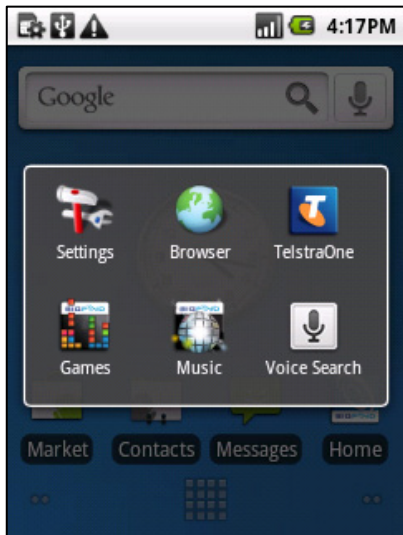

Hold the Home Key  from any screen to view the recently used applications:







Phone Calls

Making Calls

Make a Call from the Dial Pad

1. Press the **Call Key**  from the home screen to open the dial pad.
2. Enter the phone number on the number pad. Tap  to delete numbers entered, hold this key to clear all digits.

Your phone automatically lists matching contacts. Tap  to hide the keypad to see if there are more matching numbers or contacts.

3. Tap  or  to make the call.
4. Press the End Key  to end the call.

Make a Call from Contacts

1. Tap  from the Home Screen. Contacts are displayed in alphabetical order.
2. Slide your finger to scroll through your Contacts list.

3. Tap to select the Contact then tap  to call.





Tips:

Search for a contact by tapping **Menu > Search**.

Press on the right hand side of the Contacts list to use the scroller to scan through your Contacts.

Make a Call from Call History

1. Press the **Call Key**  from the home screen to open the Dial pad.





2. Tap  to open Call History.

3. Scroll and tap the required number. Tap  to start the call

You can also open your Call History by tapping  > **Call log** from the Home Screen.

Make a Call from a Text Message

If a text message contains a phone number you can make a call from the text message:

1. Tap **Home**  >  and tap the thread that contains the phone number to call.
2. Tap the number required then tap  to start the call.
3. Press the End Key  to end the call.

Making a Conference Call

You can make a conference call between yourself and two or more other parties.

1. Call the first number.
2. While you are connected, tap **Menu > Add call**.
3. Call the second number.
4. While you are connected to the second number, tap **Menu > Merge calls**.

5. To add the third party, tap **Menu > Add call**.
6. Dial the number, and when connected, tap **Menu > Merge calls**

Turn the Speaker On/Off (Handsfree)





Tap **Menu > Speaker** during a call. The speakerphone icon  is displayed.

Making an Emergency Call

1. Press the **Call Key**  from any screen to open the Dial pad.
2. Enter the Emergency Number for your location and tap **Call**.

It is possible to dial emergency numbers when the SIM card is not inserted. Tap **Emergency call** to bring up the dial pad and enter the emergency number for your current location.

Making an International Call

1. Press the **Call Key**  to open the Dial pad.
2. Hold down  to enter the “+” symbol for the International Dialling Prefix
3. Enter the full phone number.
4. Tap  or  to make the call.
5. Press the End Key  to end the call.

Mute a Call

During a call tap **Menu > Mute** to mute your microphone. The mute icon  is displayed.

End a Call

During a call tap **Menu > End call** or press the End Key .

Receiving Calls

Answer an Incoming Call

When there is an incoming call, the phone will display the information on the screen.

Drag  to the right to answer the call:

Reject an Incoming Call

Drag  to the left to reject the call.

Place a Call on Hold

During a call tap **Menu** > **Hold** to place the call on hold. The  icon is displayed.

If you are already on a call and accept the new call, the first call will be put on hold automatically. Tap **Swap** to switch between the two calls.

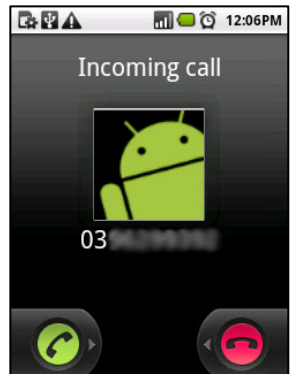

Call Settings

From the **Home Screen** press **Menu > Settings > Call settings**:

Fixed Dialing Numbers	Restrict outgoing calls to a fixed set of numbers. This requires support from your network provider and the SIM PIN2 code.		
Voicemail service	Select a voicemail service provider.		
Voicemail settings	Specify a voicemail number.		
DTMF Tones	Set Long DTMF tones if required eg. Telephone Banking		
GSM/ WCDMA call settings	Call forwarding	Forward incoming calls to another number: Always forward, Forward when busy, Forward when unanswered, or Forward when unreachable.	
	Additional settings Additional settings	Caller ID	Send or block your number in outgoing calls.
		Call waiting	Hear pips to indicate an incoming call while on a call.

Call Barring Settings	Bar various call types. This requires support from your network provider and the barring code.
Speed dial	Set Speed Dial keys. Key 1 is used for Voicemail so cannot be set. To use Speed Dial, press and hold the related number on the dial pad. Eg. Hold the '1' Key to call your Voicemail service.

Insert a Pause or Wait symbol into a phone number

Insert a Pause symbol ';' to add a 2 second delay.



Insert a Wait symbol ';' to wait until the next key press.

- Enter the phone number on the Dial pad.
- Tap and hold the Menu key to bring up the QWERTY keyboard.
- Add the required symbol directly from the keyboard.
- Press Back to return to the dial pad.

Contacts



Contacts can be stored on the (U)SIM card or phone. Contacts stored on the phone provide more fields to enter information such as a photo, home address, email, fax etc.

Tap **Home**  >  to enter the Contacts Screen.

Contacts Screen

Contacts
Gives you access to all contacts on your phone

Call History

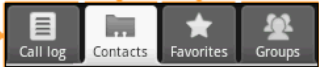



Favorites
Gives you a list of favorite contacts which you can access quickly.

Groups
Lets you assign contacts to groups so you can easily send an SMS, or MMS message to a whole group

Importing / Exporting Contacts

You can import or export contacts to and from your (U)SIM card or microSD™ card.

Tap **Home**  >  to enter the Contacts Screen.

Import / export contacts to the SIM card

1. Tap **Menu** > **Import / Export** from the Contacts Screen.
2. Select to import or export contacts from/to your (U)SIM card.
Your Smart Touch will automatically read the contacts.
3. Select the contacts you want to import/export.
[To import/export all contacts, tap **Menu** > **Select all**.](#)
4. Tap **Done**.

Import / export contacts to and from the memory card

1. Tap **Menu > Import / Export** from the Contacts Screen.
2. Select to import or export contacts from/to microSD™ card.
If you want to import contacts from microSD™ card, you should have vCard files saved in the microSD™ card. If there is more than one vCard file, you need to select the vCard file.
3. Tap **OK**.

Create a New Contact

1. Tap **Menu > New contact** from the Contacts Screen.
2. Select the location to save your contact – If the Contact is stored on the phone (local) then you can add a photo and extra fields such as email, home address etc.
3. Tap the **Given name** field to start entering the Contact details
4. Tap **Done** to save the contact.

Add a Contact to Favourites

1. Tap the contact from your Contacts Screen.
2. Tap the Star symbol  to add to Favorites
3. You can also **Hold** the contact to see the pop up menu
3. Tap **Add to favorites**.

Search Contacts

1. Tap **Menu > Search** from the Contacts Screen.
2. Input the name to search for. The matching contacts will be listed.

Edit a Contact



1. Select the contact from the Contacts Screen.
2. Tap **Menu > Edit contact**.
3. Edit the contact and tap **Done**.

Delete a Contact

1. Select the contact from the Contacts Screen. Tap **Menu** > **Delete contact** > **OK**

You can also **hold** the Contact and select **Delete contact** from the pop-up menu.

Save a Contact from a Message

1. Tap **Home**  >  and tap the thread that contains the phone number you wish to save.
2. Tap **Menu** > **Add to Contacts**
3. Complete the Contact details and tap **Done** to save

Set a dedicated Ringtone

1. Select the contact from the Contacts Screen.
2. Tap **Menu** > **Options** > **Ringtone** to add a unique ringtone.

Using the On-screen Keyboards

To write text in any screen tap the text entry box to open the keyboard. Your preferred settings are remembered each time.

Hold the text entry box to change the **Input method** or select from the Menu button:



Select the input method, Android Keyboard or TouchPal:

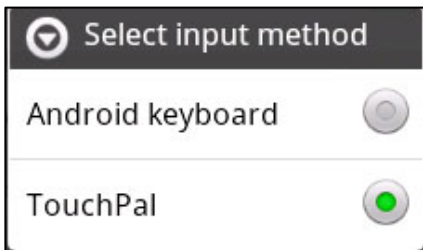

Android Keyboard

The Android keyboard is simple, clear and easy to use:



TouchPal Keyboard

The TouchPal keyboard supports predictive text, multiple languages and three different keyboard layouts. Hold and Swipe the keyboard to select your preferred layout:



Messages





SMS and MMS Messages



Tap **Home**  >  to access SMS and MMS messages.

Unread message(s) will display the  icon in the status bar. Open new messages from the Notifications Panel or the Messaging Screen. Tap the message to read it.

Composing an SMS

1. Tap **Home**  >  > **New message**
2. Tap the **To** field to enter the recipient's number. You can also enter the first letters of their name to display matching **Contacts** and select a recipient from the list or tap  to see your Contacts list.
3. Tap the **Type to compose** field and enter the content of your SMS.
4. Tap **Send** to send your SMS.

Composing an MMS

1. Tap **Home**  >  > **New message**
2. Tap the **To** field to enter the recipient's number. You can also enter the first letters of their name to display matching **Contacts** and select a recipient from the list or tap  to see your Contacts list.
3. Tap **Menu** > **Attach** to add an attachment to your MMS
4. Choose your attachment type from the available list:
5. Tap **Send** to send your MMS.

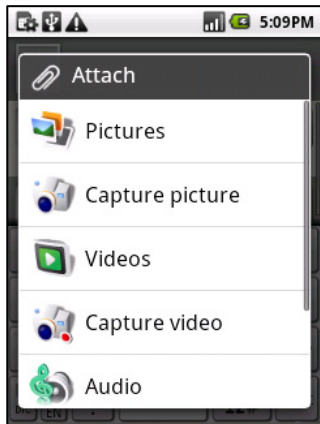



Tips:

Adding or removing the **Subject** or **Attachments** will convert the message from SMS to MMS and vice-versa.

Tap **Menu** > **Add subject** to enter the subject if required.

Tap **Type to compose** to enter text content if required.

Forwarding a Message

Tap and hold the individual message to get further options such as Forward, Delete, View message details etc.

Managing Messages and Messages Threads

SMS and MMS messages sent and received are grouped into message threads in the Messaging screen. Message threads show you the history of messages from a specific contact. Threads are sorted by received time, with the latest one at the top.

Reply to a message

1. Tap the message you want to reply to from the Messaging Screen.
2. Tap **Type to compose** and enter the contents of your message.
3. Tap **Send**.

Access Draft Messages

Tap **Messages > Menu > Draft** to view your draft messages.

Delete a message (thread)

1. Tap **Menu > Delete** threads from the Messaging Screen.
2. Select the messages or threads you want to delete.
3. Tap **OK**.
4. To delete an individual message (not a thread) tap and **hold** the message and select **Delete** from the available options.

You can also delete a message by opening it from the Messaging Screen and tapping **Menu > More > Delete messages**.

Message Settings

From the Messaging Screen Tap **Menu** > **Settings** to configure your message settings:

Storage settings:

- **Delete old messages:** Select to delete old messages as limits are reached.
- **Text message limit:** Set the maximum number of text messages allowed in a single thread.
- **Multimedia message limit:** Set the maximum number of MMS messages allowed in a single thread.

Text message (SMS) settings:

- **Delivery reports:** Request a delivery report for sent SMS messages
- **Manage SIM card messages:** Manage messages on your SIM card.
- **Service Center:** View and edit the service center number

Multimedia message (MMS) settings:

- **Delivery reports:** Request a delivery report for each sent MMS.
- **Read reports:** Request a read report for each sent MMS.
- **Auto retrieve:** Select to retrieve MMS messages automatically.
- **Roaming auto-retrieve:** Retrieve MMS messages automatically when roaming.



Notifications settings:

- **Notifications:** Display message notifications in the status bar.
- **Select ringtone:** Select a ringtone for your incoming messages.
- **Vibrate:** Set vibrate mode when receiving a new message.

Multiple SMS Message Charging:

A standard SMS message can contain up to 160 characters. If you exceed this length the message will be sent as more than 1 SMS. You will be charged for multiple SMS messages depending on the length.

Using MyEmail

1. Tap the **Home**  >  MyEmail to configure your account:
2. Select the type of account, incoming server settings and tap **Next/Next[Check]**.

If you tap **Next[Check]**, your phone will check the incoming server settings and finish the setup automatically. If you the setup fails then check your service provider and Email provider details.
3. Enter the outgoing server settings and tap **Next/Next[Check]**.

If you tap **Next[Check]**, your phone will check the outgoing server settings and finish the setup automatically.
4. Set the Email checking frequency, select whether to use this account by default or be notified when Email arrives, and then tap **Next**.
5. Give your account a name and set a name displayed on the outgoing message, and then tap **Done**.

Composing and sending an Email

After creating an Email account you can compose and send Emails:

1. Tap **Menu** > **Compose** from the Email Screen.
2. Tap the **To** field and enter the recipient's address. Tap **Menu** > **Add Cc/Bc** to add more recipients if required.

When you enter the address, the matching addresses saved in your Contacts will be displayed. You can tap the recipient from the list.

3. Enter the subject and the content of your Email.
4. Tap **Send**.

Reply to or Forward an Email

1. Open the Email to reply to or forward from the Email Screen.
2. Tap **Reply**, **Reply all** or **Menu > Forward**.
3. Enter the contents / recipients of your Email. Tap **Send**.

Email Settings

Tap the account from the Email Screen and tap **Menu > Account settings** :

General settings

- **Account name:** Set your account name.
- **Your name:** Set the name displayed on the outgoing message.
- **Email address:** View or edit the email address.
- **Use signature:** Select to use a signature.
- **Signature:** Edit your signature.

- **Email check frequency:** Set the email checking frequency.
- **Power-saving mode:** Enable automatic email synchronization time.
- **Default account:** Send email from this account by default.

Notification settings

- **Email notifications:** Enable status bar notification for new Email
- **Select ringtone:** Select the ringtone for incoming Email notification.
- **Vibrate:** Enable vibrate with ringtones when Email arrives.

Server settings

- **Incoming settings:** Set the incoming server settings.
- **Outgoing settings:** Set the outgoing server settings.

Getting Connected

Connecting to the Internet

You can access the Internet through the mobile network or via Wi-Fi.

Your mobile network settings are pre-configured by your service provider and there is no need to change any settings.

Wi-Fi

Wi-Fi provides wireless Internet access over distances of up to 100 meters.

1. Tap **Home**  > **Menu** > **Settings** > **Wireless & networks**.
2. Select the **Wi-Fi** check box to turn Wi-Fi on.

Connect to a Wi-Fi network

1. Tap **Home**  **> Menu > Settings > Wireless & networks > Wi-Fi settings**
The available Wi-Fi network names and security settings (open or secured) are displayed.
2. Tap a network to connect.
 - An open network will automatically connect,
 - If you select a secured network you need to enter a password.

Check the Wi-Fi network status

You can check the Wi-Fi network status from the status bar and from Wi-Fi Settings.

1. Check the  icon in the status bar.
2. Tap **Home Menu > Settings > Wireless & networks > Wi-Fi settings**, then tap the current wireless network to view the network status.

Using the Browser



You can use your Browser to visit most websites. Some web pages may not be displayed properly as some web technologies such as Flash are not supported.



Tap the **Google Quick Search** box from the **Home Screen** and enter your search request. Tap **Search** to launch the browser.

Tap the **microphone icon**  to use speech recognition. Speak your search request clearly into the microphone.

Tap **Home**  >  > **Browser** to start the browser.

- Tap the address bar, enter the website to browse and tap **Go**.
- Tap **Menu** > **Bookmarks** to select an item from your Bookmarks, Most Visited or History tabs.

Browser Menu:



1. Tap **Menu > Refresh** to reload the page. (**Stop** if still downloading)
2. Tap **Menu > More > Find on page** to search the page.
3. Tap **Menu > More > Select text**. Slide your finger to select text to copy to the clipboard.
4. Tap **Menu > More > Share page** to send the page by Bluetooth, Email, Messaging etc.
5. Tap **Menu > More > Page info/Downloads** to view the page or download history.

Open a new browser window

1. Tap **Menu > New window**  to open a new browser window.
2. Tap the address bar and enter the website address to browse.

Switch between different browser windows

1. Tap **Menu > Windows** to view all the open windows.
2. Tap the page to browse. Tap  to close a window

Open links in web pages

1. Open a web page that contains a link.
2. **Tap** a link to open the page. **Hold** the link to open the menu:
 - **Open:** Open the web page.
 - **Open in new window:** Open the web page in a new window.
 - **Bookmark link:** Save the link to your **Bookmarks**.
 - **Save link:** Download the linked web page to your phone.
 - **Share link:** Send the link by Bluetooth, Email, Messaging etc.
 - **Copy link URL:** Copy the link to the clipboard.

Download applications from web pages

1. Open a web page that contains an application link.
2. Tap the link or hold on the link and select **Save link** to download the application to your phone.

Add a new bookmark

1. Open a web page.
2. Tap **Menu > Bookmarks**.
3. Tap **Add**.
4. Enter a name of the bookmark and tap **OK**.
Bookmarks are sorted by time with the latest at the top.

Edit a bookmark

1. Open a Browser window.
2. Tap **Menu > Bookmarks**.
3. Select an item to edit and hold it until the shortcut menu pops up.

4. Select **Edit bookmark**.
5. Edit the name or location, and then tap **OK** to save it.

Delete a bookmark

1. Open a Browser window.
2. Tap **Menu > Bookmarks**.
3. Select an item to delete and hold it until the menu pops up.
4. Select **Delete bookmark** and tap **OK** to confirm the deletion.

Browser Settings

Tap **Menu > More > Settings** from the browser to adjust the Browser settings:

Page content settings

- **Text size:** Adjust the browser text size.
- **Default zoom:** Set the browser default zoom.
- **Open pages in overview:** Show an overview of newly opened pages.
- **Text encoding:** Select a text encoding type.
- **Block pop-up windows:** Select to block pop-up windows.
- **Load images:** Select to show the images of web pages.
- **Auto-fit pages:** Select to format the web pages to fit the screen.
- **Landscape-only display:** Display web pages in landscape only mode.
- **Enable JavaScript:** Select to enable JavaScript.
- **Enable plug-ins:** Select to enable plug-ins.
- **Open in background:** Open new windows behind the current one.
- **Set home page:** Select to edit the home page web site.

Privacy settings

- **Clear cache:** Delete all the cached page contents.
- **Clear history:** Clear the browser navigation history.
- **Accept cookies:** Select to allow sites to save and read cookies.
- **Clear all cookie data:** Clear browser cookies.
- **Remember form data:** Remember form data for later use.
- **Clear form data:** Clear the saved form data.
- **Enable location:** Select to allow sites to request access to your location.
- **Clear location access:** Select to clear location access for all websites.

Security settings

- **Remember passwords:** Save usernames and passwords for web sites.
- **Clear passwords:** Clear saved passwords.
- **Show security warnings:** Show site security warnings.



Advanced settings

- **Reset to default:** Clear all browser data and reset all settings to default.

Bluetooth

Bluetooth enabled devices can exchange information within a distance of about 10 meters without any physical connection. The Bluetooth devices must be paired to share information.

Turning Bluetooth on or off

1. Tap **Home**  **Menu > Settings > Wireless & networks.**
2. Tap the **Bluetooth** check box to turn Bluetooth on.
The  icon will be displayed in the status bar. If you want to turn Bluetooth off, clear the **Bluetooth** check box.

Make your device visible

Other Bluetooth devices can detect your phone, establish a partnership, or use a Bluetooth service.

1. Tap **Home**  **Menu** > **Settings** > **Wireless & networks** > **Bluetooth settings**.
2. Select the **Bluetooth** check box to turn on.
3. Select the **Discoverable** check box to make your device visible.

Change your device name

1. Tap **Home**  **Menu** > **Settings** > **Wireless & networks** > **Bluetooth settings**.
2. Select the **Bluetooth** check box to turn on.
3. Tap **Device name**.
4. Enter the name and tap **OK**.

Pair with another Bluetooth device

To Pair with another Bluetooth device both devices must have Bluetooth turned on.

1. Tap **Home**  **Menu** > **Settings** > **Wireless & networks** > **Bluetooth settings**.
2. Tap **Scan for devices** to display available devices in your vicinity.
3. Tap the device to pair with and enter your PIN if required. The same PIN should be used on both devices.

Bluetooth Connect Permissions

Audio devices (HFP/A2DP/AVCRP) will always Connect when in range.
Phonebook (PBAP) can be set to Always ask or Always accept.
File transfer (OPP) is set to Always ask.

Connect to a Computer

Copy files between the phone and any computer using the USB lead supplied. Select Mount when prompted on the phone to connect your microSD™ memory card to the computer. Browse your computer to see the connected drive as an external storage device.

Use computer connectivity to transfer audios, videos, pictures and to back up your contacts and applications.

You can set Mount options from the following menu:

Menu > Settings > USB Settings > Connect to PC Settings

Use the Join Me Connection Suite to Synchronise your Phone

If there is a CD supplied with your handset, insert this into your computer to install the Join Me connection suite. Otherwise Join Me is embedded in your device. Connect the handset to your computer using the USB lead supplied and browse the CDROM folder to run the Join Me installation.

Using Multimedia Functions

Camera



Tap **Home**  > **Camera** to open the camera:

Brightness

View last shot

Press the **menu** key for Settings



Zoom

Taking Pictures

Line up your shot and tap  to take the picture.

- Tap the icon in the right corner of your screen to view the picture.
- Tap **Menu > Gallery** to view all of your pictures.

Camera Settings

Tap **Menu > Settings** to adjust camera settings:

- **White balance:** Adjust the white balance to capture colours more accurately in different conditions.
- **Anti Banding:** Automatically adjusts for specific AC frequencies to avoid interference stripes.
- **Color effect:** Tap to select picture effects.
- **Store location:** Select to record location in picture data.
- **Select ISO:** Tap to set the ISO level to 100, 200, 400, or 800, or Auto.

- **Picture Size:** Select the size of your captured pictures.
- **Picture quality:** Adjust the picture quality.
- **Focus mode:** Turn autofocus on or off.
- **Sharpness:** Adjust the sharpness to provide more clarity of detail
- **Contrast:** Adjust the contrast to see sharper colours
- **Saturation:** Adjust the saturation to change colour intensity
- **Restore to default settings:** Restore the camera settings to default.

Video Recorder



Tap **Home**  >  > **Camcorder** to open the camcorder.

Switch from the camcorder to camera mode using the selector switch on the screen 

Shooting Videos

1. Tap  to start shooting.

2. Tap  to stop shooting.



Notes:

- Tap the icon in the right corner to view the last video clip.
- Tap **Menu** > **Gallery** to view all of your video clips.

Video Settings

Tap **Menu > Settings** to adjust the Video Settings:

- **Video quality:** Select the video quality type.
- **Video Encoder:** Select the video encoder type.
- **Audio Encoder:** Select the audio encoder type.
- **Video duration:** Tap to set the video duration.
- **Restore to default settings:** Restore the camcorder settings to default.

FM Radio







Your phone includes an FM radio. The wired headset works as an antenna, so always connect the headset when using the radio. If you receive an incoming call while listening to the radio, the radio will be suspended.

Open the FM Radio

Insert the headset and Tap **Home**  >  > **FM Radio**.

The  icon is shown on the status bar.

1. Tap  or  to scan for channels automatically.
2. Tap **Menu** > **Adjust**, and then tap  /  to fine tune the frequency if required.
3. Hold on a frequency until a red box appears on the screen, and then drag it to the box to save the frequency.

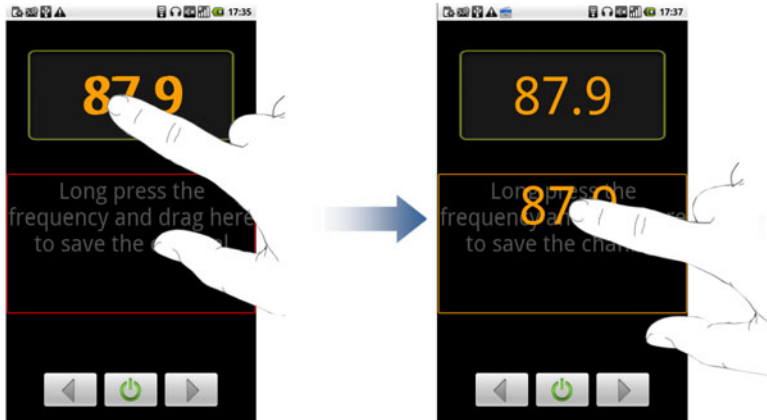



4. Press **Volume Keys** to adjust the volume.
5. Tap **Menu > Sleep** to set the FM radio sleep timer.
6. Tap  to turn off the FM radio.

Music



You need to have audio files stored on your memory card. Use downloads, Bluetooth or PC Connectivity to save files onto your memory card.

1. Tap **Home**  >  >  **Music** to open Music application.
2. Select a file to open from the Artist, Album or Song folders.

Creating Playlists

1. Select a music file to add to a new playlist.
2. Tap and hold on the file until a shortcut menu pops up.
3. Tap **Add to playlist**.
4. Tap **New**.
5. Enter the playlist name and tap **Save**.
The playlist is created and the selected file is added to the playlist.

Music Player Controls

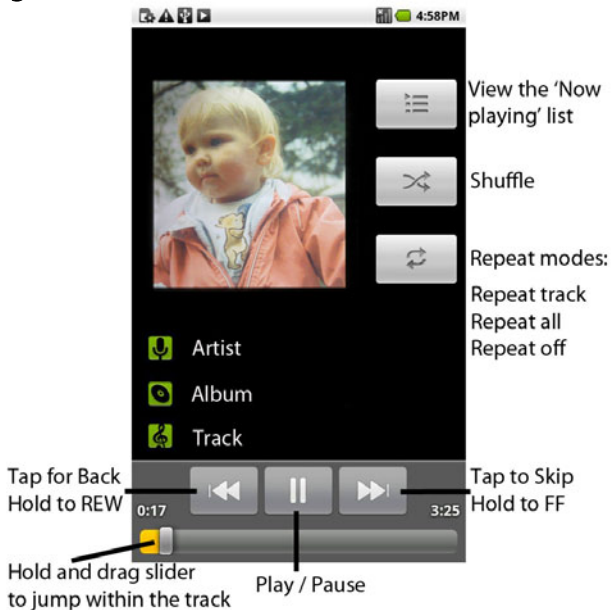

Managing Your Playlists

1. Tap **Playlist** from the Music Screen to view all playlists.
2. Hold on the playlist you want to play or edit until a shortcut menu pops up.
 - Tap **Play** to play the playlist.
 - Tap **Delete** to delete the playlist.
 - Tap **Rename** to edit the playlist name.

Setting a Song as Ringtone

1. Open the folder where the song you want to set as ringtone is.
2. Hold on the song until a shortcut menu pops up.
3. Select **Use as ringtone**.

You can also set a song as ringtone when you are playing it by tapping **Menu > Use as ringtone**.

Videos

Open Videos to view your Video files 

Tap **Home**  >  > **Videos** to open the video player.

1. Tap the video file you want to play from the Videos Screen.
2. Tap on the screen to show the control bar.

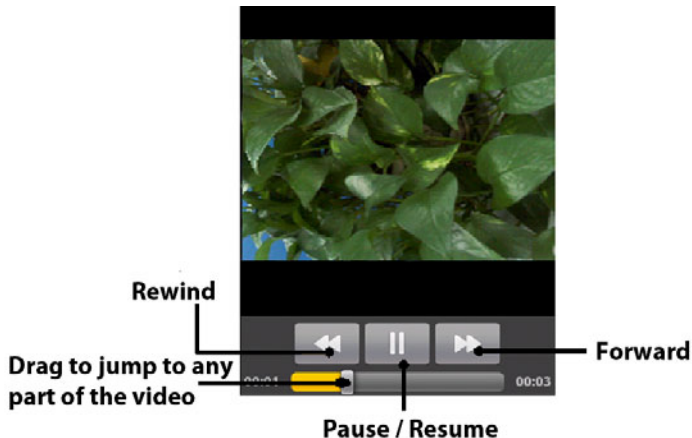

Gallery



Use **Gallery** to view pictures and play back videos. You can also set pictures as wallpaper, contact icons and share them with your friends.

Tap to return to previous folder

Tap to return to Gallery

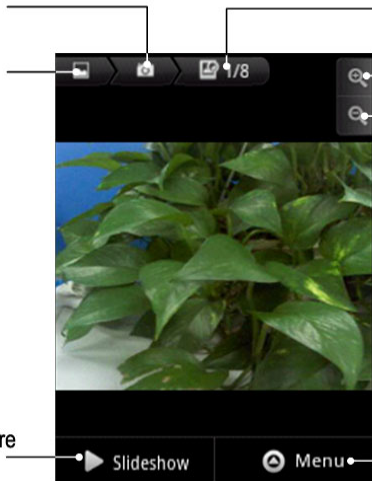

Show the number of the pictures

Tap to zoom in

Tap to zoom out

Tap to open the Gallery Menu

Tip:
Double-tap to zoom the image

Tap to view picture in slideshow





Sound Recorder



Sound Recorder enables you to record your voice memos that you can also set as a ringtone.

Tap **Home**  >  > **Sound Recorder**.

Record Your Memo

1. Hold the phone so the microphone is near your mouth.
2. Tap  to start,  to stop and  to play back.
3. Tap **OK** to save the voice recording, or tap **Discard** to discard the recording.
4. Files are stored at: **Home**  >  > **Music** > **Playlists** > **My recordings**.
5. **Hold** the recording and select **Use as phone ringtone** to set as your Ringtone.

Google Applications

Sign In or Create Your Google Account

Sign in to your Google Account to synchronize Gmail, Calendar, and Contacts between your phone and the web.

1. Tap a Google application, such as **Talk**.
2. Follow the instructions in the wizard and tap **Next**.
3. Tap **Sign in** if you have a Google account.
Enter your user name and password, and then tap **Sign in**.
Tap **Create** if you do not have a Google account.

Using Gmail



Gmail is Google's web-based email service. Gmail is configured when you sign in to your Google account. Depending on your synchronization settings, Gmail on your phone is automatically synchronized with your Gmail account on the web.



Tap  > **Gmail** to open.

Create and send an Email

1. In the Inbox, press **Menu** and then tap **Compose**.
2. Enter email address in the **To** field. If you are sending an email to several recipients, separate the email addresses with a comma. You can add as many message recipients as you want.
3. Enter the email subject, and then compose your email.
4. After composing your email, tap **Send**.

Using Google Calendar



Tap **Home**  >  > **Calendar** to use Google Calendar. You can use the calendar to schedule appointments, meetings and other events. Your appointments are displayed on the screen as they are scheduled. All appointments are synchronised to your Google account, which enables you to share your schedule, get your entire calendar on the go, and receive Email reminders for your upcoming events.

Using Google Talk



Google Talk is Google's instant messaging program, which enables you to communicate with other people that also use Google Talk.

Open Google Talk

Tap Home  >  > Talk.

Add a new friend

You can only add people who have a Google Account.

1. In the Friends list, press **Menu > Add friend**.
2. Enter the Google Talk instant messaging ID or Google email address of the friend you want to add.

View and accept an invitation

1. In the Friends list, press **Menu > Invites**.
All chat invitations you have sent or received are listed on the pending invitations screen.
2. Tap a pending invitation, and then tap **Accept** or **Decline**.

Change your online status

1. Tap the online status icon to update your status.
2. Tap the status message box and enter your status message using the onscreen keyboard.

Start a chat

1. Tap a friend from your Friends list and enter text on the on-screen keyboard.
2. After entering your message, tap **Send**.

Settings



Wireless & Networks Settings

Enable data roaming

1. Tap  > Menu > Settings > Wireless & networks > Mobile networks.
2. Select the **Data roaming** check box to enable data roaming.

Switch network mode

1. Tap  > Menu > Settings > Wireless & networks > Mobile networks > Network Mode.
2. Set the preferred mode: **GSM/WCDMA auto**, **WCDMA only**, or **GSM only**.

Switch network operators

1. Tap  > **Menu** > **Settings** > **Wireless & networks** > **Mobile Networks** > **Network operators**.
2. Tap **Search networks** to set the network operator manually, or tap **Select automatically** to set the network operator automatically.

Set Access Point Names

You can use the default Access Point Names (APN) to connect to the internet. If you want to add a new APN, please contact your network operator to get detailed information.

1. Tap  > **Menu** > **Settings** > **Wireless & networks** > **Mobile networks** > **Access Point Names**.
2. Tap **Menu** > **New APN**.
3. Set the necessary parameters. Tap **Menu** > **Save**.

Sound Settings

Tap  > **Menu** > **Settings** > **Sound & display** to configure the sound settings, such as ringtones and notifications.

Silent mode

Select the **Silent mode** check box from the Sound & display settings.

The silent icon  is displayed on the status bar.

Ringer volume

Set the ringer volume, make sure your phone is not in silent mode.

1. Select **Ringer volume** from the Sound & display settings.
2. Adjust the ringer volume and tap **OK** to save.

Adjust the ringer volume by pressing the Volume Keys from any screen.

If you want to adjust the notification volume together with ringer volume, select the Use incoming call volume for notifications check box.

Media volume

Set the media volume for **Music** and **Videos** players.

1. Select **Media volume** from the Sound & display settings.
2. Adjust the media volume and tap **OK** to save.

Phone ringtone

1. Tap **Phone ringtone** from Sound & display settings.
 2. Tap the available ringtones to select from the pop-up list.
- You can also set an audio file as the ringtone from the music list.

1. Tap **Home > Menu > Music > Songs**
2. Select and hold the song until the menu pops up.
3. Select **Use as phone ringtone**.

Phone vibrate

Tap **Menu > Settings > Sound & display > Phone vibrate** to enable vibrate mode (in addition to normal ringing).

Silent mode selected from the Power Key menu is vibrate only and the vibrate icon  is shown on the notifications bar.

Notification ringtone (for messages and other notifications)

1. Select **Notification ringtone** from the Sound & display settings to set the Notifications tone.
2. Scroll the ringtone list and select one to set as the default notification ringtone. Tap **OK** to save.

Audible touch tones

Enable tones when using the Dialer.

Audible selection

Enable sounds while making a selection by touching the screen.

Enable Haptic feedback

Haptic feedback provides a vibrate response when pressing the keys.

SD card notifications

Enable a notification sound for microSD™ card USB Mounting. Mounting enables the card to be read on a computer when connected via USB.

Display Settings

Tap  > **Menu** > **Settings** > **Sound & display** to configure the display settings, such as orientation, animation, brightness etc.

Orientation

Select to automatically switch between landscape & portrait.

Animation

Select animation modes when opening or closing windows.

Brightness

Set your required Brightness.

Screen timeout

Set the screen timeout delay from the available options.

Calibration

Run the screen calibration routine. Follow the steps to calibrate the touch display if required.

Location & Security Settings

My Location

Use **Wireless networks**, **GPS** and **Assisted GPS** to integrate with Location based services such as Google Maps.

Screen Unlock Pattern

You can protect your phone from unauthorized use by creating a personal screen unlock pattern.

1. Tap  > **Menu** > **Settings** > **Location & security** > **Set unlock pattern**.
2. Read the instructions and tap **Next**.
3. Watch the example pattern and tap **Next**.
4. Draw your own pattern and tap **Continue**.
5. Draw the pattern again and tap **Confirm**.

If you forget your unlock pattern then contact your service provider to repair your device. This may be chargeable.

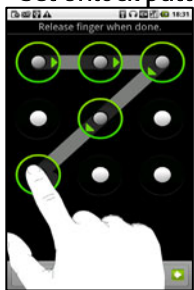

Lock the screen

Press the **Power Key** to lock the screen.

Unlock the screen with a pattern

1. Press **Power Key**.
2. Draw your pattern to unlock the screen.

If you make a mistake you can try again.

If you forget the unlock pattern then contact your Service Provider.

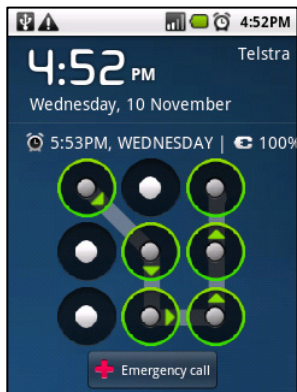

(U)SIM Card Lock

Set a PIN code on your SIM card to prevent others from using your account. The initial PIN code is provided by your service operator.

1. Tap **Home**  > **Menu** > **Settings** > **Location & security** > **(U)SIM card lock**.
2. Select **Setup (U)SIM card lock**. Enter the PIN and tap **OK**.

Change SIM PIN

Before changing SIM PIN, you need to enable it.

1. Tap **Home**  > **Menu** > **Settings** > **Location & security** > **(U)SIM card lock**.
2. Tap **Change (U)SIM PIN**.
3. Enter the PIN and tap **OK**.
4. Enter a new PIN and tap **OK**. Confirm the new PIN and tap **OK**.

Passwords

Set to show or hide Visible Passwords as you type.

Credential Storage

You can select to allow applications to access secure certificates and other credentials.

Enable secure credentials

1. Tap Home  > Menu > Settings > Location & security .
2. Tap **Set password** to create a password.

You can also install encrypted certificates from the microSD™ card by tapping **Install from SD card**.

3. Select **Use secure credentials** check box.

Delete credentials

1. Tap **Settings > Location & security**.
2. Tap **Clear storage** to clear credentials.

Application Settings

Unknown Sources

Allow the installation of non-Market applications.

Manage Applications

View and manage applications installed in your phone.

Running Services

View and control currently running services.

Development

View and set development options.

USB Settings

Connect to PC Settings

Configure the SD Mounting options when connected to a computer.

Mounting the SD card makes it visible on the PC in order to copy files to and from the PC. If the card is mounted to the PC then it can't be used by

the phone, ie music files from the card will not be accessible on the phone while connected and mounted on the PC.

Charging Settings

Normally the phone will charge via the USB cable. You can disable this setting (eg. to save laptop power) if required.

Accounts and Sync Settings

Manage accounts and set whether applications can sync data automatically.

Privacy Settings & Factory Reset

Use my location is required for Google Maps but can be disabled for privacy purposes.

Back up my settings saves your settings on line with Google.

Factory data reset will perform a factory default. **Note** that a factory reset will erase all your data except that stored on the microSD™ card. You can use third party applications such as Astro to back up your apps if required.

SD Card, USB Mass Storage & Phone Settings

- View the **SD card** available space.
- Unmount the SD card, and format the card if required.
- View the phone internal storage space.

Search Settings

Manage search settings and clear search history.

Language & Keyboard Settings

You can change the system language of your phone and configure your accessibility preferences.

Text to Speech

This feature requires you to download an application from the Android Market. Follow the prompts to complete the installation.

Date & Time Settings

1. Tap **Home**  > **Menu** > **Settings** > **Date & time**.
2. Clear the **Automatic** check box to set time and date manually.
3. Configure the time and date settings:
 - Tap **Set date**. Adjust the date, and tap **Set** to save it.
 - Tap **Select time zone** and tap the area where you are.
 - Tap **Set time**. Adjust the time, and tap **Set** to save it.
 - Tap the check box behind **Use 24-hour format** to change the time format.
 - Tap **Select date format** and select the type you like.

Technical Specifications:

Size and Weight	102.8 × 54.8 × 14.8mm. 103g with battery	
Networks	2G GSM 850, 900, 1800, 1900 MHz 3G UMTS 850, 2100 MHz. HSDPA 7.2 Data	
Display	TFT QVGA, 320 x 240, 2.8", 262K Colours	
Back camera	3.2M Pixels, Auto-focus with 5 x digital zoom.	
Removable memory card	2GB microSD™ included, supports up to 32GB	
Battery	Capacity	1100mAh Li-ion
	Charge Time	3-4 hrs with AC Charger
	Standby time	Up to 200 hours (+/- 20% subject to network)
	Voice talk time	Up to 150 mins (+/- 20% subject to network)
WAP browser version	WAP2.0	
Connectivity	Bluetooth 2.1 with EDR. Wi-fi 802.11b/g	
Supported file types	jpg, gif, png, amr, mid, mp3, mp4, 3gpp, h263.	

Troubleshooting and Warranty Information

Please check the manual thoroughly before contacting your service provider.

Symptom	Solution
No incoming ring or alarm tone	Hold the power key to check the phone is not in silent mode. Check the ring tone and ring volume settings.
How do I extend the incoming ring time?	This is not a device setting. Please contact your Service Provider to extend the ringing time.
How do I change the Ringtone?	Go to Settings > Sound & display > Phone ringtone
A phone number cannot be dialled	Check for network coverage Check you have Voice enabled on your plan. Check you have an active account or credit.
I cannot connect to the internet	Check for network coverage. Check you have a valid data SIM with available credit.

Symptom	Resolution
My phone is slow to respond or freezes	Restart your phone to refresh the memory. Uninstall applications you are no longer using.
The battery discharges quickly	Check the network signal strength. With only 1 or 2 bars, the battery has to work harder to maintain network contact. Switch off Wi-Fi, Bluetooth & GPS if you are not using them. Tip: You can add the power management widget to your home screen to easily switch off functions. The battery may be worn out.
I cannot charge the phone	Confirm the charger is properly inserted. Remove the battery, clean the contacts and check it is inserted correctly. The battery may be worn out. Tip: Charge the phone by connecting to a computer using the USB lead supplied.

Symptom	Resolution
I cannot connect to other Bluetooth devices	Turn Bluetooth on. Set visibility to Show. Make sure the pass-code is correct. Possible compatibility issues. Not all functionality is supported.
I cannot unlock my screen	If you have forgotten your unlock pattern you need to contact your Service Provider.
How do I reset the phone?	Go to Settings > Privacy > Factory data reset

Error Messages

Message	Solution
No SIM Card	Check a valid SIM card is inserted. See the <i>Introduction</i> section
Enter PIN code	You have set a SIM PIN. Please enter your SIM PIN code.
Enter PUK code	Contact your Service Provider to get the PUK code
Enter Unlock Code	Contact your Service Provider to obtain the network unlocking code.

Warranty Information

The warranty does not apply to defects or errors caused by:

- (a) Normal wear and tear
- (b) Misuse including mishandling, physical damage, improper installation – including battery, and unauthorised disassembly of the product.
- (c) Water, exposure to solvents or any other liquid damage.
- (d) Any unauthorised repair or modification.
- (e) Power surges, lightning, fire, flood or other natural events.
- (f) Use of the product with unauthorised third party products such as generic chargers.
- (g) Any other cause beyond the range of normal usage for products.

The End User shall have no right to reject, return, or receive a refund for any product under the above-mentioned situations. The End User's statutory rights are not excluded by these terms and conditions.

Note: Consult the warranty card for full information.