

User Manual

braxx[®] wire

Electric Wire Saw wb12s



EDT EURODIMA GMBH
Diamond Technologies
Lagerstrasse 6
A-5071 Wals bei Salzburg
Tel.: +43 (0) 662 / 42 42 48
Fax: +43 (0) 662 / 42 42 48-20
e-Mail: office@eurodima.com
www.eurodima.com

Branch in Germany:
Oberheinrieter Straße 30 - 32
D-74199 Unterheinriet
Tel.: +49 (0) 7130 / 40095 0
Fax: +49 (0) 7130 / 40095 20
e-Mail: office@eurodima.com
www.eurodima.com

Table of Contents

1	Introduction	3
2	EU Declaration of Compliance	4
3	Intended Use.....	5
4	Specifications.....	5
5	General notes electric pneumatic saw wb12s.....	6
6	Safety	7
6.1	Dangerousness of the wire saw wb12s	7
6.2	Intended use	7
6.3	Danger	8
6.4	Emissions.....	8
6.5	Sources of danger.....	8
6.6	Workplace	9
6.7	Approved Operators.....	9
6.8	Personal safety measures	9
6.9	Safety measures at the installation place	9
6.10	Emergency measures	10
7	Safety Equipment.....	10
8	Mounting the System	10
8.1	Positioning	10
8.2	Electrical connection	10
8.3	Compressed air supply – pneumatic unit.....	11
9	Initial operation	11
9.1	User Manual.....	11
9.2	Turn on/off the machine	11
10	Operation	12
11	Mounting the cutting tools	12
12	Functional description.....	12
13	Maintenance and service of wire saw wb12s	14
14	Maintenance and service of the control panel	14
14.1	Air filter.....	14
14.2	Condensation water	14
14.3	Cleaning.....	14
14.4	Control of operations lighting.....	15
14.5	Compressor.....	15
15	Liability and Warranty.....	15
16	Drawings and Pictures.....	16

1 INTRODUCTION

This user manual is intended for the operators and maintenance personnel of this machine. The manual is not intended to replace correct training in operating the machine. We recommend training by qualified employees of EDT EURODIMA GMBH or by one of our authorized dealers. A protocol of receipt and training is then set up.



All persons employed in the operation, maintenance and/or repair of this machine must read and understand these instructions completely.

Please direct inquiries to the manufacturer or an authorized dealer.



Please observe our safety features and safety precautions which are highlighted by a  at the respective locations in the manual.

The wire braxx sawing system is equipped with safety features; however, various dangers can result from errors and misuse. Anyone involved in the setup, start-up, operation or maintenance of the machine must read and observe the safety precautions.



Non-observance of these safety precautions may result in

- **the injury or death of the operator or third persons**
- **damage to the machine and other assets**
- **damage to the building**
- **inefficient operation of the wall saw.**

For simplicity reasons, the abbreviation „wb12“ is used in this document.

2 EU DECLARATION OF COMPLIANCE

Manufacturer : EDT EURODIMA GMBH
Lagerstraße 6
A-5071 Wals bei Salzburg



Description: wire saw system, consisting of remote control panel,
wire saw storage unit and wire guiding device

Type: **Wire saw system wb12s**
Control panel wb12sms

Serial number: _____

We herewith confirm that the design and construction of the aforementioned machine complies with the following EU guidelines and its basic safety and health regulations:

Machine Guideline 89/392/CEE, i.d.F. 91/368/CEE
Guideline - Electromagnetic Compatibility (EMC) 89/336/EG, i.d.F. 93/31/CEE
Low Voltage Guideline 73/23/CEE

The following harmonized standards were applied

EN 292-1
EN 292-2
EN 294
EN 60204

The following documentation is completely included in the user manual

- Description of precautions to prevent machine-related dangers
- Operator instructions for the machine
- Spare parts list

This declaration is no longer valid if the machine is modified in any way without prior consultation with us and without our prior approval.

Wals, 01.04.2009



Dipl.-Ing. Wolfgang Stangassinger
Managing Director

3 INTENDED USE



Important safety note

The eurodima machines may not be used in conjunction with other brands of machines unless recommended or approved by EDT EURODIMA GMBH. Non-observance will void the warranty and any product liability.

4 SPECIFICATIONS

Rated voltage	230/400 V
Current consumption	27,8 A, 3PH/N/PE
Power	13 kW, water cooled
Frequency	87 Hz
Revolutions	0 – 2200 min ⁻¹
Protection class	JP 55 (IP 56)
Cutting speed	2 - 30 m/sec, frequency controlled up to 87 Hz
Pressure	8 bar
Dimensions	1875 x 620 x 820 mm
Weight	192 kg without control unit
Maximum wire storage	4 + 12 m

5 GENERAL NOTES ELECTRIC PNEUMATIC SAW WB12S

The wire saw system consists of a wire guiding device that is mounted at the cut. The wire saw unit wb12 is then positioned and/or mounted considering the specific application.

The saw system is made up of the following components:

- stable machine frame; at the same time compressed-air store
(Pict. 1 pos. 1) see p. 16
- electric drive motor; dismantlable by quick separation system
(Pict. 1 pos. 2) see p. 16
- dismantlable saw head with special drive gear, offset rolley, two counterrotating guide rollers and two swivel rollers
(Pict. 1 pos. 3) see p. 16
- feed unit with two partly counterrotating guide rollers, guided by two air cylinders without piston rods
- dismantlable protection device
(Pict. 2 pos. 1) see p. 16
- dismantlable transport wheels
(Pict. 1 transport wheels) see p. 16
- two handles
(Pict. 1 handles) see p. 16
- mobile control unit with integrated air compressor
- electric cable set from control unit to drive motor of the wire saw
- air hose 3-parts from control unit to wire saw

6 SAFETY



Warning

Check the compatibility of the voltage and the frequency with the data on the rating plate prior to use. Repairs must be carried out only by qualified personnel.

6.1 Dangerousness of the wire saw wb12s

The wire saw system wb12 is equipped with protection devices, however, there is danger when operating it faultily or misuse it. All persons that are concerned with the set-up, the initial operation, the handling and maintenance of the system, have to carefully read and adhere to the following notes.

6.2 Intended use

The wire saw wb12 is built state-of-the-art. If the machine is used in an other than the intended way, it is dangerous for the user.

- The system is suitable only for wire saw works, using wire saws up to Ø 12 mm.
- Without the drive unit protective cover (Pict. 2 pos. 1) see p. 16, no cut may be done.
- If the air is affected by the cutting process, provide fresh air for the user for his protection (mainly when dry cutting).
- Spare wire length can be covered by safety guards. However, staying in the direction of the alignment or in the danger area (Pict. 3, see page 16) during operation is strictly forbidden.
- All used wires must be approved for a cutting speed of 30 m/sec.
- Wires may only be used if the following data is known:
 - Applicability of use (concrete, masonry, steel, cast iron etc.)
 - Dimensions
 - Allowed cutting speed
 - Allowed wire connector (preferentially bwc9 quick wire connector of EDT)
- Chapped or deformed wires may not be used.
- Prior to every use, the diamond wire and the wire connector must be checked for damages. When defect, the wire resp. the wire connector must be renewed.
- Dry and wet cut: The wire saw system wb12 is designed for both dry and wet cuts.
- **Caution high-voltage current!**
Danger to life, when lines are cut or defect!

All system use beyond is classified as not complying with the regulations. For damages resulting from this misuse, the manufacturer cannot be held liable. The risk is borne by the user himself.

6.3 Danger

Through wire sawing, particles are torn out of the material and the grinding medium with high speed. Due to the different workpiece forms, it is not possible to fit the safety guard exactly to the workpiece. Provide appropriate workwear (see personal protection measures). Always consider the safety clearance – the danger area is the idle wire length (Pict. 3, see page 16).

Fire hazard:

- Never cut near flammable substances or in rooms with explosives!
- Never cut workpieces from aluminium, magnesium, or any aluminium or magnesium alloys!
- Aluminium and magnesium chipping is readily flammable!
- Do not cut any material where harmful dust or vapours are produced in the grinding process (e.g. asbestos at renovations etc.)!
- Do not cut any material where explosive dust is produced in the grinding process!

If above-mentioned work is done, clarify separately which further safety measures are to be conducted. Your contact is your regulatory authority and your professional association.

6.4 Emissions

The A-rated equivalent continuous sound pressure level of this system is lower than 75 dbA, thus no ear protection is needed. Hence, this wire saw is especially suitable for the use in construction of public social institutions such as hospitals and nursing homes.

6.5 Sources of danger

- High wire speed
- Danger at a potential wire crack, by whipping of the wire and consequently flying wire or closure parts, being able to cause heavy chip or crush injuries.
- If any limbs come between the wire and the roller guides, they can be pinched or cut off. Loose clothes can be trapped inbetween the operating wheels, too. Thus, absolutely avoid the danger area (Pict. 3, see page 16) during machine operation.
- Prior to maintenance and cleaning, the motor must be switched off and the voltage supply must be disconnected (pull out power plug)
- Turn off the motor before you leave the machine.
- Leave the machine only when it is brought to a halt.
- Never remove safety equipment, or never change the system so that the safety devices do not function anymore.
- During the cutting operation, never stay in the alignment of the idle wire (Pict. 3, see page 16).

Danger through high voltage current – danger to life!

6.6 Workplace

The user's workplace is at the control panel, which is to be placed laterally to the wire saw unit and out of the danger area (Pict. 3, see page 16).



Caution – never stay in the alignment of the wire level!

6.7 Approved Operators

The system may only be used, maintained and repaired by personnel who know the system and are aware of the potential dangers. This user manual has to be absolutely adhered to and should always be available (with a duplicate in the control unit). The operating company has to provide the manual to the user and make sure that he has read and understood it. Only then, the user may operate the system.

Youths under the age of 16 must not operate the wire saw system!

The responsibilities for the different tasks at the unit must be clear and complied with. No unclarities may occur as they endanger the user's safety.

The user has to ensure that only authorized personnel operate the machine. He is responsible towards third parties in the working area of the unit.

6.8 Personal safety measures

- Use safety goggles for protection against metal, concrete and masonry chips in the air.
- Wear protection gloves against sharp-edged wires and on cut pieces.
- Wear tight clothes, no jewellery and put your hair back or cover it.
- According to the type of cutting, further protection is recommended:
 - dust mask
 - ear protection
 - leather apron
 - face protection
 - safety shoes



Use hard hat



Use breathing protection



Use safety goggles



Use ear protection



Use safety shoes



Use protective clothing



Use protection gloves

6.9 Safety measures at the installation place

The unit must stand securely on a firm level surface. For cuts with more than 4 m wire-concrete contact surface or at flat surface, the machine can be fixed with a tube bar.

Secure by according internal instructions and checks that the workplace and its surroundings always are clean and clear.

6.10 Emergency measures

In case of emergency, immediately turn off the system via emergency-stop button at the control panel.

7 SAFETY EQUIPMENT

- Prior to every shift (after interruption in use), after every maintenance or repair work, check the safety equipment. Check the specified conditions and position, the secure fixation, and the required functions.
- If there are any defects during operation, immediately stop the unit and eliminate it.
- Do not change or remove any safety equipment.
- Do not make changes at the machine that disable any safety equipment.

8 MOUNTING THE SYSTEM

8.1 Positioning

Mount the wb12 well with the adjustable feet and position the control unit with a sidewise long enough distance (Pict. 3, see page 16).

The unit has to be set up on a firm level surface securely and when the underground is flat and slippery, it has to be fixed with anchor screws, tension belts or bracing rods against any displacement. The equipment for wire guiding (guiding system 3-wheel or compatible, existing roller systems) has to be fixed securely onto the workpiece with an anchor screw. For safety reasons and for cutting as precisely as possible, mount them as close to the cut as possible.

8.2 Electrical connection

- According to the connection data at the specification plate of the unit, the electrical connection is to be conducted with the EN 60204 guidelines.
- Check whether the supply voltage complies with the operating voltage given on the unit.
- The connection must be done by a plug connexion with rotary current.
- The specific regulations of the local electric power station have to be adhered to. With a 4-wire network, the standard control panel cannot be used. Therefore, the special 4-wire network has to be utilised. Caution: It is not applicable together with IT networks (inhouse networks).
- Shortly turn on / off the unit at the on / off switch (see p.16, Pict. 13, pos. 1 and 4). Check the rotational direction of the drive wheel.
- At the initial operation, the machine should idle and with motor cooling for 10 min.

8.3 Compressed air supply – pneumatic unit

The compressed air supply with 3-parts hose package between the wb12 wire storage and control panel is to be connected, via two control wires and an air-supply line to the frame of the saw unit, of air reservoir design.

The pneumatic unit, having only one pneumatic cylinder, is equipped with an optimised belt guide system. The cylinder is designed with piston rods; there is no moving out over the total machine dimensions.

The precise feed control ensures constant wear and better tool yield when used correctly. The new unit reacts much faster so that the wire always is tensioned suitably. In case of wire clamps, the improved springing effect protects tools and machine.

Due to the modular design, the pneumatic unit can be taken off the sawing system in order to facilitate transport.

The pneumatic unit is low-maintenance as the settings are adjusted automatically – neither pre- nor readjustments are necessary. It is soil-resisting due to the extra wiper rings at the guiding shaft. The pneumatic unit is splash-proof (no high-pressure cleaner!)

Maintenance works:

- Greasing the three ball guides weekly
- Check the v-belt tension after 300 operating hours

9 INITIAL OPERATION



Caution: Make sure to secure the construction site! External persons must not have any access – risk of accident!

9.1 User Manual

Prior to the initial operation, the user manual and the safety instructions must be read carefully and adhered to. The safety equipment must be checked.

9.2 Turn on/off the machine

- Turn on the system:
Tighten the wire with feed pneumatic valve, set the pressure according to the roller layout at the pressure regulator and secure feed slide by mounting the stopper (see p.16, Pict. 13, pos. 1).
- Activate the machine: press button EIN (green)
- Raise the cutting speed via the potentiometer (max. 30 m/sec)
Turn off machine: press button AUS (see p.16, Pict. 13, pos. 4).

10 OPERATION

- Have you read and understood the safety instructions? You must not operate the system before.
- Mount the safety equipment correctly.
- Consider the personal safety measures.

11 MOUNTING THE CUTTING TOOLS

- The wires may only be mounted and installed by trained personnel.
- Only wires with a diameter of max. 12 mm, that fit onto the rollers, may be used.
- When mounting the wire connections, the indications of the tool manufacturer have to be considered. The turning of the diamond wire has to be done accordingly.
- When using wire fastening sleeves, a new sleeve has to be installed after every cut.
- Connecting wire parts with different diameters and the use of wires with loose wire pearls or with broken carrier wire are prohibited!
- Prior to every mounting, a visual examination of the wires must be done to find any faulty points.
- The connectors have to be checked for operational reliability.
- Special attention has to be laid on the wire seating solidly on the rollers, and the swivel roller being attuned to the alignment and then fixed. Only this ensures that the wire can not skip off the rollers when the unit starts.

With these measures, an optimal function of the wire saw system wb12 can be ensured. Non-observance risks damages at the wire saw system or the wire.

When a **new** wire saw unit is put into operation, a **10 min test run at full load** should be done, due to the possibility of transport damages. Only after this test, the unit may be put into operation.

12 FUNCTIONAL DESCRIPTION

With the wb12, separating cuts in concrete, reinforced concrete, masonry, natural stone, big metal parts etc. can be conducted. All cuts, whether horizontal, vertical, floor, ceiling, mitre, diagonal or flush cuts can be done with lowest mounting and operating efforts, with the aid of suitable wire guiding systems.

The electro pneumatic drive allows the low system weight, low power supply values, highest electric efficiency, low-noise and smooth running as well as low tool wear. Furthermore, the wire saw system features highest safety in operation for the personnel due to its compactness and the protective cover of the whole wire running level within the unit.

In order to further reduce the risk of accidents, the wire is guided through hollow axles, thus, wire whipping in case of wire crack is not possible anymore.

Procedure: conducting a wire saw cut

Step 1

Drill the holes for guiding through the wire.

When parts are cut out, the holes should be made bevelled to the cutting direction, as this facilitates the construction significantly.

Step 2

Drill the holes for fixing the wire guiding device and, possibly, for fixing the unit when the surface is slippery (see 6.9, p.9).

Step 3

Mind the stable mounting of the unit. Position the control panel sideways to the unit, in a sufficient distance.

Caution: Never stay in the alignment of the idle wire length.

Step 4

Mind the stable mounting of the wire guiding device at the cut.

Step 5

Guide the wire through all hollow axles (mind the running direction) and through the holes for the cut. Twist the wire according to the manufacturers specifications, close the connector and use the required rollers. Slightly tighten the wire with the feed lever and the pressure regulator at the control panel (1 bar).

Step 6

Align the swivel rollers at the cut and the swivel rollers at the machine (= universal guiding system) exactly.

Step 7

If the material which is to be cut, has sharp edges, they have to be smoothed off and/or the wire must be countersunk via the drive wheels manually in mounted and tightened state. Then, close the guard at the unit.

Step 8

Connect the water supply at the entry spot and at about mid-contact-length of the wire. An efficient coolant supply heavily affects the cutting as a lack of cooling water leads to the destruction of the tool.

Step 9

For dry cuts, mount an exhaust device for the cutting dust. The wire cooling is done by long idle wire lengths out of the cut contact.

Step 10

If possible, idle wire lengths should be covered by safety guards or equivalent materials.

Step 11

When starting up, the pneumatic feed at the control panel must be activated (see p.16, Pict. 13, pos. A). Use less feed pressure to avoid clamping of the wire. Set the start frequency with the potentiometer and press the "Motor ein" / "motor on" key to start the saw. Start with low revolution and mind the full occupation of the rollers upon wire initiation.

Step 12

For wet cuts, run the drive motors revolution up to a wire speed between approx. 20 and 30 m/sec.

Step 13

For dry cuts, choose great wire length and low wire speed.

Step 14

Choose the feed pressure so that there is no overload of the drive motor. The amperemeter

should have a value between 25 and 30 ampere.

Step 15

Examine the wire only when the unit is standing still or the wire speed is very low (2-3 m/sec).

Step 16

When the wire reaches the center of the hollow axe, reposition the swivel rollers of the guiding device inwards in cutting direction. Thus, the wire is captured at the cut end, and a damage of the hollow axes is avoided (see Pict. 14, page 24).

Step 17

When the cut is finished, stop the machine with the emergency-stop button (see p.16, Pict. 13, pos. 4). Release feed tension only after the wire comes to a standstill.

13 MAINTENANCE AND SERVICE OF WIRE SAW WB12S

Any maintenance and service works may only be done when the unit stands still. Disconnect the power supply to the system (put on/off button in 0 position and unplug the mains plug).

The best maintenance activities are the daily removal of mud, dust and dirt.

Discharging condensation water at the wire saw system: with the provided key, open the drain screw under pressure at the back frame end. Leave open until dry air passes off the tank. Then lock the valve again.

Always use a hollow axe protection and replace if necessary.

14 MAINTENANCE AND SERVICE OF THE CONTROL PANEL

14.1 Air filter

The air filter mats, that are sideways on the control panel, must be blown out and renewed periodically. Therewith, sufficient cooling of the frequency converter is ensured. Also clean the air filter at the compressor.

14.2 Condensation water

In the sight glass of the air regulation valve, condensation water accumulates continuously. It can be discharged by simple (up-)pressing the hose nipple at the bottom side of the sight glass. The PVC hose must be connected and the water must be able to drain off to the outside (see p.16, Pict. 13, pos. F and G).

14.3 Cleaning

Outside:

Keep the control panel clean and wipe it only with a dry or moist cloth. Never use a water-jet or high pressure cleaner.

Inside:

Separate the control panel from the power supply and blow it out with compressed air. Do not use water as there is risk of short circuit.

14.4 Control of operations lighting

When activating the main switch, all lamps flash up shortly. If necessary, replace any defective illuminants.

14.5 Compressor

At a power breakdown, you possibly have to discharge the air at the compressor pressure switch, as the switch does not allow to release because of the previously built-up pressure.

Open the breather screw manually, release pressure and then turn the screw tight again (see p.16, Pict. 13, pos. H).

15 LIABILITY AND WARRANTY

Unauthorized modifications and changes to the machine as well as non-observance of the operating instructions void the manufacturer's liability for resulting damage.

We only warrant error-free operation for original replacement parts manufactured by EDT EURODIMA GMBH. Any guarantees and warranty become void if machines or machine parts have been opened. This warranty is valid on condition that the machine is used, handled, maintained and cleaned according to the operating instructions.

Claims under the warranty will be recognized up to 12 months from the date of purchase (invoice date).

The warranty includes the repair or replacement of defective parts free of charge. Parts subject to normal wear are excluded from this warranty.

EDT EURODIMA is not liable for direct, indirect or consequential damage from defects, loss or expenses in connection with or resulting from the unsuitability of the device for a specific purpose. Implied assurances of use or suitability for a specific purpose are expressly excluded.

16 DRAWINGS AND PICTURES

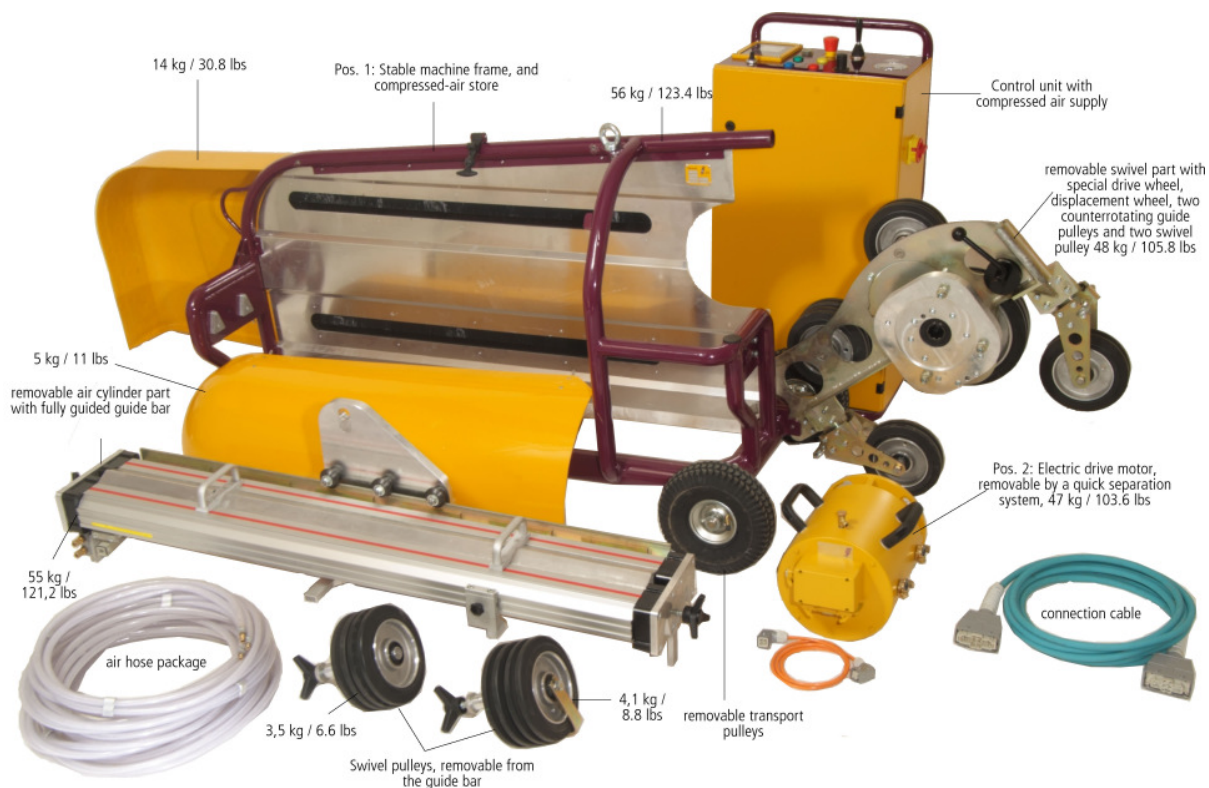

Pict. 1: System, demounted



Pict. 2: System with protection cover

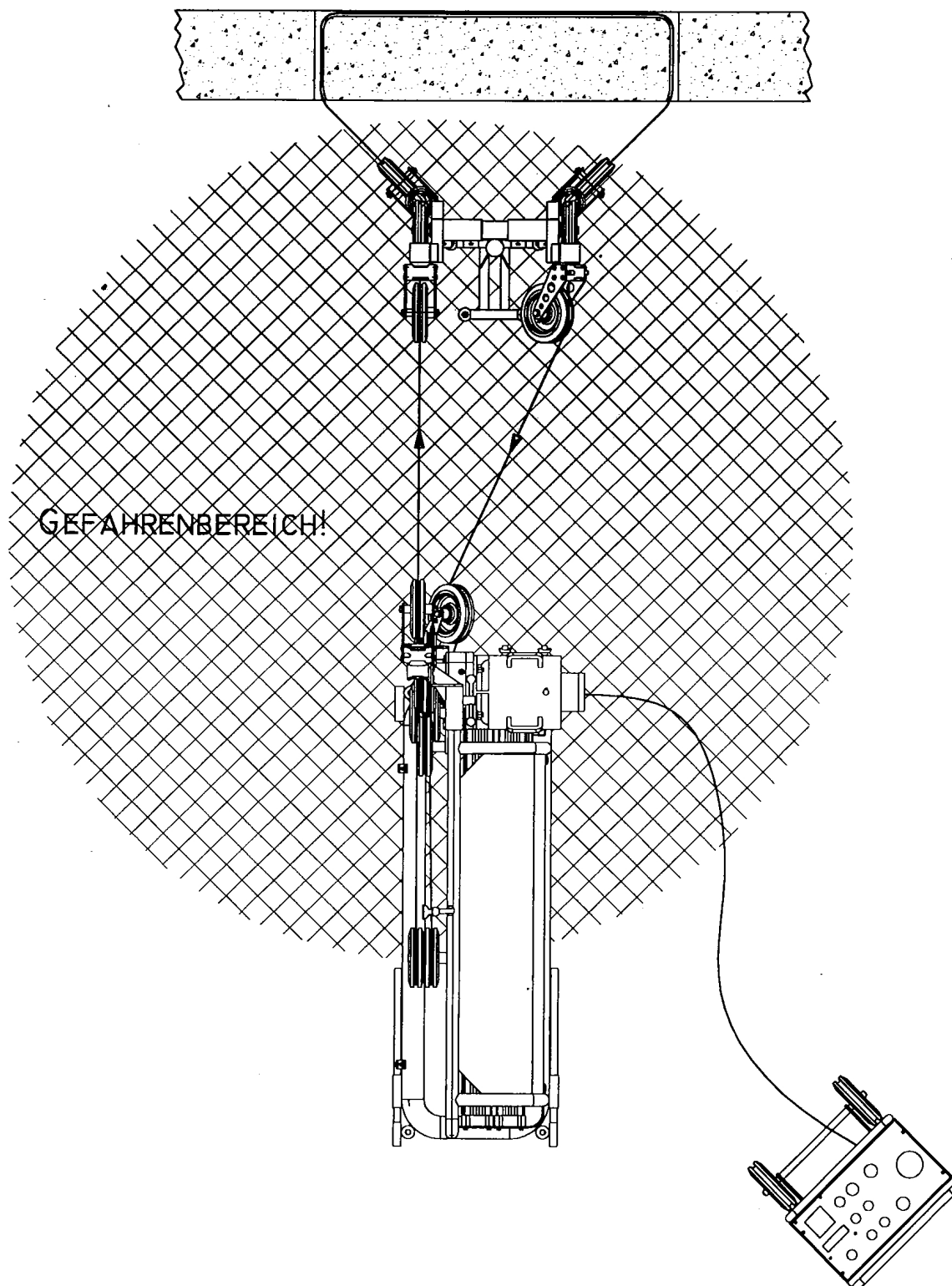

Pict. 3: danger zone

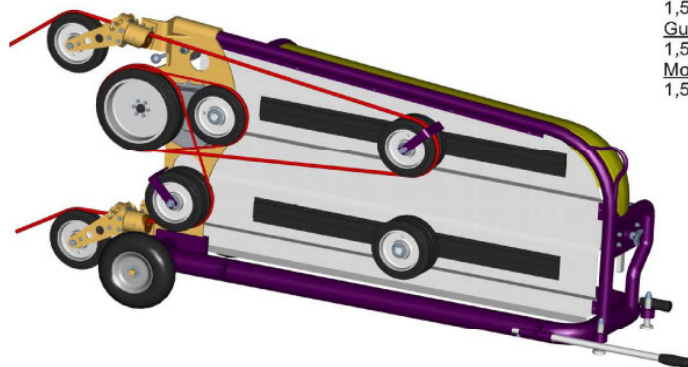

einfache Belegung:
1,5 bar
Guiding of wire 1:
1,5 bar
Mouflage 1:
1,5 bar

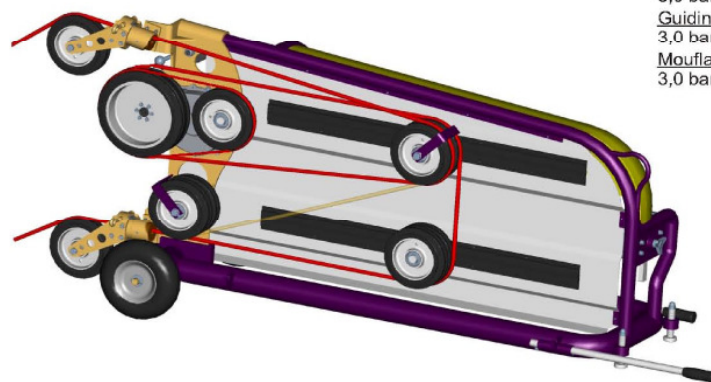

zweifache Belegung:
3,0 bar
Guiding of wire 2:
3,0 bar
Mouflage 2:
3,0 bar

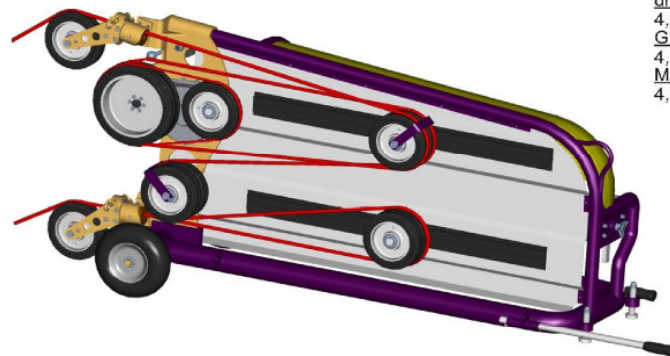

dreifache Belegung:
4,5 bar
Guiding of wire 3:
4,5 bar
Mouflage 3:
4,5 bar

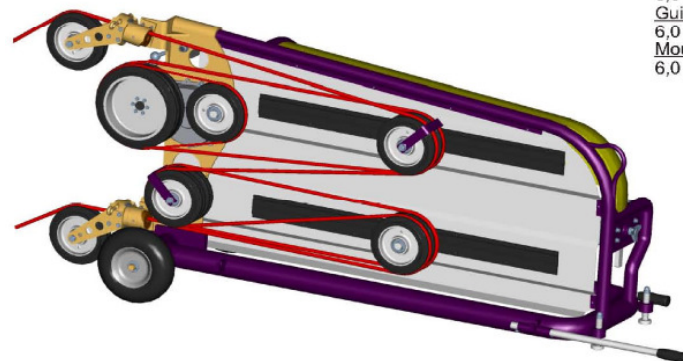

vierfache Belegung:
6,0 bar
Guiding of wire 4:
6,0 bar
Mouflage 4:
6,0 bar

Pict. 4: wire guiding layout

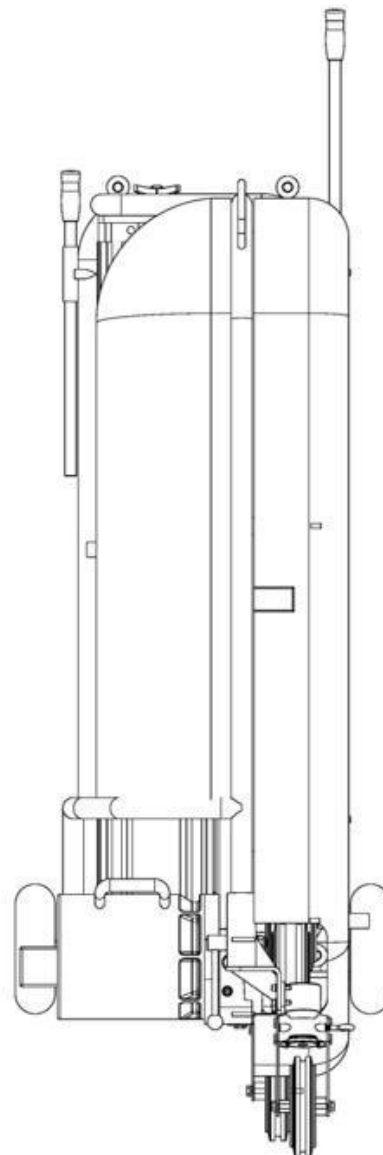
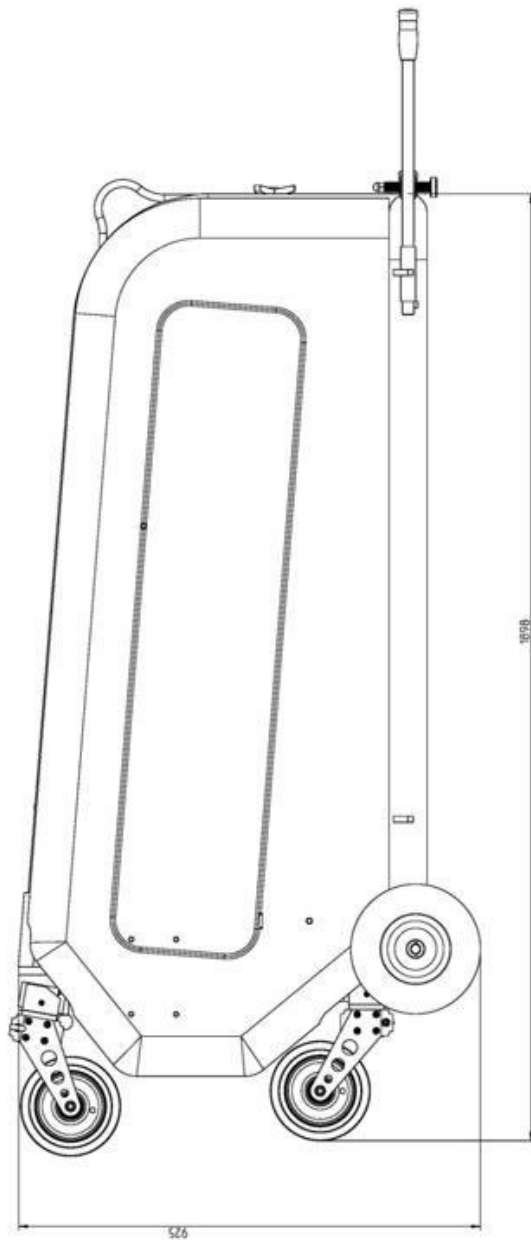
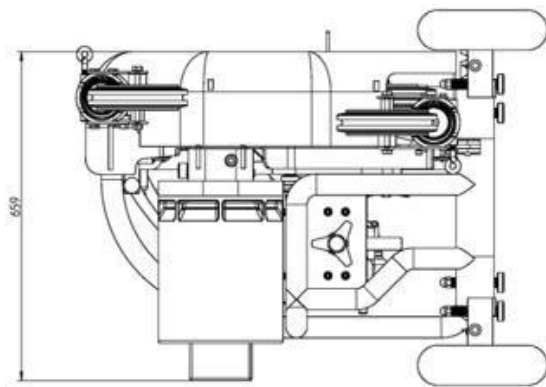

Pict. 5: Views and dimensioning

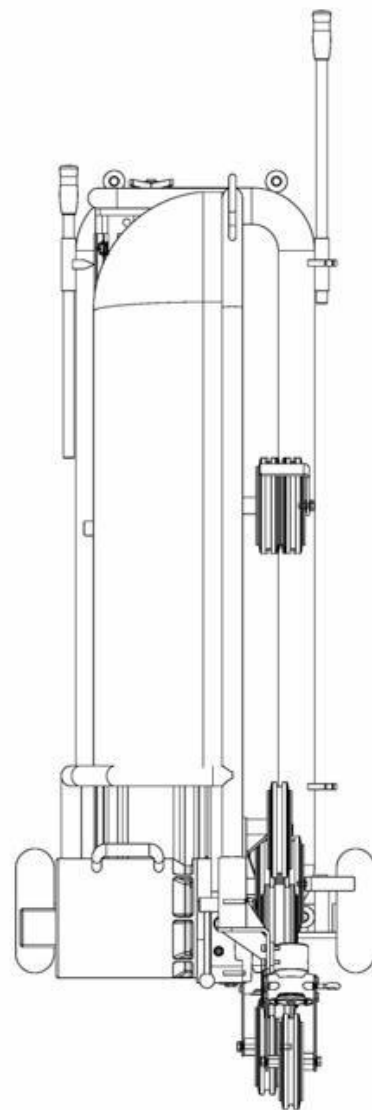
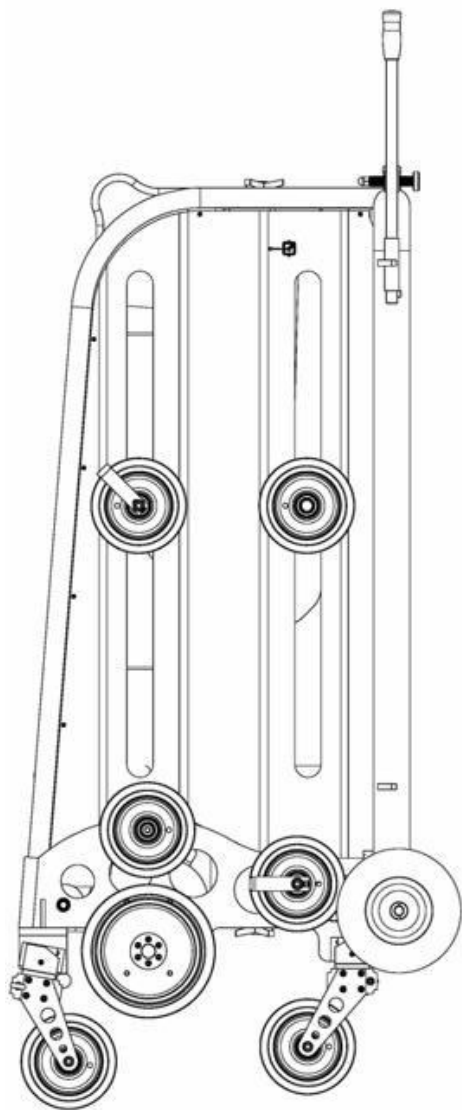
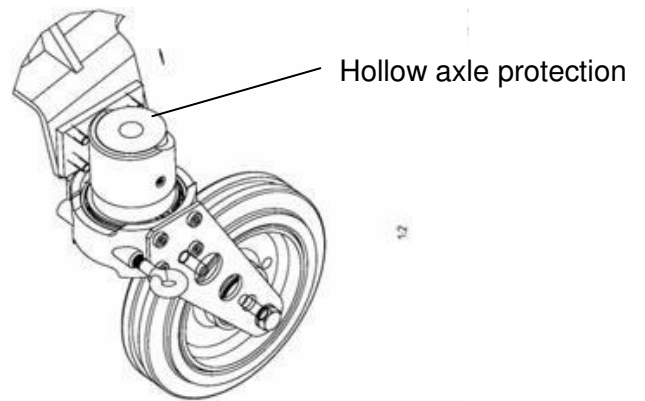
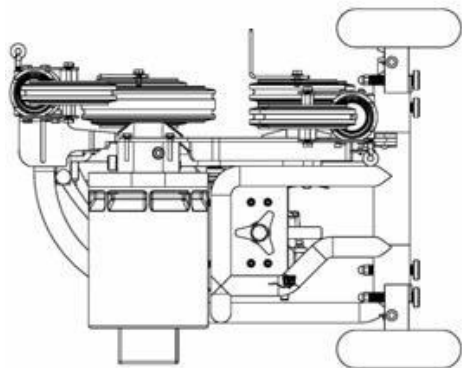

Pict. 6: Views without protection coverings

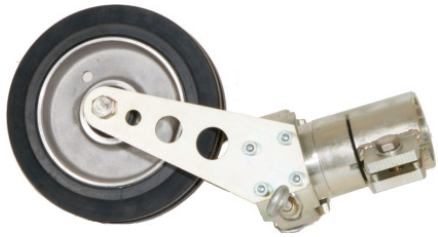

Pict. 7: swivel pulley

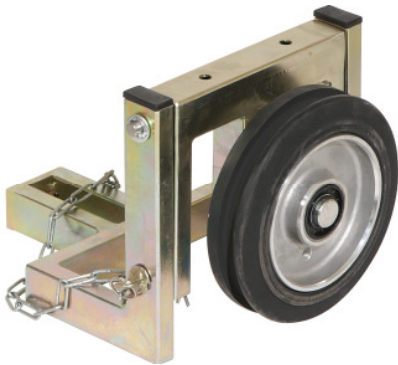

Pict. 8: notching pulley

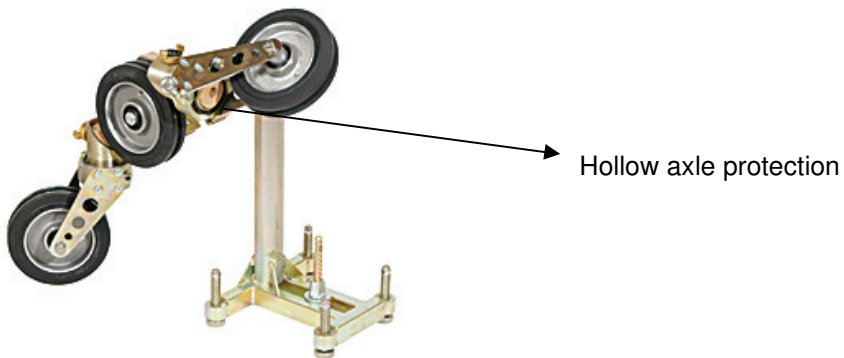

Pict. 9: Wire guiding device



Pict. 10: Plunge saw device



Pict. 11: pipe cutting device

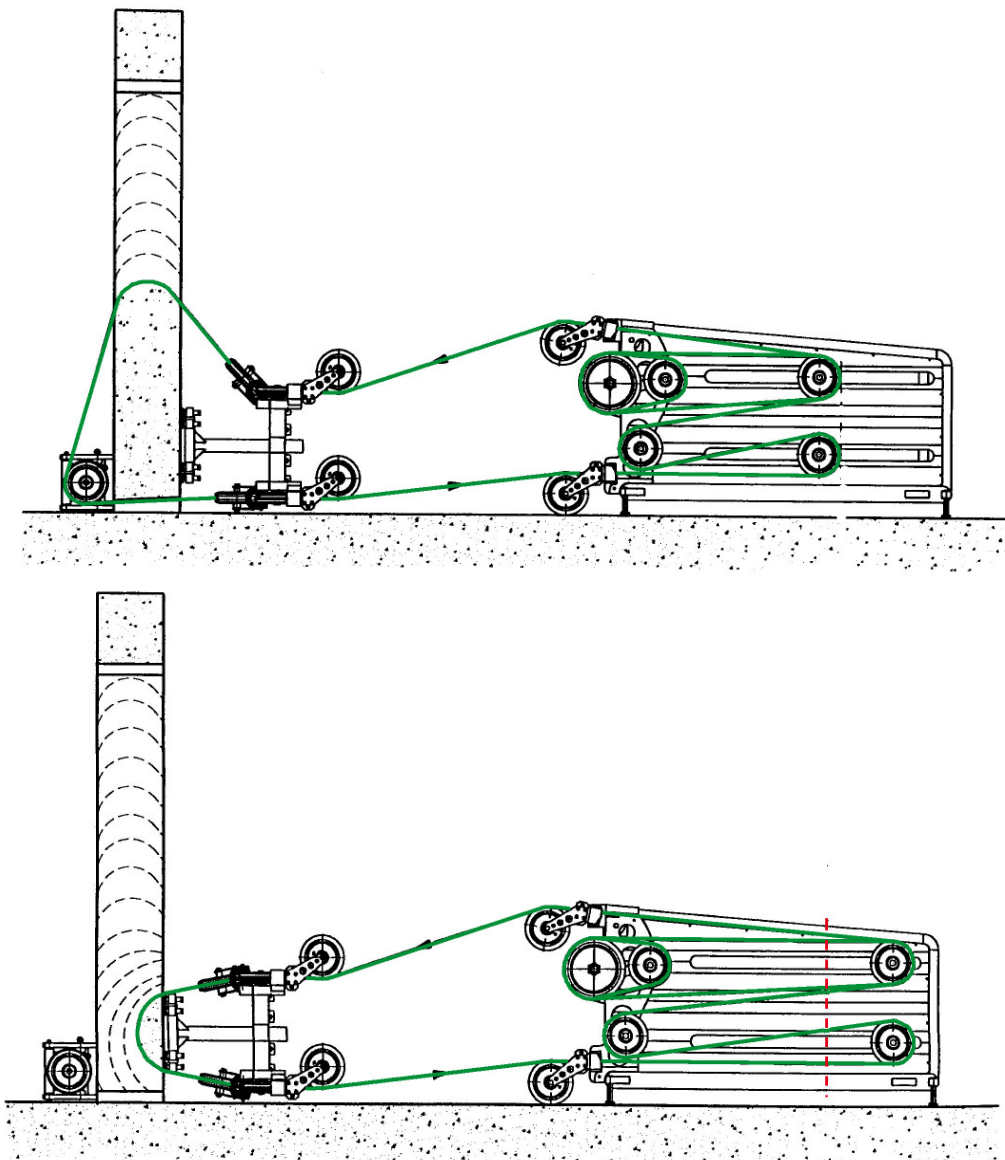

Pict. 12: Mounting at a vertical cut

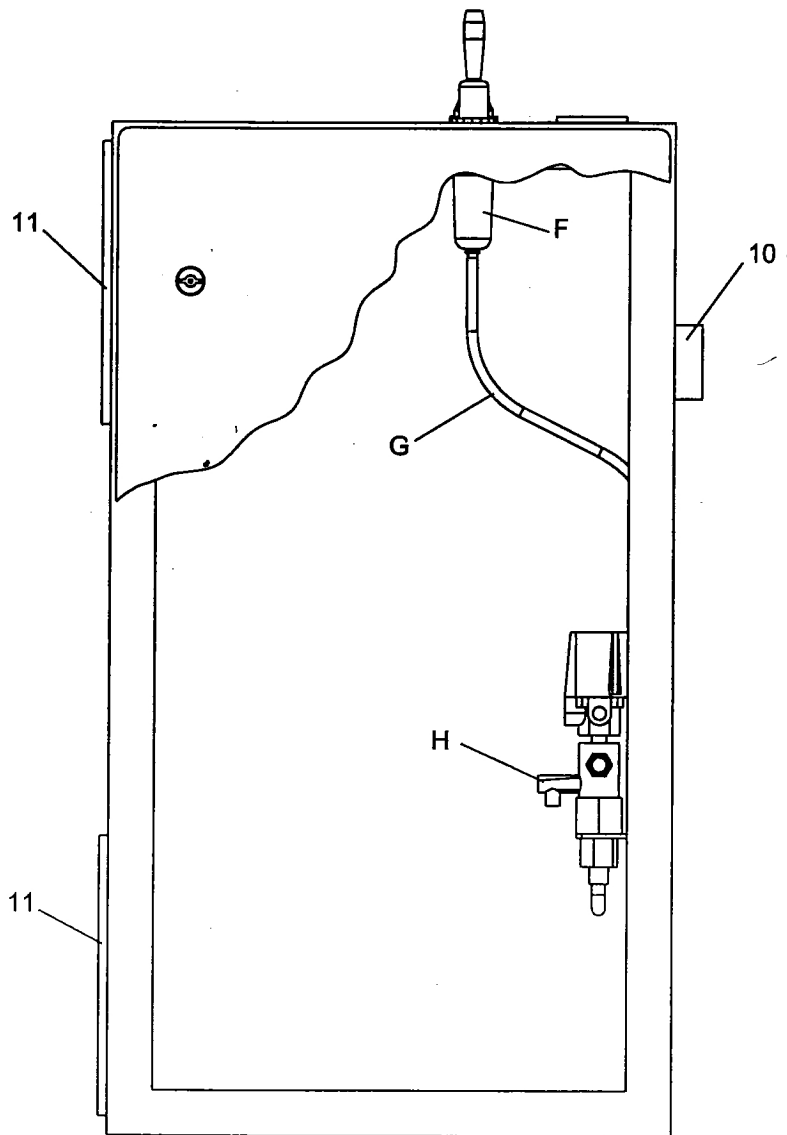

- Pos.A:** Carriage forward – tighten wire
- Pos.B:** Carriage backward – release wire
- Pos.C:** Neutral position – carriage standstill
- Pos.D:** Pressure controller
- Pos.E:** Manometer
- Pos.F:** Drain valve
- Pos.G:** Condensation drainage (lift to drain)
- Pos.H:** Pressure release valve (at power failure, relieve pressure)
- Pos.1:** Button – motor ON
- Pos.2:** Control lamp green – ready for use
- Pos.3:** Control lamp blue – wire storage full
- Pos.4:** Emergency stop button – motor OFF
- Pos.5:** Control lamp yellow – service the machine
- Pos.6:** Control lamp red – fault report
- Pos.7:** Revolution controller
- Pos.8:** Display cutting speed
- Pos.9:** Amperemeter
- Pos.10:** Main switch
- Pos.11:** Air filter

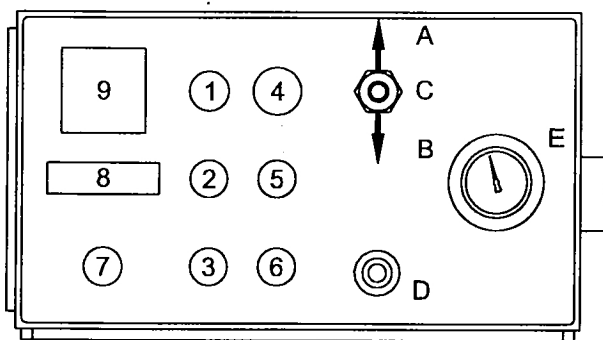

Pict. 13: Control unit – Settings

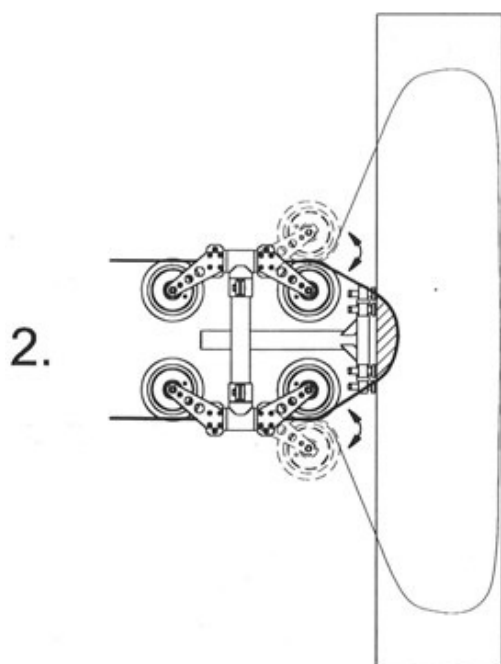
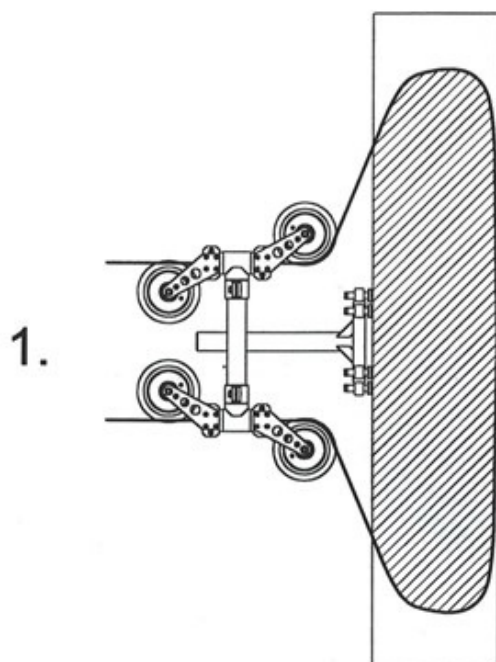

For finishing the cut,
reset the wire pulleys!

Pict. 14: Pulley setting