



For service contact:
German Knife Inc.
1-800-500-3519
www.turboairinc.com

OWNER & OPERATOR INSTRUCTION MANUAL

Model No.

**GS-12A
GS-12M**



IMPORTANT SAFETY NOTICE

To ensure safe and trouble free performance of you new German knife slicer, we suggest that all personnel who will use and maintain the slicer read and understand the manual before operating the equipment. Should there be any questions or if we can be of further assistance, please call us toll free at (800) 500-3519.

TABLE OF CONTENTS

	PAGE
Attention-Warning-Caution	3
Key Components	4
Safety Tips	5
Installation - Proper Grounding	6
Operating Instructions	8
Manual Operation	9
Automatic Operation	10
Cleaning	12
Knife Sharpening	17
Simple Maintenance and Repair	20
Optimal Slicing Performance	22
Troubleshooting Guide	23
Warranty Information	24

German Knife Inc

4184 E. Conant St., Long Beach, CA 90808

Phone : 800-500-3519

Fax : 310-900-1066

www.turboairinc.com

ATTENTION OWNERS AND OPERATORS

German Knife's equipment is designed to provide safe and productive processing of food products as long as the equipment is used in accordance with the instructions in this manual and is properly maintained. Unless the operator is adequately trained and supervised, there is a possibility of **SERIOUS INJURY**. Owners of this equipment bear the responsibility to make certain that this equipment is used properly and safely, strictly following all the instructions contained in this manual and the requirements of local, state or federal law.

Supervisor should not permit anyone to touch this equipment unless they are at least 18 years old, are adequately trained and supervised, and have read and understood this manual. Supervisors should also ensure that no customers, visitors or other unauthorized personnel come in contact with this equipment. Please remember that German Knife cannot anticipate every circumstance or environment in which its equipment will be operated. It is the responsibility of the owner and the operator to remain alert to any hazards posed by the function of this equipment - particularly the sharp knife and all moving parts. If you are uncertain about a particular task or the proper method of operating this equipment, ask your supervisor.

This manual contains a Safety Tips Section listing a number of precautions to follow to help promote safe use of this equipment. Throughout the manual you will see additional warnings to help alert you to potential hazards.

Warning affecting your personal safety are indicated by :



Warning related to possible damage to the equipment are indicated by :



A wall chart, which includes safety instructions, is also included with this equipment.

This wall chart should be posted near the slicer within easy view of the operator. You should also make certain that this manual is available for easy reference by any operator. German Knife has put several warning labels in English on its slicers. Spanish labels are packed in the shipping carton and can replace the English labels at the owner's option. For any warning label copies, please contact your nearest representative or German Knife directly for these items at no charge.

Please remember that this manual, the wall chart, or the warning do not replace the need to be alert, to properly train and supervise operators, and to use common sense when using this equipment.

KEY COMPONENT OF GERMAN KNIFE SLICER

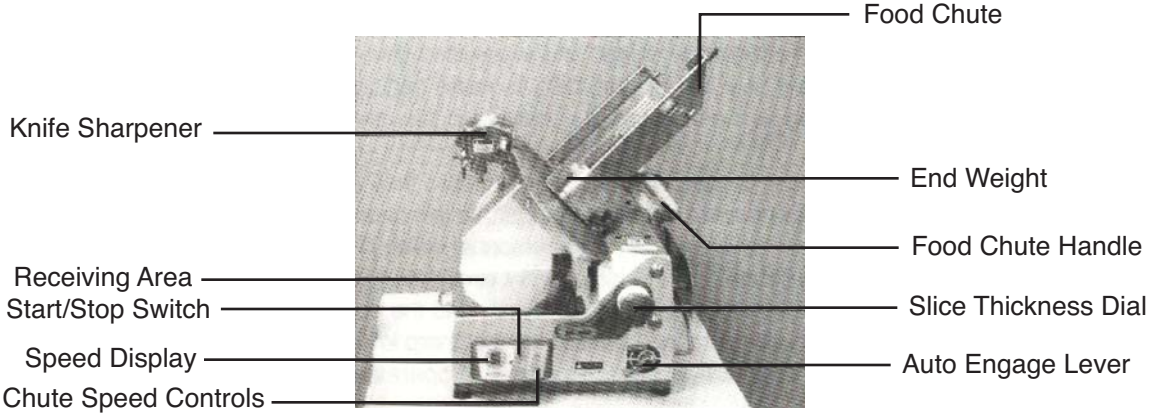

GS-12A FRONT VIEW

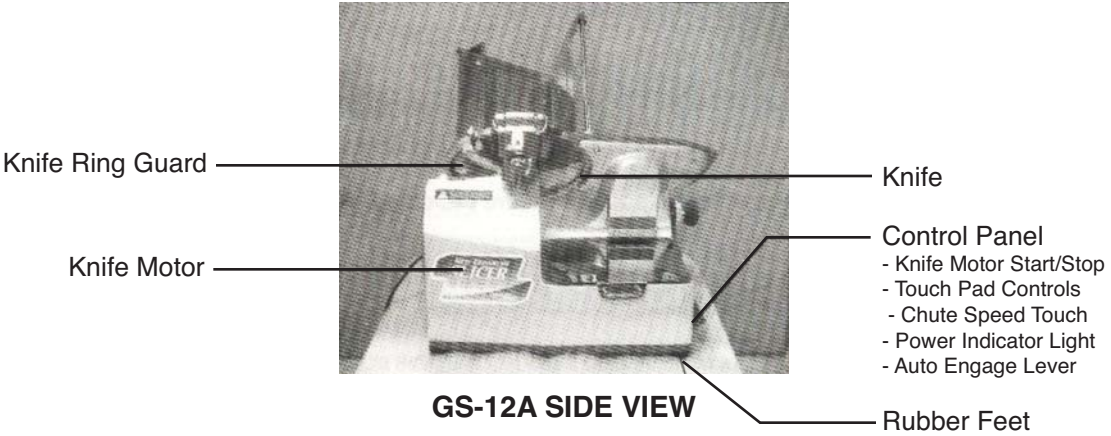

GS-12A SIDE VIEW

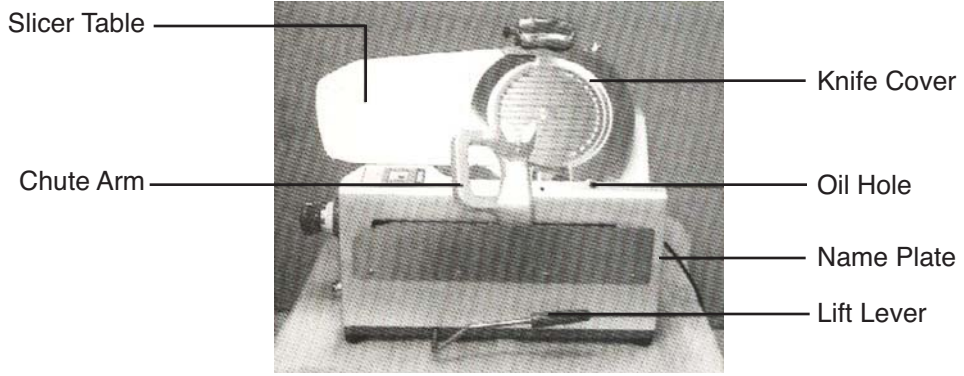

GS-12A SIDE VIEW

KEY COMPONENT OF GERMAN KNIFE SLICER



SHARP KNIFE

TO AVOID SERIOUS PERSONAL INJURY

- **NEVER** touch this machine without training and authorization from your supervisor. You must be at least 18 years old. Read owner and operator manual first.
- **ONLY** install on level non-skid surface in clean ; well-lighted work area away from children / visitors.
- **ALWAYS** ground slicer utilizing proper power source.
- **NEVER TOUCH KNIFE.** Keep hands and arms away from all moving parts.
- **NEVER OPERATE** without knife cover and knife ring guard securely installed.
- **BEFORE TURNING SLICER “ON”**, place auto engage lever in “MANUAL” position. (Automatic slicers only)
- **ONLY USE FOOD CHUTE HANDLE** to push food chute during manual slicing.
- **ONLY USE THE END WEIGHT, NOT YOUR HAND**, to hold food products when slicing. Never put your hand on or around food chute when slicer is on.
- **DO NOT CATCH SLICES WITH YOUR HAND.** Let slices drop on paper-covered receiving area.
- **ALWAYS** turn off slicer, return auto engage lever to “MANUAL” position, and turn slice thickness dial completely clockwise after each use.
- **BEFORE CLEANING, SHARPENING, SERVICING, OR REMOVING ANY PARTS**, always turn slicer off, turn slice thickness dial clockwise to closed position, remove chute unplug slicer.
- **USE ONLY GERMAN KNIFE SLICER ACCESSORIES** properly installed.

UNPACKING

Unpacking the slicer immediately after receipt. If the machine is found to be damaged, save the packaging material and contact the carrier within 24 hours of delivery. Immediately contact the shipper. You have no recourse to damage after 24 hours.

You should receive with the slicer, rubber feet, mineral oil, owner & operator manual and wall chart. Contact German Knife or your supplier if you did not receive all of these materials.



**TO AVOID SERIOUS PERSONAL INJURY
PROPERLY INSTALL SLICER IN ADEQUATE WORK AREA.**

- **ALWAYS** install equipment in work area with adequate light and space.
- **ONLY** operate on a solid, level, non-skid surface.
- **NEVER** bypass, alter, or modify this equipment in any way from its original condition. Doing so may create hazards and void warranty.
- **NEVER** operate slicer without knife cover and knife ring guard securely installed.
- **NEVER** operate without wall chart posted.

INSTALLATION

1. Read this manual thoroughly before installation and operation. **DO NOT** proceed with installation and operation if you have any questions or do not understand anything in this manual. Contact your local representative or German Knife **FIRST**.
2. Remove the corrugated box from your skid by extracting fastener nails at the bottom of the box.
3. Carefully unbolt slicer from bottom of skid using a socket wrench.
4. Attach rubber feet to slicer base and firmly tighten.



**NEVER USE SLICER WITHOUT
RUBBER FEET INSTALLED.**

INSTALLATION

5. Select location for slicer that has a level, solid, non-skid surface and a well-lighted work area away from children and visitors.



USE AT LEAST TWO PEOPLE TO LIFT SLICER UP TO OPERATING LOCATION. NEVER ATTEMPT TO LIFT SLICER ALONE.



THIS MACHINE IS PROVIDED WITH A THREE-PRONG GROUNDING PLUG. THE OUTLET TO WHICH THIS PLUG IS CONNECTED MUST BE PROPERLY GROUNDED. IF THE RECEPTACLE IS NOT THE PROPER GROUNDING TYPE, CONTACT AN ELECTRICIAN. DO NOT UNDER ANY CIRCUMSTANCES CUT OR REMOVE THE THIRD GROUND PRONG FROM THE POWER CORD OR USE ANY ADAPTER PLUG. (SEE FIG. 5-1, 5-2)

6. Post German Knife safety tips and wall chart close by in a location within easy view of operator.

7. Inspect slicer to ensure all parts have been provided.

8. Make sure knife cover, knife ring guard and knife sharpener cover are in place.

9. Make sure warning labels are properly positioned and legible and Owner & Operator Manual is available near slicer. Place the Spanish labels on the slicer if your work force requires them.

10. Complete warranty card and mail to German Knife service center.

11. Clean the slicer using the procedures outlined in the Cleaning Section (page 13 through 16) prior to using the slicer.

12. Contact your local representative or German Knife directly if you have questions or problems regarding the installation or operation of this slicer.



Figure 5-1 Correct



Figure 5-2 Incorrect

OPERATING INSTRUCTIONS



SHARP KNIFE

TO AVOID SERIOUS PERSONAL INJURY

- **NEVER** touch this machine without training and authorization from your supervisor. You must be at least 18 years old. Read owner and operator manual first.
- **NEVER TOUCH KNIFE.** Keep hands and arms away from all moving parts.
- **NEVER OPERATE** without knife cover and knife ring guard securely installed.
- **BEFORE TURNING SLICER “ON”**, place auto engage lever in “MANUAL” position. (Automatic slicers only)
- **ONLY USE FOOD CHUTE HANDLE** to push food chute during manual slicing.
- **ONLY USE THE END WEIGHT, NOT YOUR HAND**, to hold food products when slicing. Never put your hand on or around food chute when slicer is on.
- **DO NOT CATCH SLICES WITH YOUR HAND.** Let slices drop on paper-covered receiving area.
- **ALWAYS** turn off slicer, return auto engage lever to “MANUAL” position, and turn slice thickness dial completely clockwise after each use.
- **BEFORE CLEANING, SHARPENING, SERVICING, OR REMOVING ANY PARTS**, always turn slicer off, turn slice thickness dial clockwise to closed position, remove chute unplug slicer.
- **BE ALERT** that food chute moves back and forth during automatic operation and can move in either direction on start up.

OPERATING INSTRUCTIONS

MANUAL SLICER OPERATION :

1. With slicer off, pull the food chute completely toward you and place the product on the food chute. Slice only boneless unfrozen product with the slicer. Use the end weight to hold the food product in place. If the end weight is not needed, it may be stored out of the way by swing it forward behind the food chute and locking it on the retaining slot.
2. Make sure all knobs are tightened prior to using the slicer.
3. Make sure the Auto Engage Lever is in the “MANUAL” position. (Automatic units only)
4. Rotate the slice thickness dial counterclockwise to desired slice thickness. After slicing is complete, always turn slice thickness dial completely clockwise to close slicer table.
5. Turn slicer on by pressing the on/off switch button. The power indicator light will illuminate.



DO NOT hold the food product with your hand. Never put your hand on or around food chute when slicer is on. The food chute handle is the only part of the slicer you should touch while slicing.

6. Use the food chute handle to manually push the food chute back and forth. The food chute handle is the only part of the slicer you should touch while slicing. Do not catch slices with your hand. Let slices drop on paper covered receiving area.



If a product needs to be adjusted during slicing, turn off the slicer. Pull the food chute all the way towards you and close slicer thickness table prior to adjusting the product and the end weight.

7. After the last slice stroke, pull food chute all the way toward you and turn the slicer off by pressing the on/off switch button. The power indicator light will go out. Always turn slice thickness dial completely clockwise to close the slicer table.
8. Now you can remove the product from the food chute.

MANUAL USE OF AUTOMATIC SLICER



ALWAYS make sure the auto engage lever is in the “MANUAL” position before turning slicer “ON”.

Automatic slicer can be used manually when desired. When manually operating an automatic slicer, the auto engage lever **MUST** be in the “MANUAL” position before turning the slicer “ON” (Fig 7-1). The lever should not be moved out of the “MANUAL” position at any time during use. Turn the slicer on by pressing the start button.



Fig 7-1

OPERATING INSTRUCTIONS



AUTOMATIC SLICER OPERATION :



BEFORE using the slicer in automatic, MAKE SURE that Auto Engage Lever in the “MANUAL” position

1. Make sure the slicer is turned “OFF”. Make sure Auto Engage Lever is in “MANUAL” position, the slicer thickness knob should be turned all the way clockwise and the food chute should move freely.
2. Pull the food chute completely toward you and load the food product. Swing end weight into position to secure food product.
3. If food product is too long, place end weight on top of the food product and use the end weight prongs to hold the food product in place.
4. Auto Engage Lever must be in “MANUAL” position to start the slicer.
5. Press start button, the power indicator light will illuminate. The speed indicator light will flash “4” if the start button is pressed when the Auto Engage Lever is in the automatic position. Lower the Auto Engage Lever to the “MANUAL” position and start the unit.



Fig 8-1



BE ALERT. The next step will cause the food chute to move automatically and it can move either direction on start up.

6. To make the food chute move automatically, move Auto Engage Lever into “AUTOMATIC” position (Fig. 8-1).
 - Model GS-12A - To adjust the chute speed press the slower or faster buttons (Fig 8-2). The slicer defaults to speed 5 when slicer is unplugged and plugged back in. If slicer is turned off but not unplugged it will return to the most recent speed used.

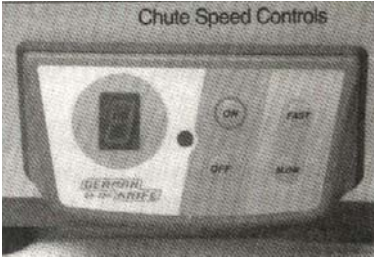

Fig 8-2



Never attempt to adjust, load or unload food chute when slicer is in the automatic mode.

NOTE : Chute speed can be adjusted prior to or after auto engagement.

OPERATING INSTRUCTIONS

7. To stop the auto drive only - Turn the Auto Engage Lever to the “MANUAL” position.



CAUTION : The knife is still rotating even though the chute has stopped.

8. To turn slicer completely off and stop the knife, press the stop button. Press the Auto Engage Lever down to “MANUAL” position.

9. Using the Food Chute Handle, pull the food chute all the way toward the operator. Turn slice thickness dial all the way clockwise to close the slicer table. Now you can load and unload the product.

10. When finished using slicer, make sure slicer is turned “OFF”, the slice thickness dial is turned completely clockwise and the Auto Engage Lever is in the “MANUAL” position.

AUTOMATIC SLICER OPERATION :

MODEL #	STROKES PER MINUTES	VARIABLE
GS-12A	20 - 60	9 SPEED VARIABLE

CLEANING



SHARP KNIFE

TO AVOID SERIOUS PERSONAL INJURY

- **BEFORE CLEANING, SHARPENING, SERVICING, OR REMOVING ANY PARTS**, always turn slicer off, turn slice thickness dial all the way clockwise, remove chute and unplug slicer.
- **NEVER** attempt to clean slicer with the knife running.
- **NEVER** attempt to remove knife or knife ring guard for cleaning.

Your slicer should be cleaned and sanitized as often as necessary or at least once per day. Slicer components are easily disassembled without the use of special tools.

NOTE : It may be desirable to wear cut resistant glove during the cleaning operation.

CLEANING

DISASSEMBLY & CLEANING :

1. Turn slice off.
2. Close thickness dial.
3. FOOD CHUTE : Remove the food chute by loosening the food chute release knob that fastens the food chute to the chute arm. Lift the food chute off the chute arm.
4. Unplug slicer.



BE ALERT. THE NEXT STEPS WILL EXPOSE THE KNIFE.

5. Lift knife sharpener cover.
6. KNIFE COVER : While holding the knobs on the knife cover, pull up on the top spring loaded knob and lift upward to move (Figs.11-1, 11-2). Slicer will not start with knife cover removed.



Fig. 11-1



Fig. 11-2



NEVER ATTEMPT TO REMOVE OR DISMANTLE THE KNIFE RING GUARD.



NEVER TRY TO REMOVE THE KNIFE FROM THE SLICER. IT MUST REMAIN ON THE SLICER FOR PROPER OPERATION, SHARPENING, AND CLEANING.

CLEANING



- DO NOT put components in dishwasher.
- Dilute detergent per supplier's instruction.
- DO NOT hose down or pressure wash any part of the slicer.
- NEVER use scrubber pad, steel wool, or abrasive material to clean the slicer.
- NEVER remove sharpener from slicer or immerse in water.
- Clean the disassembled components with a mild detergent and warm water solution. Allow parts to air dry.



ALWAYS TURN OFF SLICER AND UNPLUG POWER CORD BEFORE CLEANING.

7. The knife ring guard must now be cleaned. To clean the knife ring guard, soak a clean cloth in a mild detergent and warm water solution. Ring out excess water from cloth. Carefully insert the cloth between the knife and the knife ring guard as indicated by Fig.12-1. While holding the cloth between the knife and the knife ring guard, work it along the entire back side of the knife, between the knife and knife ring guard. Repeat this procedure as necessary. A nylon brush could also be used if preferred.

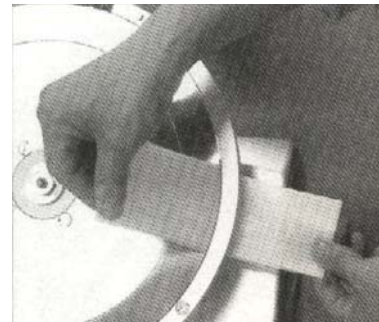

Fig. 12-1

8. The knife must also be cleaned. Carefully wash and rinse the top and bottom surface of the knife by wiping from the center of the knife outward as indicated in Fig.12-2.

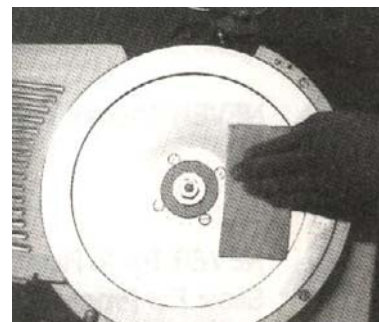

Fig. 12-2

CLEANING



DO NOT ALLOW MOISTURE TO GET INTO KNIFE HUB.

9. Now replace the knife cover on top of the knife. Align the bottom notches of the knife cover with the knobs located at the bottom of the knife ring guard (Fig.13-1). The top right of the knife cover also has a hole that fits over a locator pin at the top of the knife ring guard.

NOTE : The slicer will not operate unless the knife cover is in place and secure.



Fig. 13-1

10. Lower the knife sharpener cover.

11. With the slicer table completely closed, wipe the slicer table off by starting at the knife and pulling towards you. Never wipe the slicer table toward the knife.

12. Clean and wipe down the entire slicer. Use a mild sanitizer if required.



DO NOT USE CAUSTIC OR STRONG DETERGENTS ON THE SLICER BASE OR COMPONENTS.

CLEANING

REASSEMBLY :

1. Install food chute to the original position on the chute arm.
Tighten food chute release knob securely to prevent any “play” between the food chute and chute arm.

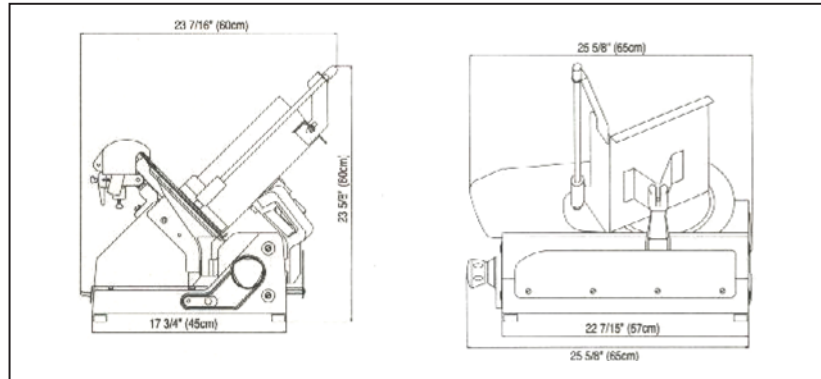

Fig. 14-1

2. Some manual slicers are equipped with a cleaning brace which raises the slicer to allow cleaning underneath. Push the food chute to the back of the slicer. Simply lift up the front of the slicer and pull the brace completely toward the front of the slicer and lower the unit. (Fig.14-1)

3. Some automatic slicers have a lift lever which raises the slicer to allow cleaning underneath. To clean under a slicer equipped with a lift lever :

(a) With the Auto Engage Lever in “MANUAL” position, push the food chute to the back of the slicer.

(b) Pull the lift lever knob toward operator with your right hand, while gently lifting up on the slice thickness dial with the other (Fig.14-2)

(c) Pull the lift lever all the way forward toward operator until it stops (Fig.14-3)

4. After cleaning the counter area under the slicer, lower slicer back to its operating position.

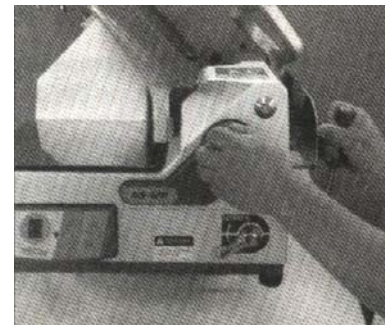

Fig. 14-2



Fig. 14-3

KNIFE SHARPENING



SHARP KNIFE TO AVOID SERIOUS PERSONAL INJURY

- **NEVER** touch rotating knife.
- **ALWAYS** keep hands clear of all moving parts.
- **ALWAYS** turn off slicer, return Auto Engage Lever to “MANUAL” position, turn slice thickness dial completely clockwise and remove food chute before sharpening.
- **NEVER** sharpen slicer unless all guards are installed.
- **ALWAYS** make sure food chute is removed and Auto Engage Lever is in “MANUAL” position when sharpening automatic slicer.

GENERAL :

1. Symptoms of a dull knife are excess waste/or “tail” on the unsliced portion remaining in the food chute.
2. The knife needs to be sharpened periodically to provide consistent slices and maximum food product yield. Sharpening the knife lightly every few days is more efficient than heavy sharpening at less frequent intervals.

KNIFE SHARPENING

PREPARING TO SHARPEN :



Turn slicer off by pressing the stop button (Automatics only) or by pushing the on/off tab inward.



Make sure Auto Engage lever is in "MANUAL" position. (Automatics units only)

1. Turn slice thickness dial completely clockwise so that slicer table covers knife edge.
2. Remove food chute from slicer.
3. Clean and dry both sides of the knife before sharpening, following instructions for knife cleaning on pages 12 thru 16.



BE ALERT. The next steps will expose the knife.

4. Expose sharpener stones by lifting the knife sharpener cover (Figs.16-1,16-2). Stones should be clean, dry and free of dirt and grease.



ALWAYS keep hands and arms away from exposed knife. Make sure slicers have the food chute removed.



Fig.16-1



Fig.16-2

KNIFE SHARPENING

SHARPENING THE KNIFE :

1. Pull on knob #1 (Fig.17-1) keeping it extended. Also, hold onto lever #2 and swing sharpener in position by lifting upward.
2. Pull out knob #3 (Fig.17-2)
3. Turn knife motor on by pressing the start button. Push the lever counterclockwise (Fig.17-3) to bring stones into contact with the knife. Maintain pressure on the handle for 5-10 seconds. Be sure both stones are in contact with knife. Repeat operation until knife is sharp.

NOTE : If knife becomes very dull, activate only the bottom stone by pushing in knob #3 (Fig.17-2). When sharpening with the bottom stone is completed, pull out knob #3 (Fig.17-2). This allows simultaneous sharpening with both stones. Always finish sharpening using both stone.



TURN OFF Slicer before inspecting.

FINISH SHARPENING :

When sharpening is finished, follow these procedures:

1. Turn the slicer off by pressing the stop button (automatics only) or by pressing the on/off switch button. Unplug the power cord.
2. Return the sharpener to its original position by pulling on knob (#1) keeping it extended. Also, hold onto lever #2 and swing sharpener back in to stored position. (Fig.17-4)
3. If sharpening stones need to be cleaned, use alcohol and a brush. Dry stones afterwards.
4. Close sharpener cover.
5. Clean slicer as necessary using cleaning procedures listed on pages 12 thru 16.
6. Plug in slicer.
7. Re-install food chute on slicer.

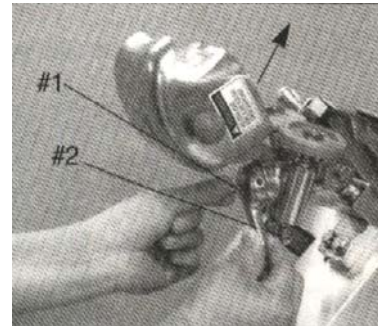

Fig.17-1

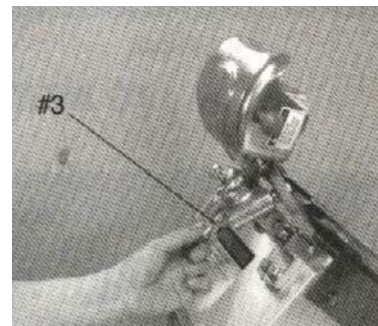

Fig.17-2

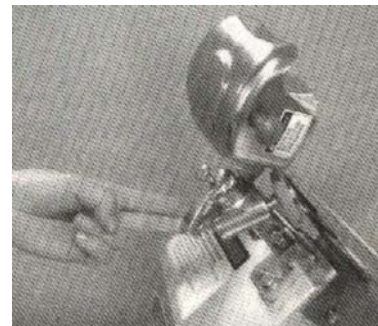

Fig.17-3

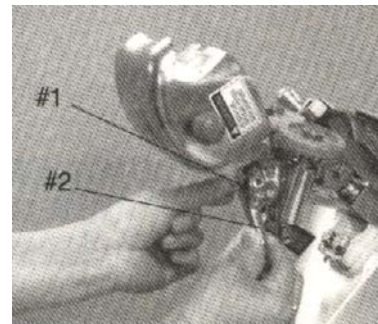

Fig.17-4

SIMPLE MAINTENANCE AND REPAIR



SHARP KNIFE TO AVOID SERIOUS PERSONAL INJURY

- **BEFORE CLEANING, SHARPENING, SERVICING, OR REMOVING ANY PARTS**, always turn slicer off, turn slice thickness dial all the way clockwise, remove chute and unplug slicer.
- **NEVER** touch this machine without training and authorization from your supervisor. You must be at least 18 years old. Read owner and operator manual first.
- **NEVER TOUCH KNIFE**. Keep hands and arms away from all moving parts.
- **DO NOT** temper with bypass or remove any safety devices, guards or touch pad controls.
- **ALWAYS** turn off slicer, return auto engage lever to “MANUAL” position, and turn slice thickness dial completely clockwise after each use.
- **USE ONLY GERMAN KNIFE SLICER ACCESSORIES** properly installed.

LUBRICATION :

Various slicer parts need to be lubricated periodically using mineral oil. German Knife oil is a light, tasteless and odorless mineral oil that will not contaminate or impart odors or taste to the sliced product.



**DO NOT USE VEGETABLE OIL TO LUBRICATE SLICER.
VEGETABLE OIL WILL DAMAGE THE SLICER.**

SIMPLE MAINTENANCE AND REPAIR

1. Chute Slide Rods

It is necessary to lubricate the food chute slide rods with mineral oil weekly or when it is hard to push.

- A. Close slicer table.
- B. Pull food chute handle completely forward (toward operator (Fig.19-1)
- C. Remove cap from oil container. Add several drops of mineral oil into the oil hole.
- D. Move the chute back and forth to spread oil on slide rods underneath.
- E. Wipe off excess oil.



Fig. 19-1

2. End Weight Slide Rod

- A. The end weight slide rod(#1) (Fig.19-2) should be lubricated as needed with a few drops of mineral oil.

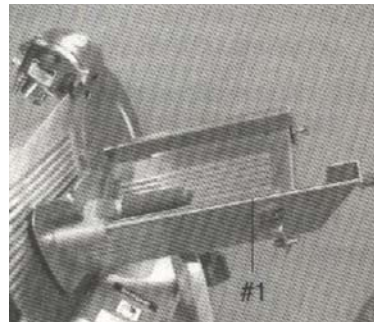

Fig. 19-2

3. Sharpener

- A. The sharpener shafts should be lubricated once per month with a few drops of mineral oil.
- B. Add mineral oil to each of the sharpener shaft (behind the stone) where the shaft enters the sharpener housing.

4. Other Lubrication

It is recommended that all threaded screws be lubricated after each cleaning to maximize the life of your slicer.

OPTIMAL SLICING PERFORMANCE

TO OBTAIN THE MAXIMUM PERFORMANCE AND YIELD FROM YOUR GERMAN KNIFE SLICER :

1. Read this entire manual before touching slicer and strictly follow all instructions and precautions. THERE IS NO SUBSTITUTE FOR SAFETY!
2. Lubricate the slicer per the instruction on page 21.
3. Maintain a sharp knife and replace as necessary. Never attempt to replace the knife yourself. We recommend replacing the knife at 11-1/4" diameter. (New knife is 11-7/8")
4. Clean knife prior to sharpening slicer.
5. As the knife is sharpened and the diameter is reduced.
 - a) It will be necessary to have the table adjusted inward toward the knife in order to maintain a consistent 1/32" clearance between the table and knife.
 - b) It will be necessary to have the sharpener assembly adjusted lower to maintain proper alignment with the knife.

We recommend an authorized German Knife Service Company to perform all adjustments and preventive maintenance.

By adequately maintaining your slicer, it will provide years of dependable service. The only way to damage a German Knife slicer is by neglect.

TROUBLESHOOTING GUIDE

SYMPTOM	POSSIBLE CAUSE	POSSIBLE SOLUTION
Slicer will not start	Slicer not plugged in breaker tripped	Plug-in slicer Re-set breaker at power box
Chute speed light flashing "1"	Knife cover removed or not properly installed	Install knife cover
The power indicator light will flash (Manual type).	Knife cover removed or not properly installed	Install knife cover
Chute speed light flashing "2"	Chute DC motor overheated	Press stop button to remove flashing "2", wait 10 min, and restart slicer.
Chute speed light flashing "3"	Chute DC motor over current	Remove an obstacle on slicer and restart slicer
Chute speed light flashing "4"	Auto engage lever in automatic	Move lever to manual position and restart slicer
Chute speed light flashing "5"	Blade AC motor overheated	Call for service center to repair blade AC motor
Ragged cuts-poor yield	Dull knife	Sharpen knife and make sure knife and stones are clean
	Chipped knife	Sharpen or have new knife installed
	Knife slicer table gap too wide knife too small 11-1/4" or less	Call for service to adjust slicer table. Have new knife installed.
Metal rubbing knife	Knife cover	Make sure knife cover is properly installed
	Food chute End weight Slicer thickness table	Tighten or adjust food chute Have defective end weight replaced Call for service to adjust slicer table
Automatic food chute won't move. NOTE : Knife motor must be ON in order for chute motor to start.	Auto engage mechanism jammed	Place auto engage lever in "MANUAL". Re-engage auto-matic when machine is running
Hard to push food chute	No lubrication	Lubricate side rods thoroughly with mineral oil
Hard to sharpen	Stone dirty, wet or clogged with grease	Clean stones with alcohol and brush. Dry stones afterwards
	Knife dirty	Clean top and bottom of knife
	Worn stones	Have stones replaced
	Stones not properly aligned	Have sharpener adjusted

LIMITED WARRANTY

WARRANTY CLAIM:

German Knife / Radiance warrants that the equipment, as supplied from the factory to the end-user, is free from defects in materials and workmanship. Should any part be found defective resulting from normal use within the defined warranty period, German Knife / Radiance will gladly dispatch an authorized service agency to repair and/or replace necessary parts under the following conditions.

Repairs under this warranty are to be performed by a German Knife / Radiance authorized service agency only. German Knife / Radiance will not be responsible for service parts and labor charges performed by non-authorized service companies. All claims should include the model number, serial number, proof of purchase, date of installation, and all pertinent information supporting the alleged defect.

PRODUCTS UNDER WARRANTY:

One Year Warranty:

- Radiance Medium Duty Microwaves- ER/MR series (TMW-1100ER, TMW-1100MR)
- Radiance Ranges & Countertop cooking series
(All TAR-, TARG-, TAHP-, TARB-, TAMG-, TATG-, TASP-, TAWR-)
- Radiance Cheesemelters, Salamanders, Steam Tables, Hand Wrappers, and Food Warmers
(All TACM-, TASM-, RST-, RHW-, RFW-)
- German Knife Light Duty Slicer- LD series (GS-10LD, GS-12LD)

Two Year Warranty:

- German Knife Heavy Duty Meat Slicer- Automatic & Manual (GS-12A, GS-12M, GS-13A, GS-13M)
- German Knife Meat Grinder (All GG-)
- German Knife Band Saw (All GBS-)

Three Year Warranty:

- Radiance Heavy Duty Microwaves- HD Series (TMW-1200HD, TMW-1800HD)

Any part covered under this warranty that is found by German Knife / Radiance to have been defective within the above time period is limited to the repair or replacement, including labor charges, of defective parts or assemblies. The labor charges shall include standard straight time labor charges only and reasonable travel time as determined by German Knife / Radiance.

WHAT IS NOT COVERED BY THIS WARRANTY:

German Knife / Radiance's sole obligation under this warranty is limited to either repair or replacement of parts, subject to the additional limitations below. This warranty neither assumes nor authorizes any person to assume obligations other than those expressly covered by this warranty.

- Equipment failure resulting from improper installation will not be honored under warranty. Examples are wrong utility connection and improper utility supply problems.
- Equipment that has not been maintained accordingly. Examples are calibration of controls, adjustment to pilots and burners, and damage from improper cleaning.
- Equipment that has not been used in an appropriate manner, alteration, neglect, abuse, misuse, accident, damage during transit or installation, fire, food, acts of God.
- Warranty is not transferrable and only applies in favor of the original purchaser.
- Equipment failure resulting from electrical power failure, use of extension cords, low voltage, and voltage drops to the unit.

These warranties are exclusive and in lieu of all other warranties, including implied warranty and merchantability or fitness for a particular purpose. No consequential damages. German Knife / Radiance is not responsible for economic loss, profit loss or special, indirect, or consequential damages. There are no warranties which extend beyond the description on the face hereof.

Outside the U.S., this warranty does not apply to, and German Knife / Radiance is not responsible for, any warranty claims made on products sold or used outside the continent of the United States.