

©2014 ADJ Products, LLC all rights reserved. Information, specifications, diagrams, images, and instructions herein are subject to change without notice. ADJ Products, LLC logo and identifying product names and numbers herein are trademarks of ADJ Products, LLC. Copyright protection claimed includes all forms and matters of copyrightable materials and information now allowed by statutory or judicial law or hereinafter granted. Product names used in this document may be trademarks or registered trademarks of their respective companies and are hereby acknowledged. All non-ADJ Products, LLC brands and product names are trademarks or registered trademarks of their respective companies.

**ADJ Products, LLC** and all affiliated companies hereby disclaim any and all liabilities for property, equipment, building, and electrical damages, injuries to any persons, and direct or indirect economic loss associated with the use or reliance of any information contained within this document, and/or as a result of the improper, unsafe, insufficient and negligent assembly, installation, rigging, and operation of this product.

## User Instructions

Europe Energy Saving Notice

Energy Saving Matters (EuP 2009/125/EC)

Saving electric energy is a key to help protecting the environment. Please turn off all electrical products when they are not in use. To avoid power consumption in idle mode, disconnect all electrical equipment from power when not in use. Thank you!

## Zipper

## General Information

**Unpacking:** Thank you for purchasing the Zipper by ADJ Products, LLC. Every Zipper has been thoroughly tested and has been shipped in perfect operating condition. Carefully check the shipping carton for damage that may have occurred during shipping. If the carton appears to be damaged, carefully inspect your fixture for any damage and be sure all equipment necessary to operate the unit has arrived intact. In the event damage has been found or parts are missing, please contact our toll free customer support number for further instructions. Please do not return this unit to your dealer without contacting customer support first.

**Introduction:** The Zipper is a DMX intelligent LED quad barrel roller. The Zipper has three operating modes; a sound active, show mode, DMX controlled. The Zipper has 3 DMX mode; 1 channel mode, 3 channel mode, and 11 channel mode. The Zipper can operate as a stand alone fixture or in a Master/Slave configuration. *For best results use fog or special effects smoke to enhance the beams projections.*

**Customer Support:** ADJ Products, LLC provides a toll free customer support line, to provide help and to answer any question should you encounter problems during your set up or initial operation. You may also visit us on the web at [www.adj.com](http://www.adj.com) for any comments or suggestions. Service Hours are Monday through Friday 8:00 a.m. to 4:30 p.m. Pacific Standard Time.

Voice: (800) 322-6337

Fax: (323) 582-2941

E-mail: [support@americandj.com](mailto:support@americandj.com)

To purchase parts online visit <http://parts.americandj.com>

**Warning!** To prevent or reduce the risk of electrical shock or fire, do not expose this unit to rain or moisture.

**Warning!** *This may cause severe eye damage. Avoid looking directly into the light source at all times!*

## Zipper

## General Instructions

To optimize the performance of this product, please read these operating instructions carefully to familiarize yourself with the basic operations of this unit. These instructions contain important safety information regarding the use and maintenance of this unit. Please keep this manual with the unit, for future reference.

## Zipper

## Features

- 3 DMX Modes: 1 Channel, 3 Channel, and 11 Channel
- 3 Operating Modes - Sound Active, Show Mode, & DMX Control
- Internal Microphone
- Digital Display for Address and Function Setting
- 16 Preprogrammed Shows
- Power Cord Daisy Chain (See page 21)
- UC IR Compatible (Sold Separately)

## Zipper

## Warranty Registration

The Zipper carries a 2 year (730 days) limited warranty. Please fill out the enclosed warranty card to validate your purchase and warranty. You may also register your product online at [www.americandj.com](http://www.americandj.com). All returned service items whether under warranty or not, must be freight pre-paid and accompany a return authorization (R.A.) number. If the unit is under warranty you must provide a copy of your proof of purchase invoice. Please contact ADJ customer support for a R.A. number.

## Zipper

## Handling Precautions

**Caution!** There are no user serviceable parts inside this unit. Do not attempt any repairs yourself, doing so will void your manufactures warranty. In the unlikely event your unit may require service please contact ADJ Products, LLC.

*During operation the housing may become extremely hot. Avoid touching the unit with bare hands while in use.*

*ADJ Products, LLC will not accept any liability for any resulting damages caused by the non-observance of this manual or any unauthorized modification to this unit.*

***For Your Own Personal Safety, Please Read and Understand This Manual Completely Before You Attempt To Install Or Operate This Unit!***

- To reduce the risk of electrical shock or fire, do not expose this unit rain or moisture
- Do not spill water or other liquids into or on to your unit.
- Do not attempt to operate this unit if the power cord has been frayed or broken.
- Do not attempt to remove or break off the ground prong from the electrical cord. This prong is used to reduce the risk of electrical shock and fire in case of an internal short.
- Disconnect from main power before making any type of connection.
- Do not remove the cover under any conditions. There are no user serviceable parts inside.
- Never operate this unit when it's cover is removed.
- Always be sure to mount this unit in an area that will allow proper ventilation. Allow about 6" (15cm) between this device and a wall.
- Do not attempt to operate this unit, if it becomes damaged.
- This unit is intended for indoor use only, use of this product outdoors voids all warranties.
- Always mount this unit in safe and stable matter.
- Power-supply cords should be routed so that they are not likely to be walked on or pinched by items placed upon or against them, paying particular attention to cords at plugs, convenience receptacles, and the point where they exit from the appliance.
- Cleaning -The fixture should be cleaned only as recommended by the manufacturer. See page 22 for cleaning details.
- Heat -This fixture should be situated away from heat sources such as radiators, heat registers, stoves, or other appliances (including amplifiers) that produce heat.
- The fixture should be serviced by qualified service personnel when:
  - A. Objects have fallen, or liquid has been spilled into the appliance.
  - B. The appliance has been exposed to rain or water.
  - C. The appliance does not appear to operate normally or exhibits a marked change in performance.

**Power Supply:** The ADJ Zipper contains a automatic voltage switch, which will auto sense the voltage when it is plugged into a power source. With this switch there is no need to worry about the correct power voltage, this unit can be plugged in anywhere.

**DMX-512:** *DMX is short for Digital Multiplex. This is a universal protocol used by most lighting and controller manufactures as a form of communication between intelligent fixtures and controllers. A DMX controller sends DMX data instructions from the controller to the fixture. DMX data is sent as serial data that travels from fixture to fixture via the DATA "IN" and DATA "OUT" XLR terminals located on all DMX fixtures (most controllers only have a DATA "OUT" terminal).*

**DMX Linking:** DMX is a language allowing all makes and models of different manufactures to be linked together and operate from a single controller, as long as all fixtures and the controller are DMX compliant. *To ensure proper DMX data transmission, when using several DMX fixtures try to use the shortest cable path possible. The order in which fixtures are connected in a DMX line does not influence the DMX addressing. For example; a fixture assigned a DMX address of 1 may be placed anywhere in a DMX line, at the beginning, at the end, or anywhere in the middle. Therefore, the first fixture controlled by the controller could be the last fixture in the chain. When a fixture is assigned a DMX address of 1, the DMX controller knows to send DATA assigned to address 1 to that unit, no matter where it is located in the DMX chain.*

**Data Cable (DMX Cable) Requirements (For DMX and Master/Slave Operation):** The Zipper can be controlled via DMX-512 protocol. The Zipper has 3 DMX modes. The DMX address is set electronically using the controls on the rear panel of the unit. Your unit and your DMX controller require a approved DMX-512 110 Ohm Data cable for data input and data output (Figure 1). We recommend Accu-Cable DMX cables. If you are making your own cables, be sure to use standard 110-120 Ohm shielded cable (This cable may be purchased at almost all professional sound and lighting stores). Your cables should be made with a male and female XLR connector on either end of the cable. Also remember that DMX cable must be daisy



Figure 1

chained and cannot be split.

**Notice:** Be sure to follow figures two and three when making your own cables. Do not use the ground lug on the XLR connector. Do not connect the cable's shield conductor to the ground lug or allow the shield conductor to come in contact with the XLR's outer casing. Grounding the shield could cause a short circuit and erratic behavior.

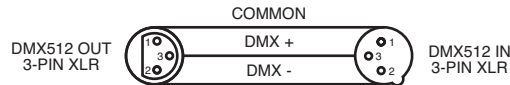

Figure 2

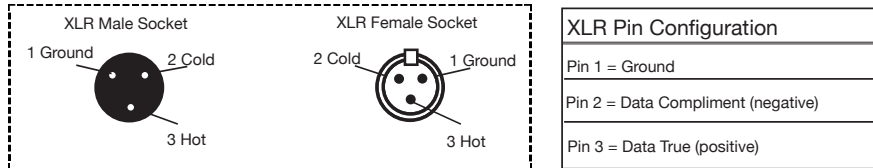

Figure 3

**Special Note: Line Termination.** When longer runs of cable are used, you may need to use a terminator on the last unit to avoid erratic behavior. A terminator is a 110-120 ohm 1/4 watt resistor which is connected between pins 2 and 3 of a male XLR connector (DATA + and DATA -). This unit is inserted in the female XLR connector of the last unit in your daisy chain to terminate the line. Using a cable terminator (ADJ part number Z-DMX/T) will decrease the possibilities of erratic behavior.



Termination reduces signal errors and avoids signal transmission problems and interference. It is always advisable to connect a DMX terminal, (Resistance 120 Ohm 1/4 W) between PIN 2 (DMX-) and PIN 3 (DMX +) of the last fixture.

Figure 4

**5-Pin XLR DMX Connectors.** Some manufactures use 5-pin DMX-512 data cables for DATA transmission in place of 3-pin. 5-pin DMX fixtures may be implemented in a 3-pin DMX line. When inserting standard 5-pin data cables in to a 3-pin line a cable adaptor must be used, these adaptors are readily available at most electric stores. The chart below details a proper cable conversion.

3-Pin XLR to 5-Pin XLR Conversion		
Conductor	3-Pin XLR Female (Out)	5-Pin XLR Male (In)
Ground/Shield	Pin 1	Pin 1
Data Compliment (- signal)	Pin 2	Pin 2
Data True (+ signal)	Pin 3	Pin 3
Not Used		Pin 4 - Do Not Use
Not Used		Pin 5 - Do Not Use

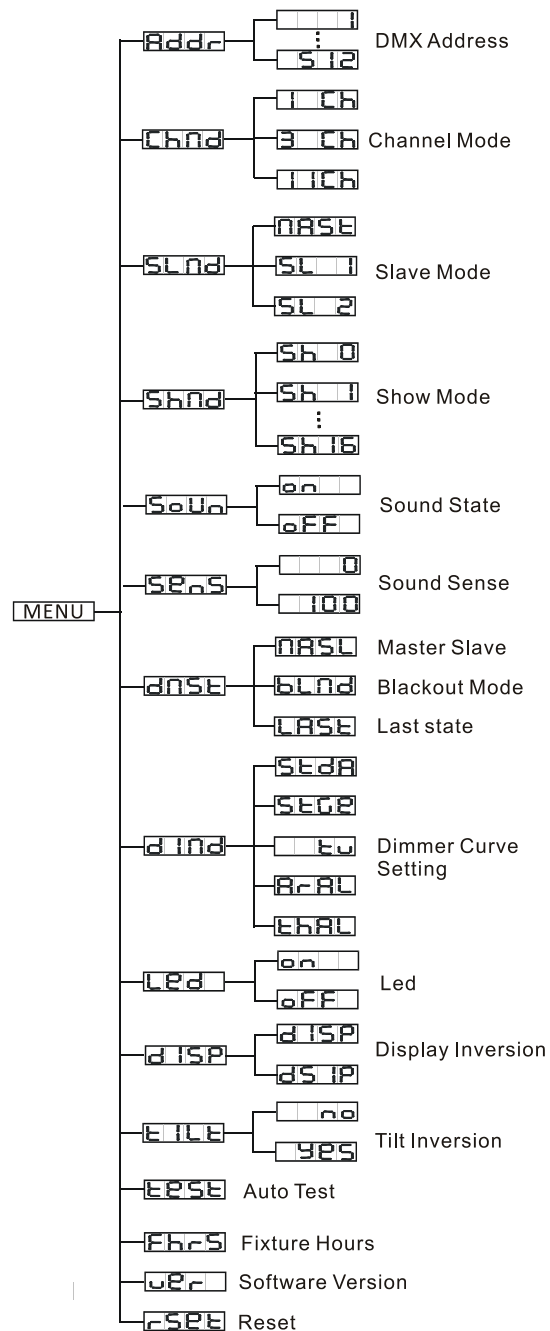

**System Menu:** When making adjustments press **ENTER** to confirm your setup then press and hold the **MENU** button for at least 3 seconds. To exit without making any adjustments press the **MENU** button. The display will lock after 30 seconds, press the **MENU** button for 3 seconds to unlock.

## ADDR - DMX Address Setting.

1. Press the MENU button until “**ADDR**” is displayed, press ENTER.
2. The current address will now be displayed and flashing. Press the UP or DOWN buttons to find your desired address. When you have found your desired DMX address press ENTER then press and hold the MENU button for at least 3 seconds to set your desired DMX address.
3. Connect your DMX Controller.

## CHND - This will let select your desired DMX channel mode.

1. Press the MENU button until “**CHND**” is displayed, press ENTER. Either “**1CH**”, “**3CH**”, or “**11CH**” will be displayed
2. Press the UP or DOWN buttons to find your desired DMX channel mode and press ENTER to confirm and exit.

## SLND - This will let you set unit as a slave in a master-slave configuration.

1. Press the MENU button until “**SLND**” is displayed, press ENTER. Either “**MAST**”, “**SL 1**” or “**SL 2**” will be displayed.
2. Press the UP or DOWN buttons until your desired setting is displayed, and press ENTER to confirm.

**NOTE:** In a Master/Slave configuration you can set one fixture to Master and then set the next fixture to “**SL 2**”, the fixtures

will now have contrast movement to each other.

### **SHND: SH 0 - SH16 - Show modes 0-16 (Factory programs). Show mode can run with or without sound active mode active.**

1. Press the MENU button until “**SHND**” is displayed, press ENTER.
2. “**Sh X**” will now be displayed, “X” representing a number between 0-16. Programs 1-16 are factory programs, while “Sh 0” is random mode. Press the UP or DOWN buttons to find your desired show.
3. When you have found your desired show press ENTER, then press and hold the MENU button for at least 3 seconds to activate. After you have set your desired show, it can be changed at any time using the UP or DOWN buttons.

### **SOUN - Sound Active mode.**

1. Press the MENU button until “**SOUN**” is displayed, press ENTER.
2. The display will show either “**ON**” or “**OFF**”. Press the UP or DOWN buttons to select “**ON**” to activate sound active mode, or “**OFF**” to deactivate sound active mode.
3. Press ENTER, then press and hold the MENU button for at least 3 seconds to activate.

### **SENS - In this mode you can adjust the sound sensitivity.**

1. Press the MENU button until “**SENS**” is displayed, press ENTER.
2. A number between 0-100 will be displayed. Press the UP or DOWN buttons to adjust the sound sensitivity. 0 being the least

sensitive, and 100 being the most sensitive.

3. When you have found your desired setting press ENTER to confirm.

### **DNST - This mode can be used as a precaution mode, that in case the DMX signal is lost, interrupted, or power is lost, the operating mode chosen in the setup is the running mode the fixture will go into when the DMX signal is lost. You can also set this as the operating mode you would like the unit to return to when power is applied.**

1. Press the MENU button until “**DNST**” is displayed, and either “**MASL**”, “**BLND**”, or “**LAST**” will be displayed beneath.
2. Press ENTER and the bottom choice will begin to flash. Use the UP or DOWN buttons to choose an operating mode you would like the unit to start up in when power is applied or the DMX signal is lost.
  - **MASL** (Master-Slave) - If the DMX signal is lost or power is applied, the unit will automatically go into Master Slave mode and run a built-in show.
  - **BLND** (Blackout) - If the DMX signal is lost or interrupted, the unit will automatically go into stand by mode.
  - **LAST** - If the DMX signal is lost or interrupted the fixture will stay in the last DMX setting. If power is applied and this mode is set, the unit will automatically go into the last DMX set up.
3. Press ENTER to confirm your desired set up.

### **DIND - In this mode you can select the dimmer curve.**

1. Press the MENU button until “**DIND**” is displayed, press ENTER.
2. The current dimmer curve setting will be displayed.

3. Press the UP or DOWN buttons to find your desired dimmer curve and press ENTER to confirm. See the Dimmer Curve Chart on page 21 for more information.

### **LED - With this function you can have the LED display backlight turn off after 10 seconds.**

1. Press the MENU button until “**LED**” is displayed, press ENTER.
2. The display will show either “**ON**” or “**OFF**”. Press the UP or DOWN buttons to select “**ON**” to keep the LED display on at all times, or “**OFF**” to switch to have the LED display switch off after 10 seconds.
3. Press ENTER to confirm. To make the LED display reappear after it has turned off, press any button.

### **DISP - This function will reverse the display 180°.**

1. Press the either the MENU button until “**DISP**” is displayed, press ENTER.
2. Press the UP button to select “**DSIP**” to “flip” the display, or “**DISP**” to change the display back.
3. Press ENTER to confirm.

### **TILT - Tilt Inversion**

1. Press the MENU button until “**TILT**” is displayed, press ENTER. Either “**YES**” or “**YES**” will be displayed.
2. To activate the Tilt inversion press the UP or DOWN buttons until YES is displayed, press ENTER to confirm. To deactivate Tilt inversion, select NO and press Enter.

### **TEST - This function will run a self test program. The test program will test pan/tilt movement and colors.**

1. Press the MENU button until “**TEST**” is displayed, press ENTER.
2. The fixture will now run a self test. Press MENU to exit.

### **FHRS - With this function you can display the running time of the unit.**

1. Press the MENU button until “**FHRS**” is displayed, press ENTER.
2. The running time of the fixture will now be displayed. Press MENU to exit.

### **VER - With this function you can display the software version of the unit.**

1. Press the MENU button until “**VER**” is displayed, press ENTER.
2. The software version will now be displayed. Press MENU to exit

### **RSET - Use this function to reset the unit.**

1. Press the MENU button until “**RSET**” is displayed, press ENTER.
2. The fixture will now reset.

**Operating Modes:** The Zipper can operate in three different modes. In each mode you can run the fixture as a stand alone fixture or in a master/slave configuration. This next section will detail the differences in the operating modes.

• **Sound Active mode -**

The fixture will react to sound, chasing through the built-in programs.

• **Show mode -**

The fixture will run one of 16 shows.

• **DMX control mode -**

This function will allow you to control each individual fixtures traits with a standard DMX-512 controller.

**Universal DMX Control:** This function allows you to use a Elation® universal DMX-512 controller to control the chases and patterns, dimmer and strobe. A DMX controller allows you to create unique programs tailored to your individual needs.

1. The Zipper has 3 DMX Modes. See pages 17-20 for detailed description of the DMX modes, values, and traits.
2. To control your fixture in DMX mode, follow the set-up procedures on pages 5-7 as well as the set-up specifications that are included with your DMX controller.
3. Use your DMX controller's faders to control the various DMX fixture traits.
4. Follow the instructions on page 9 to set your DMX channel mode and the DMX address.
5. For longer cable runs (more than a 100 feet) use a terminator on the last fixture.
6. For help operating in DMX mode consult the manual included with your DMX controller.

**Sound Active Mode:** This mode allows either a single unit or several units linked together, to run to the beat of the music.

1. Press the MENU button until "**SOUN**" is displayed, and press ENTER. Press the UP or DOWN buttons so that "**ON**" is displayed and press ENTER.
2. To adjust the sound sensitivity level press the MENU button until "**SENS**" is displayed, and press ENTER. Use the UP or DOWN buttons to adjust the sensitivity level, "0" being least sensitive,

"100" being the most sensitive. Press ENTER to set your level.

**Show Mode:** This mode allows either a single unit or several units linked together, to run one of 16 shows that you choose. Show mode can run with or without sound active mode.

1. Press the MENU button until "**SHND**" is displayed, and press ENTER.
2. Press the UP or DOWN buttons until you find your desired show, press ENTER, then press and hold the MENU button for at least 3 seconds to activate. After you have set your desired show, it can be changed at any time using the UP or DOWN buttons.

**Master-Slave Configuration** This function will allow you to link up to 16 units together and operate without a controller. The units will be sound activated. In Master-Slave operation one unit will act as the controlling unit and the others will react to the controlling units programs. Any unit can act as a Master or as a Slave.

1. Using approved DMX data cables, daisy chain your units together via the XLR connector on the rear of the units. Remember the Male XLR connector is the input and the Female XLR connector is the output. The first unit in the chain (master) will use the female XLR connector only - The last unit in the chain will use the male XLR connector only. For longer cable runs we suggest a terminator at the last fixture.
2. On the Master unit press the MENU button until "**SLND**" is displayed, and press ENTER. Use the UP and DOWN buttons to scroll to the "**MAST**" setting and press ENTER.
3. After setting the Master unit to the master setting find your desired operating mode.
4. On the slave units press the MENU button until "**SLND**" is displayed, and press ENTER. Choose either "**SL 1**" or "**SL 2**" and press ENTER. See page 10 for more info.
5. The slave units will now follow the Master unit.



**Zipper****UC IR Remote Control**

The **UC IR** infrared remote gives you control of various functions (See below). To control the fixture you must aim the remote at the front of the fixture and be no more than 30 feet away.

**STAND BY** - Pressing this button will blackout the fixture.

**FULL ON** - Pressing the button will put the output at full intensity. When the button is released the output will return to the normal state.

**FADE/GOBO** - Invalid for this fixture.

**“DIMMER +” and “DIMMER -”** - Invalid for this fixture.

**STROBE** - This button will activate the strobe effect. If you press and hold this button the unit will begin to strobe.

**COLOR** - Invalid for this fixture.

**SOUND ON & OFF** - These buttons activate and deactivate the sound active mode.

**SHOW 0** - Press this button to activate the show mode. Use buttons 1-9 to select your desired show. To access shows 11-16, press the SHOW 0 button again, and use buttons 1-6 to select shows 11-16.

**Zipper****1 Channel Mode - DMX Traits & Values**

Channel	Value	Function
1		SHOWS
	0 - 7	BLACKOUT
	8 - 22	SHOW 1
	23 - 37	SHOW 2
	38 - 52	SHOW 3
	53 - 67	SHOW 4
	68 - 82	SHOW 5
	83 - 97	SHOW 6
	98 - 112	SHOW 7
	113 - 127	SHOW 8
	128 - 142	SHOW 9
	143 - 157	SHOW 10
	158 - 172	SHOW 11
	173 - 187	SHOW 12
	188 - 202	SHOW 13
	203 - 217	SHOW 14
	218 - 232	SHOW 15
233 - 247	SHOW 16	
248 - 255	SOUND ACTIVE SHOWS 1-16	

<b>Zipper 3 Channel Mode - DMX Traits &amp; Values</b>		
<b>Channel</b>	<b>Value</b>	<b>Function</b>
1	0 - 7	PAN/TILT MOVEMENTS 0 DEGREES
	8 - 22	MOVEMENT 1
	23 - 37	MOVEMENT 2
	38 - 52	MOVEMENT 3
	53 - 67	MOVEMENT 4
	68 - 82	MOVEMENT 5
	83 - 97	MOVEMENT 6
	98 - 112	MOVEMENT 7
	113 - 127	MOVEMENT 8
	128 - 142	MOVEMENT 9
	143 - 157	MOVEMENT 10
	158 - 172	MOVEMENT 11
	173 - 187	MOVEMENT 12
	188 - 202	MOVEMENT 13
	203 - 217	MOVEMENT 14
	218 - 232	MOVEMENT 15
	233 - 247	MOVEMENT 16
248 - 255	SOUND ACTIVE MOVEMENT 1-16	
2	0 - 255	DIMMER 0% - 100%
3	0 - 7	STROBING OFF
	8 - 15	OPEN
	16 - 131	STROBING SLOW - FAST
	132 - 139	OPEN
	140 - 181	PULSE EFFECT SLOW - FAST FAST CLOSE - SLOW OPEN
	182 - 189	OPEN
	190 - 231	PULSE EFFECT SLOW - FAST SLOW CLOSE - FAST OPEN
	232 - 239	OPEN
	240 - 247	SOUND ACTIVE STROBING
	248 - 255	OPEN

<b>Zipper 11 Channel Mode - DMX Traits &amp; Values</b>		
<b>Channel</b>	<b>Value</b>	<b>Function</b>
1	0	BARREL 1 STOP
	1 - 127	CLOCKWISE ROTATION SLOW - FAST
	128 - 255	COUNTER-CLOCKWISE ROTATION FAST - SLOW
2	0	BARREL 2 STOP
	1 - 127	CLOCKWISE ROTATION SLOW - FAST
	128 - 255	COUNTER-CLOCKWISE ROTATION FAST - SLOW
3	0	BARREL 3 STOP
	1 - 127	CLOCKWISE ROTATION SLOW - FAST
	128 - 255	COUNTER-CLOCKWISE ROTATION FAST - SLOW
4	0	BARREL 4 STOP
	1 - 127	CLOCKWISE ROTATION SLOW - FAST
	128 - 255	COUNTER-CLOCKWISE ROTATION FAST - SLOW
5	0 - 255	RED LED 0% - 100%
6	0 - 255	GREEN LED 0% - 100%
7	0 - 255	BLUE LED 0% - 100%
8	0 - 255	WHITE LED 0% - 100%
9	0 - 255	MASTER DIMMER 0% - 100%
10	0 - 7	STROBE
	8 - 15	BLACKOUT
	16 - 131	OPEN
	132 - 139	STROBING SLOW - FAST
	140 - 181	OPEN
	182 - 189	SLOW OPEN - FAST CLOSE OPEN

## Zipper 11 Channel Mode - DMX Traits & Values

Channel	Value	Function
10	190 - 231	STROBE
	232 - 239	FAST OPEN - SLOW CLOSE
	240 - 247	OPEN
	248 - 255	SOUND ACTIVE STROBE
11	0 - 20	OPEN
	21 - 40	DIMMER MODE
	41 - 60	STANDARD
	61 - 80	STAGE
	81 - 100	TV
	101 - 255	ARCHITECTURAL THEATRE DEFAULT DIMMER SETTING

## Zipper Power Cord Daisy Chain

With this feature you can connect the fixtures to one another using the IEC input and output sockets. The quantity that can be connected is 10 fixtures maximum for 120V and 18 fixtures maximum for 240V. After the maximum fixtures has been reached you will need to use a new power outlet. They must be the same fixtures. DO NOT mix fixtures.

## Zipper Photometric Chart

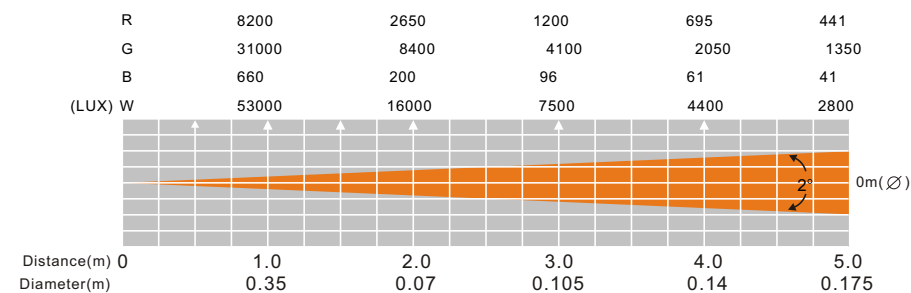

## Zipper Dimmer Curve Chart

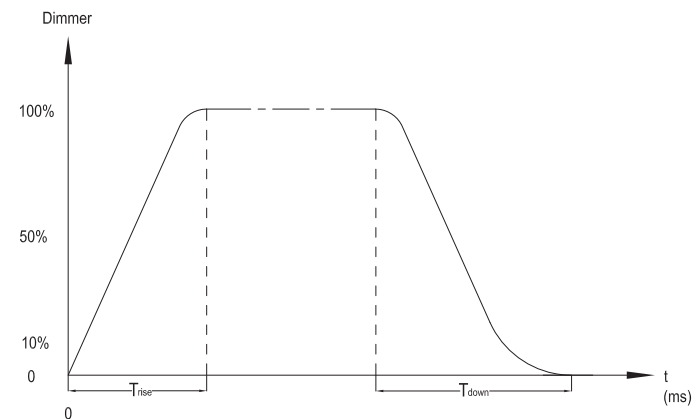

Ramp Effect	0 $\rightarrow$ 255 OS (Fade Time)		0 $\rightarrow$ 255 1S (Fade Time)	
	$T_{rise}$ (ms)	$T_{down}$ (ms)	$T_{rise}$ (ms)	$T_{down}$ (ms)
Standard	0	0	0	0
Stage	780	1100	1540	1660
TV	1180	1520	1860	1940
Architectural	1380	1730	2040	2120
Theatre	1580	1940	2230	2280

## Zipper

## Fuse Replacement

Locate the fuse holder is located at the rear of unit next to the power cord. Using a phillips head screwdriver, remove the fuse holder. Remove the used fuse and replace with a matching fuse. Insert the fuse holder and fuse into the unit and secure the fuse holder.

## Zipper

## Cleaning

**Fixture Cleaning:** Due to fog residue, smoke, and dust cleaning the internal and external optical lenses and mirror should be carried out periodically to optimize light output. Cleaning frequency depends on the environment in which the fixture operates (i.e. smoke, fog residue, dust, dew). In heavy club use we recommend cleaning on a monthly basis. Periodic cleaning will ensure longevity, and crisp output.

1. Use normal glass cleaner and a soft cloth to wipe down the outside casing.
2. Use a brush to wipe down the cooling vents and fan grill.
3. Clean the external optics with glass cleaner and a soft cloth every 20 days.
4. Clean the internal optics with glass cleaner and a soft cloth every 30-60 days.
5. Always be sure to dry all parts completely before plugging the unit back in.

## Zipper

## Trouble Shooting

**Trouble Shooting:** Listed below are a few common problems that you may encounter, with solutions.

### ***No light output from the unit;***

1. Be sure the external fuse has not blown. The fuse is located on the bottom panel of the unit.
2. Be sure the fuse holder is completely and properly seated.

### ***Unit does not respond to sound;***

1. Low frequencies (bass) should cause the unit to react to sound. Tapping on the microphone, quiet or high pitched sounds may not activate the unit.

## Zipper

## Warranty

### MANUFACTURER'S LIMITED WARRANTY

- A. ADJ Products, LLC hereby warrants, to the original purchaser, ADJ Products, LLC products to be free of manufacturing defects in material and workmanship for a prescribed period from the date of purchase (see specific warranty period on reverse). This warranty shall be valid only if the product is purchased within the United States of America, including possessions and territories. It is the owner's responsibility to establish the date and place of purchase by acceptable evidence, at the time service is sought.
- B. **For warranty service you must obtain a Return Authorization number (RA#) before sending back the product—please contact ADJ Products, LLC Service Department at 800-322-6337.** Send the product only to the ADJ Products, LLC factory. All shipping charges must be pre-paid. If the requested repairs or service (including parts replacement) are within the terms of this warranty, ADJ Products, LLC will pay return shipping charges only to a designated point within the United States. If the entire instrument is sent, it must be shipped in its original package. No accessories should be shipped with the product. If any accessories are shipped with the product, ADJ Products, LLC shall have no liability whatsoever for loss of or damage to any such accessories, nor for the safe return thereof.
- C. This warranty is void if the serial number has been altered or removed; if the product is modified in any manner which ADJ Products, LLC concludes, after inspection, affects the reliability of the product; if the product has been repaired or serviced by anyone other than the ADJ Products, LLC factory unless prior written authorization was issued to purchaser by ADJ Products, LLC; if the product is damaged because not properly maintained as set forth in the instruction manual.
- D. This is not a service contract, and this warranty does not include maintenance, cleaning or periodic check up. During the period specified above, ADJ Products, LLC will replace defective parts at its expense with new or refurbished parts, and will absorb all expenses for warranty service and repair labor by reason of defects in material or workmanship. The sole responsibility of ADJ Products, LLC under this warranty shall be limited to the repair of the product, or replacement thereof, including parts, at the sole discretion of ADJ Products, LLC. All products covered by this warranty were manufactured after August 15, 2012, and bear indentifying marks to that effect.
- E. ADJ Products, LLC reserves the right to make changes in design and/or improvements upon its products without any obligation to include these changes in any products theretofore manufactured.

No warranty, whether expressed or implied, is given or made with respect to any accessory supplied with products described above. Except to the extent prohibited by applicable law, all implied warranties made by ADJ Products, LLC in connection with this product, including warranties of merchantability or fitness, are limited in duration to the warranty period set forth above. And no warranties, whether expressed or implied, including warranties of merchantability or fitness, shall apply to this product after said period has expired. The consumer's and/or Dealer's sole remedy shall be such repair or replacement as is expressly provided above; and under no circumstances shall ADJ Products, LLC be liable for any loss or damage, direct or consequential, arising out of the use of, or inability to use, this product.

This warranty is the only written warranty applicable to ADJ Products, LLC Products and supersedes all prior warranties and written descriptions of warranty terms and conditions heretofore published. This warranty was revised after December 1, 2012.

### MANUFACTURER'S LIMITED WARRANTY PERIODS:

- **Lighting Products = 1-year (365 days) Limited Warranty** (Such as: Special Effect Lighting, Intelligent Lighting, UV lighting, Strobes, Fog Machines, Bubble Machines, Mirror Balls, Par Cans, Trussing, Lighting Stands etc. excluding LEDs and lamps)
- **Laser Products = 90-Day Limited Warranty**
- **L.E.D. Products = 2-year (730 days) Limited Warranty** (excluding motors, PCB boards, and power supplies, which have a 1-year (365 day Limited Warranty) and batteries which have a 180 day limited warranty).



Zipper	Specifications
<b>Model:</b>	<b>Zipper</b>
<b>Voltage:</b>	100V ~ 240V/50~60Hz
<b>LED:</b>	4 x 8W LEDs (1 Red, 1 Green, 1 Blue, & 1 White)
<b>Power Consumption:</b>	66W
<b>Power Cord Daisy Chain:</b>	10 Fixtures Max. (120V) 18 Fixtures Max. (230V)
<b>Dimensions:</b>	18.75”(L) x 9.75”(W) x 5.25”(H) 479 x 247 x 132mm
<b>Weight:</b>	13 Lbs. / 6 kgs.
<b>Beam Angle:</b>	128 Degrees
<b>Fuse:</b>	7 Amp
<b>Duty Cycle:</b>	None
<b>DMX:</b>	3 DMX Modes: 1 Channel Mode, 3 Channel Mode, & 11 Channel Mode
<b>Sound Active:</b>	Yes
<b>Working Position:</b>	Any Safe, Secure Position
<b>Warranty:</b>	2 Year (730 days)

**Auto Sensing Voltage:** This fixture contains a automatic voltage switch, which will auto sense the voltage when it is plugged into the power source.

**Please Note:** Specifications and improvements in the design of this unit and this manual are subject to change without any prior written notice.

ADJ Products, LLC  
6122 S. Eastern Ave. Los Angeles, CA 90040 USA  
Tel: 323-582-2650 / Fax: 323-725-6100  
Web: [www.adj.com](http://www.adj.com) / E-mail: [info@americandj.com](mailto:info@americandj.com)

A.D.J. Supply Europe B.V.  
Junostraat 2  
6468 EW Kerkrade  
Netherlands

Follow Us On:



[facebook.com/americandj](https://facebook.com/americandj)  
[twitter.com/americandj](https://twitter.com/americandj)  
[youtube.com/adjlighting](https://youtube.com/adjlighting)

[service@adjgroup.eu](mailto:service@adjgroup.eu) / [www.adj.eu](http://www.adj.eu)  
Tel: +31 45 546 85 00 / Fax: +31 45 546 85 99