

USER MANUAL FOR CCC CONTAINERIZED COMMAND CENTER EWCC EXPANDABLE WALL COMMAND CENTER User and General Purpose Maintenance Manual

FPU® SERIES

CONTAINERIZED COMMAND CENTER (TAN)
CONTAINERIZED COMMAND CENTER (GREEN)

PART NUMBER

CCC208-T
CCC208-G

NSN

8145-01-502-3930
8145-01-502-3930

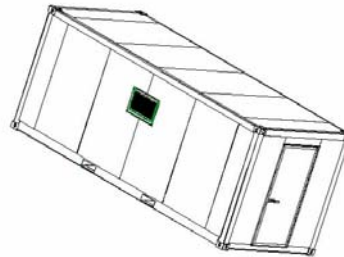
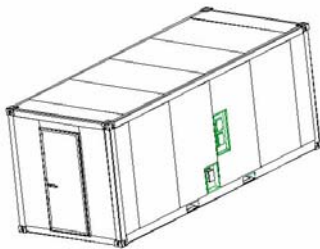

FPU® SERIES

EXPANDABLE WALL COMMAND CENTER (TAN)
EXPANDABLE WALL COMMAND CENTER (GREEN)

PART NUMBER

EWCC208-T
EWCC208-G

NSN

8145-01-502-3927
8145-01-502-3927

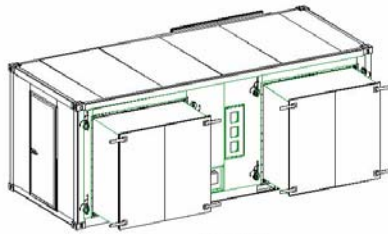

SCALE 0.020

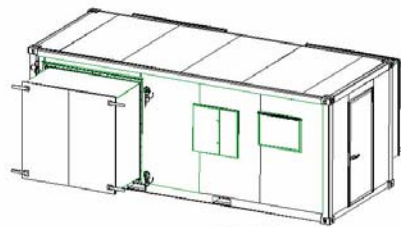

SCALE 0.020

THIS PAGE INTENTIONALLY LEFT BLANK

Figure 1.1-1
BOH EWCC Data Plates Location

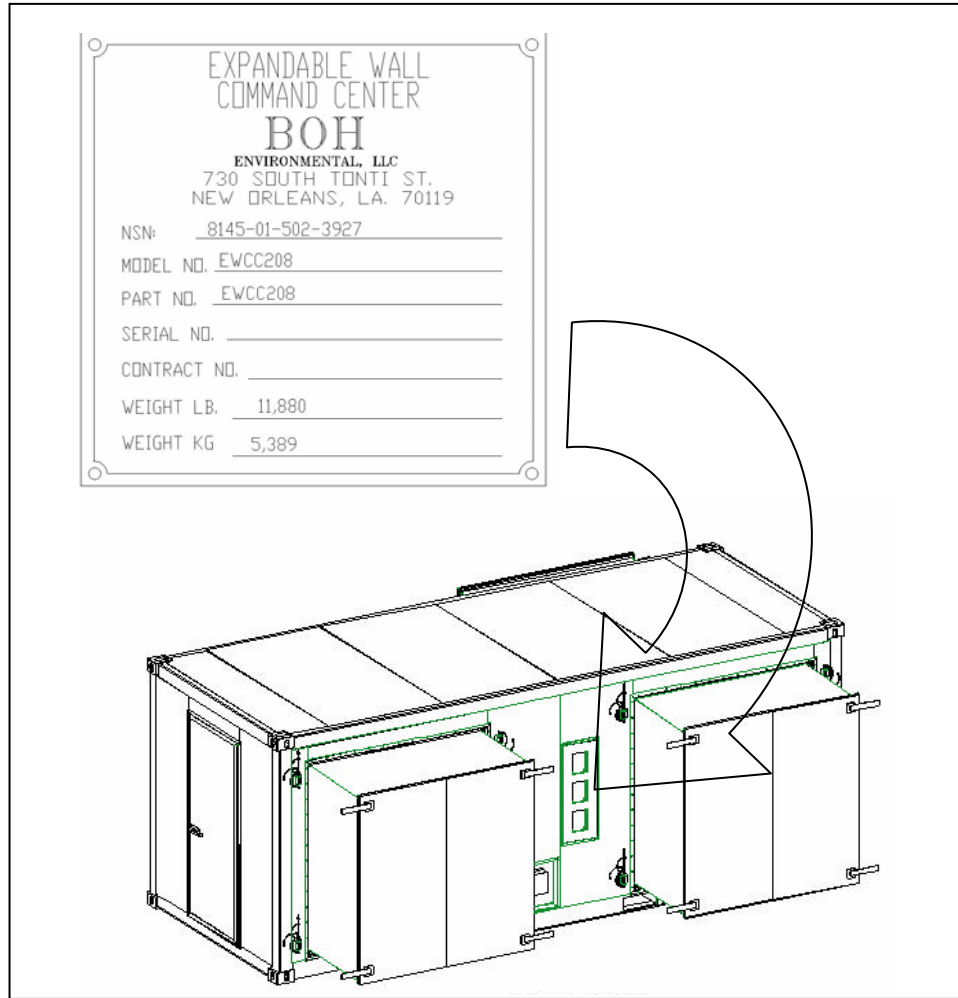

Figure 1.1-2
BOH CCC Data Plates Location

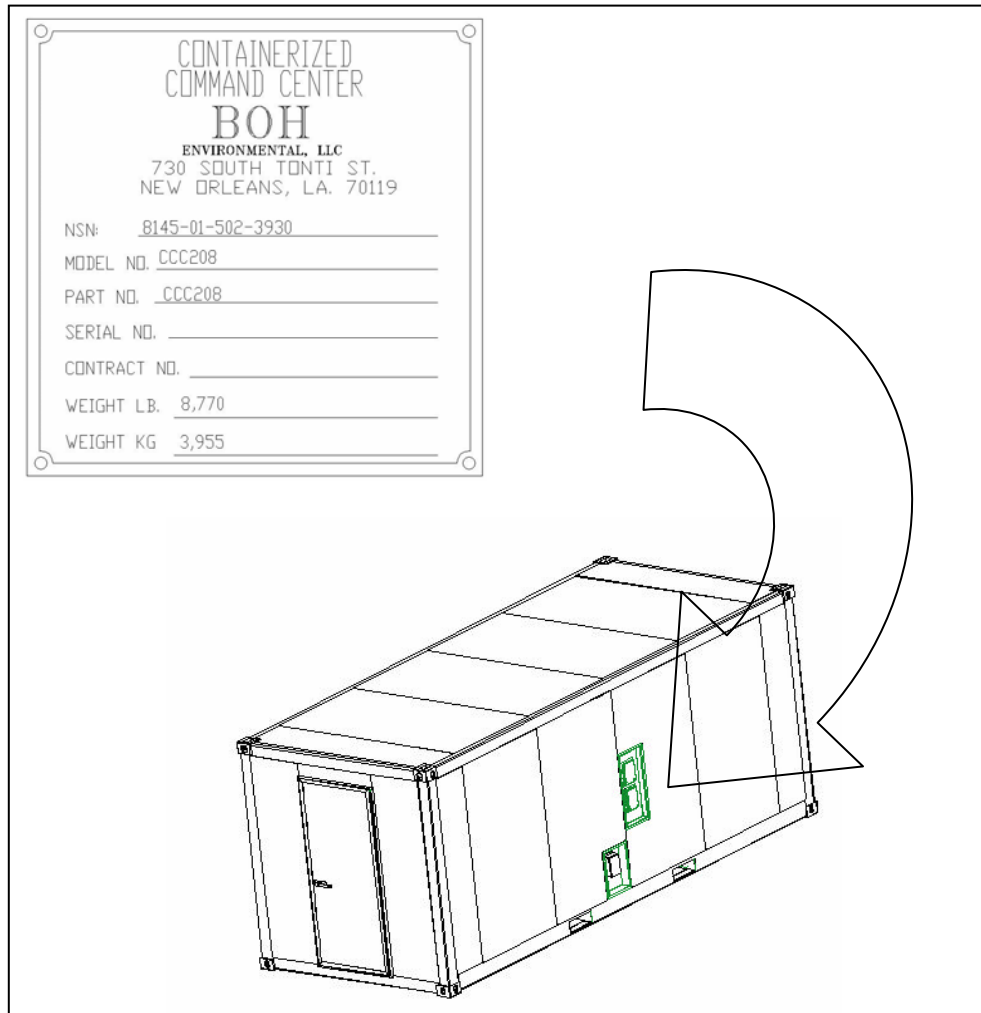

TABLE OF CONTENTS

Section.....	Page	Section.....	Page
DATA PLATES.....	i	V. EWCC EXPANDABLE WORK-STATIONS	
TABLE OF CONTENTS.....	iii	5.1 Expandable Work-Stations.....	18
LIST OF ILLUSTRATIONS.....	iv	5.2 EWCC Work-Station Preparation for Shipment.....	19
LIST OF TABLES.....	iv	VI. CCC and EWCC MAINTENANCE GUIDE	
SAFETY SUMMARY.....	v	6.1 Cleaning, Lubrication and Preventative Maintenance Checks and Services (PMCS).....	20
WARNING SUMMARY.....	vii	6.2 Lubrication.....	20
I. INTRODUCTION AND GENERAL INFORMATION		6.3 PMCS.....	21
1.1 Introduction.....	1	6.4 Repairs.....	21
1.2 General Information.....	1	6.5 Technical and Replacement Part Web Information Sources.....	22
1.3 Special Tools & Test Equipment.....	2	6.6 Troubleshooting.....	22
II. CCC and EWCC COMPONENTS AND ACCESSORIES		VII. CCC and EWCC ELECTRICAL COMMUNICATION DIAGRAMS	
2.1 CCC Components & Accessories.....	3	7.1 EWCC Electrical and Communication Diagrams.....	23
2.2 EWCC Components & Accessories.....	5	VIII. CCC and EWCC PARTS LISTS	
III. CCC and EWCC PREPARATION FOR USE, STORAGE, MOVEMENT AND SHIPMENT		8.1 Replacement Parts List.....	30
3.1 Preparation for Use.....	7	IX. WARRANTY	31
3.2 Preparation for Storage, Shipment, and Movement.....	8		
IV. CCC and EWCC SETUP AND OPERATIONS			
4.1 CCC and EWCC Operation.....	9		
4.2 Loading and Unloading.....	9		
4.3 CCC and EWCC Doors.....	10		
4.4 EWCC Doors and Floor Plan.....	13		
4.5 Red and White Light Conditions.....	13		
4.6 CCC and EWCC HVAC.....	14		
4.7 CCC and EWCC HVAC Latches.....	15		
4.8 CCC and EWC Computer Monitor Mounts.....	16		
4.9 Exterior Electrical Connections.....	17		

LIST OF ILLUSTRATIONS

Figure..... Page	Figure..... Page
Figure 1.1-1 BOH EWCC Data Plates Location.. i	Figure 4.6-1 HVAC..... 15
Figure 1.1-2 BOH CCC Data Plates Location.... ii	Figure 4.7-1 HVAC Latches..... 16
Figure 2.1-1 CCC Accessories Locations 4	Figure 4.8-1 CCC and EWCC Monitor Mounts 17
Figure 2.2-1 EWCC Accessories Locations..... 6	Figure 5.1-1 EWCC Workstation Setup..... 18
Figure 3.1-1 EWCC and CC Grounding Rod..... 7	Figure 5.1-2 Pins and Ratchet Straps..... 18
Figure 4.1-1 CCC Interior and EWCC Interior ... 9	Figure 5.2-1 Retracting Workstations 19
Figure 4.2-1 ISO Corner Block..... 9	Figure 7.1-1 EWCC Top Layout 23
Figure 4.2-2 Forklift Pockets 10	Figure 7.1-2 AC Side Layout 24
Figure 4.3-1 Door Damper and Door Light Switch 10	Figure 7.1-3 EWCC Load Center Layout..... 25
Figure 4.3-2 CCC Floor Plan..... 11	Figure 7.1-4 EWCC End Layout 26
Figure 4.3-3 Locks and Seals 12	Figure 7.1-5 CCC Load Center Layout..... 27
Figure 4.3-4 Interior Door Locks 12	Figure 7.1-6 CCC and EWCC Power Phase Hook-Up 28
Figure 4.4-1 Retracted EWCC Workstation Floor Plan 13	Figure 7.1-7 EWCC & CCC Communications Layout..... 29
Figure 4.5-1 Lighting Switch Locations 14	

LIST OF TABLES

Table..... Page	Table Page
Table 6.1-1 Cleaning Procedures 20	Table 6.5-1 Technical and Replacement Part Information Sources 22
Table 6.2-1 Lubrication 21	Table 6.6-1 Troubleshooting Checks..... 22
Table 6.3-1 Preventative Maintenance Checks and Services (PMCS) 21	Table 8.1-1 Replacement Parts List 30

SAFETY SUMMARY

This warning summary contains general safety precautions and hazardous material warnings that must be understood and applied during operation and maintenance of this equipment. Failure to observe these warnings could result in serious injury or death.

GENERAL WARNINGS



HEAVY PARTS - heavy object on human figure shows that heavy parts present a danger to life or limb.



HEAVY PARTS - heavy object pinning human figure against wall shows that heavy, moving parts present a danger to life or limb.



HEAVY PARTS - hand with heavy object on top shows that heavy parts can crush and harm.



HEAVY PARTS - foot with heavy object on top shows that heavy parts can crush and harm.



SLICK FLOOR - wavy line on floor with legs prone shows that slick floor presents a danger for slipping or falling.



HEAVY OBJECT - human figure stooping over heavy object shows physical injury potential from improper lifting technique.



ELECTRICAL - electrical wire to arm with electricity symbol running through human body shows that shock hazard is present.



ELECTRICAL - electrical wire to hand with electricity symbol running through hand shows that shock hazard is present.



CRYOGENIC - hand in block of ice shows that the material is extremely cold and can injure human skin or tissue.



FIRE - flame shows that a material may ignite and cause burns.



VAPOR - human figure in a cloud shows that material vapors present a danger to life or health.



CHEMICAL - drops of liquid on hand shows that the material will cause burns or irritation to human skin or tissue.



EYE PROTECTION - person with goggles shows that the material will injure the eyes.

WARNING SUMMARY

This warning summary contains general safety warnings and hazardous material warnings that must be understood and applied during operation and maintenance of this equipment. Failure to observe these precautions could result in serious injury or death to persons using equipment.

WARNING



Do not allow the system to swing if using an overhead lift. Always insure an appropriate sling is used in the lift. Always use properly sized forklift, crane, or lifting device. Failure to comply could cause injury to personnel or damage to the equipment.

WARNING



Standard forklift principles apply when working with or on the CCC & EWCC. When working with ground guides during the loading or unloading of a module, never move the CCC & EWCC onto the transport vehicle while the ground guide is between the forks, transport vehicle, and the CCC container. Serious injury could occur if the ground guide is pinned between the forklift and the CCC container. Forklift operators must maintain visual contact with their ground guides at all time.

Always follow standard forklift procedures. A tilt hazard exists when forklift operators try to lift a CCC & EWCC container with the forks not completely inserted. Always lift a CCC & EWCC container with the forks completely seated and the fork frame against the CCC & EWCC container. This places the heavier part of the load back into the tines versus out on the tips. A tilt situation exists when the heaviest part of the load is out on the tips of the tines, on uneven ground, with forks fully extended, and while traveling. Operators should always keep loads low and close to the forklift carriage. Operators should never travel when the load is in the fork's extended position.

WARNING



The CCC contents are heavy and could cause injury if they fall onto or strike personnel. As a rule, always insure that equipment, i.e. monitors, computers, printers etc. are secured with the straps provided. The CCC workstations are heavy, but roll easily; seek assistance when deploying the workstation to operating position. Never store or transport equipment that is not part of the function or mission of the CCC & EWCC.

WARNING



Fall hazards exist when climbing onto or working from the top of the container. Always maintain three points of contact when climbing onto the CCC & EWCC container. Never move, step, or walk backwards when working on top of the system. All movement should be in the forward direction. A fall can occur if personnel lose concentration and step backwards off of the edge. Stand erect only if necessary and only away from the edge. Working from a kneeling position helps reduce the threat of a fall.

The CCC & EWCC interior floor and rooftop will encounter mud, snow, ice, rainwater, and other potentially slippery substances. Keeping the inside floor of the containers clean is important; nevertheless, when these conditions exist always move with caution inside CCC & EWCC containers. Failure to maintain cleanliness could cause a slip and injury.

WARNING



The EWCC equipment can be heavy and awkward to handle by a single person. This is especially true of the larger components, i.e. rollout workstations. The movement and adjustment of these items is a two-person operation.

WARNING



Overhead power lines and obstructions can cause serious injury or damage to property. Forklift operators, truck drivers, and ground guides should always clear overhead when loading, unloading, or moving the CCC & EWCC containers.

WARNING



To prevent electrical shock hazard, only trained and qualified personnel should attempt to correct electrical discrepancies. Additionally, electrical power must be disconnected before any electrical system work is performed.

WARNING



Protective gloves should be worn when handling metal parts in below freezing temperatures. Failure to wear gloves may result in skin freezing to the metal upon contact and cause tearing of the flesh when attempting to pull away from the metal.

WARNING



Dry cleaning solvent is flammable and cannot be used near an open flame. Use only in well-ventilated places and have a fire extinguisher available. Use of protective clothing as directed in the product MSDS is required. Failure to comply could result in injury to personnel or equipment damage. Do not allow cleaning solvents or compounds to come in contact with door seals, covers, fabric, or rubber components. Damage to these components will occur.

SECTION I
INTRODUCTION AND GENERAL INFORMATION

THIS PAGE INTENTIONALLY LEFT BLANK

SECTION I INTRODUCTION AND GENERAL INFORMATION

1.1 INTRODUCTION

- 1.1.1 Purpose.** This User Manual provides operational, safety and maintenance information for the Containerized Command Center (CCC) and the Expandable Wall Command Center (EWCC).
- 1.1.2 Manual Scope.** This manual will cover safety, minor repair, suggested service and maintenance, troubleshooting, and provides a parts list with illustrations to help the operating personnel use the system to its full capacity.

1.2 GENERAL INFORMATION

- 1.2.1 Descriptions.** BOH Environmental's Containerized Command Center is a durable ISO configured, 20-foot long single container that is a portable command and control center. The CCC has four workstations with communication via phone and Intranet/Internet connection. The BOH Environmental Expandable Wall Command Center is also a durable ISO configured, 20 foot long single container with communication via phone and Intranet/Internet connection. The EWCC is a portable command and control center that provides six expandable workstations.
- 1.2.2 CCC and EWCC System Benefits.** The CCC and EWCC are air-conditioned/heated single rooms that provide file cabinets, shelves with straps for printers, scanners, and retractable monitor base mounts for securing computer monitors during transit. The CCC and EWCC provide the operators with a rapid set-up or takedown capability for the quick deployment and relocation of the command center. The CCC and EWCC have 110v60Hz, single phase power, retractable air-conditioner/heater (HVAC), and two 2-stage doors with automatic trip-switch for low-voltage white/red light.
- 1.2.3 CCC and EWCC Manufacturer's Data Plate.** The CCC and EWCC data plates identify the manufacturer's part number, serialization, contract and delivery order number and National Stock Number (NSN). The CCC data plates are unique by serial number to each container. Further information with regard to the BOH line of products can be found on the BOH web site.

www.bohenvironmental.com

Additionally, BOH can be reached at:

BOH Environmental, LLC
FPU Mobility Systems Division
4116C Walney Road, Chantilly, VA 20151
Ph: (703) 449-6020 Fax: (703) 449-6022

1.3 SPECIAL TOOLS AND TEST EQUIPMENT

1.3.1 **Descriptions.** A General Mechanics Tool Set (NSN 5180-01-454-3787) is sufficient to perform minor repairs on the containers and modules.

Note: All hardware is standard thread and removed with a Counterclockwise rotation and tightened with a Clockwise rotation.

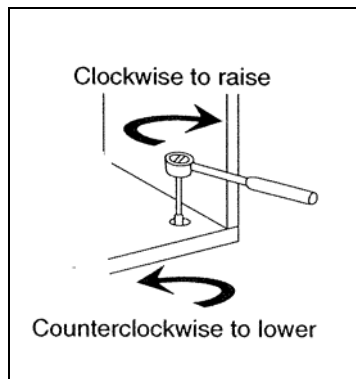

WARNING



Personnel performing electrical repairs and service should be certified electricians and have the proper tools and test equipment.

SECTION II
CCC and EWCC COMPONENTS AND ACCESSORIES

THIS PAGE INTENTIONALLY LEFT BLANK

SECTION II
CCC and EWCC Components and Accessories

This section 2.1 describes the following components:

FPU® SERIES	PART NUMBER	NSN
CONTAINERIZED COMMAND CENTER (TAN)	CCC208-T	8145-01-502-3930
CONTAINERIZED COMMAND CENTER (GREEN)	CCC208-G	8145-01-502-3930

2.1 CCC COMPONENTS & ACCESSORIES

- 2.1.1 Description.** The system consists of the BOH Environmental Containerized Command Center (CCC) that has four workstations for communication via phone and Intranet/Internet connection.
- 2.1.2** The CCC is provided with two entry doors and four desk workstations with a continuous top (1). Each workstation has two lockable file cabinets with four drawers (2). **See Figure 2.1-1.**
- 2.1.3** The CCC has a centrally located retractable heater/air-conditioner (HVAC) (3), wall mounted file cabinets (4) with latch type doors, wall mounted shelves for securing equipment, i.e. printers, scanners, etc. and overhead white and red condition lights (5). **See Figure 2.1-1.**
- 2.1.4** Each CCC work station is provided with a wall mounted surge protected power strip (6), an adjustable roller chair (7) and retractable computer monitor base mount (8) that are easily retracted below the desktop with straps to secure the monitor while in transit. **See Figure 2.1-1.**

Figure 2.1-1
CCC Accessories Locations

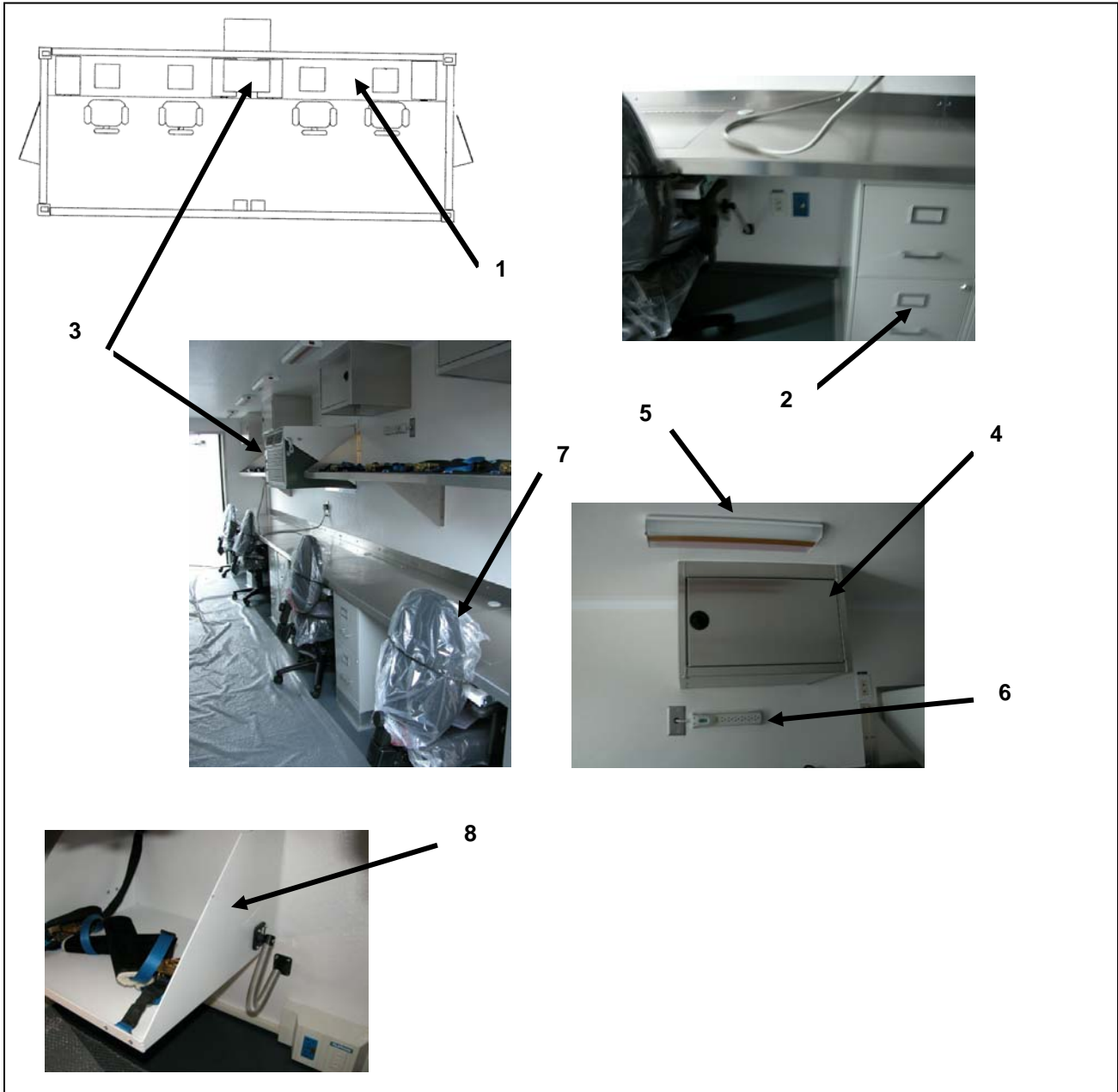

This section 2.2 describes the following components:

FPU® SERIES	PART NUMBER	NSN
EXPANDABLE WALL COMMAND CENTER (TAN)	EWCC208-T	8145-01-502-3927
EXPANDABLE WALL COMMAND CENTER (GREEN)	EWCC208-G	8145-01-502-3927

2.2 EWCC COMPONENTS & ACCESSORIES

- 2.2.1 Description.** The system consists of the BOH Environmental Expandable Wall Command Center (EWCC) — a durable ISO configured, 20' x 8' single container that is a command and control center. The EWCC has 6 workstations for communication via phone and Intranet/Internet connection.
- 2.2.2** The EWCC is provided with a main door (1), a secondary entry door (2), and three roll out workstation platforms (3) to provide six retractable desk workstations (4) **See Figure 2.2-1.**
- 2.2.3** The EWCC has a retractable heater/air-conditioner (HVAC) (5), overhead wall mounted file cabinets (6) with latch type doors, wall mounted shelves for securing equipment, i.e. printers, scanners, etc. and overhead white and red condition lights (7). **See Figure 2.2-1.**
- 2.2.4** Each EWCC work station is provided a wall mounted surge protected outlet GFCI, an adjustable chair (8) fixed to the floor and computer monitor base mounts (9) that are easily retracted below the desktop with straps to secure the monitor while in transit and storage. **See Figure 2.2-1.**

Figure 2.2-1
EWCC Accessories Locations

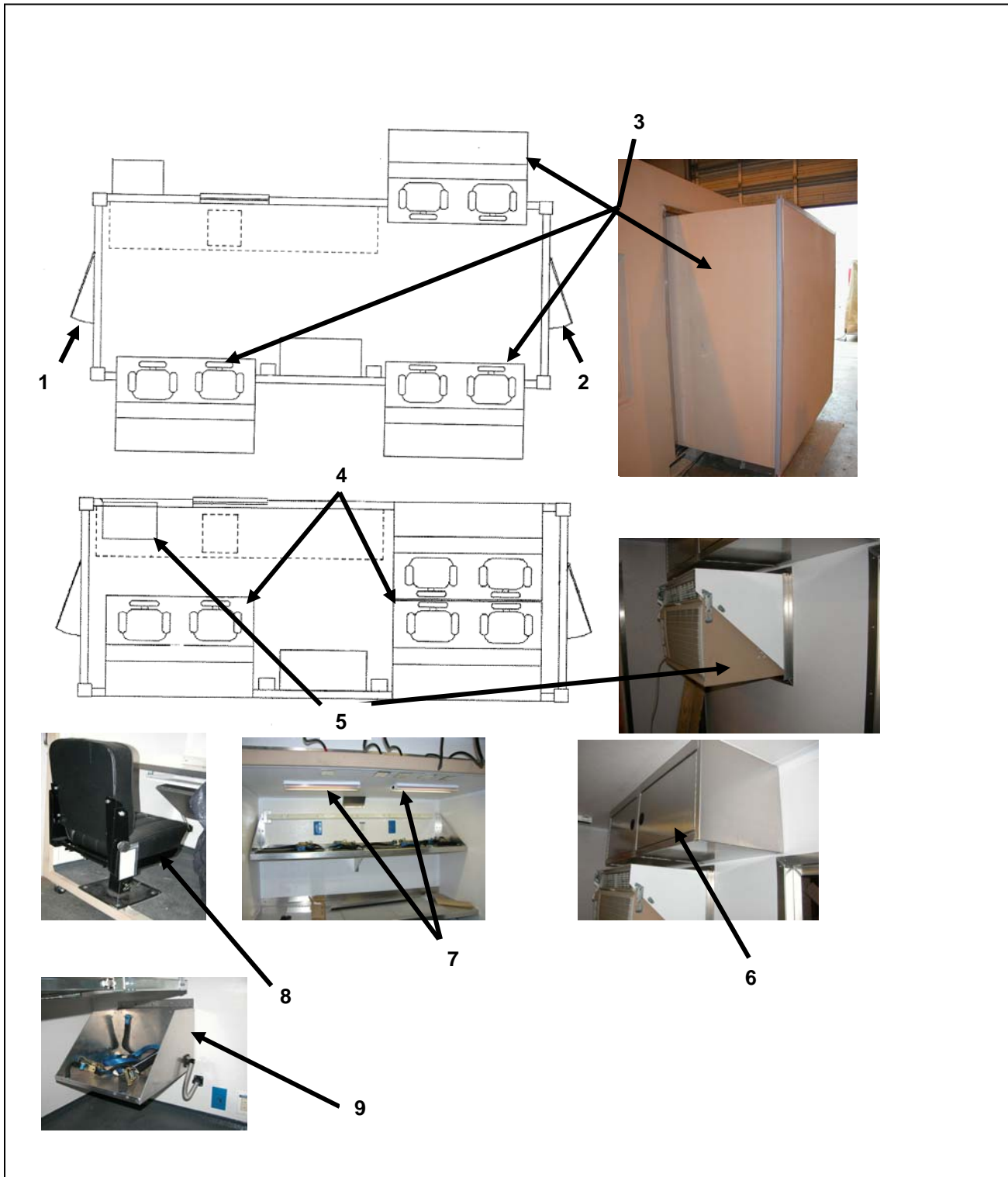

**SECTION III
CCC and EWCC
PREPARATION FOR USE, STORAGE, MOVEMENT AND SHIPMENT**

THIS PAGE INTENTIONALLY LEFT BLANK

**Section III
CCC and EWCC
Preparation for Use, Storage, Movement, and Shipment**

NOTE: Review the Safety Summary prior to any MHE Movement, Service or Operation of the CCC and EWCC on Pages iv through vii.

NOTE: Consult the Container manufacturer's Data Plate for Maximum Gross Weight for each type of container.

3.1 PREPARATION FOR USE

3.1.1 Site Requirements. Relatively level terrain, soil and weather conditions such as mud, ice, snow, sand and flood plane should be considered when selecting a site for the containers to insure safety of operating personnel.

WARNING



Electrical Considerations. The supporting electrical extension cords or generator should be grounded properly with Grounding Rod assembly (1) mounted on the interior wall near the communication panels prior to making electrical connection to the CCC and EWCC. See Electrical Diagrams in Section VII. See Figure 3.1-1.

**Figure 3.1-1
EWCC and CCC Grounding Rod**

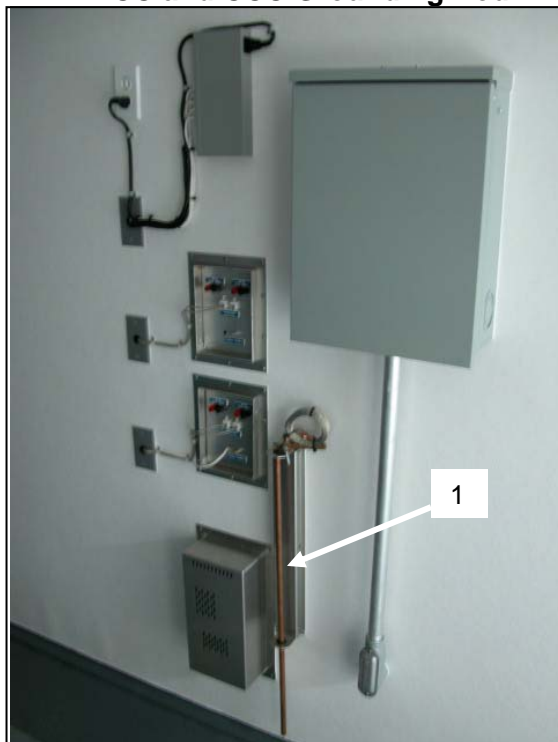

3.2 PREPARATION FOR STORAGE, SHIPMENT AND MOVEMENT

WARNING



A ground guide should always be in view when moving or positioning the CCC and EWCC.

- 3.2.1 The retractable workstations for the EWCC and all other equipment, i.e. HVAC for both the CCC and EWCC should be fully retracted and properly secured prior to storage, shipment or movement.
- 3.2.2 In preparation for storage, shipment or movement, standard practice is that all loose material should be removed and general cleaning and inspection of the interior should be performed.
- 3.2.3 All locking devices, shelves, drawer latches and door edges should be swept or wiped clean of debris and inspected to insure they function prior to securing the CCC and EWCC.
See Cleaning Table 6.1-1.
- 3.2.4 Lubrication of all moving parts, devices, locks, latches, and hinges should be performed.

NOTE: Lubrication and cleaning of the CCC and EWCC moving parts is recommended prior to long-term storage or shipment. **See Cleaning and Lubrication Tables 6.1-1 and 6.2-1.**
- 3.2.5 All shelves, chairs, equipment, i.e. monitors, printers, and HVAC units should be locked in place and secured with straps, pins and locking devices that are provided, prior to closing the container.
- 3.2.6 **Do's and Don'ts for CCC and EWCC Transport.** When transporting the CCC and EWCC to another location via truck, flatbed, or FPU Transport System (FPU-TS), the CCC and EWCC should be properly secured to that transport platform to prevent stress damage to the CCC and EWCC during transportation.

CAUTION

Do not transport or store material that is not part of, or intended for, the CCC and EWCC function or mission.

**SECTION IV
CCC and EWCC SETUP AND OPERATIONS**

THIS PAGE INTENTIONALLY LEFT BLANK

SECTION IV CCC AND EWCC SETUP AND OPERATION

4.1 CCC AND EWCC OPERATION

Figure 4.1-1
CCC Interior and EWCC Interior

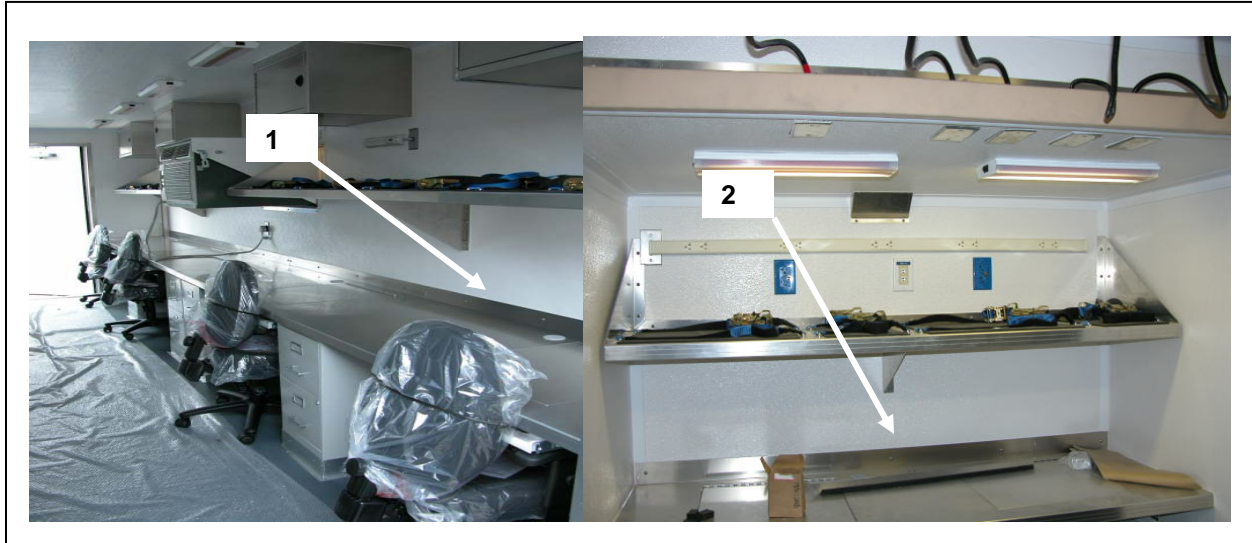

4.1.1 Description. The CCC is a four-workstation container (1) and the EWCC is a six workstation (2) that are stand-alone 20 ft. long FPU containers. **See Figure 4.1-1.**

4.1.2 Electrical Operation. The CCC and EWCC feature quick-disconnect 110v 60 Hz, single-phase power, a retractable HVAC, shelves for printers/CPU, pop-up monitor trays and 2 doors with automatic switch for low-voltage white/red light. **See CCC and EWCC Electrical Diagram in Section VII.**

4.2 Loading and Unloading

A Crane may be used in loading both the CCC and the EWCC containers onto various transport platforms by means of the top four ISO corner blocks (1). **See Figure 4.2-1.**

Figure 4.2-1
ISO Corner Block

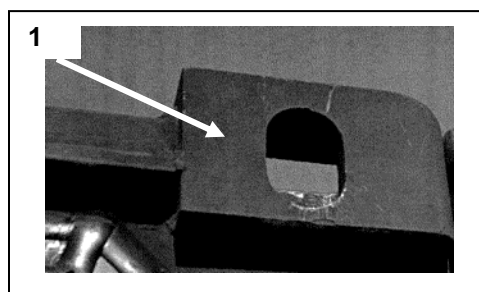

4.2.1 Site Requirements. Relatively level terrain, soil and weather conditions such as mud, ice, snow, sand and flood plane should be considered when selecting a site for the containers to adequately insure the safety of operating personnel.

4.2.2 CCC and EWCC Transport. The CCC and EWCC are forklift-capable with forklift pockets (1) on either side of the container. **See Figure 4.2-2.**

**Figure 4.2-2
Forklift Pockets**

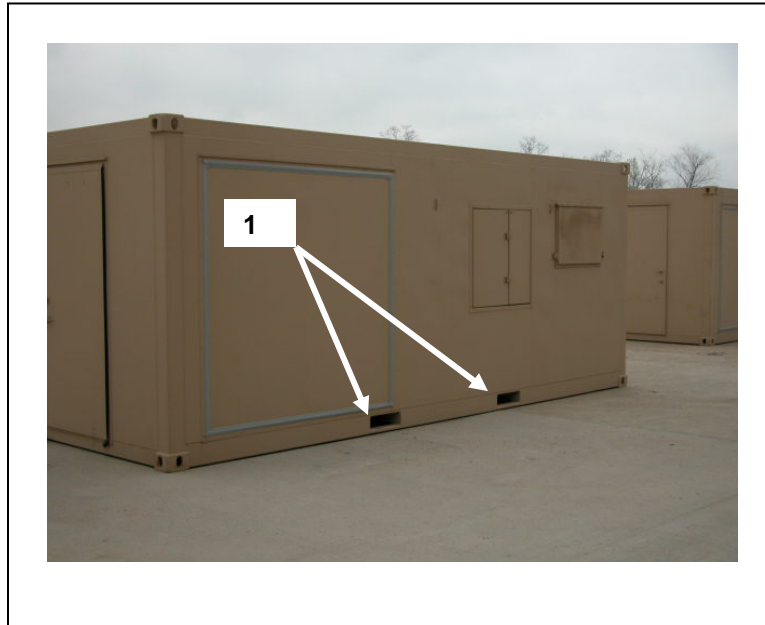

4.3 CCC and EWCC Doors

4.3.1 The CCC and EWCC both have two common entrance doors and are provided with door dampers (1) and interior light red/ white interrupter switches (2) for door operation. **See Figure 4.3-1.**

**Figure 4.3-1
Door Damper and Door Light Switch**



- 4.3.2 The CCC and EWCC have a main entrance door (1) and a secondary access door (2). The main entrance door is located (when facing the door) with the electrical and communication hookups (3) on the right side of the container and the retractable heater/air conditioner (HVAC) (4) on the center left side of the container. Light switches (5) are located on the interior right side of the main door (1). See Figure 4.3-2

Figure 4.3-2
CCC Floor Plan

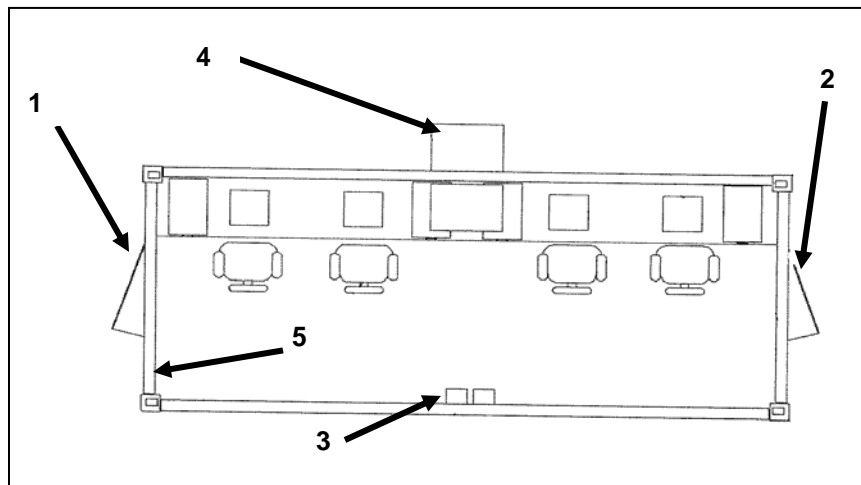

- 4.3.3 **Door locks** The CCC and EWCC have a robust lock system that consists of a large handle with a key (1) and piston (2). When engaged, the piston (2) provides a positive locked position (3) to secure the door handle. A door handle instruction plate (4) is provided on the door. See Figure 4.3-3.

- 4.3.4 The door handle operation is as follows:

1. To engage the interior door lock-blade (6), swing the exterior handle (5) downward then return it to the center position; at this point the door may be key locked. See Figure 4.3-3.
2. To open the door and disengage the interior lock-blade (6), swing the handle (5) to the upward OPEN position and return to center position. See Figure 4.3-3.

NOTE: Ensure the door is in the unlocked position before attempting to open or close.

Figure 4.3-3
Door lock

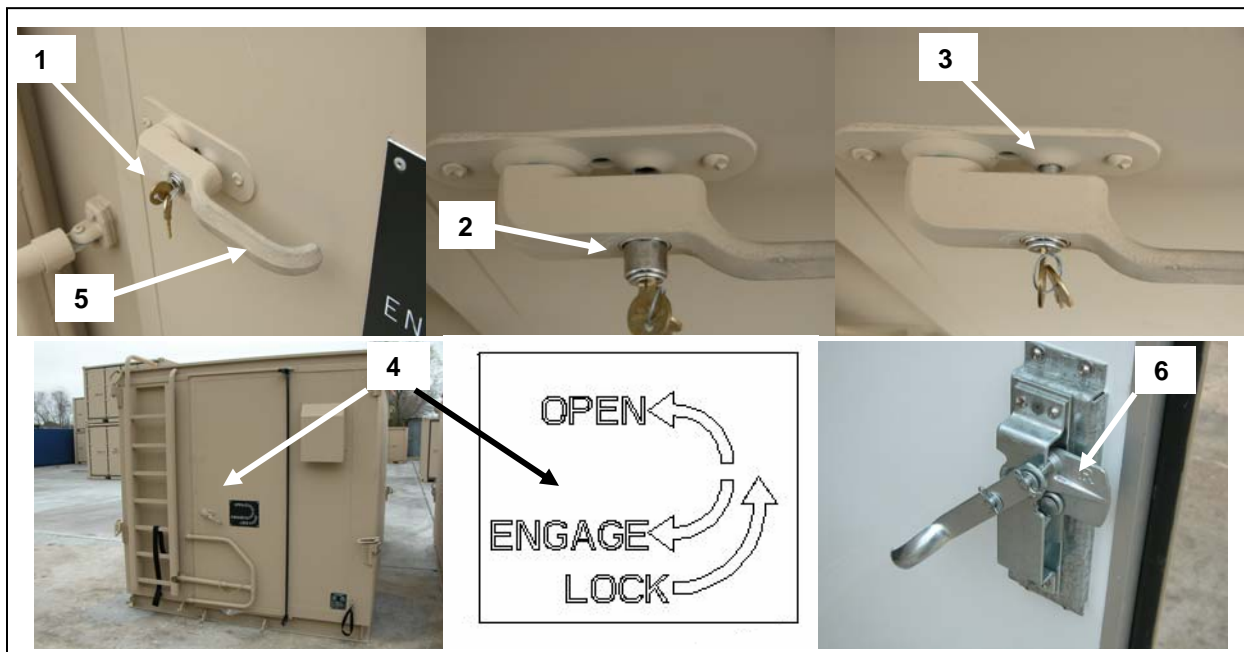

4.3.5 **Interior Door Lock.** The MWC door mechanism is design to allow exit while the exterior lock is engaged. Pull door handle (2) upward to open. See Figure 4.3-4.

FIGURE 4.3-4
Interior Door Lock

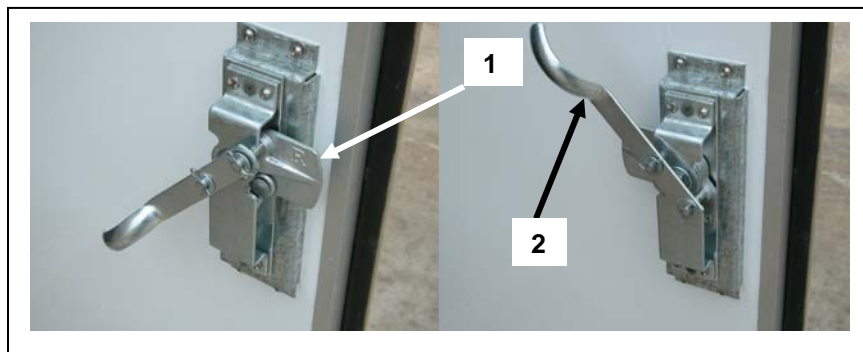

4.4 EWCC Doors and Floor Plan

- 4.4.1 The EWCC has a main entrance (1) and a secondary access door (2). The main entrance door is located (when facing the door) with the electrical hookups (3) on the right side of the container and the retractable heater/air conditioner (HVAC) (4) and window (5) on the left side of the container. Light switches (6) are located on the interior right side of the main door (1). See Figure 4.4-1.

Figure 4.4-1
Retracted EWCC Work-Station Floor Plan

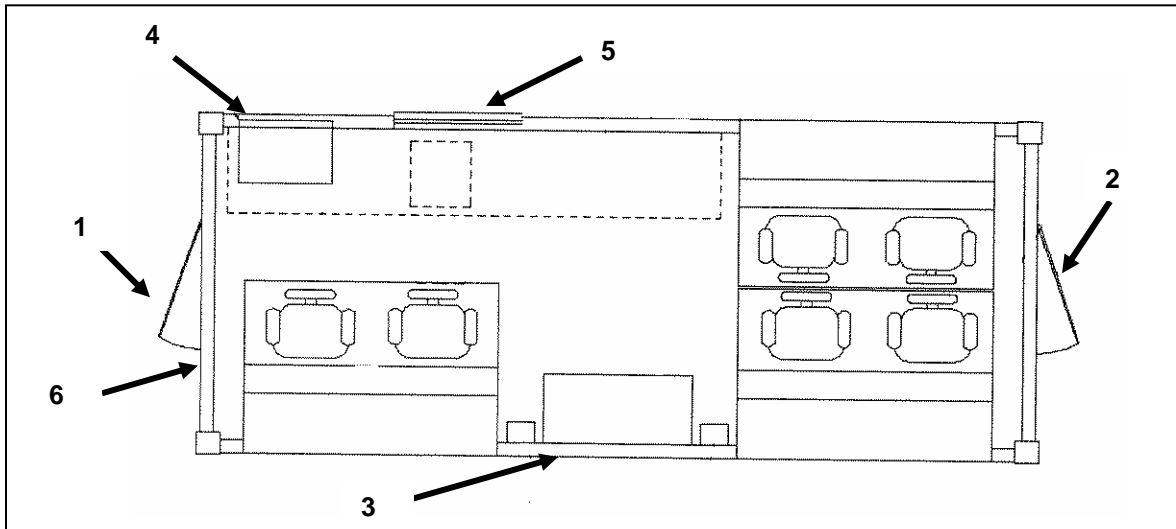

4.5 Red and White Lighting conditions

- 4.5.1 The EWCC and CCC are provided a bank of two switches, just inside the main entrance door. See Fig. 4.3-2 (5) and 4.4-1 (6).

4.5.2 They are used to set the red/white lighting conditions.

4.5.3 The left switch (1) sequence is as follows: See Fig. 4.5-1.

1. The left switch in the **Up-position** will select Door switch Activated. That enables the door switches to interrupt white light from escaping when the door is opened and switch to red light.
2. When in the **Center-position** the lighting is off.
3. When in the **Down-position** the light selection red is continuous.

4.5.4 The right switch (2) sequence is as follows: See Fig. 4.5-1.

1. The right switch is used to select white or red lighting.
2. In the **Up** position the white lighting is selected.
3. In the **Down** position the red lighting is selected.

NOTE: The door switches will not permit the white lights to stay on when the doors are opened in both the red or white condition.

Figure 4.5-1
Lighting Switch Locations

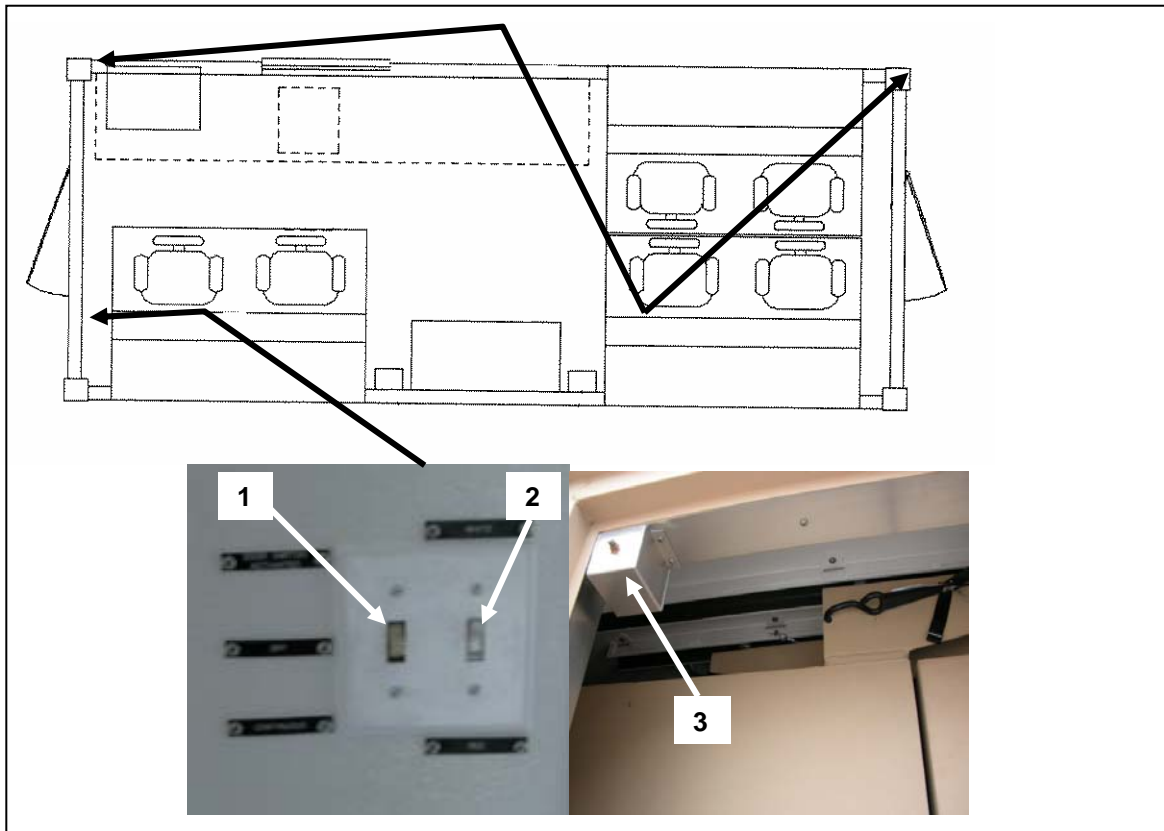

4.6 CCC and EWCC HVAC

- 4.6.1** The CCC and EWCC are provided with a Heater/Air-conditioner unit (HVAC) (4) located on the left side of the container. The HVAC is mounted on drawer slides for easy deployment to the operating position. **See Figure 4.4-1.**
- 4.6.2** The HVAC has a weather cover and exterior door (2) with latches to cover the unit during shipment or storage. This door must first be unlatched (3) to allow the HVAC to be unlocked and pushed out into the operating position. **See Figure 4.6-1.**

CAUTION

Do not attempt to operate the HVAC without opening the shutter door and pushing out the unit to the operating position. Overheating will result if the unit is operated in the stowed position.

- 4.6.3** The HVAC can be retracted within the CCC and EWCC with latch devices for securing during storage and shipment and unlatched to be pushed out for HVAC operation.

Figure 4.6-1
HVAC

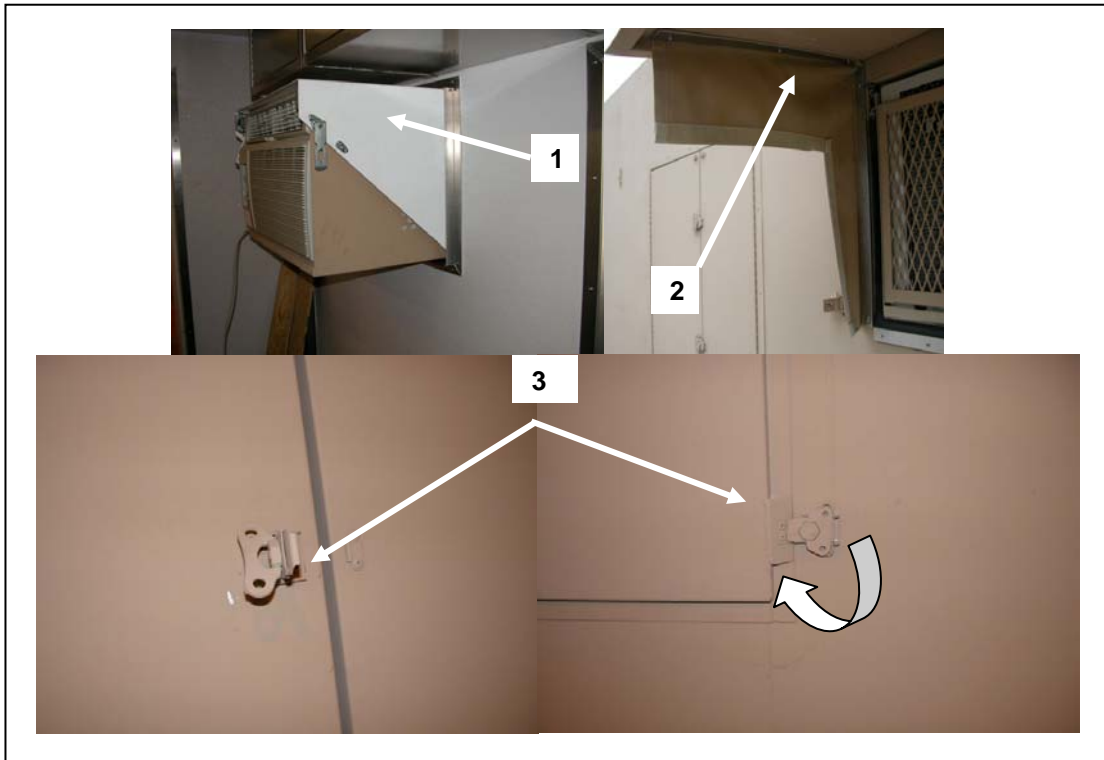

4.7 CCC and EWCC HVAC Latches

- 4.7.1 The locking devices for the HVAC are on the right and left side of the unit and must be unlatched to deploy the HVAC to the operating position. **See Fig. 4.7-1.**
- 4.7.2 The latches in the locked position (1) must be pulled out and rotated downward to the released position (2). At this point the HVAC can be pushed out to the operating position. **See Fig. 4.7-1.**
- 4.7.3 A lock bar (3) engages a bracket (4) on each side of the HVAC to securely lock the HVAC in place. **See Fig. 4.7-1.**

Figure 4.7-1
HVAC Latches

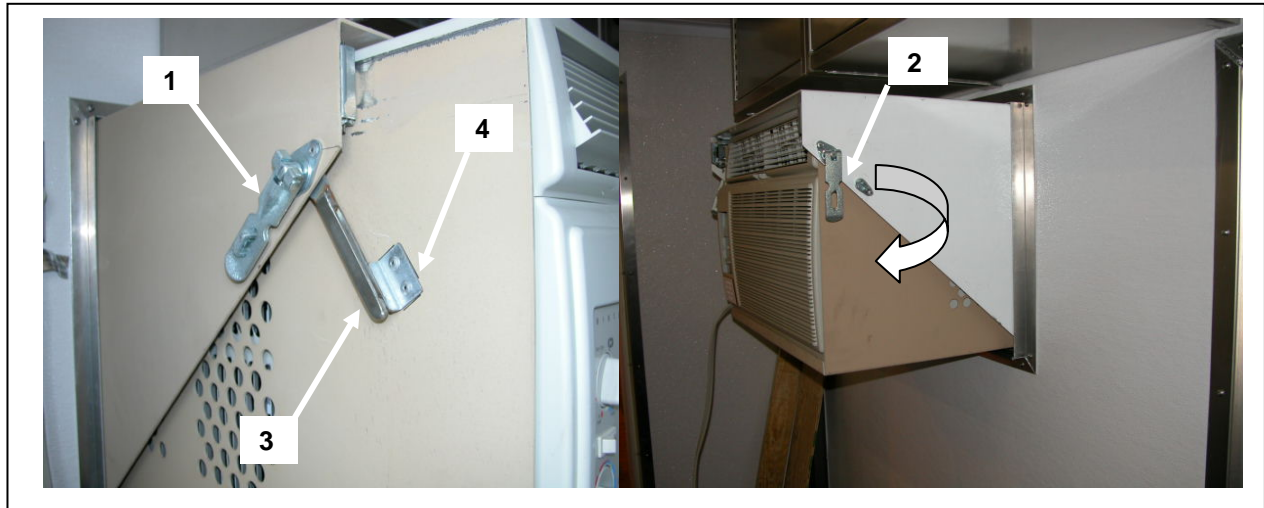

4.8 CCC and EWCC Computer Monitor Mounts

- 4.8.1 Each CCC and EWCC workstation desktop (1) is provided a retractable keyboard tray (2) and a retractable monitor-mounting tray (3) that holds the computer monitor with straps (4). This allows the monitor to be retracted below the desktop (1) during storage and shipment. **See Figure 4.8-1.**
- 4.8.2 The monitor-mounting tray (3) is supported by flexible springs (5) on either side of the monitor-mounting tray (3) that allows easy positioning of the monitor. **See Figure 4.8-1.**
- 4.8.3 The monitor-mounting tray (3), from the stowed position, is raised to the operating position by pushing forward on the springs (5). **See Figure 4.8-1.**
- 4.8.4 To lower the monitor, pull forward on the springs (5) to allow the monitor to retract below the desktop (1) for storage. **See Figure 4.8-1.**

Figure 4.8-1
CCC and EWCC Monitor Mounts

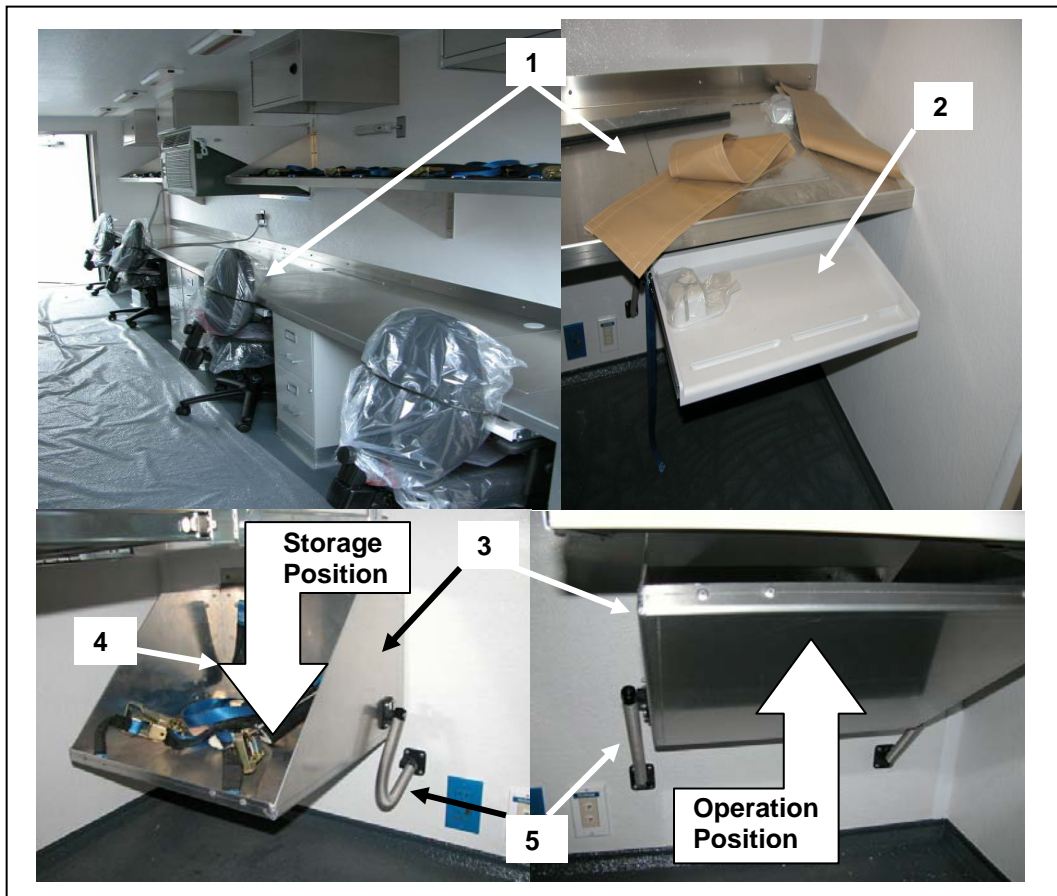

4.9 Exterior Electrical Connections

4.9.1 The EWCC/CCC is provided with an external cable (2) connection to an external generator for 240VAC supply. The EWCC/CCC is 110VAC, 60Hz, Single Phase. **See Figure 7.1-6.**

- 4.9.3.1 Connect wires as follows:
- Black wire - shore power line 1
 - Red wire - shore power line 2
 - White wire - shore power neutral
 - Green wire - shore power ground

NOTE: This is standard residential coloring. A generator should have outputs labeled as L1, L2, N, G or by color or both.

4.9.4 The cables are housed within a protective compartment on one side of the container marker "Shore Power Connection".

NOTE: The 240VAC wire ends are (bare wire) open ends with no connectors so the user may determine the type and style of connection required to a source such as a generator or 240VAC power source.

THIS PAGE INTENTIONALLY LEFT BLANK

**SECTION V
EWCC EXPANDABLE WORKSTATIONS**

THIS PAGE INTENTIONALLY LEFT BLANK

SECTION V
EWCC Expandable Workstations

5.1 Expandable Workstations

CAUTION

Insure the area outside the container is clear of obstructions prior to deploying the workstations.

5.1.1 The EWCC has three rollout workstations that expand the work area of the container.

Figure 5.1-1
EWCC Work-Station Setup

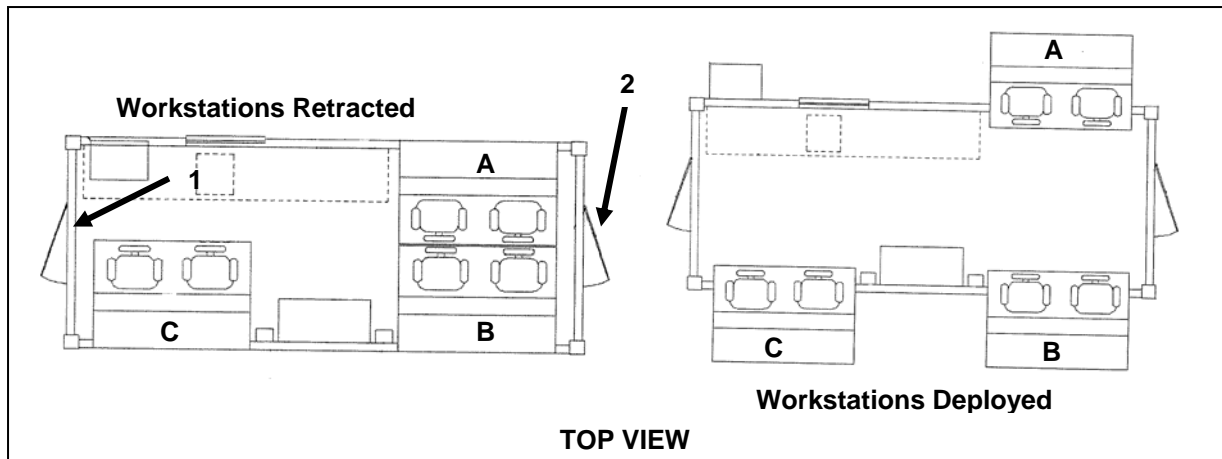

5.1.2 There are three workstations A, B and C in the EWCC that can be deployed with relative ease by releasing the securing pins (1) and ratchet straps (2). **See Fig. 5.1-1.**

5.1.3 The pins (1) and ratchet straps (2) must be accessed from both the main and secondary entrance doors. **See Fig. 5.1-2.**

Figure 5.1-2
Pins and Ratchet Straps

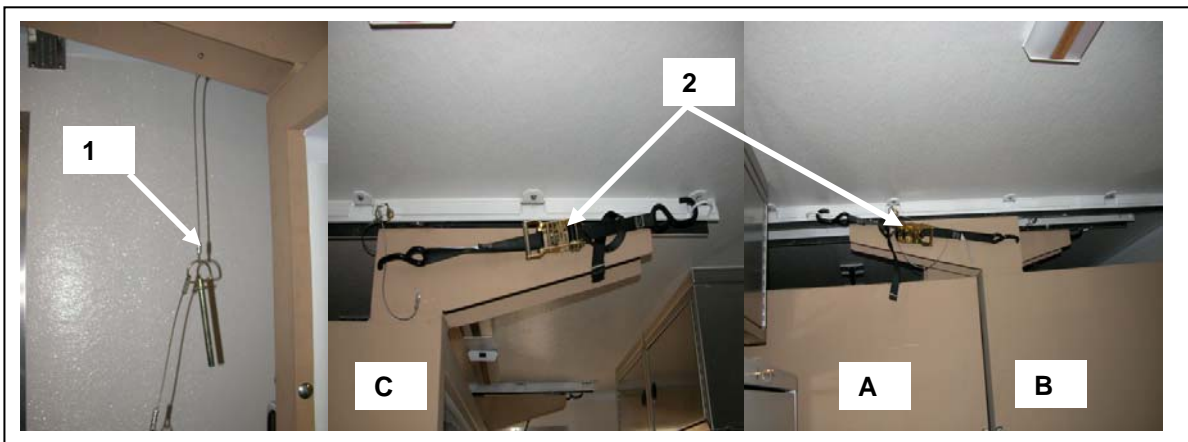

5.1.4 The sequence for deploying the workstations is as follows:

1. Remove the workstation retention pins located outside the container (3) and attached to each side of the workstation. **See Fig. 5.2-1.**
2. After electrical power, ground connection and lighting has been established, two personnel should enter the container, one from the main entrance door (1) and the other from the secondary entrance door (2). **See Fig. 5.1-1.**
3. At this point the ratchet straps (2) and pins (1) from both workstations may now be removed and workstations A and B may be deployed. **See Fig. 5.1-2.**
4. Secure the workstations A and B with pins (1) to prevent their movement. **See Fig. 5.1-2.**
5. Proceed to third workstation C next to the main entrance door and remove the pins (1) and ratchet straps (2) and deploy the workstation. **See Fig. 5.1-2.**
6. Secure the workstation C with pins (1) to prevent its movement. **See Fig. 5.1-2.**

5.2 EWCC WorkStation Preparation for Shipment

5.2.1 Retracting and securing sequence for the three workstations is as follows:

1. Remove the securing pins from workstation A with assistance from other personnel from the exterior of the container, push the workstation (1) until fully retracted and the hand holds (2) are together and outer seal (3) makes good contact. **See Fig. 5.2-1.**

**Figure 5.2-1
Retracting the Work-Stations**



2. Secure the workstation with the pins (1) and ratchet straps (2). **See Fig. 5.1-2.**
3. Remove the securing pins (3) from workstation B with assistance from other personnel from the exterior of the container, push the workstation until fully retracted and the outer seal makes good contact.
4. Secure the workstation with the pins (1) and ratchet straps (2). **See Figure 5.1-2.**
5. Proceed to third workstation C next to the main entrance door and remove the securing pins (1) with assistance from other personnel from the exterior of the container, push the workstation (1) until fully retracted and the outer seal (3) makes good contact.
6. Secure the workstation with the pins (1) and ratchet straps (2). **See Figure 5.1.2.** Re-attach Workstation retention pins located outside the container.

**SECTION VI
CCC AND EWCC MAINTENANCE GUIDE**

THIS PAGE INTENTIONALLY LEFT BLANK

**SECTION VI
CCC and EWCC MAINTENANCE GUIDE**

Review the Safety Summary on pages iv to vii prior to any MHE Movement, Service or Operation of the CCC & EWCC.

6.1 Cleaning, Lubrication and Preventative Maintenance Checks and Services (PMCS)

**WARNING
Chemical Hazard**

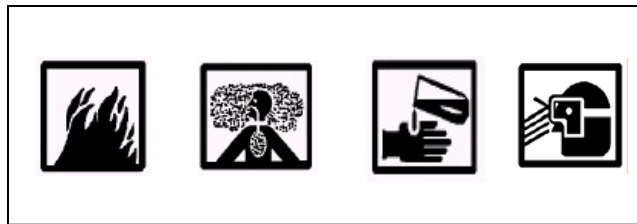

6.1.1 Cleaning. Cleaning is performed after an operational event and periodically if stored/ staged outside to insure the containers, modules and accessories will perform as designed. Cleaning also assists in the performance of maintenance and insures the good operating condition of the CCC & EWCC. See Table 6.1-1.

**Table 6.1-1
Cleaning Procedures**

SURFACE	OIL/GREASE	SALT/MUD/DIRT/DEBRIS	RUST/CORROSION
Exterior and Interior Surfaces (All)	Detergent, Water, Rags	Soapy Water, Brush, Rags	Corrosion Removal Compound and Wire Brush, Dry Rag, Coat with Lube Oil or Spot Paint
Fabric safety straps	Detergent, Water, Rags	Soapy Water, Brush	N/A
Storage box seals and gaskets	Damp and Dry Rags	Damp and Dry Rags	N/A
CCC EWCC Floor	Detergent, Water, Rags	Soapy Water, Brush, Rags	Dry Rags, Coat with Lube Oil or Spot Paint
EWCC Door Hinges, Drawer/Shelf Glides, Rollers and Floor Tracks	N/A	Brush, Rag and lubricate as needed to ensure rails travel freely	Corrosion Removal Compound and Wire Brush, Dry Rags and Lubricate as needed

6.2 Lubrication. Lubrication is performed after cleaning, periodic events and prior to storage to insure good operation and prevention of corrosion of moving parts. **See Table 6.2-1.**

**Table 6.2-1
Lubrication Procedures**

USAGE	FLUID LUBRICANT	CAPACITIES	EXPECTED TEMPERATURES	INTERVAL
Drawer/Shelf Slides, Pins, Floor Locking Mechanisms	OE/HDO	As Required	All Temperatures	Monthly or as Required if under Adverse Situations
Storage Box Door Locks, hinges, Handles	Lubricating Oil, General Purpose Preservative	As Required	All Temperatures	Monthly or as Required if under Adverse Situations

6.3 PMCS. Preventative Maintenance Checks and Services (PMCS) should be performed at the established periods in order to insure smooth and proper operation of the equipment in the system. **See Table 6.3-1.**

**Table 6.3-1
Preventive Maintenance Checks and Services (PMCS)**

PMCS B (Before) D (During) A (After) W (Weekly) M (Monthly)

#	B	D	A	W	M	INSPECTION ITEM AND PROCEDURE	EQUIPMENT NOT READY/AVAILABLE IF
1	*	*	*			Storage Boxes, Roll out Workstations, Walls, EWCC Check all doors and walls for cracks, dents, holes, or loose/missing hardware.	Missing doors, punctures, damage that would cause hazard or injury.
					*	Lubricate hinges, locks floor rails as required.	
2			*	*		Exterior Check all exterior surfaces for cracks and dents that effect the operation of the EWCC & CCC. Check for accumulations of dirt, debris, ice, snow, or salt. Clean as required. Check EWCC & CCC floor for dirt and debris. Clean with broom or rags as required. Check EWCC workstation Lock devices for cracks or missing latches, pins and lanyards. Check workstation for damaged or missing locking jack-straps and for missing or loose lock pins, linchpins and lanyards. Replace or tighten as necessary.	Damage that would cause malfunction of the EWCC workstation systems such as lock-down devices would cause injury. Missing or damaged pins would cause injury by not securing the workstation. Replace any missing or damaged pins.
3			*		*	Data Plates Check plates for legibility, damage and/or absence. Clean with water and rag. Replace as needed.	Missing data will impair maritime shipment.

6.4 Repairs

Repair, adjustment and replacement of parts can be accomplished with a General Mechanic's Tool set (NSN 5180-01-454-3787).

6.5 Technical and Replacement Part Web Information Sources

**Table 6.5-1
Technical and Replacement Part Information Sources**

FUNCTION	TECH MAUNEL & TITLE	MFG. WEB SITE / ADDRESS & PHONE NUMBER
HVAC	TWINTEMP MODEL EM18J34B TECH WEB LIBRARY FRIEDRICH OPERATING GUIDE & INSTALLATION INSTRUCTION LOCATED IN THE FILE CABINET	HTTP/WWW.FRIEDRICH.COM/PDF/
BODY REPAIR & WELDING	TM9-237 Welding Theory and Application TM9-510 Metal Body Repair and Related Operation	WWW.LOGSA.COM WWW.TRAINARMY.MIL

6.6 Troubleshooting

Review the Safety Summary on pages iv to vii prior to any CCC & EWCC Movement, Service or Operation of the EWCC Workstations.

**Table 6.6-1
Troubleshooting Checks**

FUNCTION	CHECKS
CCC & EWCC Operation Section 4.3	
EWCC Workstation will not roll out	<ol style="list-style-type: none"> 1. Insure that the material stored inside is not obstructing the floor rollers operation. 2. Check for exterior ground obstructions, i.e. rocks or dirt.
HVAC is Overheating	<ol style="list-style-type: none"> 1. Insure the weather cover has been removed. 2. Inspect the filter and replace if necessary. 3. Inspect the Freon charge. 4. Recharge the Freon.
No Electrical Power	<ol style="list-style-type: none"> 1. Insure that the external electrical power source or generator is properly connected, operating and grounded, i.e. power generator or extension cord to a domestic facility AC power source. 2. Insure the power connection cables make firm connection. See Section VII. 3. Check and reset circuit breakers.

THIS PAGE INTENTIONALLY LEFT BLANK

SECTION VII
CCC and EWCC ELECTRICAL COMMUNICATION DIAGRAMS

THIS PAGE INTENTIONALLY LEFT BLANK

SECTION VII
CCC AND EWCC ELECTRICAL COMMUNICATION DIAGRAMS

7.1 EWCC Electrical and Communication Diagrams

Figure 7.1-1
EWCC Top Layout

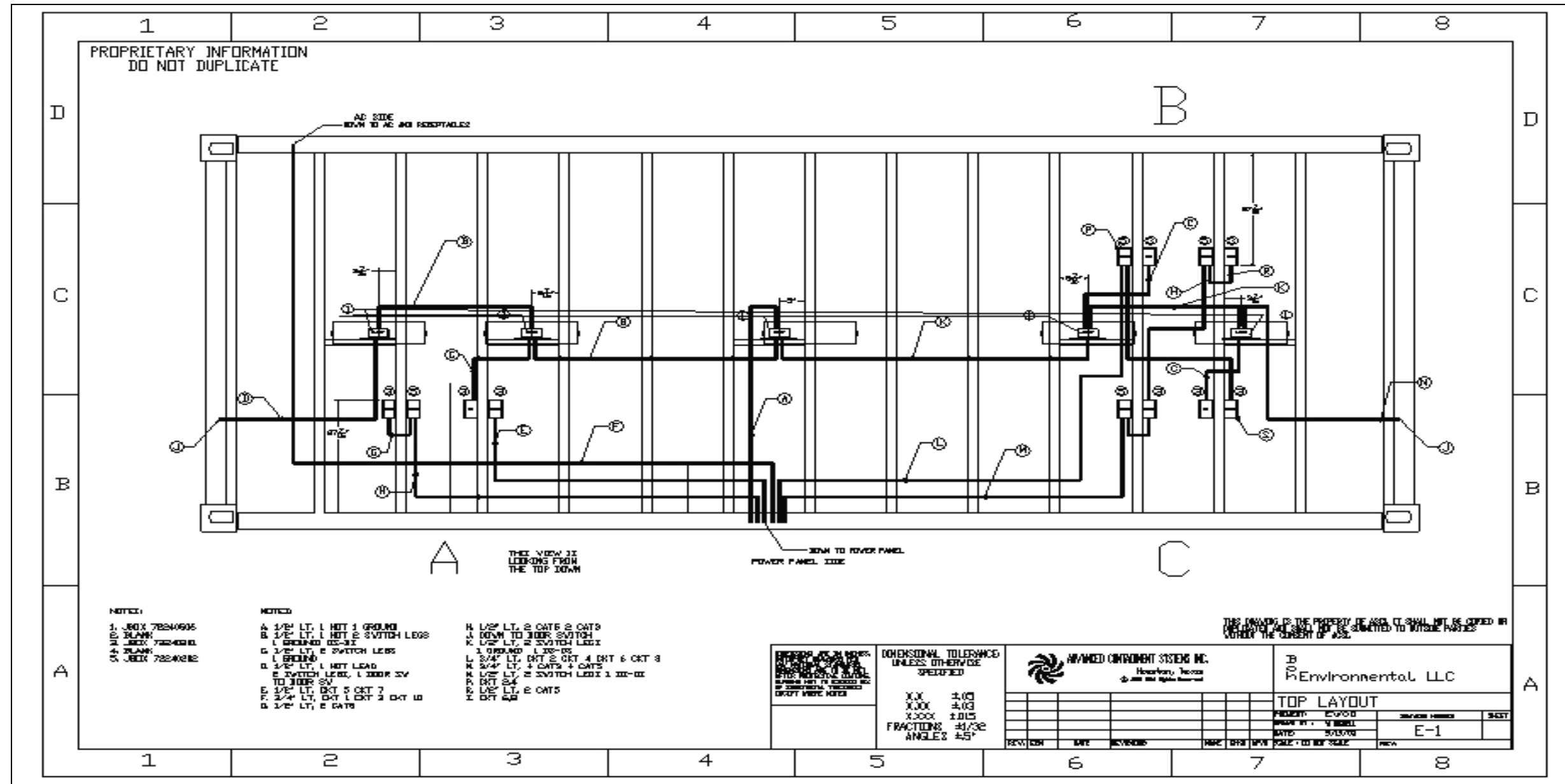

Figure 7.1-2
AC Side Layout

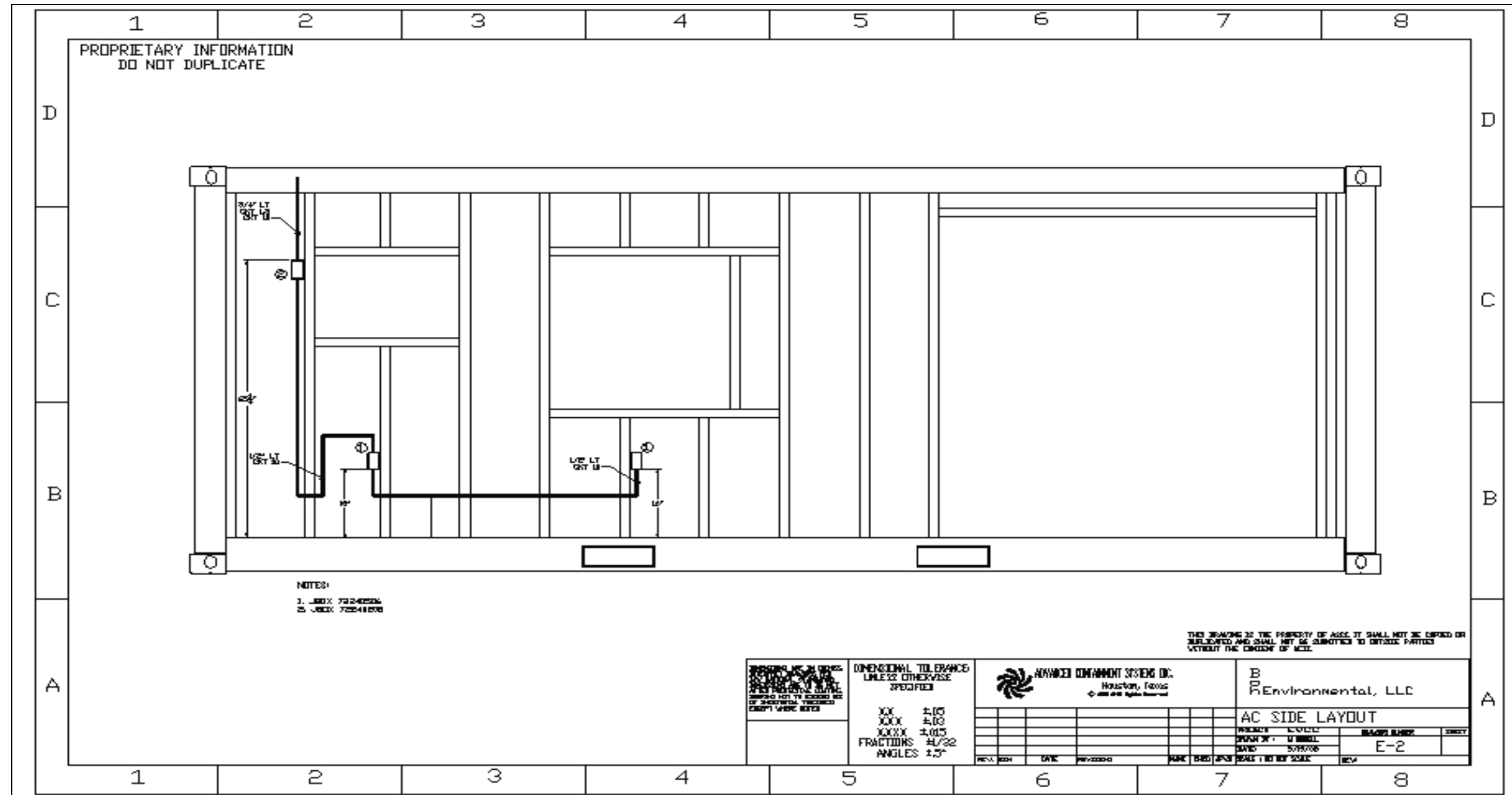

Figure 7.1-3
EWCC Load Center Layout

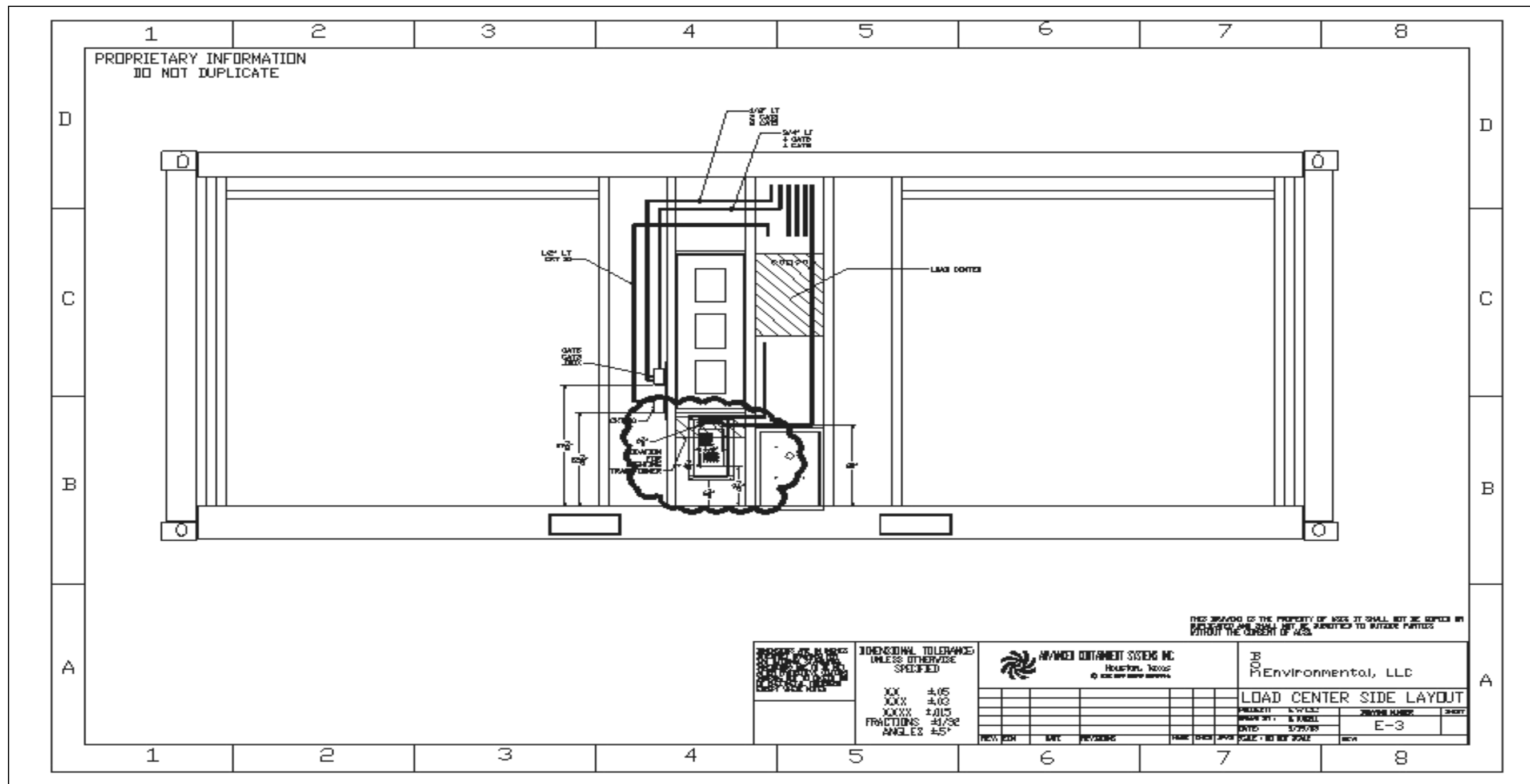

Figure 7.1-4
EWCC End Layout

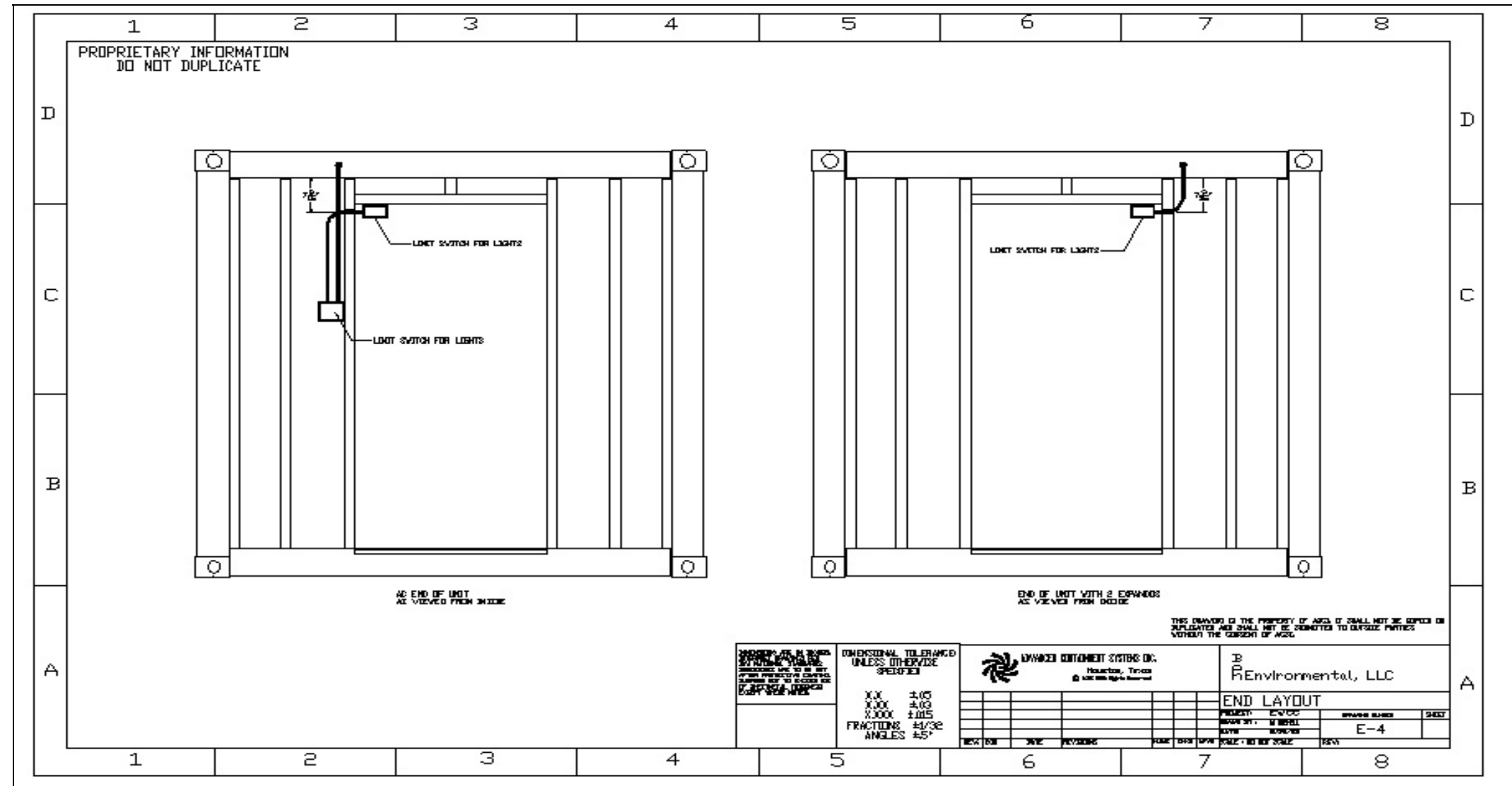

Figure 7.1-5
CCC Load Center Layout



Figure 7.1-6
CCC and EWCC Power Phase Hook-Up



Black Wire Lien 1
 Black & Red Wire Line 2
 Black & White Wire Neutral
 Green Wire Ground

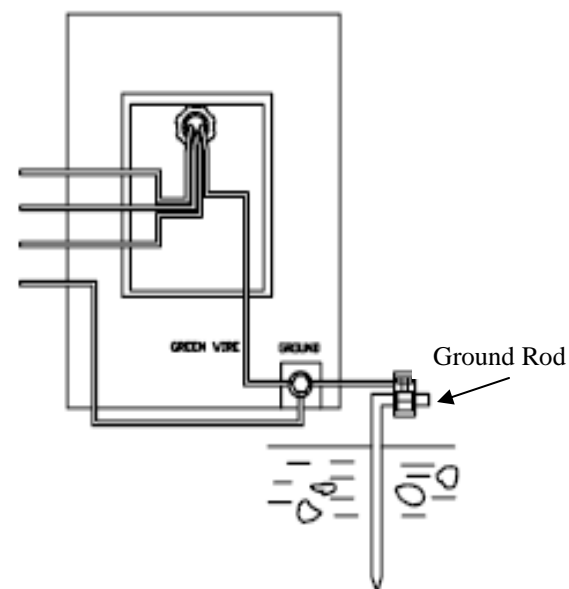

NOTES:

TO POWER THE UNIT:

YOU MUST HAVE 240 VOLTS SINGLE PHASE,
 AND WIRES NO SMALLER THAN AWG #8

CONNECT LINE ONE TO SOLID BLACK WIRE

CONNECT LINE TWO TO BLACK, RED MARKED WIRE

NEUTRAL MUST BE CONNECTED TO BLACK, WHITE MARKED WIRE

GROUND MUST BE CONNECTED TO GROUND BOLT,
 AT THIS SAME POINT, YOU NEED TO CONNECT THE
 GROUND ROD TERMINAL AND INSTALL GROUND ROD TO
 SOIL

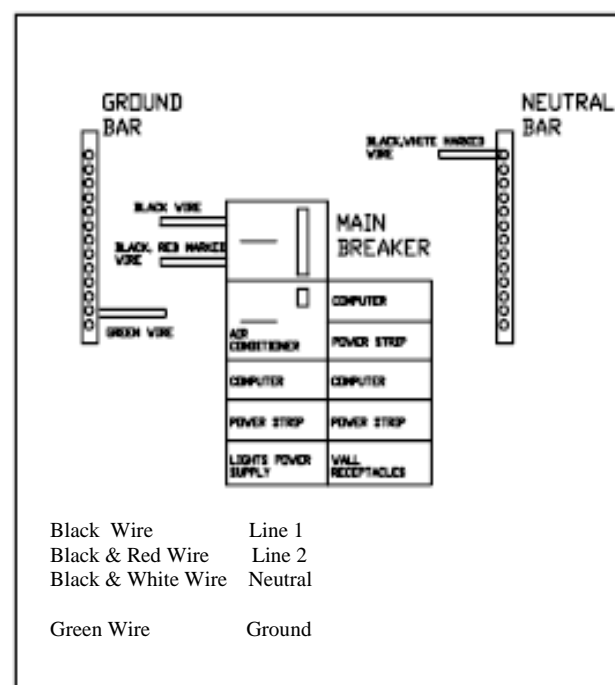

Black Wire Line 1
 Black & Red Wire Line 2
 Black & White Wire Neutral
 Green Wire Ground

Figure 7.1-7
CCC and EWCC Communications Layout

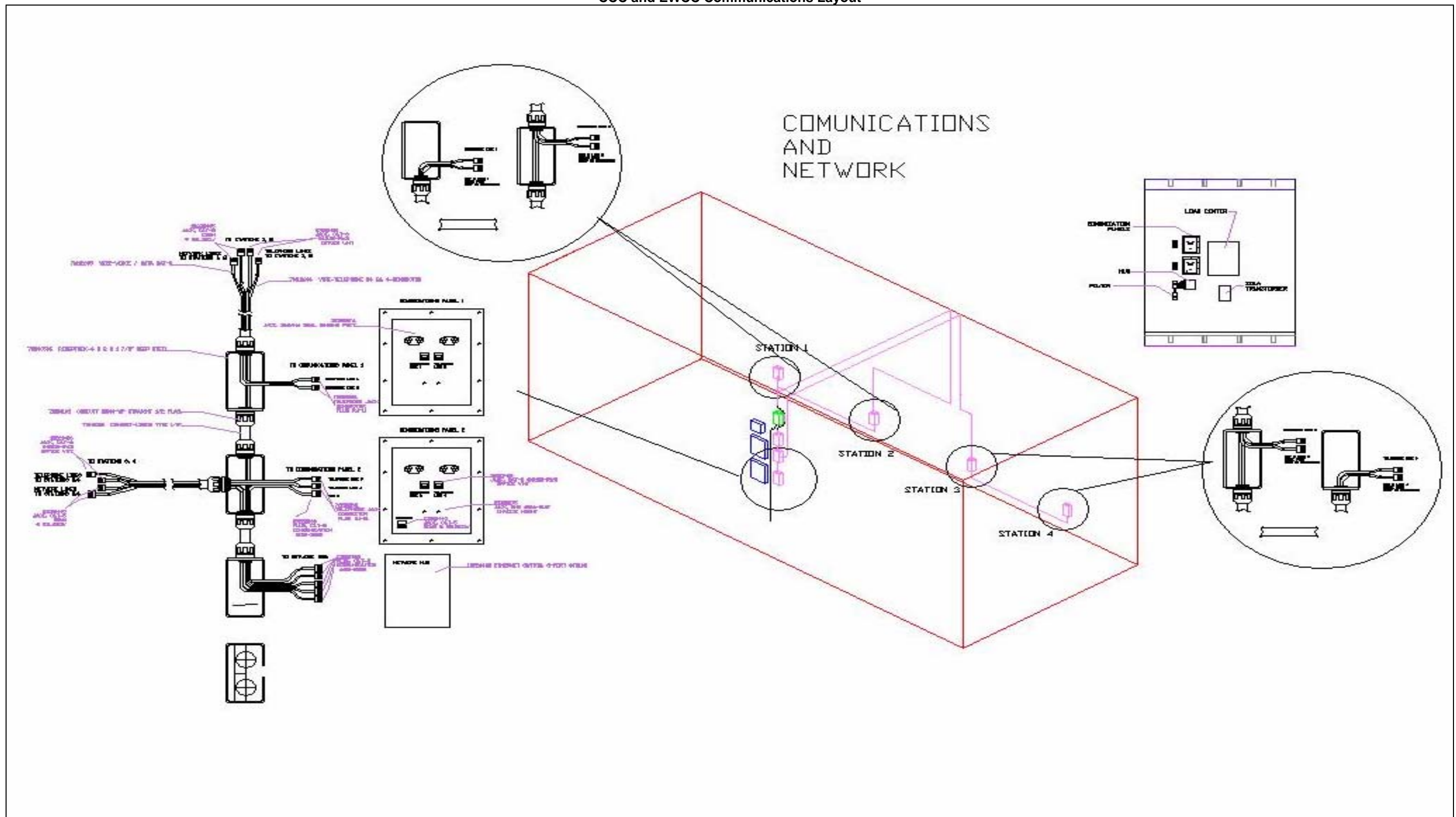

SECTION VIII
CCC and EWCC PARTS LISTS

THIS PAGE INTENTIONALLY LEFT BLANK

THIS PAGE INTENTIONALLY LEFT BLANK

SECTION IX
CCC and EWCC WARRANTY

THIS PAGE INTENTIONALLY LEFT BLANK

Boh Environmental, L.L.C

MANUFACTURER'S LIMITED WARRANTY TERMS

Boh Environmental, LLC (BOH) warrants that the Products, including the Field Pack-Up (FPU) Systems and other Containerized Mission Systems it manufactures, shall be free from defects in materials and workmanship for a period of one year from date of purchase when normally used and operated by the Customer. Unused Product containing missing or defective components shall be returned within the warranty period, with proof of purchase, to BOH with transportation charges prepaid. BOH, at its option, shall supply a replacement item(s) or refund the purchase price of the Product. BOH will determine, at its sole discretion, that the claim is a valid warranty item. If so, BOH will pay costs (actual transportation plus handling charge) for shipping of the replacement item, when this option is selected.

This warranty is void if Products have been damaged by the Customer as the result of improper or unreasonable use, or other causes not arising out of defects in material or workmanship. The warranty is also void if the Product has at any time been stored or used other than in accordance with the directions set out in the literature relating to the Product. BOH makes no other warranty or representation concerning the Products except that each will meet the performance specifications set forth in the literature relating to the Product. There are no further warranties, including any warranty of merchantability or fitness for a particular purpose covering the Product.

BOH will, at its option, either (1) credit user in the amount paid for any Product which does not perform to these specifications, or (2) replace such Product, provided user so notifies BOH within twelve (12) months of the Product's purchase date. BOH shall not be responsible for any consequential damages to user arising as a result of such performance. The Customer will return the item at their cost. If required, BOH may elect to have a representative inspect the item to validate the claim.

Other product components included in the fabrication of items purchased under contract (e.g. air conditioners and generators), that are not manufactured by Boh Environmental, are warranted by their individual manufacturer. Copies of such warranties are supplied with the finished Product or are available through Boh Environmental.

www.bohenvironmental.com

BOH Environmental, LLC
FPU Mobility Systems Division
4116C Walney Road
Chantilly, VA 20151
BOH FPU Systems
Telephone (703) 449-6020 / Fax (703) 449-6022