

Fast Responding Quartz Tube Panel

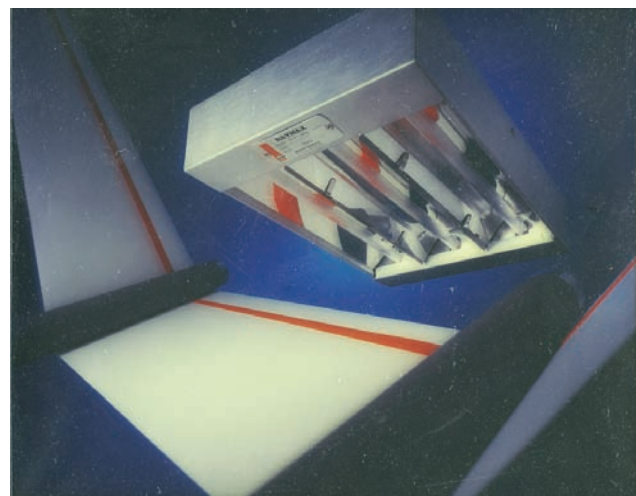

Watlow's RAYMAX® 1626 quartz tube panel is a fast responding and very efficient source of radiant thermal energy. With heat-up and cool down capabilities of 40 to 50 seconds, the quartz heater is ideal for use in operations where frequent line stoppages are anticipated or immediate heat-up and cool-down is necessary. Custom sizes are available up to 27 inches wide in three inch increments and 70 inches long.

Applications

- Heating plastic films
- Ink drying
- Coating curing
- Fusing powder coating
- Activating adhesives

Features and Benefits

Quartz tubes and reflectors are easy to replace

- Less downtime waiting for parts

Polished parabolic aluminum reflectors

- Direct radiant energy from the back for efficient heating

Little residual heat

- Reduces possibility of product damage during line stoppage

Fast heat-up, cool down allows heater turn off during gaps in production

- Energy savings

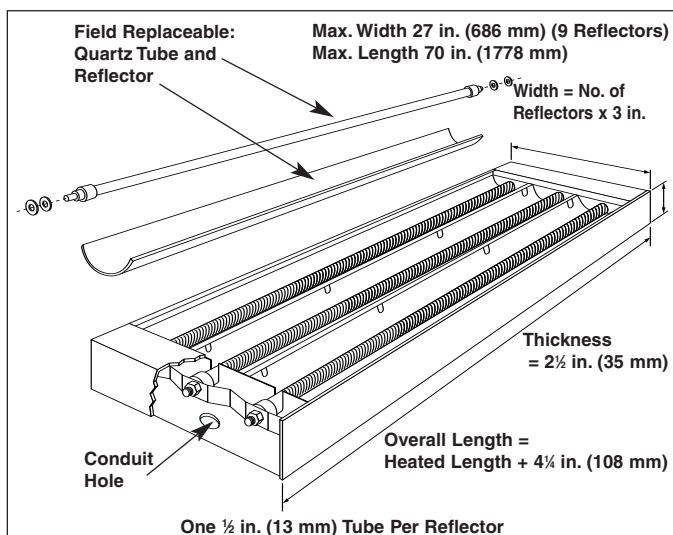

STL-1626-0805

12001 Lackland Road
St. Louis, Missouri 63146 USA
Phone: +1 (314) 878-4600
FAX: +1 (314) 878-6814
Internet: www.watlow.com
e-mail: info@watlow.com

To be automatically connected to the nearest North American Technical and Sales Office call:

1-800-WATLOW2

International Technical and Sales Offices: China, +86 (21) 5211-0231 • France, +33 (01) 3073-2425 • Germany, +49 (0) 7253-9400-0 • Italy, +39 (02) 458-8841 • Japan, +81 (03) 3518-6630 • Korea, +82 (02) 575-9804 • Malaysia, +60 (4) 641-5977 • Mexico, +52 (442) 217-6235 • Singapore, +65 6773-9488 • Spain, +34 91 675 12 92 • Sweden, +46 31 7014959 • Taiwan, +886 (0) 7-288-5168 • United Kingdom, +44 (0) 115-964-0777

