

RAYMAX® 1220 AND 2030

Raymax® 1220 and 2030—Ideal For Many Process Heating Applications Requiring "Hot Face" Temperatures



Easy to install and capable of high surface temperatures, the RAYMAX® 1220 and 2030 are ideal for many process heating applications requiring "hot face" temperatures above 540°C (1000°F).

Each unit consists of a ceramic fiber heater mounted in a 2.5 inch (64 mm) deep sheet metal case that provides thermal insulation. The case includes post terminals for electrical connections and provides a mounting system that can be used with virtually any flat ceramic fiber unit, whether it is a stock, standard or a custom size. Since any of the flat unit heating element configurations can be used—exposed sinuated, embedded coil or foil elements—watt density and temperature capabilities can be tailored to meet specific radiant applications.

Applications

- Conveyor furnaces
- High temperature vessel heating
- Tempering and annealing processes for glass, wire, ceramics and metals
- Coating, curing and drying of inks, paints, plastics and films

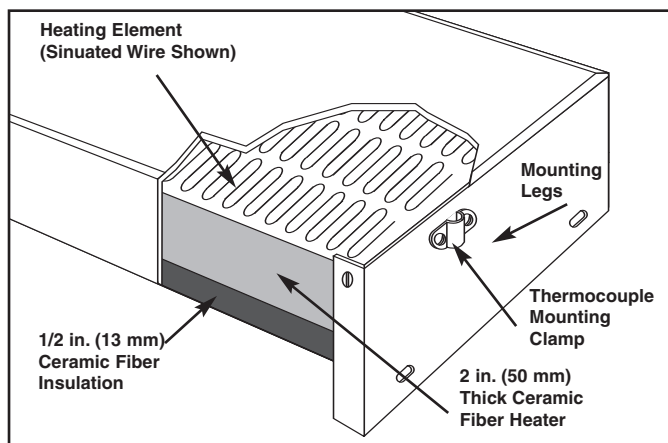

Features and Benefits

Lightweight, low mass design

- Allows fast response to controls

High efficiency

- Results from high degree of self insulation with 2.5 inch (64 mm) thick mounting case

Adaptable

- With any stock or standard sized flat ceramic fiber unit

Thermocouple mounting clamp

- Makes process system control easier

Aluminized steel case

- Handles temperatures up to 595°C (1100°F)

Special hot face heating patterns

- Designed specifically for applications using an etched foil RAYMAX 1220



WATLOW

STL-1220/2030-0805

12001 Lackland Road
St. Louis, Missouri 63146 USA
Phone: +1 (314) 878-4600
FAX: +1 (314) 878-6814
Internet: www.watlow.com
e-mail: info@watlow.com



Applications and Technical Data Specifications

Weight: Under 6.5 lbs/ft² (31.75 kg/m²)

Voltage and Wattage: Ratings are based on the ceramic fiber heater module, which is mounted in the case. Up to 600V~(ac) is possible.

Terminals: Terminals are ¼-20 threaded studs. Two terminals plus ground for single-phase, and three terminals plus ground for three-phase, are standard. They will be located on the center line of the length unless otherwise specified. Terminals can be located anywhere along lines A and B (see illustration), but not closer than two inches (51 mm) to the case ends.

Mounting Legs

- One inch (25 mm) standard
- Three inches (76 mm) optional from stock. For made-to-order units, mounting legs can be supplied in any incremental length L from ½ inch (13 mm) to three inches (76 mm). No slots are provided in legs less than one inch long.

Application Hints: A thermocouple mounting clamp will be provided on one end of the case, with holes on both ends for alternate locations. The standard clamp can be used with ½-inch (3.2 mm) O.D. sheath thermocouples. The standard clamp is ⅝ inch (4.8 mm) high, but can be removed for flush mounting*. The maximum recommended surface temperature of the heater is based on the rating of the ceramic fiber heater module. This can vary from 1095°C (2000°F) at lower watt densities, to higher watt densities at reduced surface temperatures. Note that maximum wattages cannot be achieved at the maximum temperatures simultaneously.

Heater Dimensions	Min.	Max.	Increments
Width: inches (mm)	2 (51)	30 (760)	Any
Length: inches (mm)	6 (152)	52 (1320)	Any

Note: Units will be ¼ inch (6 mm) wider than the nominal size of the ceramic fiber heater. Overall length is equal to heater length, but thermocouple clamp not included in length.

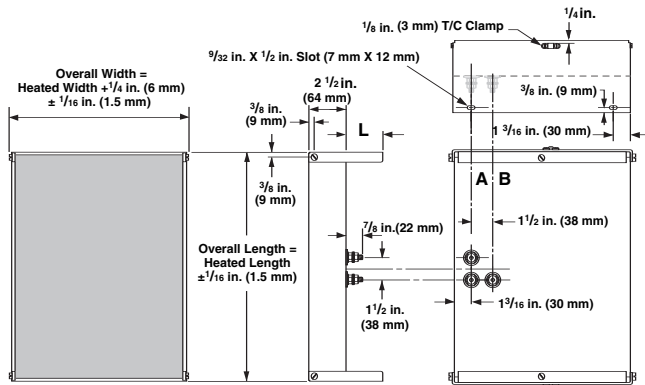

* ½ inch (3.2 mm) is standard. ⅝ inch (4.8 mm) and ¾ inch (6 mm) are available upon request.

Options

Several options are available with RAYMAX 1220 and 2030 models. Consult Watlow for more information on any of the options.

- Single-phase non-standard location power terminals
- Terminal box
- Zoning
- Mounting studs and legs
- Three-phase construction
- Thermocouple mounting tubes
- Alternate case materials

How to Order

To order a **stock**, **assembly stock**, or **standard** heater, specify:

- RAYMAX 1220 or 2030
- Quantity
- Watlow code number (from Watlow heater's catalog)
- Mounting studs, if desired

Note: One-inch mounting legs are provided. Three-inch legs are available from stock upon request.

If our stock or standard units do not meet your application needs, Watlow can manufacture radiant heaters to your special requirements.

For **made-to-order** units, please specify, in addition to above information:

- Heated width and length and overall size
- Total wattage
- Voltage, and phases or zones required
- Load temperature expectations
- Mounting studs, if desired
- Mounting legs and leg height, if desired (one inch is provided unless otherwise specified)
- Location of terminals
- Terminal box, if desired
- Thermowell (specify size and location if standard end clamp is not sufficient)

Supplying a drawing with an order or request for quotation can be very helpful in clarifying design information.

Availability

Stock: Shipment in one to two days

Assembly Stock: Shipment in two weeks

Standard: Shipment in three to four weeks

Made-to-Order: Consult Watlow

To be automatically connected to the nearest North American Technical and Sales Office call:

1-800-WATLOW2

International Technical and Sales Offices: China, +86 (21) 5211-0231 • France, +33 (01) 3073-2425 • Germany, +49 (0) 7253-9400-0 • Italy, +39 (02) 458-8841 • Japan, +81 (03) 3518-6630 • Korea, +82 (02) 575-9804 • Malaysia, +60 (4) 641-5977 • Mexico, +52 (442) 217-6235 • Singapore, +65 6773-9488 • Spain, +34 91 675 12 92 • Sweden, +46 31 7014959 • Taiwan, +886 (0) 7-288-5168 • United Kingdom, +44 (0) 115-964-0777