

## **PPC-153**

Pentium® III processor-based  
panel PC with 15" LCD flat panel  
display

**User's Manual**

## **Copyright notice**

This document is copyrighted 2001, by Advantech Co., Ltd. All rights are reserved. Advantech Co., Ltd. reserves the right to alter the products described in this manual at any time without notice.

No part of this manual may be reproduced, copied, translated or transmitted in any form or by any means without the prior written permission of Advantech. Information provided in this manual is intended to be accurate and reliable. However, Advantech assumes no responsibility for use of this manual, nor for any infringements upon the rights of third parties which may result from such use.

All brand and product names mentioned herein are trademarks or registered trademarks of their respective holders.

## **FCC Class B**

This equipment has been tested and found to comply with the limits for a Class B digital device, pursuant to Part 15 of the FCC Rules. These limits are designed to provide reasonable protection against harmful interference when the equipment is operated in a residential environment. This equipment generates, uses and can radiate radio frequency energy. If not installed and used in accordance with this user's manual, it may cause harmful interference to radio communications. Note that even when this equipment is installed and used in accordance with this user's manual, there is still no guarantee that interference will not occur. If this equipment is believed to be causing harmful interference to radio or television reception, this can be determined by turning the equipment on and off. If interference is occurring, the user is encouraged to try to correct the interference by one or more of the following measures:

- Reorient or relocate the receiving antenna
- Increase the separation between the equipment and the receiver
- Connect the equipment to a power outlet on a circuit different from that to which the receiver is connected
- Consult the dealer or an experienced radio/TV technician for help

*Warning: Any changes or modifications made to the equipment which are not expressly approved by the relevant standards authority could void your authority to operate the equipment.*

# Packing List

---

Before installing your panel PC, ensure that the following materials have been received:

- PPC-153 series panel PC
- User's manual
- Accessories for PPC-153
  - Y-shaped adapter for PS/2 mouse and keyboard
  - Power cord (1.8 m) - USA type (other types are available on request)
  - Floppy disk with CD-ROM drive driver
  - "Drivers and Utilities" CD-ROM disc
  - Mounting kits and packet of screws
  - Heat sink (optional) (refer to Notes 1 and 2 below)

If any of these items are missing or damaged, contact your distributor or sales representative immediately.

*Note 1: If the unit you have bought is basic (i.e. without a CPU, HDD, or SDRAM), you will find this optional item in the accessory box.*

*Note 2: If you install an Intel® processor yourself, you must install a heat sink above the CPU. This will avoid heat damage to the CPU.*

## Additional Information and Assistance

---

1. Visit the Advantech websites at **www.advantech.com** or **www.advantech.com.tw** where you can find the latest information about the product.
2. Contact your distributor, sales representative, or Advantech's customer service center for technical support if you need additional assistance. Please have the following information ready before you call:
  - Product name and serial number
  - Description of your peripheral attachments
  - Description of your software (operating system, version, application software, etc.)
  - A complete description of the problem
  - The exact wording of any error messages

### **Warning!**



1. *Input voltage rated 100-250 V<sub>AC</sub>, 50/60 Hz, 3 A*
2. *Use a 3 V @ 195 mA lithium battery*
3. *Packing: please carry the unit with both hands, handle with care*

#### *4. Our European representative:*

*Advantech Europe GmbH  
Kolberger Straße 7  
D-40599 Düsseldorf, Germany  
Tel: 49-211-97477350  
Fax: 49-211-97477300*

5. *Maintenance: to properly maintain and clean the surfaces, use only approved products or clean with a dry applicator*

# Safety Instructions

---

1. Read these safety instructions carefully.
2. Keep this User's Manual for later reference.
3. Disconnect this equipment from any AC outlet before cleaning. Use a damp cloth. Do not use liquid or spray detergents for cleaning.
4. For plug-in equipment, the power outlet socket must be located near the equipment and must be easily accessible.
5. Keep this equipment away from humidity.
6. Put this equipment on a reliable surface during installation. Dropping it or letting it fall may cause damage.
7. The openings on the enclosure are for air convection. Protect the equipment from overheating. **DO NOT COVER THE OPENINGS.**
8. Make sure the voltage of the power source is correct before connecting the equipment to the power outlet.
9. Position the power cord so that people cannot step on it. Do not place anything over the power cord.
10. All cautions and warnings on the equipment should be noted.
11. If the equipment is not used for a long time, disconnect it from the power source to avoid damage by transient overvoltage.
12. Never pour any liquid into an opening. This may cause fire or electrical shock.
13. Never open the equipment. For safety reasons, the equipment should be opened only by qualified service personnel.
14. If one of the following situations arises, get the equipment checked by service personnel:
  - a. The power cord or plug is damaged.
  - b. Liquid has penetrated into the equipment.
  - c. The equipment has been exposed to moisture.
  - d. The equipment does not work well, or you cannot get it to work according to the user's manual.
  - e. The equipment has been dropped and damaged.
  - f. The equipment has obvious signs of breakage.
15. **DO NOT LEAVE THIS EQUIPMENT IN AN UNCONTROLLED ENVIRONMENT WHERE THE STORAGE TEMPERATURE IS BELOW -20° C (-4° F) OR ABOVE 60° C (140° F). THIS MAY DAMAGE THE EQUIPMENT.**

The sound pressure level at the operator's position according to IEC 704-1:1982 is no more than 70dB(A).

**DISCLAIMER:** This set of instructions is given according to IEC 704-1. Advantech disclaims all responsibility for the accuracy of any statements contained herein.

# Wichtige Sicherheitshinweise

---

1. Bitte lesen Sie sich diese Hinweise sorgfältig durch.
2. Heben Sie diese Anleitung für den späteren Gebrauch auf.
3. Vor jedem Reinigen ist das Gerät vom Stromnetz zu trennen. Verwenden Sie keine Flüssig- oder Aerosolreiniger. Am besten dient ein angefeuchtetes Tuch zur Reinigung.
4. Die Netzanschlusssteckdose soll nahe dem Gerät angebracht und leicht zugänglich sein.
5. Das Gerät ist vor Feuchtigkeit zu schützen.
6. Bei der Aufstellung des Gerätes ist auf sicheren Stand zu achten. Ein Kippen oder Fallen könnte Verletzungen hervorrufen.
7. Die Belüftungsöffnungen dienen zur Luftzirkulation, die das Gerät vor Überhitzung schützt. Sorgen Sie dafür, dass diese Öffnungen nicht abgedeckt werden.
8. Beachten Sie beim Anschluss an das Stromnetz die Anschlusswerte.
9. Verlegen Sie die Netzanschlussleitung so, dass niemand darüber fallen kann. Es sollte auch nichts auf der Leitung abgestellt werden.
10. Alle Hinweise und Warnungen, die sich an den Geräten befinden, sind zu beachten.
11. Wird das Gerät über einen längeren Zeitraum nicht benutzt, sollten Sie es vom Stromnetz trennen. Somit wird im Falle einer Überspannung eine Beschädigung vermieden.
12. Durch die Lüftungsöffnungen dürfen niemals Gegenstände oder Flüssigkeiten in das Gerät gelangen. Dies könnte einen Brand bzw. elektrischen Schlag auslösen.
13. Öffnen Sie niemals das Gerät. Das Gerät darf aus Gründen der elektrischen Sicherheit nur von autorisiertem Servicepersonal geöffnet werden.
14. Wenn folgende Situationen auftreten, ist das Gerät vom Stromnetz zu trennen und von einer qualifizierten Servicestelle zu überprüfen:
  - a - Netzkabel oder Netzstecker sind beschädigt.
  - b - Flüssigkeit ist in das Gerät eingedrungen.
  - c - Das Gerät war Feuchtigkeit ausgesetzt.
  - d - Wenn das Gerät nicht der Bedienungsanleitung entsprechend funktioniert oder Sie mit Hilfe dieser Anleitung keine Verbesserung erzielen.
  - e - Das Gerät ist gefallen und/oder das Gehäuse ist beschädigt.
  - f - Wenn das Gerät deutliche Anzeichen eines Defektes aufweist.
15. Bitte lassen Sie das Gerät nicht unbehebt hinten unter  $-20^{\circ}\text{C}$  ( $-4^{\circ}\text{F}$ ) oder oben  $60^{\circ}\text{C}$  ( $140^{\circ}\text{F}$ ), weil diesen Temperaturen das Gerät zerstören könnte.

Der arbeitsplatzbezogene Schalldruckpegel nach DIN 45 635 Teil 1000 beträgt 70 dB(A) oder weniger.

DISCLAIMER: This set of instructions is given according to IEC704-1. Advantech disclaims all responsibility for the accuracy of any statements contained herein.

# Contents

<b>CHAPTER 1 General Information</b>	<b>1</b>
1.1 Introduction .....	2
1.2 How to Use This Manual .....	4
1.3 Specifications .....	6
General .....	6
Standard PC functions .....	6
Flat panel interface .....	7
Audio function .....	7
PCI bus Ethernet interface .....	8
PCMCIA interface .....	8
Touchscreen (optional) .....	9
Optional modules .....	9
Environment .....	10
1.4 Dimensions .....	11
<b>CHAPTER 2 System Setup</b>	<b>13</b>
2.1 A Quick Tour of the Panel PC .....	14
2.2 Preparing For First-time Use .....	17
2.3 Installation Procedures .....	17
2.3.1 Connecting the power cord .....	17
2.3.2 Installing the DC power insulator with hood .....	18
2.3.3 Connecting the keyboard and mouse .....	21
2.3.4 Switching on the power .....	21
2.4 Running the BIOS Setup Program .....	22
2.5 Installing System Software .....	23
2.6 Installing the Drivers .....	24
<b>CHAPTER 3 Using the Panel PC</b>	<b>27</b>
3.1 Introduction .....	28
3.2 Floppy Drive .....	28



3.3 CD-ROM Drive .....	29
3.4 PCMCIA .....	30
3.5 PS/2 Mouse and Keyboard .....	33
3.6 PCI/ISA Bus Expansion .....	33
3.7 Parallel Port .....	35
3.8 Serial COM Ports .....	35
3.9 VGA Port .....	36
3.10 Game Port .....	36
3.11 USB Ports .....	36
3.12 Audio Interface .....	37
3.13 Ethernet .....	37
3.14 Adjusting the LCD Contrast and Brightness .....	37
3.15 Touchscreen (Optional) .....	38

**CHAPTER 4 Hardware Installation and Upgrading 39**

4.1 Overview of Hardware Installation and Upgrading .....	40
4.2 Disassembling the Panel PC .....	40
4.3 Installing the 2.5" Hard Disk Drive (HDD) .....	42
4.4 Installing the Central Processing Unit (CPU) .....	43
4.5 Installing the SDRAM Memory Module .....	46
4.6 Installing the Floppy Disk Drive (FDD) and Slim CD-ROM Drive .....	47

**CHAPTER 5 Jumper Settings and Connectors 49**

5.1 Jumpers and Connectors .....	50
5.1.1 Setting jumpers .....	50
5.1.2 Jumpers and switch .....	51
5.1.3 Locating jumpers and switch .....	52
5.1.4 Connectors .....	53
5.1.5 Locating connectors .....	54
5.2 CPU Installation .....	55
5.3 CMOS Clear for External RTC (JP8) .....	55

5.4 COM-port Interface .....	56
5.4.1 COM2 RS-232/422/485 setting (JP3, JP4, JP5) .....	56
5.4.2 COM1 / COM2 pin 9 output type setting (JP9) .....	57
5.4.3 COM3 / COM4 pin 9 output type setting (JP6) .....	58
5.5 Internal -12 V Source Selection Setting (JP1) .....	58
5.6 VGA Interface .....	59
5.6.1 LCD panel power setting .....	59
5.6.2 Panel type select (SW3) .....	59
5.7 Watchdog Timer Configuration .....	60
5.7.1 Watchdog activity selection (JP7) .....	60

## **CHAPTER 6 PCI Bus Ethernet Interface** **61**

6.1 Introduction .....	62
6.2 Installation of Ethernet Driver .....	62
6.2.1 Installation for Windows 95 .....	63
6.2.2 Installation for Windows 98 .....	65
6.2.3 Installation for Windows NT .....	68
6.2.4 Installation for Windows 2000/ME .....	70
6.3 Further Information .....	70

## **CHAPTER 7 AGP SVGA Setup** **71**

7.1 Introduction .....	72
7.1.1 Chipset .....	72
7.1.2 Display memory .....	72
7.1.3 Display types .....	72
7.2 Installation of SVGA Driver .....	73
7.2.1 Installation for Windows 95/98 .....	74
7.2.2 Installation for Windows NT .....	75
7.2.3 Installation for Windows 2000 .....	76
7.2.4 Installation for Windows ME .....	77
7.3 Further Information .....	78

## **CHAPTER 8 Audio** **79**

8.1 Introduction .....	80
8.2 Installation of Audio Driver .....	80

8.2.1 Installation for Windows 95/98 .....	81
8.2.2 Installation for Windows NT .....	83
8.2.3 Installation for Windows 2000/ME .....	84

**CHAPTER 9 Award BIOS Setup 85**

9.1 Award BIOS Setup .....	86
9.2 CMOS Setup Utility .....	86
9.3 Standard CMOS Setup .....	87
9.3.1 Hard disk configurations .....	88
9.4 BIOS Features Setup .....	89
9.5 Chipset Features Setup .....	93
9.6 Power Management Setup .....	95
9.7 PNP/PCI Configuration Setup .....	98
9.8 Load BIOS Defaults .....	99
9.9 Load Setup Defaults .....	100
9.10 Integrated Peripherals .....	100
9.11 Password Setting .....	102
9.12 IDE HDD Auto Detection .....	103
9.13 Save and Exit Setup .....	104
9.14 Exit Without Saving .....	104

**CHAPTER 10 PCMCIA 105**

10.1 Introduction .....	106
10.2 Installation of PCMCIA Driver .....	106
10.2.1 Installation for Windows 95 .....	107

**CHAPTER 11 Touchscreen 109**

11.1 Introduction .....	110
11.1.1 General information .....	110
11.1.2 General specifications .....	110
11.1.3 Environmental specifications .....	110
11.2 Installation of Driver for Resistive or SAW Touchscreen .....	111

11.2.1 Installation for Windows 95 .....	112
11.2.2 Installation for Windows 98 .....	114
11.2.3 Installation for Windows NT .....	116
11.2.4 Installation for Windows 2000 .....	118
11.2.5 Installation for Windows ME .....	121
11.3 Installation of Driver for Capacitive Touchscreen ....	123
11.3.1 Installation for Windows 95/98/NT .....	124

**APPENDIX A LCD Specifications and Selection Settings** **127**

A.1 PPC-153T LCD Specifications .....	128
---------------------------------------	-----

**APPENDIX B Programming the Watchdog Timer** **129**

B.1 Programming the Watchdog Timer .....	130
--	-----

**APPENDIX C Full Disassembly Procedures** **133**

**APPENDIX D Pin Assignments** **141**

D.1 AT Power Connector (J1) .....	142
D.2 TV Output Connector (J2) (*Reserved) .....	142
D.3 Inverter Power Connector (J4) .....	143
D.4 Internal Speaker Connector (J6) (*Reserved) .....	143
D.5 Front Panel Control Connector (J8) (*Reserved) ....	144
D.6 IR Connector (J9) (*Reserved) .....	144
D.7 Flat Panel Display Connector (CN2) .....	145
D.8 Flat Panel Display Connector (CN3) .....	146
D.9 PanelLink Interface (CN4) (*Reserved) .....	147
D.10 Floppy Drive Connector (CN10) .....	148
D.11 EIDE Hard Disk Drive Connector (CN16) .....	149
D.12 CD-ROM Connector (CN18) .....	150
D.13 CPU Fan Power Connector (FAN1) .....	151
D.14 System Fan Power Connector (FAN2) .....	151
D.15 PCI/ISA Bus Expansion Connector (SLOT1) .....	152

D.16 Touchscreen Connector (CN23) ..... 157  
D.17 COM2 ..... 158

**APPENDIX E Mounting Instructions** **159**

E.1 Introduction ..... 160  
E.2 Panel Mounting ..... 160  
    E.2.1 Introduction ..... 160  
    E.2.2 Installation procedure ..... 161  
    E.2.3 Cut-out area ..... 162  
E.3 Desktop Stand Mounting ..... 163  
E.4 Swingarm Stand Mounting ..... 165

# Tables

Table 5-1: Jumpers and their functions .....	51
Table 5-2: Panel PC connectors .....	53
Table 5-3: Clear CMOS / External RTC (JP8) .....	55
Table 5-4: COM2 RS-232/422/485 setting (JP3, JP4) .....	56
Table 5-5: COM2 RS-232/422/485 setting (JP5) .....	56
Table 5-6: Serial port default settings .....	57
Table 5-7: COM1 / COM2 pin 9 output type setting (JP9) .....	57
Table 5-8: COM3/RI pin setting (JP6) .....	58
Table 5-9: Internal -12 V source selection setting (JP1) .....	58
Table 5-10: Panel type select (SW3) .....	59
Table 5-11: Watchdog activity selection (JP7) .....	60
Table D-1: AT power connector (J1) .....	142
Table D-2: TV output connector (J2) .....	142
Table D-3: Inverter power connector (J4) .....	143
Table D-4: Internal speaker connector (J6) .....	143
Table D-5: Front panel control connector (J8) (*Reserved) .....	144
Table D-6: IR connector (J9) (Reserved) .....	144
Table D-7: Flat panel display connector (CN2) .....	145
Table D-8: Flat panel display connector (CN3) .....	146
Table D-9: PanelLink Interface (CN4) (*Reserved) .....	147
Table D-10: Floppy drive connector (CN10) .....	148
Table D-11: EIDE hard disk drive connector (CN16) .....	149
Table D-12: CD-ROM connector (CN18) .....	150
Table D-13: CPU fan power connector (FAN1) .....	151
Table D-14: Fan power connector (FAN2) .....	151
Table D-15: PCI/ISA slot pin assignments (Pins A and B) .....	153
Table D-16: PCI/ISA slot pin assignments (Pins C and D) .....	154
Table D-17: PCI/ISA slot pin assignments (Pins E and F) .....	155
Table D-18: PCI/ISA slot pin assignments (Pins G and H) .....	156
Table D-19: Internal COM4 and PS/2 Connector (CN23) .....	157
Table D-20: COM2 .....	158

# Figures

Figure 1-1: The panel PC in perspective .....	3
Figure 1-2: How to read the PPC-153 manual .....	5
Figure 1-3: Dimensions of the PPC-153 .....	11
Figure 2-1: Front view of the panel PC .....	14
Figure 2-2: Left side view of the panel PC .....	15
Figure 2-3: Rear view of the panel PC .....	16
Figure 2-4: Rear and side view of the panel PC .....	16
Figure 2-5: Connecting the power cord .....	17
Figure 2-6: Connecting the keyboard and mouse .....	21
Figure 3-1: Inserting and ejecting a floppy disk .....	28
Figure 3-2: Inserting and ejecting a CD-ROM disc .....	29
Figure 3-3: Inserting and ejecting a PCMCIA card .....	30
Figure 3-4: Using the I/O interface (upper level ports excluding COM ports) .....	31
Figure 3-5: Using the I/O interface (lower level ports and COM ports) .....	32
Figure 3-6: PCI/ISA bus expansion .....	34
Figure 4-1: Disassembling the plastic rear cover of the panel PC .....	41
Figure 4-2: Installing the primary 2.5" HDD .....	42
Figure 4-3: Installing the CPU .....	45
Figure 4-4: Installing SDRAM .....	46
Figure 4-5: Installing the FDD and slim CD-ROM drive .....	48
Figure 5-1: Locating jumpers on the PPC-153 motherboard .....	52
Figure 5-2: Locating connectors on the PPC-153 motherboard .....	54
Figure 9-1: Setup program initial screen .....	86
Figure 9-2: CMOS setup screen .....	87
Figure 9-3: BIOS features setup screen .....	89
Figure 9-4: Chipset features setup screen .....	93
Figure 9-5: Power management setup screen .....	95
Figure 9-6: PNP/PCI configuration setup screen .....	98
Figure 9-7: Load BIOS defaults screen .....	99
Figure 9-8: Integrated peripherals screen .....	100
Figure 9-9: IDE HDD auto detection screen .....	103
Figure 9-10: Save and exit setup screen .....	104

Figure C-1: Disassembly steps 1 - 4 ..... 135  
Figure C-2: Disassembly steps 5 - 6 ..... 137  
Figure C-3: Disassembly steps 7 - 12 ..... 139  
Figure E-1: Cutout dimensions of the PPC-153 ..... 160  
Figure E-2: Panel mounting ..... 161  
Figure E-3: Dimensions of panel mounting holes ..... 162  
Figure E-4: Desktop stand mounting ..... 164  
Figure E-5: Swingarm stand mounting ..... 165



# CHAPTER 1

## General Information

This chapter gives background information on the PPC-153 panel PC.

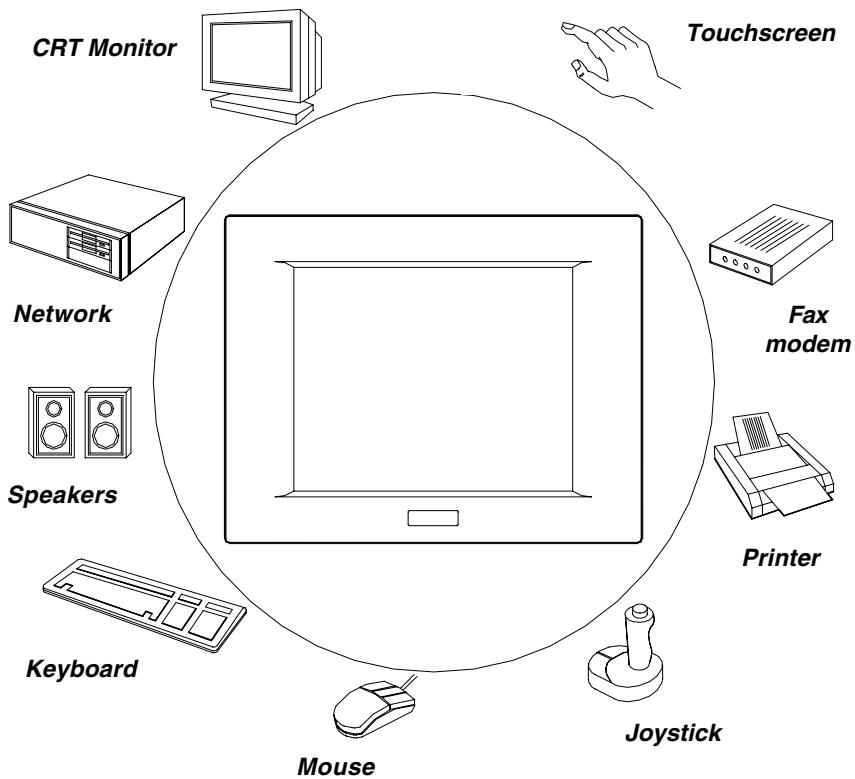
- Introduction
- How to Use This Manual
- Specifications
- Dimensions

## 1.1 Introduction

---

The PPC-153 panel PC is a multimedia Pentium®III processor-based computer that is designed to serve as a human machine interface (HMI) and as a desktop computer. It is a PC-based system with 15" color TFT LCD display, on-board PCI Ethernet controller, multi-COM port interfaces and a 16-bit stereo audio controller. With a built-in CD-ROM drive, floppy drive and PCMCIA expansion sockets, the PPC-153 is as compact and user-friendly as a notebook computer. Unlike notebook computers, the PPC-153 is more durable and versatile in all applications. The panel PC can be placed on a desktop to replace the traditional desktop computer. In addition, its "fit anywhere" design makes it very flexible and able to be used in many different kinds of installations. It can be wall mounted, panel mounted or stood upright on a desktop.

For system integrators, this simple, complete, compact and highly integrated multimedia system lets you easily build a panel PC into your applications. Common industrial applications include factory automation systems, precision machinery, and production process control. It is also suitable for many nonindustrial applications, including interactive kiosk systems, entertainment management, and car park automation. Our panel PC is a reliable, cost-effective solution to your application's processing requirements.



**Figure 1-1: The panel PC in perspective**

## 1.2 How to Use This Manual

---

This manual contains all the information you need to set up and use the panel PC. In addition to this manual, you may also want to consult the manuals for your operating system, software applications and peripherals.

Whether you are a new or an experienced user, you will benefit more from this manual if you are familiar with its organization. This manual is divided into ten chapters, plus five appendices.

**Chapter 1** (this chapter) outlines the organization of this User's Manual, provides a complete specification description of the PPC-153, and summarizes its main features.

**Chapter 2** provides step-by-step instructions to help you set up and begin using the panel PC as quickly as possible.

**Chapter 3** provides important information about the daily use of the panel PC, including using the CD-ROM drive, floppy drive and enjoying the panel PC's audio capabilities.

**Chapter 4** provides detailed step-by-step instructions to help you install the internal key components, including the CPU, hard disk drive, memory module, and so on.

**Chapter 5** provides a detailed description of jumper settings and connectors of the motherboard of the PPC-153.

**Chapter 6** explains the PCI bus Ethernet setup.

**Chapter 7** explains the AGP SVGA setup.

**Chapter 8** explains the audio setup.

**Chapter 9** explains the Award BIOS setup.

**Chapter 10** explains the PCMCIA setup.

**Chapter 11** explains how to configure and use the optional touch-screen.

**Appendix A** details the LCD specifications used in the PPC-153.

**Appendix B** explains how to program the watchdog timer.

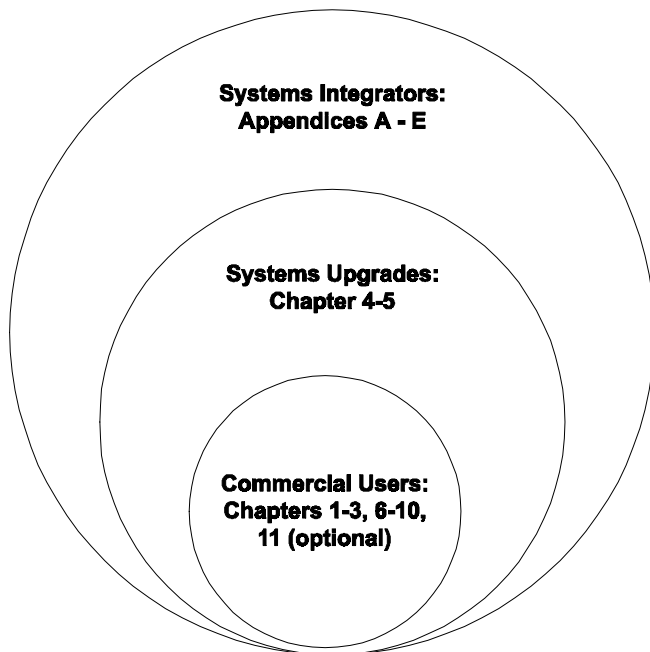
**Appendix C** includes various exploded diagrams of the PPC-153. These diagrams will help system integrators disassemble the panel PC.

**Appendix D** includes all pin assignments on the connectors.

**Appendix E** helps users install the panel PC, which is mountable in a variety of ways.

If you are a commercial user and the panel PC unit you bought is a complete set with CPU, hard disk drive, SDRAM, CD-ROM drive, floppy disk drive and PCMCIA expansion slots included, you may only need to read Chapters 1 through 3 regarding hardware operation. For additional drivers and BIOS setup information, you should read Chapters 6 through 10. If you want to upgrade your system, you may follow the instructions in Chapters 4 and 5. Chapter 11 is for users who want information about the optional touchscreen. If you are a system integrator who wants to integrate the panel PC into your system, you can refer to Appendices A through E for information such as pin assignments and how to fully disassemble the panel PC.

A suggested guide for reading this manual is shown below:



**Figure 1-2: How to read the PPC-153 manual**

## 1.3 Specifications

---

### General

- **Dimensions (W x H x D):** 420 x 323 x 106 mm (16.54" x 12.72" x 4.17")
- **Weight:** 6.5 kg (14.4 lb)
- **Power supply:**
  - AC model: 80 watts
    - Input voltage: 100~250 V<sub>AC</sub>, 3 A max. @ 50 ~ 60 Hz
    - Output voltage: +5 V @ 12 A, +12 V @ 1 A
  - DC model: 60 watts
    - Input voltage: 24 V<sub>DC</sub>, 5 A max or 12 V<sub>DC</sub>, 7 A max
    - Output voltage: +5 V @ 10 A, +12 V @ 1 A
- **Cooling fan dimensions (L x W x H):**
  - Power fan: 40 x 40 x 10 mm (1.6" x 1.6" x 0.4")
  - CPU fan: 60 x 60 x 10 mm (2.4" x 2.4" x 0.4")
- **Disk drive housing:** Space for one 2.5" HDD, one 12.7 mm compact CD-ROM drive, and one slim type 3.5" FDD
- **Front panel:**
  - IP65 protection (not for the model with SAW touchscreen)

### Standard PC functions

- **CPU:** Intel® Pentium® III and Celeron™ up to 850 MHz
- **BIOS:** Award 256 KB Flash BIOS, supports Plug & Play, APM
- **Chipset:** Intel® 82443BX / 82371EB
- **2nd level cache:** On-die 256 KB
- **RAM:**
  - One 168-pin DIMM socket accepts 32 ~ 256 MB SDRAM (3.3 V)
- **PCI bus master IDE interface:** Supports two connectors. Each connector has one channel and supports two IDE devices. Each channel supports PIO modes 0 ~ 4, DMA mode 0 ~ 2, and Ultra

DMA 33 simultaneously. The secondary connector is designated for the CD-ROM drive. BIOS supports IDE CD-ROM boot-up

- **Floppy disk drive:** Supports up to two FDDs (720 KB / 1.44 MB). One built-in FDD included inside FDD housing
- **Parallel port:** One parallel port, supports SPP/EPP/ECP parallel mode. BIOS configurable to LPT1, LPT2, LPT3 or disabled
- **Serial ports:** Four serial ports with three RS-232 ports (COM1, 3, and 4), one RS-232/422/485 port (COM2). All ports are compatible with 16C550 UARTs
- **Universal serial bus (USB) port:** Supports up to two USB ports
- **PCI/ISA bus expansion slot:**  
Accepts either one ISA card or one PCI bus card
- **Watchdog timer:** 62-level, interval 1 ~ 62 seconds. Automatically generates system reset or IRQ11 when the system stops due to a program error or EMI. Jumperless selection and software enabled/disabled
- **Battery:** 3.0 V @ 195 mA lithium battery

## Flat panel interface

- **Chipset:** Lynx3DM8 SMI721
- **Display memory:** 8 MB on-die memory
- **Display type:** Simultaneously supports CRT and flat panel displays (EL, LCD and gas plasma)
- **Display resolution:** Supports non-interlaced CRT and TFT LCD displays up to 1280 x 1024 @ 16 M colors

## Audio function

- **Chipset:** ESS 1946S
- **Audio controller:**  
16-bit codec, Full-Duplex stereo single-chip PCI audio solution

- **Stereo sound:** 100% DOS GAME compatible (Sound Blaster or Sound Blaster Pro)
- **Audio interface:**  
Microphone-in, Line-in, Line-out and Game ports (MPU-401)

### **PCI bus Ethernet interface**

- **Chipset:** Realtek RTL 8139 PCI local bus Ethernet controller
- **Ethernet interface:** Full compliance with IEEE 802.3u 100Base-T and 10 Base-T specifications. Includes software drivers and boot ROM
- **100/10Base-T auto-sensing capability**

### **PCMCIA interface**

- **Chipset:** RICOH 5C478II
- **Cardbus controller:** A PC card controller offers a single chip solution as a bridge between the PCI bus and the Cardbus
- **PCI bus interface:** Complies with PCI Local Bus Specification 2.1, and supports the 32-bit Cardbus (Card-32) and the 16-bit PC card (Card-16) without external buffers
- **Hot insertion and removal**



## Touchscreen (optional)

Type	Analog Resistive	Capacitive	Surface Acoustic Wave (SAW)
Resolution	Continuous	1024 x 1024	4096 x 4096
Light Transmission	75%	85%	91%
Controller	RS-232 interface (uses COM4)	RS-232 interface (uses COM4)	RS-232 interface (uses COM4)
Power Consumption	+5 V @ 200 mA	+5 V @ 100 mA	+5 V @ 150 mA
Software Driver	Supports DOS, Windows 3.1, Windows 95/98, Windows NT4.0		
Durability (touches in a lifetime)	30 million	20 million	50 million

*Note: The panel PC with the optionally installed touchscreen will share COM4. Once the touchscreen is installed, COM4 cannot be used for other purposes.*

## Optional modules

- **CPU:** Intel® Pentium® III and Celeron™ up to 850 MHz
- **Memory:** 32/64/128/256 MB SDRAM
- **HDD:** 2.5" HDD
- **Touchscreen:** Analog resistive, capacitive, or Surface Acoustic Wave
- **CD-ROM drive:** Compact 24X CD-ROM or above
- **DVD-ROM drive:** Compact 6X DVD-ROM or above

- **PCMCIA interface:** Complies with 1995 PCMCIA card standard. Supports two PCMCIA card/CardBus slots. Two sockets support both a 16-bit PCMCIA card and a 32-bit CardBus simultaneously. Hot insertion and removal

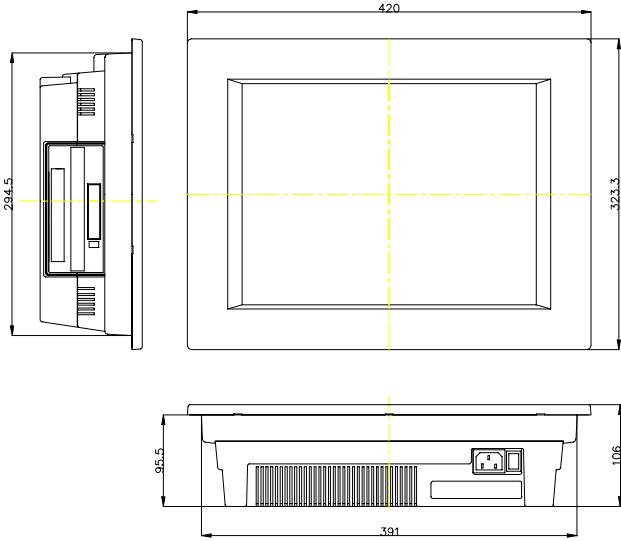
*Note 1: The PCMCIA driver of Windows 95 which includes a PCMCIA interface is available on the "Drivers and Utilities" CD-ROM of your PPC-153 package.*

## **Environment**

- **Temperature:** 0~ 45° C (32 ~ 122° F)
- **Relative humidity:** 10 ~ 95% @ 40° C (non-condensing)
- **Shock:** 10 G peak acceleration (11 msec duration)
- **Power MTBF:** 100,000 hrs
- **Certification:**
  - AC Model: EMC: CE, FCC, VCCI, BSMI approved
  - Safety: UL1950, UL2601-1, EN60950 and EN60601-1 approved
  - DC Model: FCC, UL2601-1 approved

# 1.4 Dimensions

---



*Unit: mm*

**Figure 1-3: Dimensions of the PPC-153**



# CHAPTER 2

## SYSTEM SETUP

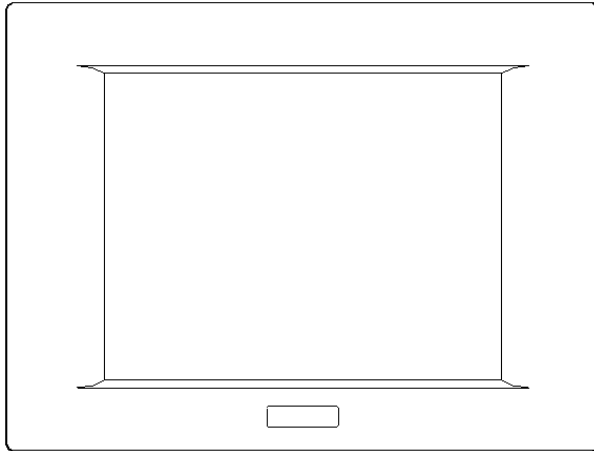
- A Quick Tour of the Panel PC
- Preparing for First-time Use
- Installation Procedures
- Running the BIOS Setup Program
- Installing System Software
- Installing the Drivers

## 2.1 A Quick Tour of the Panel PC

---

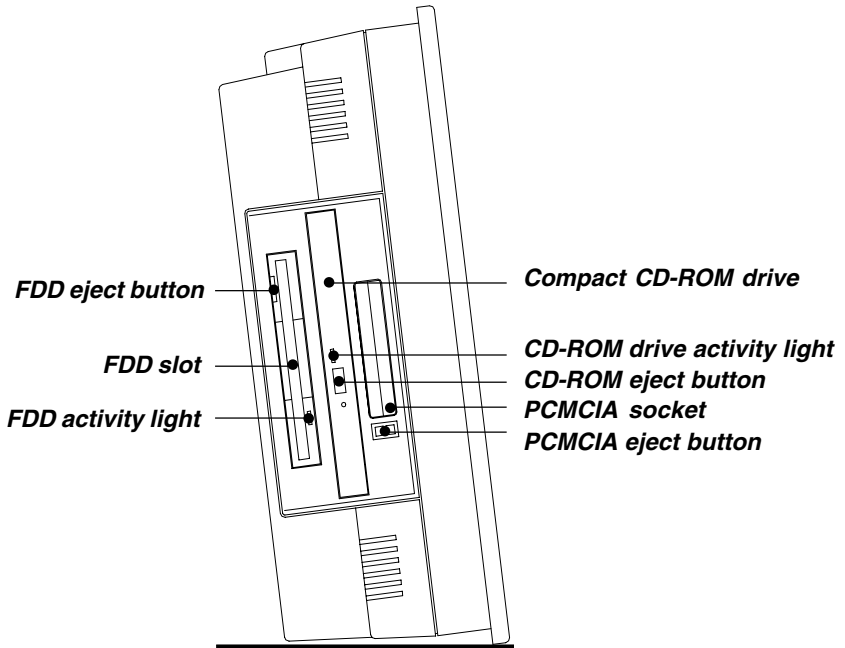
Before you start to set up the panel PC, take a moment to become familiar with the locations and purposes of the controls, drives, connectors and ports, which are illustrated in the figures below.

When you place the panel PC upright on the desktop, its front panel appears as shown in Figure 2-1.



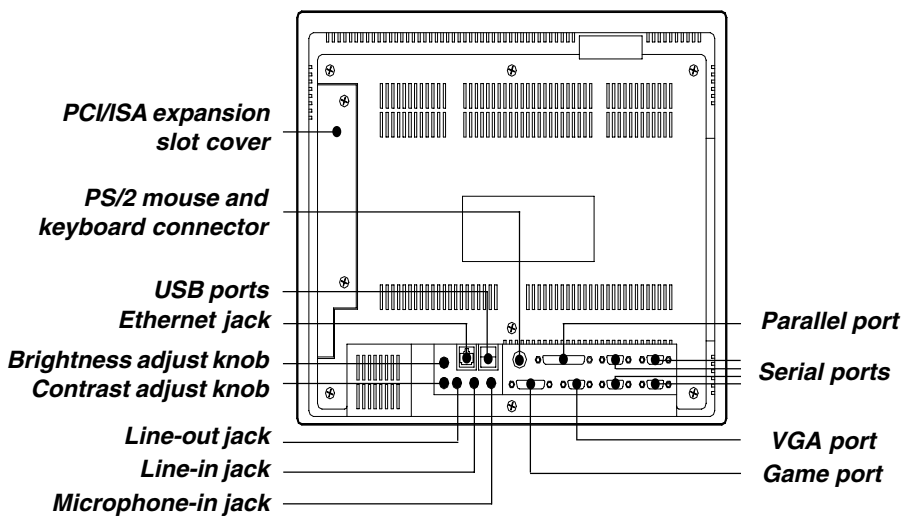
**Figure 2-1: Front view of the panel PC**

When you look at the left side of the panel PC, you will see the floppy disk drive, CD-ROM drive and PCMCIA expansion sockets, as shown in Fig. 2-2.



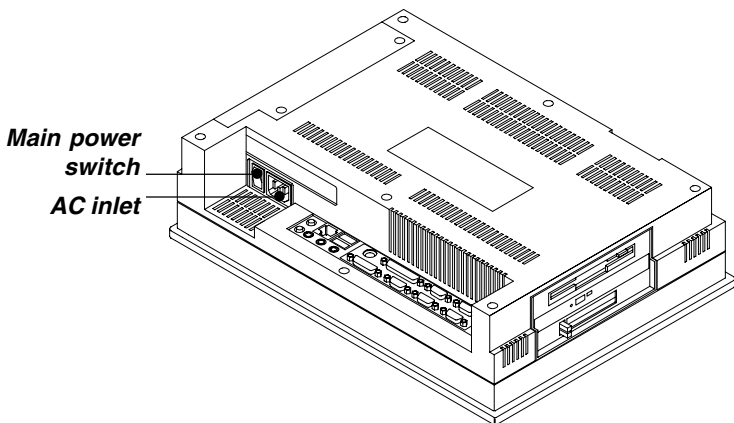
**Figure 2-2: Left side view of the panel PC**

When you turn the panel PC around and look at its rear cover, you will find the PCI/ISA expansion slot located on the left side. This slot is covered by a side panel cover. The sunken I/O section is at the bottom of the panel PC, as shown in Fig. 2-3. (The I/O section includes various I/O ports, including serial ports, parallel port, the Ethernet port, USB ports, the microphone jack, and so on.)



**Figure 2-3: Rear view of the panel PC**

Figure 2-4 shows the I/O section and power switch of the panel PC.



**Figure 2-4: Rear and side view of the panel PC**



## 2.2 Preparing For First-time Use

---

Before you start to set up the panel PC system, you should have at least the following items ready:

- Power cord (in the accessory box)
- Y-shaped connector (in the accessory box)
- Keyboard
- Mouse (for system software installation, i.e. Microsoft Windows NT, etc.)

## 2.3 Installation Procedures

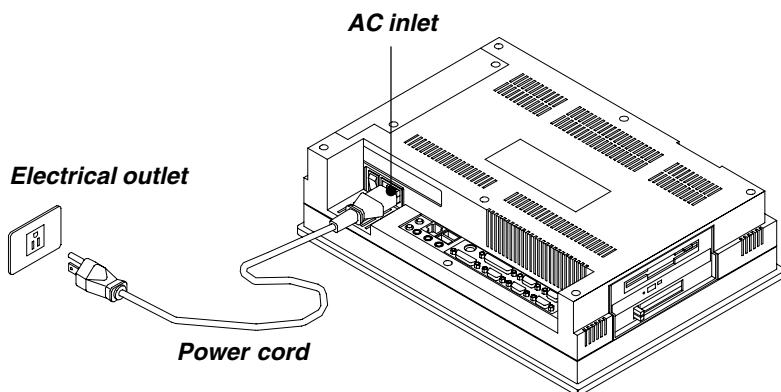
---

### 2.3.1 Connecting the power cord

The panel PC can only be powered by an AC electrical outlet (100 ~ 250 volts, 50 ~ 60 Hz). Be sure to always handle the power cords by holding the plug ends only.

Follow these procedures in order:

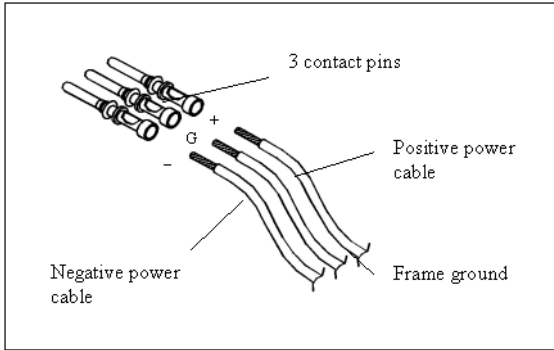
1. Connect the female end of the power cord to the AC inlet of the panel PC. (See Fig. 2-5.)
2. Connect the 3-pin male plug of the power cord to an electrical outlet.



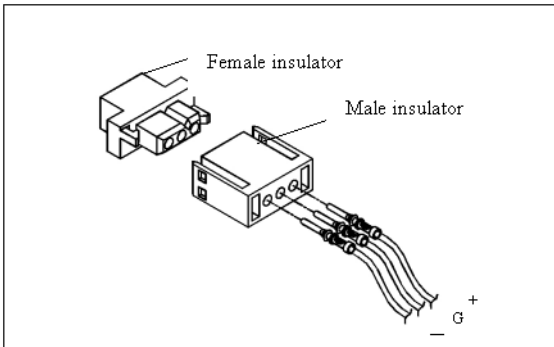
**Figure 2-5: Connecting the power cord**

### 2.3.2 Installing the DC power insulator with hood

The panel PC can also be powered by DC electrical outlet ( $24 V_{DC}$  or  $12 V_{DC}$ , which depends on the power type). Follow the procedure in order to install the DC power insulator with hood then make sure to connect the insulator with the system.

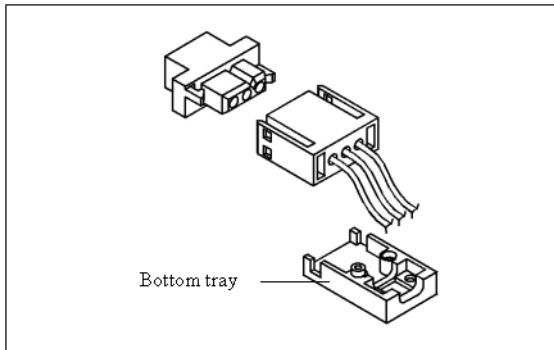


**STEP 1.** Connect the three contact pins individually to the negative and positive power cables of the power adaptor, as well as to the frame ground cable. Solder firmly.

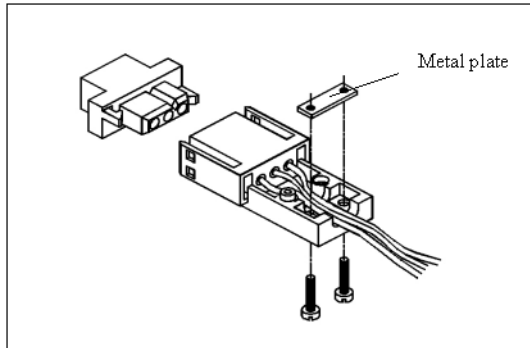


**STEP 2:** Align the soldered pins and their cables with the corresponding polarization marks on the front part of the male insulator (+ / G / -). Now plug the pins separately into the holes of the male insulator. Pin 1

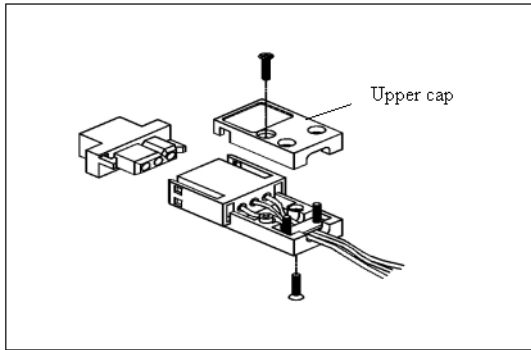
Now plug the pins separately into the holes of the male insulator. Pin 1 should go into the positive DC power input ( + ), pin 2 connects to the frame ground ( G ), and pin 3 should be plugged into the negative DC power input ( - ).



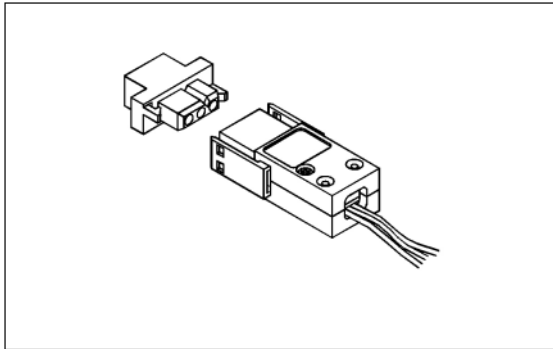
**STEP 3:** Mount the front part of the male insulator onto the bottom tray.



**STEP 4:** Use the metal plate and the two screws to secure the cables to the bottom tray. Please refer to the illustration above.



**STEP 5:** Attach the upper cap to the bottom tray and secure it with the screws.

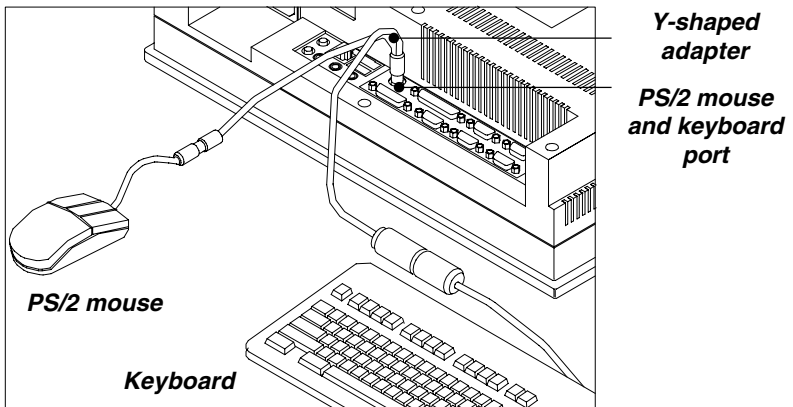


**STEP 6:** Now that you have completed the assembly of the male insulator, plug it into the female insulator.

### 2.3.3 Connecting the keyboard and mouse

1. Connect the Y-shaped adapter to the PS/2 mouse and keyboard port on the I/O section of the panel PC. (See Fig. 2-6.)
2. Connect the PS/2 mouse and keyboard to the Y-shaped adapter. (See Fig. 2-6.)

If you use a serial mouse and your panel PC has a touchscreen, you can connect the mouse to any COM port except COM4.



**Figure 2-6: Connecting the keyboard and mouse**

### 2.3.4 Switching on the power

Switch on the power switch on the rear cover. (See Fig. 2-4.)

## 2.4 Running the BIOS Setup Program

---

Your panel PC is likely to have been properly set up and configured by your dealer prior to delivery. You may still find it necessary to use the panel PC's BIOS (Basic Input-Output System) setup program to change system configuration information, such as the current date and time or your type of hard drive. The setup program is stored in read-only memory (ROM). It can be accessed either when you turn on or reset the panel PC, by pressing the "Del" key on your keyboard immediately after powering on the computer.

The settings you specify with the setup program are recorded in a special area of memory called CMOS RAM. This memory is backed up by a battery so that it will not be erased when you turn off or reset the system. Whenever you turn on the power, the system reads the settings stored in CMOS RAM and compares them to the equipment check conducted during the power on self-test (POST). If an error occurs, an error message will be displayed on screen, and you will be prompted to run the setup program.

If you want to change the setup of BIOS, refer to Chapter 9 for more detailed information.

## 2.5 Installing System Software

---

Recent releases of operating systems from major vendors include setup programs which load automatically and guide you through hard disk preparation and operating system installation. The guidelines below will help you determine the steps necessary to install your operating system on the panel PC hard drive.

*Note: Some distributors and system integrators may have already pre-installed system software prior to shipment of your panel PC.*

If required, insert your operating system's installation or setup diskette into the diskette drive until the release button pops out. (See Fig. 3-1.)

The BIOS of the panel PC supports system boot-up directly from the CD-ROM drive. You may also insert your system installation CD-ROM into the CD-ROM drive. (See Fig. 3-2.) Refer to Chapter 9 if you wish to change the BIOS settings.

Power on your panel PC or reset the system by pressing the "Ctrl"+"Alt"+"Del" keys simultaneously. The panel PC will automatically load the operating system from the diskette or CD-ROM.

If you are presented with the opening screen of a setup or installation program, follow the instructions on screen. The setup program will guide you through preparation of your hard drive, and installation of the operating system.

If you are presented with an operating system command prompt, such as A:\>, then you must partition and format your hard drive, and manually copy the operating system files to it. Refer to your operating system user's manual for instructions on partitioning and formatting a hard drive.

## 2.6 Installing the Drivers

---

After installing your system software, you will be able to set up the Ethernet, SVGA, audio, PCMCIA and touchscreen functions. All the drivers except the CD-ROM drive driver are stored in a CD-ROM disc entitled "Drivers and Utilities." The CD-ROM drive driver is stored in a floppy disk. Both the CD-ROM and the floppy disk can be found in your accessory box.

To set up the CD-ROM function, insert the floppy disk with the CD-ROM drive driver into the floppy disk drive and type "install" after the following prompt is displayed on screen:

A: > INSTALL

Press "Enter", and the installation process will be completed in a few seconds.

The standard procedures for installing the Ethernet, SVGA, audio, PCMCIA and touchscreen drivers are described in Chapters 6, 7, 8, 10 and 11 respectively.

For your reference, the directory of drivers on the "Drivers and Utilities" CD-ROM is:

```
D: ─── Audio (drivers)
    ─── Document (manuals)
    ─── Elotouch (drivers)
    ─── LAN (Ethernet drivers)
    ─── Microtouch (drivers)
    ─── Utility
    ─── VGA (drivers)
    ─── Cardbus (drivers)
```

The utility directory includes multimedia programs. Refer to the README.TXT file inside the VGA folders for more detailed information.



The various drivers and utilities in the CD-ROM disc have their own text files which help users install the drivers and understand their functions. These files are a very useful supplement to the information in this manual.

*Note: The drivers and utilities used for the PPC-153 panel PCs are subject to change without notice. If in doubt, check Advantech's website or contact our application engineers for the latest information regarding drivers and utilities.*



# CHAPTER 3

## Using the Panel PC

- Introduction
- Floppy Drive
- CD-ROM Drive
- PCMCIA
- PS/2 Mouse and Keyboard
- PCI/ISA Bus Expansion
- Parallel Port
- Serial COM Ports
- VGA Port
- Game Port
- USB Ports
- Audio Interface
- Ethernet
- Adjusting the LCD Contrast and Brightness
- Touchscreen (Optional)

## 3.1 Introduction

---

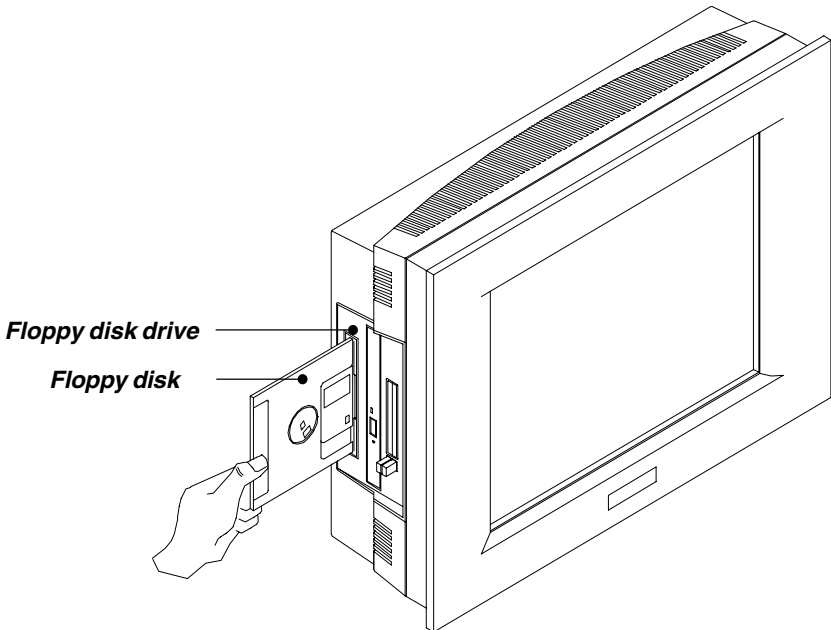
This chapter describes basic features and procedures for using the panel PC. Topics covered include the floppy drive, CD-ROM drive, I/O ports, touchscreen, and so on.

## 3.2 Floppy Drive

---

To insert a floppy disk, hold it with your left hand, between your thumb and your other fingers, and push it toward the drive. (See Fig. 3-1.) Slide the disk until it clicks into place. Note that new disks must be formatted by your operating system before you can use them for data storage. See your operating system manual for details.

To eject a floppy disk, first make sure that the drive activity light is off, and then press the eject button on the drive. When the disk pops out of the drive, remove it and store it properly.



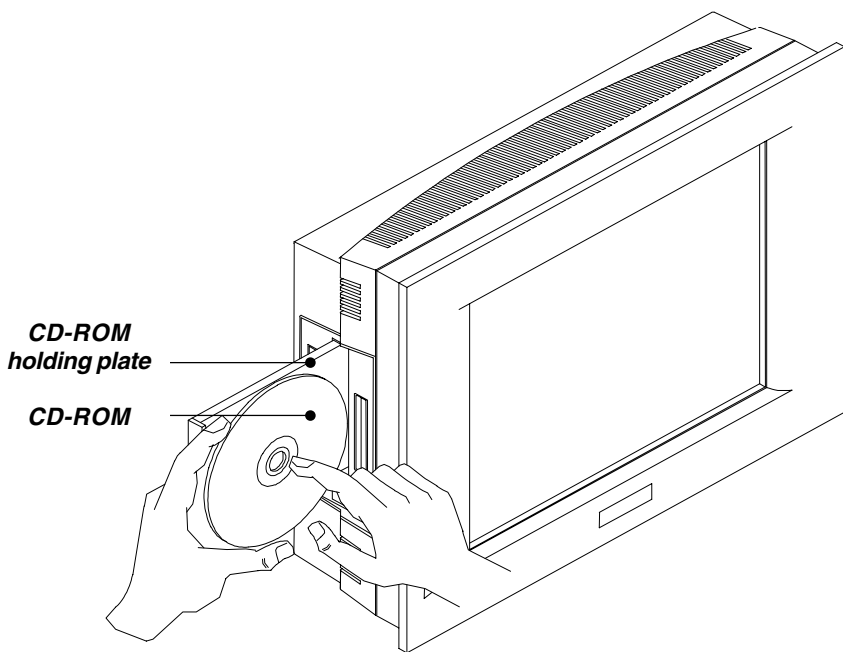
**Figure 3-1: Inserting and ejecting a floppy disk**

### 3.3 CD-ROM Drive

---

To insert a CD-ROM disc, press the eject button of the CD-ROM drive. The yellow activity light will flash and the front panel will come out a short distance. Using your fingertips, hold the top and bottom of the front panel and pull it outward to the very end. (See Fig 3-2.) Align the center hole of the CD-ROM disc with the center circle of the CD-ROM holding plate. Press the transparent ring around the center hole of the CD-ROM until you hear a click. Push the front panel of the CD-ROM drive back to its original place.

To eject a CD-ROM disc, first ensure that the drive activity light is off. Then press the eject button on the drive. When the disc pops out of the drive, remove it and store it properly.



**Figure 3-2: Inserting and ejecting a CD-ROM disc**

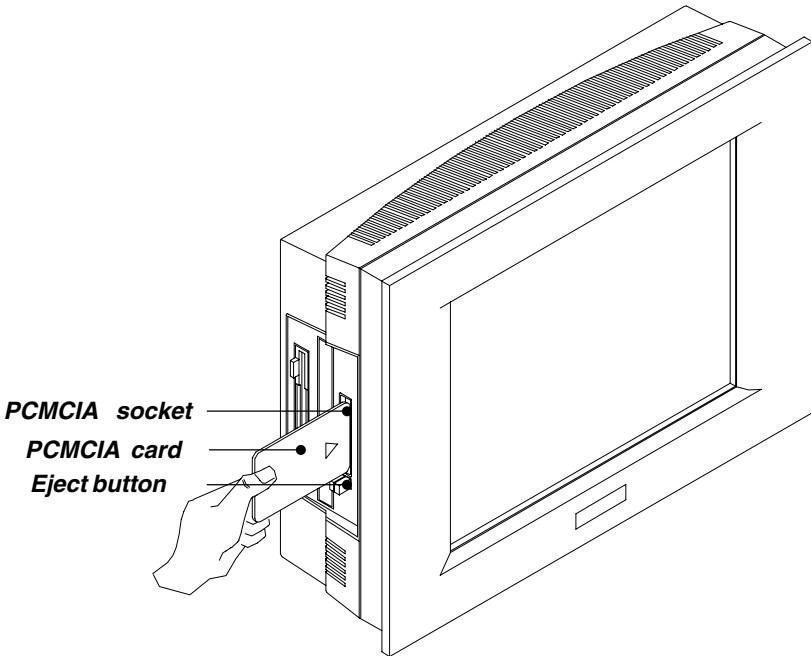
## 3.4 PCMCIA

---

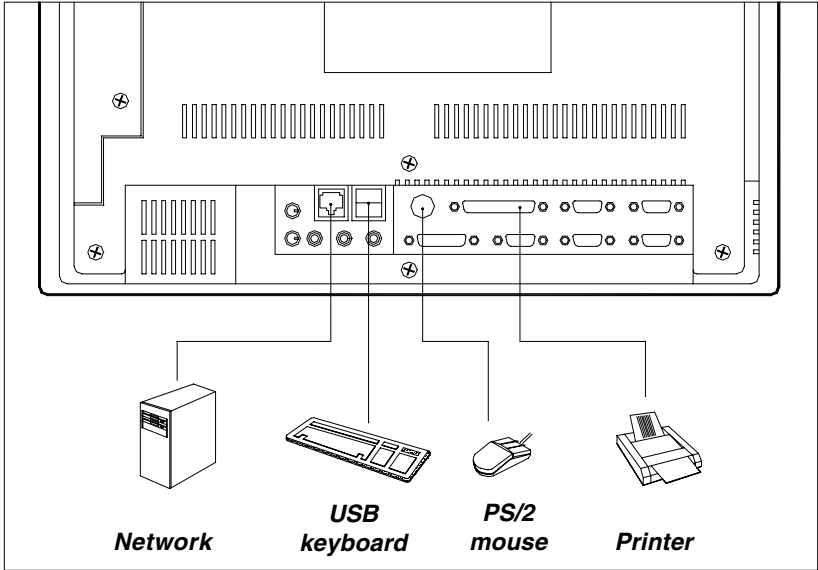
PCMCIA cards are inserted and ejected in much the same way as diskettes.

To insert a PCMCIA card, align the card with the socket and slide the card into the socket until it locks into place. Note that some PCMCIA memory cards must be prepared by your operating system before you can use them for data storage. See your PCMCIA card manual for details.

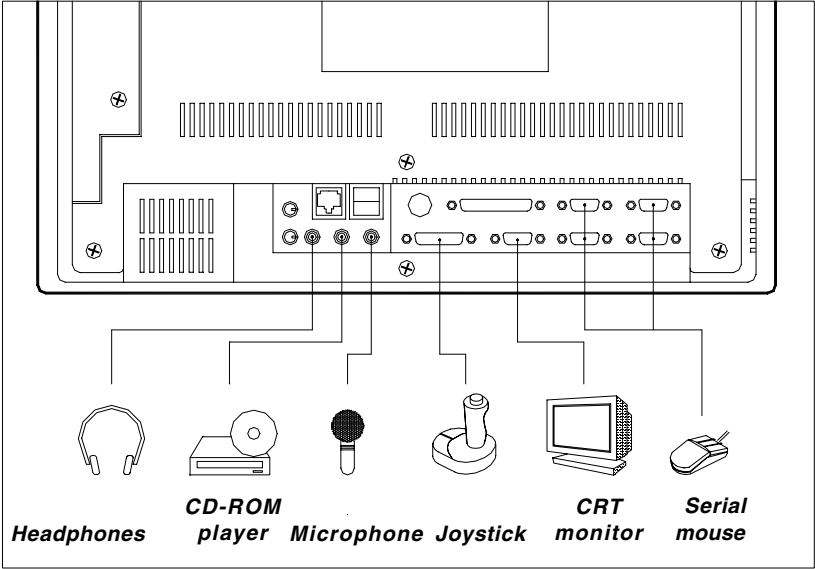
To eject a PCMCIA card, first ensure that the panel PC is not accessing the memory card or device. Then press the appropriate eject button on the socket. When the card pops out of the socket, remove it and store it properly.



**Figure 3-3: Inserting and ejecting a PCMCIA card**



**Figure 3-4: Using the I/O interface (upper level ports excluding COM ports)**



**Figure 3-5: Using the I/O interface (lower level ports and COM ports)**



## 3.5 PS/2 Mouse and Keyboard

---

If you wish to use a full-size desktop keyboard and PS/2 mouse with your panel PC, follow these instructions:

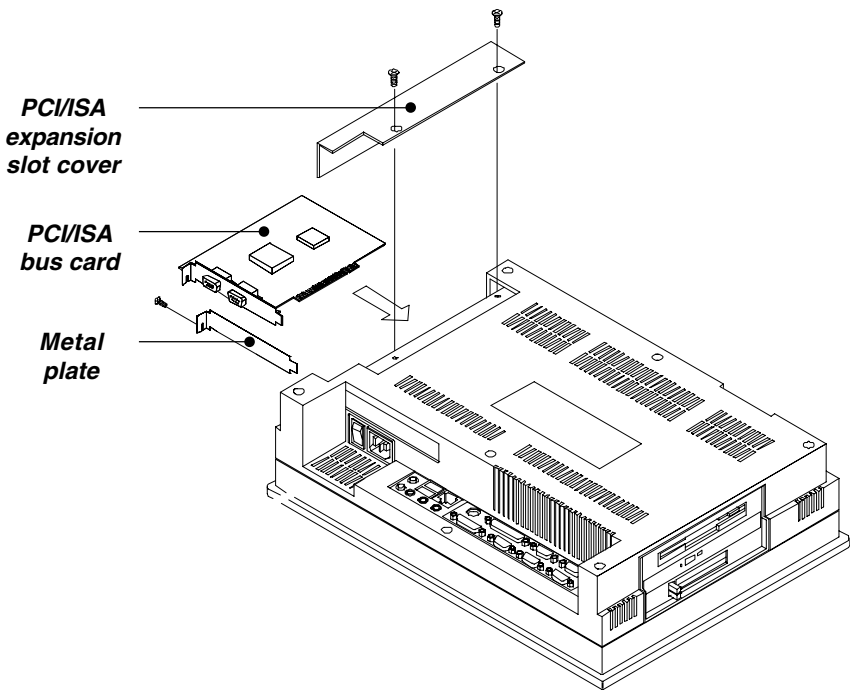
1. Be sure the panel PC is turned off.
2. Connect the Y-shaped adapter to the PS/2 mouse and keyboard port on the rear bottom side of the rear cover. (See Fig. 3-4 and Fig. 2-6.)
3. Attach the keyboard to the 5-pin port of the Y-shaped adapter.
4. Attach the PS/2 mouse to the 6-pin female PS/2 port of the Y-shaped adapter.
5. Turn on the panel PC.

## 3.6 PCI/ISA Bus Expansion

---

The panel PC supports PCI and ISA bus expansion cards. To integrate a new PCI or ISA bus card into your system, follow these instructions:

1. Turn off the panel PC.
2. Unscrew the two screws on the top of the PCI/ISA bus expansion slot cover, and remove this cover.
3. Remove the metal plate by unscrewing the single attaching screw.
4. Insert the PCI or ISA bus card into the PCI/ISA slot of the riser card. (See Fig. 3-6 overleaf.)
5. Run the setup program within your operating system to configure your system.



**Figure 3-6: PCI/ISA bus expansion**

## 3.7 Parallel Port

---

The panel PC supports the latest EPP and ECP parallel port protocols for improved performance and versatility with compatible printers or other devices.

To connect the panel PC to a printer or other devices:

1. Be sure both the panel PC and the printer/devices are turned off.
2. Connect the 25-pin male connector of the printer cable to the 25-pin female port on the panel PC labelled "parallel port".
3. If necessary, attach the other end of your printer cable to your printer, and fasten any retaining screws. A typical parallel printer connection is illustrated in Fig. 3-4.
4. Turn on the printer and any other peripheral devices you may have connected to the panel PC, and then turn on the panel PC.
5. If necessary, run the panel PC's BIOS setup program to configure the parallel port to respond as required by your printer and software operating environment.

## 3.8 Serial COM Ports

---

There are four serial COM ports on the bottom of the rear cover. You can easily attach a serial device to the panel PC, such as an external modem or mouse. Follow these instructions:

1. Be sure the panel PC and any other peripheral devices you may have connected to the panel PC are turned off.
2. Attach the interface cable of the serial device to the panel PC's serial port. (See Fig. 3-5.) If necessary, attach the other end of the interface cable to your serial device. Fasten any retaining screws.
3. Turn on any other peripheral devices you may have connected to the panel PC, and then turn on the panel PC.
4. Refer to the manual(s) which accompanied your serial device(s) for instructions on configuring your operating environment to recognize the device(s).
5. Run the BIOS setup program and configure the jumper settings to change the mode of the COM ports. (See Section 5.3.)

## 3.9 VGA Port

---

An external VGA-compatible device may be connected to the system through the 15-pin external port located on the rear of the system unit. The panel PC simultaneously supports an external CRT monitor in addition to its own LCD display.

1. Be sure the panel PC is turned off.
2. Connect the external monitor to the system. (See Fig. 3-5.)
3. Turn on the panel PC and the external monitor.

## 3.10 Game Port

---

An external game device may be connected to the system through the 15-pin external port located on the rear of the system unit.

1. Be sure the panel PC is turned off.
2. Connect the external joystick or game device to the system. (See Fig. 3-5.)
3. Turn on the panel PC and the external joystick or game device (if applicable).
4. Install the driver before you use the joystick or game device.

## 3.11 USB Ports

---

An external USB device may be connected to the system through the 4-pin USB ports located on the rear side of the system unit.

1. Connect the external device to the system. (See Fig. 3-4.)
2. The USB ports support hot plug-in connection. You should install the device driver before you use the device.

## 3.12 Audio Interface

---

The audio interface includes three jacks: microphone in, line out and line in. (See Fig. 3-5.) Their functions are:

**Microphone in:** Use an external microphone to record voice and sound.

**Line out:** Output audio to external devices such as speakers or earphones.

**Line in:** Input audio from an external CD player or radio.

1. Connect the audio device to the system. (See Fig. 3-5.)
2. Install the driver before you use the device.

## 3.13 Ethernet

---

External devices on your network may be connected to the system through the external ethernet port located on the rear side of the system unit.

1. Be sure the panel PC is turned off.
2. Connect the external device(s) to the panel PC. (See Fig. 3-4.)
3. Turn on the panel PC and the external device(s).
4. Under DOS, run the RSET8139 program to check the hardware network status before installing the Ethernet driver.
5. Run the Ethernet driver to connect up to the network.

## 3.14 Adjusting the LCD Contrast and Brightness

---

The contrast control knob does not function because the PPC-153 includes the TFT LCD display. Only panel PCs with DSTN LCD displays have this function.

The brightness control knob allows you to adjust the brightness of the LCD display panel.

## 3.15 Touchscreen (Optional)

---

The touchscreen is connected to COM4. Its function is similar to that of a mouse. The only difference is that you put your fingertip on the screen to move the cursor.

You will need to install the touchscreen driver before it will work. The touchscreen drivers for various operating systems are stored on the CD-ROM disc inside the accessory box. The touchscreen manual can also be found on this disc. Read Chapter 11 of this manual carefully before you install the driver.

# CHAPTER 4

## Hardware Installation and Upgrading

- Overview of Hardware Installation and Upgrading
- Disassembling the Panel PC
- Installing the 2.5" Hard Disk Drive (HDD)
- Installing the Central Processing Unit (CPU)
- Installing the SDRAM Memory Module
- Installing the Floppy Disk Drive (FDD) and Slim CD-ROM Drive

## 4.1 Overview of Hardware Installation and Upgrading

---

The panel PC consists of a PC-based computer that is housed in a plastic rear panel and a metal shielding case. Your HDD, SDRAM, power supply, CPU, and so on are all readily accessible by removing the rear panel and shielding case. Any maintenance or hardware upgrades can be easily completed after removing the rear panel and shielding case.

If you are a systems integrator and need to know how to completely disassemble the panel PC, you can find more useful information in Appendix C.

**Warning!** *Do not remove the plastic rear cover until you have verified that no power is flowing within the panel PC. Power must be switched off and the power cord must be unplugged. Every time you service the panel PC, you should be aware of this.*



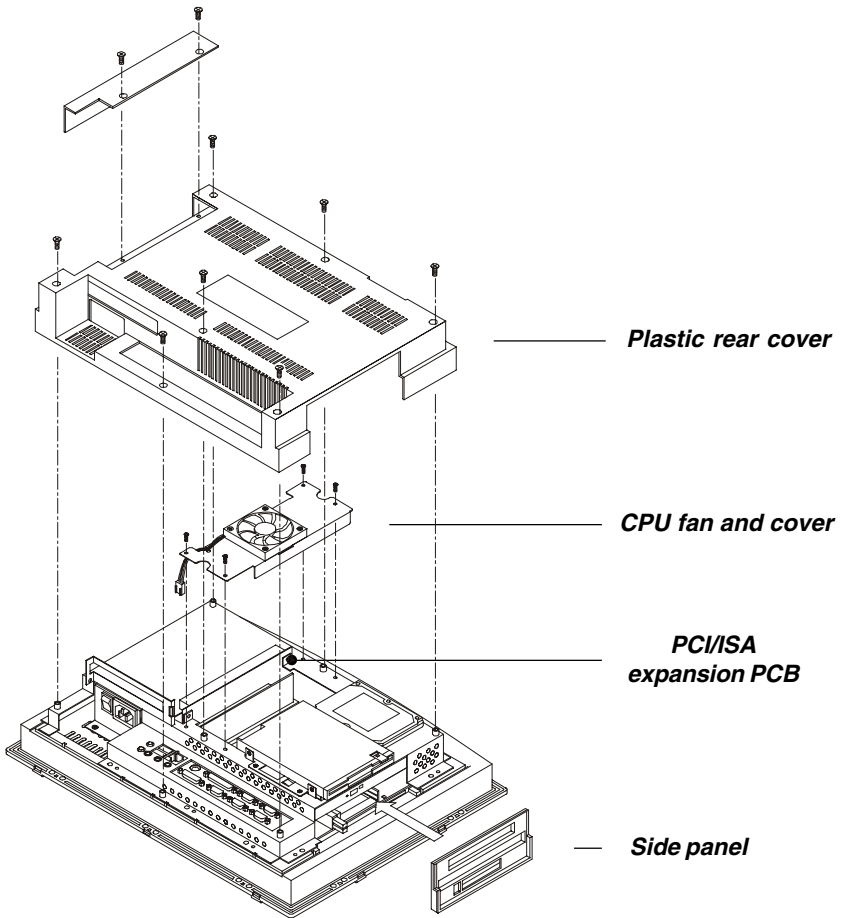
## 4.2 Disassembling the Panel PC

---

The following are standard procedures for disassembling the panel PC before you upgrade your system. All procedures are illustrated in Fig. 4-1.

1. Unscrew the seven screws that secure the plastic rear cover, and then remove the cover.
2. Unscrew the two screws of the PCI/ISA expansion PCB, and remove it.
3. Unscrew the four screws that secure the CPU cover.
4. Remove the floppy drive, HDD, and CD-ROM cables; then remove the side panel.
5. Unscrew the ten screws of the shielding case, and remove it.



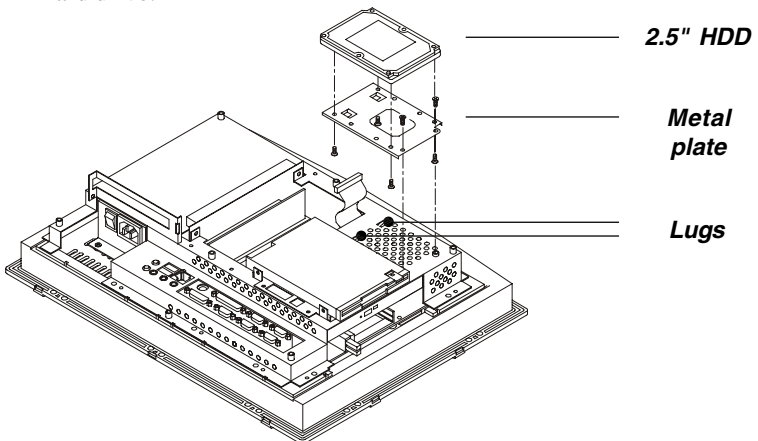


**Figure 4-1: Disassembling the plastic rear cover of the panel PC**

## 4.3 Installing the 2.5" Hard Disk Drive (HDD)

You can attach one enhanced Integrated Device Electronics (IDE) hard disk drive to the panel PC's internal controller which uses a PCI local-bus interface. The advanced IDE controller supports faster data transfer and allows the IDE hard drive to exceed 528 MB. The following are instructions for installation:

1. Detach and remove the plastic rear cover and side panel.
2. There is a metal plate which holds the HDD to the upper right-hand side of the metal shielding case. (See Fig. 4-2.) Remove the two screws on the metal plate.
3. Pull the metal plate toward the outside of the unit, and remove it from the two lugs of the shielding case.
4. Place the HDD on the metal plate, and tighten the four screws from the bottom of the metal plate.
5. The HDD cable (1 x 44-pin to 1 x 44-pin) is next to the metal plate. Connect the HDD cable to the HDD. The another end of the HDD cable is connected to the PC board (CN16). Make sure that the red/blue wire corresponds to Pin 1 on the connector, which is labeled on the board. Plug the other end of the cable into the IDE hard drive, with Pin 1 on the cable corresponding to Pin 1 on the hard drive.



**Figure 4-2: Installing the primary 2.5" HDD**

## 4.4 Installing the Central Processing Unit (CPU)

---

The panel PC's central processing unit (CPU) can be upgraded to improve system performance. The panel PC provides one 370-pin ZIF (Zero Insertion Force) socket (Socket 370). The CPU must come with an attached heat sink and CPU fan to prevent overheating.

**Warning!** *The CPU may be damaged if operated without a heat sink and a fan.*



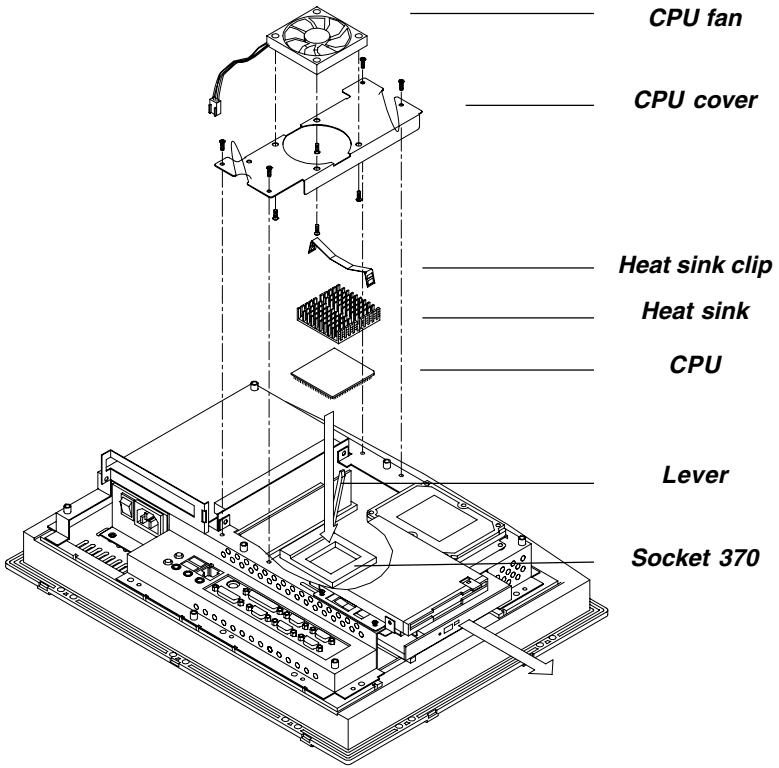
**Caution!** *Always disconnect the power cord from your panel PC when you are working on it. Do not make connections while the power is on as sensitive electronic components can be damaged by the sudden rush of power. Only experienced electronics personnel should open the panel PC.*



1. Detach and remove the plastic rear cover.
2. Remove the four screws of the CPU cover, and remove the cover.
3. Detach the CPU fan power cable from the CPU fan.
4. There is a metal plate which holds the FDD and slim CD-ROM drive to the metal shielding case. There are two screws ("A") on this metal plate. Loosen these two screws.
5. Remove the plastic side cover of the FDD.
6. Push the FDD and slim CD-ROM drive toward the outside of the panel PC, as far as they will go. This will expose the entire CPU assembly underneath.
7. Locate the ZIF socket and open it by first pulling the lever side-ways away from the socket, then upwards at an angle of 90 degrees.

8. Insert the CPU with the correct orientation. The notched corner of the CPU (with the white dot) should point towards the end of the lever. The end of the lever is the blank area where one hole is missing from the corner of the square array of pin holes. An arrowhead printed on the motherboard points to the end of the lever. (See Fig. 4-3 overleaf.)
9. Slide the CPU in gently. It should insert easily. If not, pull the lever up a little more and make sure the pins of the CPU correspond with the holes of the socket. **DO NOT USE EXCESSIVE FORCE!**
10. Press the lever down. The plate will slide across slightly.
11. Place the heat sink on top of the CPU and fasten it with the heat sink clip (shown in Fig. 4-3).
12. Move the FDD and slim CD-ROM drive back to their original position.
13. Put back the plastic side cover of the FDD.
14. Tighten the two screws ("A") on the metal plate.
15. Connect the CPU fan power cable to the 3-pin connector (FAN1).
16. Put back the CPU cover, and secure the four screws on it.

*Note:*        *To remove the CPU, follow steps 1 through 7 above. You should then be able to freely lift out the CPU chip.*



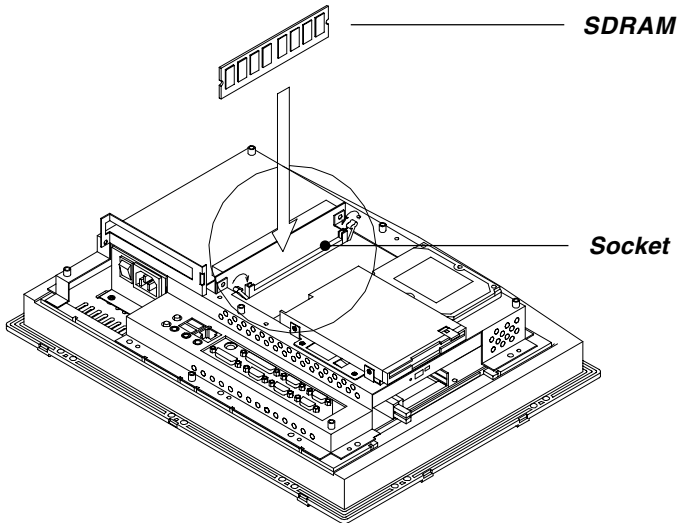
**Figure 4-3: Installing the CPU**

## 4.5 Installing the SDRAM Memory Module

You can install from 32 to 256 MB of SDRAM memory. The panel PC system provides one 168-pin DIMM (Dual Inline Memory Module) socket and supports 3.3 V SDRAM with a minimum speed of 12 ns.

*Note:* The module can fit into the socket only one way. Pin 1 of the DIMM module must line up with the small arrowhead printed on the motherboard next to the DIMM socket. The golden pins of the module must point down into the DIMM socket.

1. Detach and remove the plastic rear cover and CPU cover.
2. Push the two white eject levers on each side of the DIMM outward until they are separated from the black vertical posts. (See Fig. 4-4.)
3. Insert the memory module into the socket at an angle of 90 degrees.
4. Push the two eject levers toward the vertical posts at each end of the socket until the module is upright.



**Figure 4-4: Installing SDRAM**

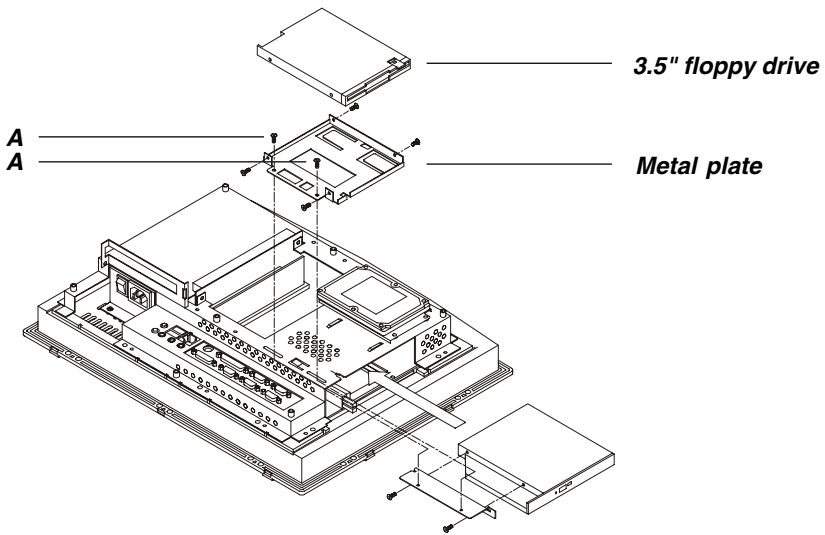
## 4.6 Installing the Floppy Disk Drive (FDD) and Slim CD-ROM Drive

---

Installation of a floppy disk drive and slim CD-ROM drive is similar to that for a hard disk drive. The metal plate for holding the FDD and the CD-ROM support bracket are on the left side of the shielding case. The 26-pin and 40-pin yellow FPC cables are for connecting the FDD and CD-ROM respectively. Only 3.5" floppy disk drives (720 KB and 1.44 MB) and slim CD-ROM drives can be attached to the metal plate and CD-ROM support bracket.

1. Detach and remove the plastic rear cover and side panel.
2. There is a metal plate which holds the FDD and slim CD-ROM drive to the metal shielding case. There is also a slim CD-ROM support bracket which is attached to the shielding case. There are two screws ("A") on the metal plate. Unscrew these two screws. (See Fig. 4-5.)
3. Push the metal plate toward the outside of the unit. This will free it from the two lugs of the shielding case.
4. Slide the CD-ROM support bracket toward the outside of the panel PC, and remove it.
5. Place the FDD on the metal plate. There are four small screws, two on each side of the metal plate. Tighten these screws.
6. Place the support bracket against the slim CD-ROM drive. It should fit neatly into the space allocated for the bracket. (See Fig. 4-5.)
7. Attach the support bracket to the slim CD-ROM drive by tightening the two small screws located in the bracket.
8. Insert the FDD assembly into the shielding case. Then insert the slim CD-ROM drive assembly into the shielding case. Make sure that the hooked lug on the slim CD-ROM drive assembly engages into the corresponding slot of the combined FDD assembly and shielding case.

9. Connect the FDD cable (26-pin to 26-pin) and CD-ROM cable (40-pin to 40-pin). The other end of the FDD cable is connected to connector CN10 on the PC board. The other end of the CD-ROM cable is connected to connector CN18 on the PC board.
10. Slide the FDD assembly and slim CD-ROM assembly toward the inside of the panel PC, as far as they will go.
11. Secure the two screws ("A") of the metal plate to the shielding case.



**Figure 4-5: Installing the FDD and slim CD-ROM drive**



# CHAPTER 5

## Jumper Settings and Connectors

This chapter tells how to set up the panel PC hardware, including instructions on setting jumpers and connecting peripherals, switches and indicators. Be sure to read all the safety precautions before you begin the installation procedures.

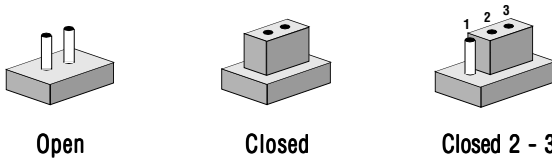
- Jumpers and Connectors
- CPU Installation
- CMOS Clear for External RTC (JP8)
- COM-port Interface
- Internal -12 V Source Selection Setting (JP1)
- VGA Interface
- Watchdog Timer Configuration

# 5.1 Jumpers and Connectors

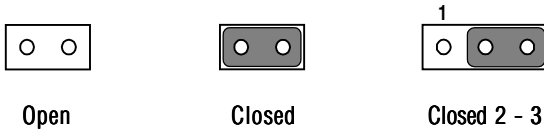
---

## 5.1.1 Setting jumpers

You can configure your panel PC to match the needs of your application by setting jumpers. A jumper is the simplest kind of electrical switch. It consists of two metal pins and a small metal clip (often protected by a plastic cover) that slides over the pins to connect them. To “close” a jumper, you connect the pins with the clip. To “open” a jumper you remove the clip. Sometimes a jumper will have three pins, labeled 1, 2, and 3. In this case, you would connect either pins 1 and 2 or pins 2 and 3.



The jumper settings are schematically depicted in this manual as follows:



A pair of needle-nose pliers may be helpful when working with jumpers.

If you have any doubts about the best hardware configuration for your application, contact your local distributor or sales representative before you make any changes.

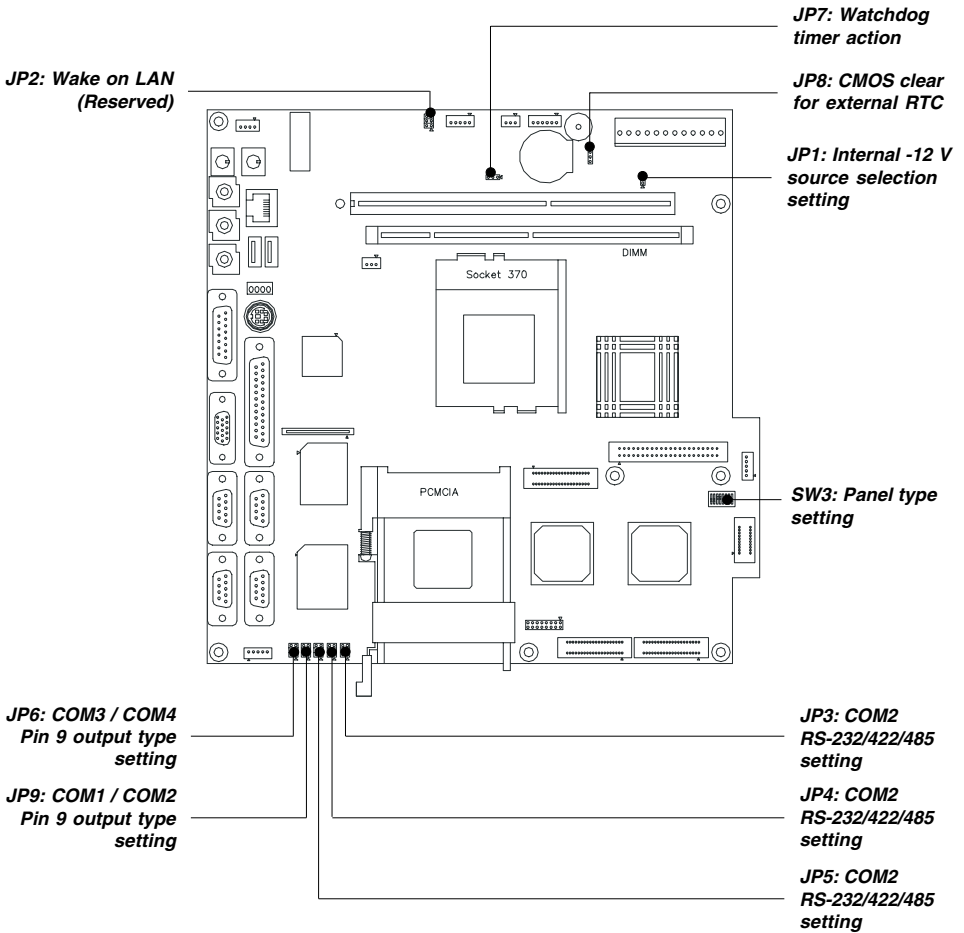
## 5.1.2 Jumpers and switch

The motherboard of the panel PC has a number of jumpers that allow you to configure your system to suit your applications. The table below lists the function of each of the board's jumpers.

Table 5-1: Jumpers and their functions

<b>Label</b>	<b>Function</b>
JP1	Internal -12 V source selection setting
JP2	Wake on LAN (Reserved)
JP3	COM2 RS-232/422/485 setting
JP4	COM2 RS-232/422/485 setting
JP5	COM2 RS-232/422/485 setting
JP6	COM3 / COM4 Pin 9 output type setting
JP7	Watchdog timer action
JP8	CMOS clear for external RTC
JP9	COM1 / COM2 Pin 9 output type setting
SW3	Panel type setting

## 5.1.3 Locating jumpers and switch



**Figure 5-1: Locating jumpers on the PPC-153 motherboard**

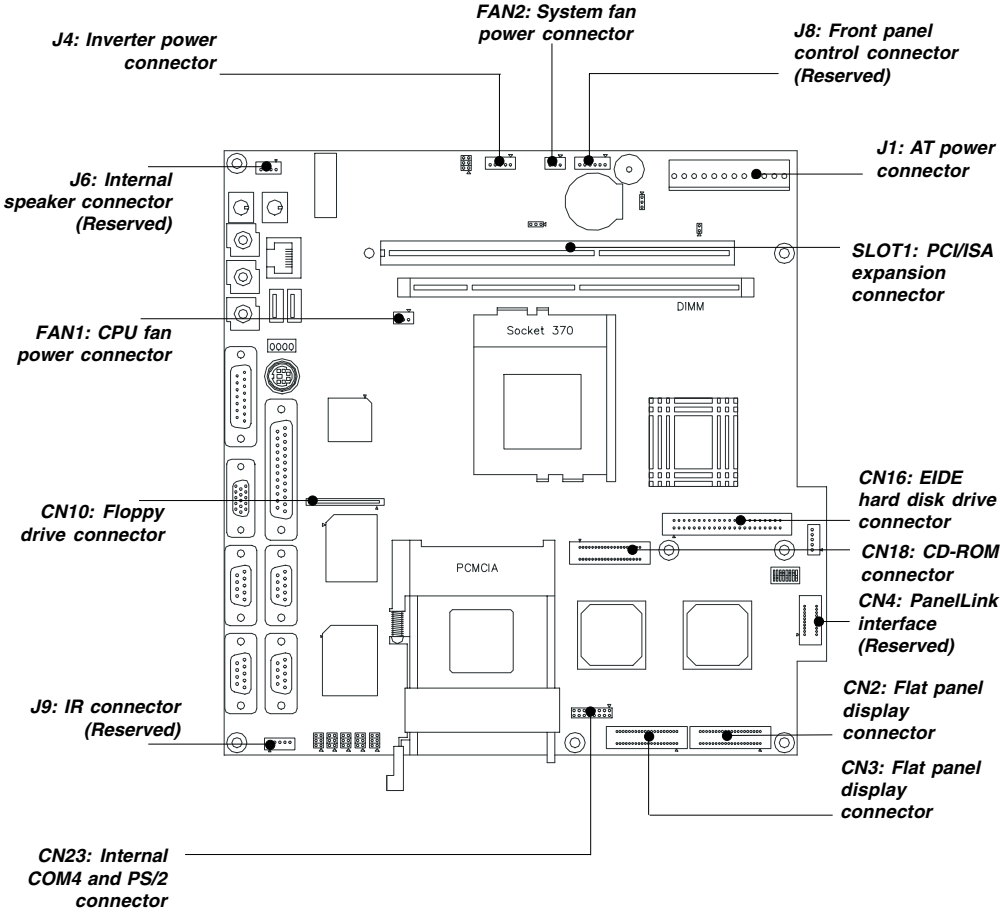
## 5.1.4 Connectors

Onboard connectors link the panel PC to external devices such as hard disk drives or floppy drives. The table below lists the function of each of the board's connectors.

Table 5-2: Panel PC connectors

<b>Label</b>	<b>Function</b>
J1	AT power connector
J4	Inverter power connector
J6	Internal speaker connector (Reserved)
J8	Front panel control connector (Reserved)
J9	IR connector (Reserved)
CN2	Flat panel display connector
CN3	Flat panel display connector
CN4	PanelLink interface (Reserved)
CN10	FDD connector
CN16	EIDE hard disk drive connector
CN18	CD-ROM connector
CN23	Internal COM4 and PS/2 connector
FAN1	CPU fan power connector
FAN2	System fan power connector
SLOT1	PCI/ISA bus expansion connector

## 5.1.5 Locating connectors



**Figure 5-2: Locating connectors on the PPC-153 motherboard**

## 5.2 CPU Installation

---

You can install an Intel® Pentium® III or Celeron™ CPU without setting any frequency ratio or voltage.

## 5.3 CMOS Clear for External RTC (JP8)

---

**Warning:** To avoid damaging the computer, always turn off the power supply before setting “Clear CMOS”. Set the jumper back to “Normal operation” before turning on the power supply.

---

Table 5-3: Clear CMOS / External RTC (JP8)

---

**\*Normal operation**



**Clear CMOS**



---

\* default setting

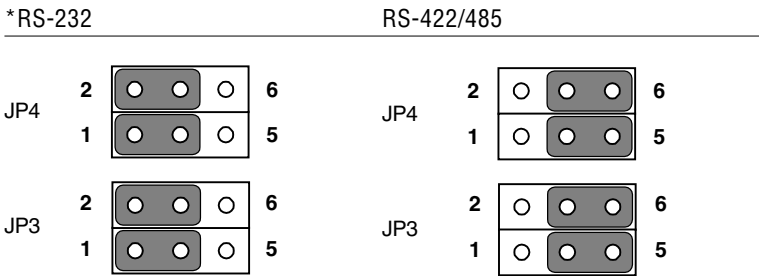
# 5.4 COM-port Interface

The panel PC provides four serial ports (COM1, 3, 4: RS-232; COM2: RS-232/422/485) in one COM port connector.

## 5.4.1 COM2 RS-232/422/485 setting (JP3, JP4, JP5)

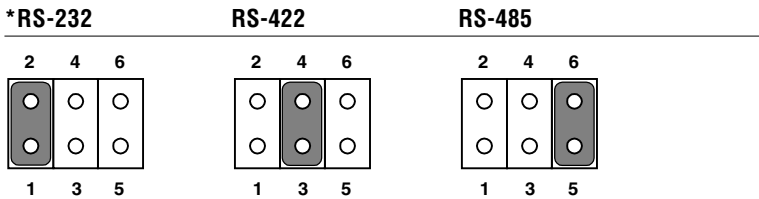
COM2 can be configured to operate in RS-232, RS-422, or RS-485 mode. This is done via JP3, JP4 and JP5.

Table 5-4: COM2 RS-232/422/485 setting (JP3, JP4)



\* default setting

Table 5-5: COM2 RS-232/422/485 setting (JP5)



\* default setting

The IRQ and the address ranges for COM1, 2, 3, and 4 are fixed. However, if you wish to disable the port or change these parameters later you can do this in the system BIOS setup. The table overleaf shows the default settings for the panel PC's serial ports.



COM1 and COM2 are one set. You can exchange the address range and interrupt IRQ of COM1 for the address range and interrupt IRQ of COM2. After exchanging, COM1's address range is 2F8 ~ 2FF and its request IRQ is IRQ3; and COM2's address range is 3F8 ~ 3FF and its interrupt IRQ is IRQ4.

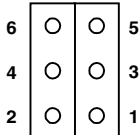
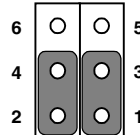
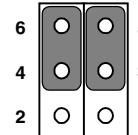
COM3 and COM4 are another set. Their selectable function is the same as the COM1/COM2 set.

Table 5-6: Serial port default settings

Port	Address Range	Interrupt
COM1	3F8 ~ 3FF	IRQ4
COM2	2F8 ~ 2FF	IRQ3
COM3	3E8 ~ 3EF	IRQ10
COM4	2E8 ~ 2EF	IRQ5

### 5.4.2 COM1 / COM2 pin 9 output type setting (JP9)

Table 5-7: COM1 / COM2 pin 9 output type setting (JP9)

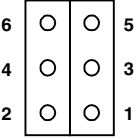
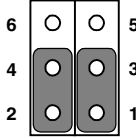
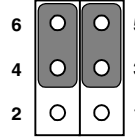
*Normal operation	+5 V output	+12 V output
		

\* default setting

*Note:* Pins 1, 3 and 5 are for COM1.  
Pins 2, 4 and 6 are for COM2.

### 5.4.3 COM3 / COM4 pin 9 output type setting (JP6)

Table 5-8: COM3/RI pin setting (JP6)

*Normal operation	+5 V output	+12 V output
		



\* default setting

*Note:* Pins 1, 3 and 5 are for COM3.  
Pins 2, 4 and 6 are for COM4.

## 5.5 Internal -12 V Source Selection Setting (JP1)

The panel PC provides an internal -12 V source in an expansion slot, available for various expansion card applications.

Table 5-9: Internal -12 V source selection setting (JP1)

* Onboard -12 V support	External -12 V input
	

\* default setting

## 5.6 VGA Interface

---

The panel PC's AGP VGA interface can drive conventional CRT displays. It is also capable of driving a wide range of flat panel displays, including electroluminescent (EL), gas plasma, passive LCD and active LCD displays. The board has two connectors to support these displays simultaneously: one for standard CRT VGA monitors, and one for flat panel displays.

CRT display port information can be found in Section 3.9 this manual.

Pin assignments for the flat panel display connector, backlight connector and other related connectors are shown in Appendix D.

### 5.6.1 LCD panel power setting

The panel PC's AGP SVGA interface supports 5 V and 3.3 V LCD displays. The LCD cable already has a built-in default setting. You do not need to adjust any jumper or switch to select the panel power.

### 5.6.2 Panel type select (SW3)

SW3 is a 8-pin dip switch for selecting panel type and display mode. A 1024 x 768 TFT LCD is used in the PPC-153, so the switch is preset according to the table below. The switch is already defaulted for the PPC-153's LCD, so it should not be modified. If you require modification for a special purpose, we recommend that you consult your distributor or our sales representative for detailed information.

---

Table 5-10: Panel type select (SW3)

Panel type	Pin 1	Pin 2	Pin 3	Pin 4	Pin 5	Pin 6	Pin 7	Pin 8
1024 x 768 (36-bit)	ON	ON	ON	OFF	ON	OFF	OFF	ON
1024 x 768 (48-bit)	ON	ON	ON	OFF	OFF	OFF	OFF	ON

---

## 5.7 Watchdog Timer Configuration

---

An onboard watchdog timer reduces the chance of disruptions which EMP (electromagnetic pulse) interference can cause. This is an invaluable protective device for standalone or unmanned applications. Setup involves one jumper and running the control software. (Refer to Appendix B.)

### 5.7.1 Watchdog activity selection (JP7)

When the watchdog timer activates (i.e. CPU processing has come to a halt), it can reset the system or generate an interrupt on IRQ11. This can be set via jumper JP7 as shown below:

---

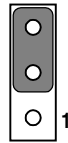
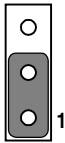
Table 5-11: Watchdog activity selection (JP7)

---

**\*System reset**

**IRQ11**

---



\* default setting

## PCI Bus Ethernet Interface

This chapter provides information on Ethernet configuration.

- Introduction
- Installation of Ethernet Driver
  - for Windows 95
  - for Windows 98
  - for Windows NT
  - for Windows 2000/ME
- Further Information

## 6.1 Introduction

---

The PPC-153 is equipped with a high performance 32-bit Ethernet chipset which is fully compliant with IEEE 802.3 100 Mbps CSMA/CD standards. It is supported by major network operating systems. It is also both 100Base-T and 10Base-T compatible. The medium type can be configured via the RSET8139.exe program included on the utility disk.

The Ethernet port provides a standard RJ-45 jack. The network boot feature can be utilized by incorporating the boot ROM image files for the appropriate network operating system. The boot ROM BIOS files are combined with system BIOS, which can be enabled/disabled in the BIOS setup.

## 6.2 Installation of Ethernet Driver

---

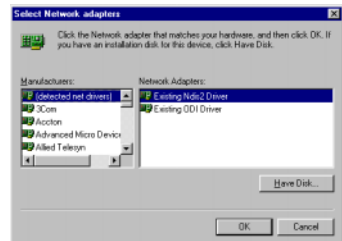
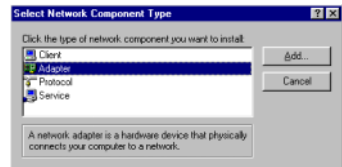
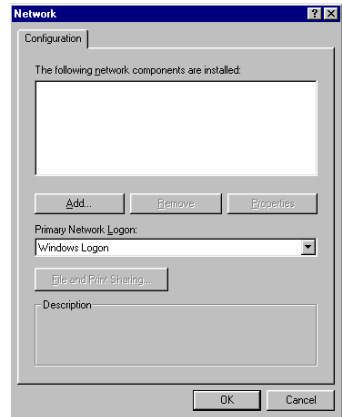
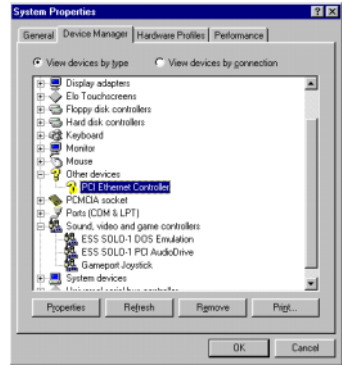
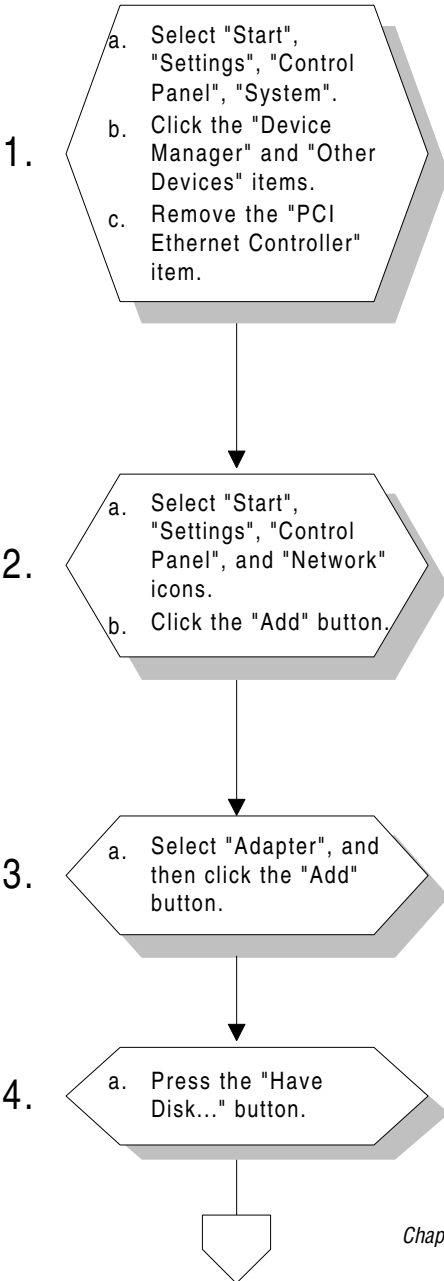
Before installing the Ethernet driver, note the procedures below. You must know which operating system you are using in your PPC-153, and then refer to the corresponding installation flow chart. Then just follow the steps described in the flow chart. You will quickly and successfully complete the installation, even if you are not familiar with instructions for Windows.

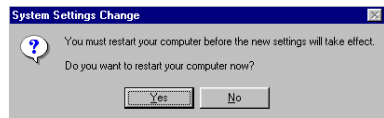
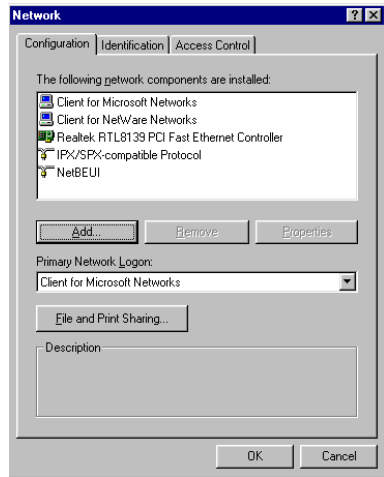
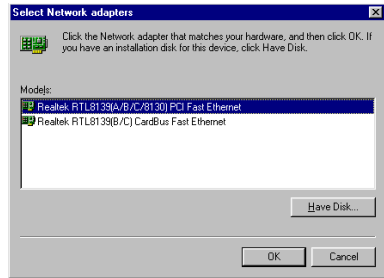
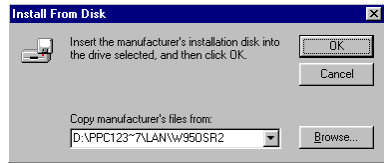
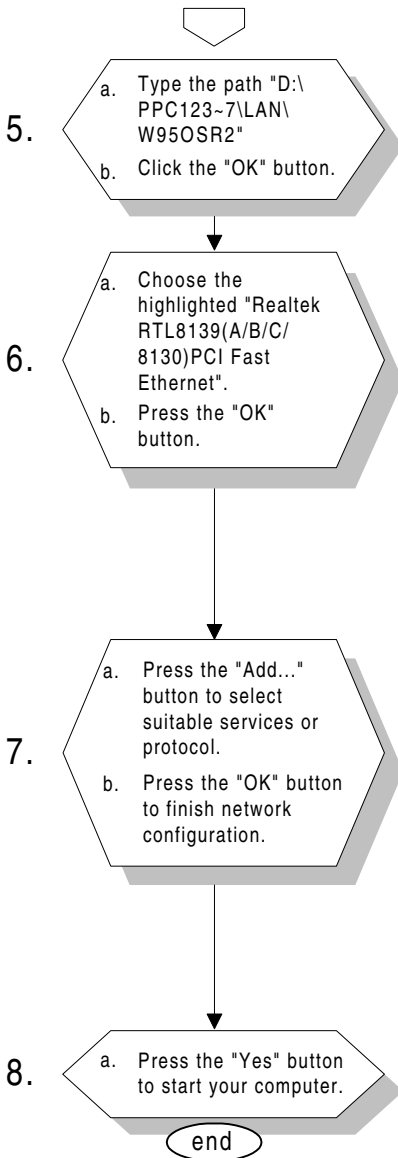
*Important: The following windows illustrations are examples only. You must follow the flow chart instructions and pay attention to the instructions which then appear on your screen.*

*Note 1: The CD-ROM drive is designated as "D" throughout this chapter.*

*Note 2: <Enter> means pressing the "Enter" key on the keyboard.*

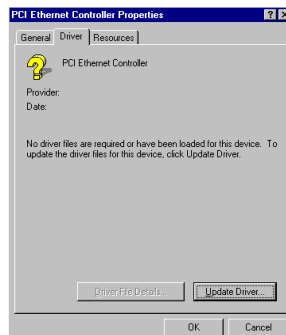
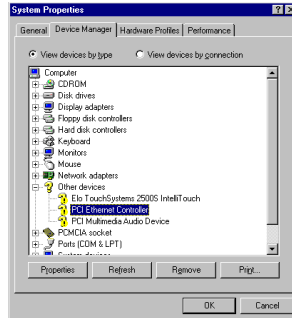
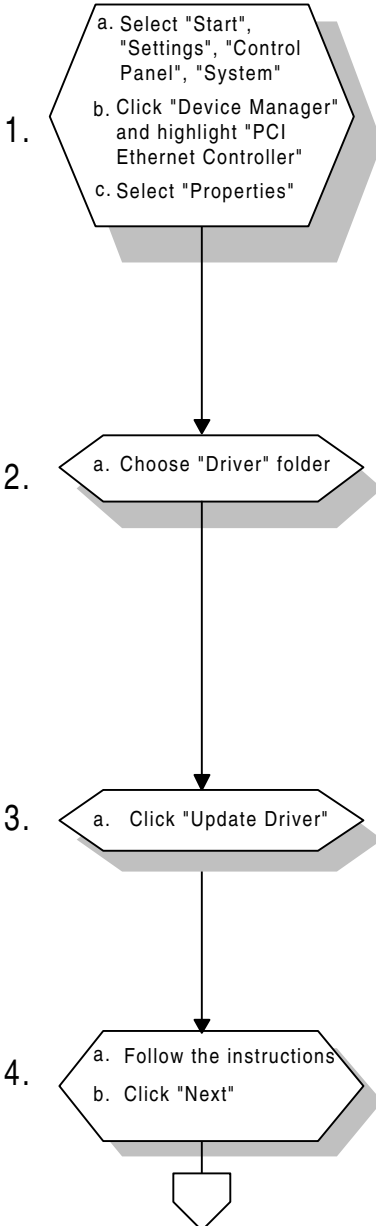
## 6.2.1 Installation for Windows 95

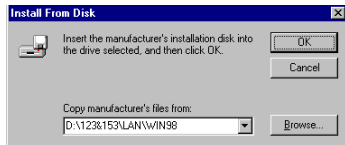
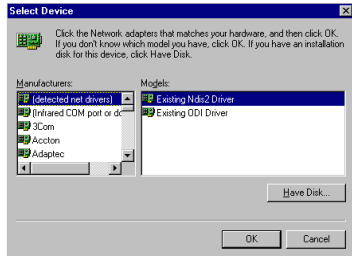
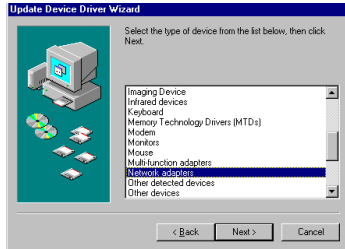
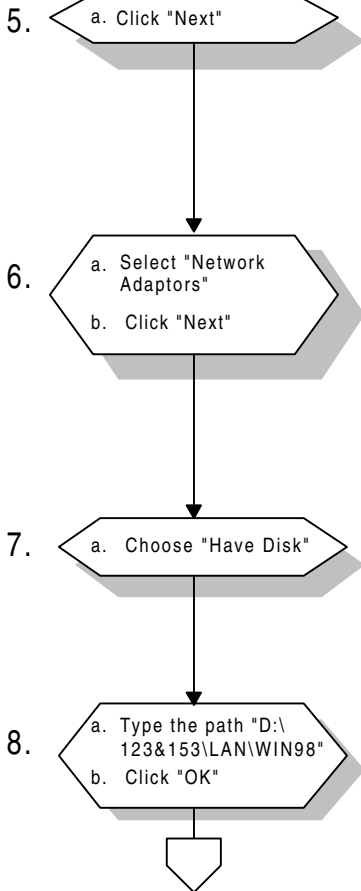


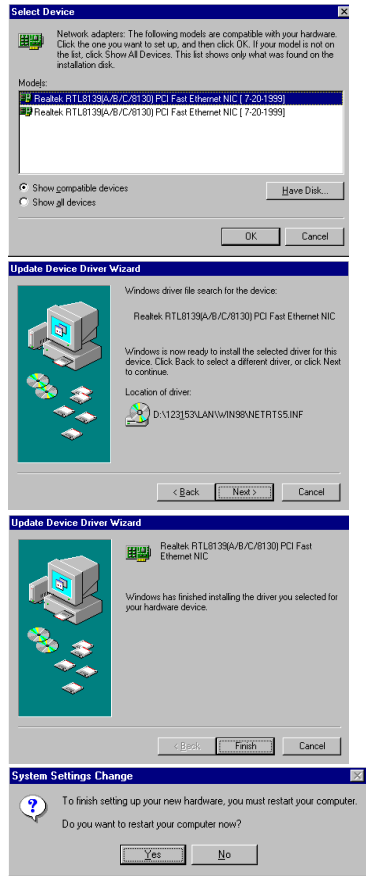
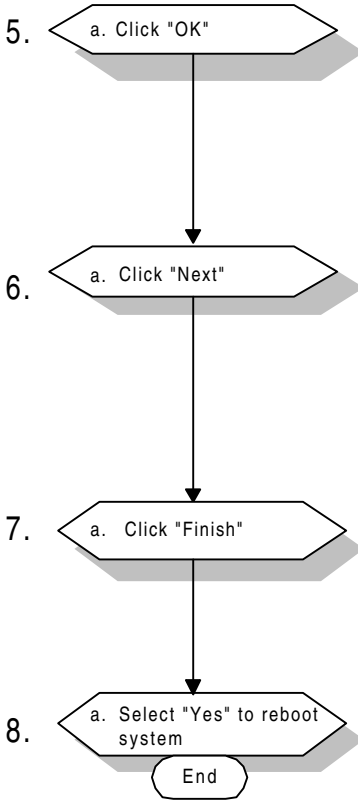




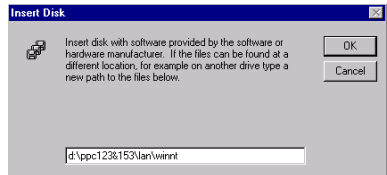
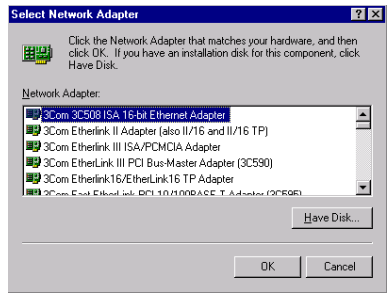
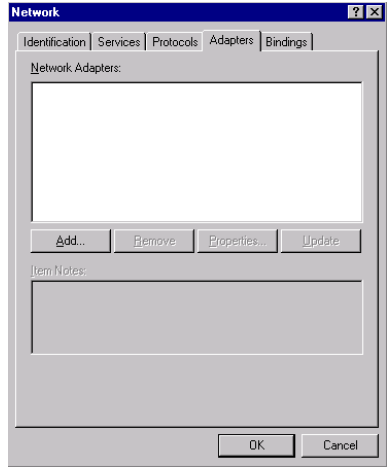
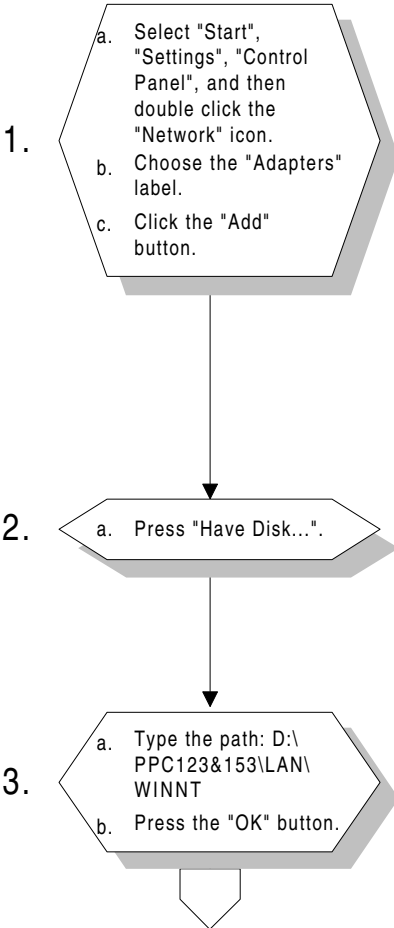
## 6.2.2 Installation for Windows 98

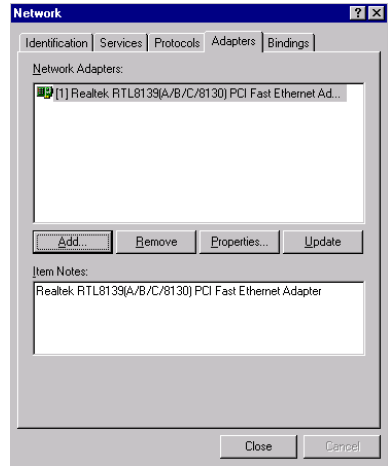
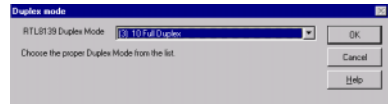
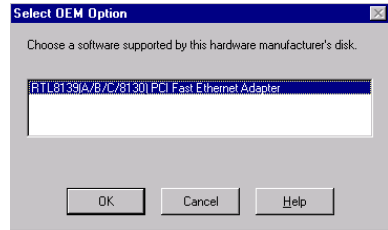
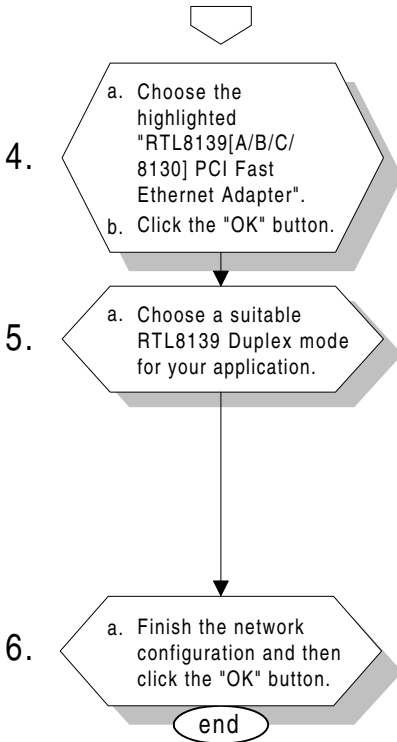






## 6.2.3 Installation for Windows NT





## **6.2.4 Installation for Windows 2000/ME**

After finishing the Windows 2000/ME installation, the system will automatically detect the Ethernet hardware and install the Ethernet driver from the drivers database from Windows 2000 or Windows ME when the system reboots.

Users are not required to install the Ethernet driver themselves.

## **6.3 Further Information**

---

Realtek website: **[www.realtek.com.tw](http://www.realtek.com.tw)**

Advantech websites: **[www.advantech.com](http://www.advantech.com)**  
**[www.advantech.com.tw](http://www.advantech.com.tw)**

# CHAPTER 7

## **AGP SVGA Setup**

- Introduction
- Installation of SVGA Driver
  - for Windows 95/98
  - for Windows NT
  - for Windows 2000
  - for Windows ME
- Further Information

## 7.1 Introduction

---

The PPC-153 has an onboard AGP flat panel/VGA interface. The specifications and features are described as follows:

### 7.1.1 Chipset

The PPC-153 uses a Lynx 3DM8 SMI 721 chipset from Silicon Motion Inc. for its AGP/SVGA controller. It supports many popular LCD, EL, and gas plasma flat panel displays and conventional analog CRT monitors. The SMI 721 VGA BIOS supports monochrome LCD, EL, color TFT and STN LCD flat panel displays. In addition, it also supports interlaced and non-interlaced analog monitors (color and monochrome VGA) in high-resolution modes while maintaining complete IBM VGA compatibility. Digital monitors (i.e. MDA, CGA, and EGA) are NOT supported. Multiple frequency (multisync) monitors are handled as if they were analog monitors.

### 7.1.2 Display memory

With onboard 8 MB display memory, the VGA controller can drive CRT displays or color panel displays with resolutions up to 1280 x 1024 at 16 M colors.

### 7.1.3 Display types

CRT and panel displays can be used simultaneously. The PPC-153 can be set in one of three configurations: on a CRT, on a flat panel display, or on both simultaneously. The system is initially set to simultaneous display mode. If you want to enable the CRT display only or the flat panel display only, contact Silicon Motion Inc. or our sales representative for detailed information.



## 7.2 Installation of SVGA Driver

---

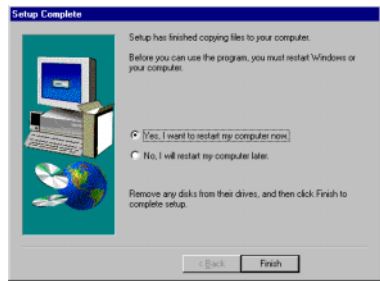
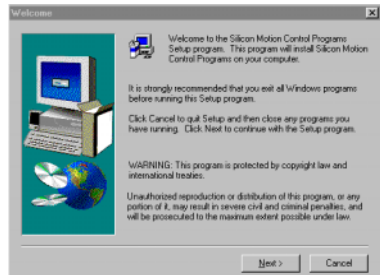
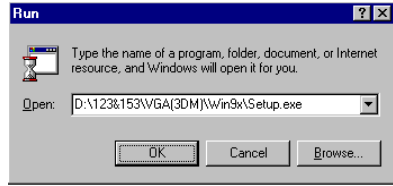
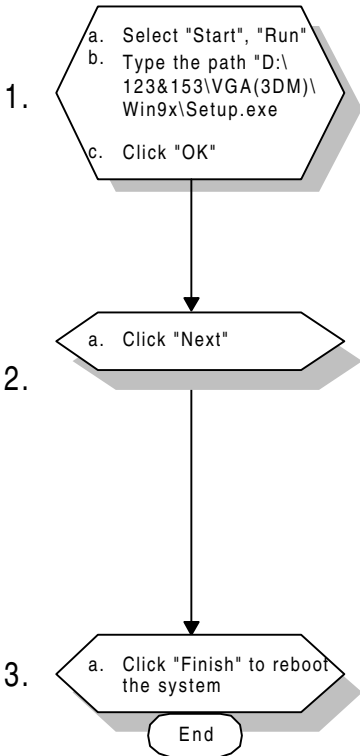
Complete the following steps to install the SVGA driver. Follow the procedures in the flow chart that apply to the operating system that you are using within your PPC-153.

*Important: The following windows illustrations are examples only. You must follow the flow chart instructions and pay attention to the instructions which then appear on your screen.*

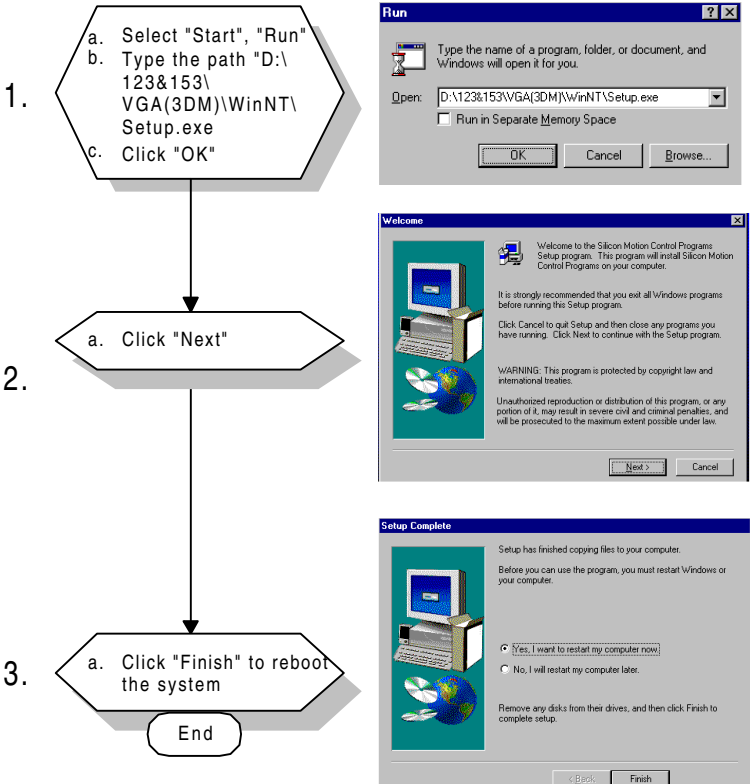
*Note 1: The CD-ROM drive is designated as "D" throughout this chapter.*

*Note 2: <Enter> means pressing the "Enter" key on the keyboard.*

## 7.2.1 Installation for Windows 95/98

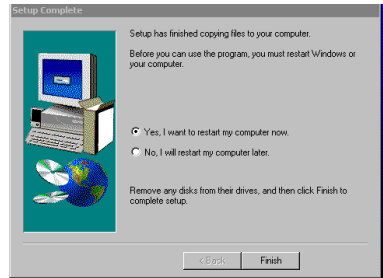
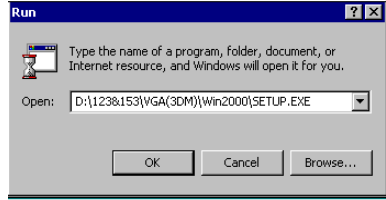
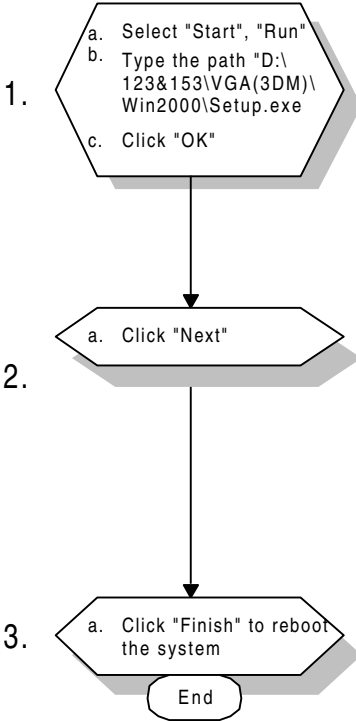


## 7.2.2 Installation for Windows NT

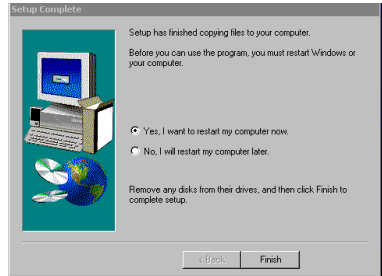
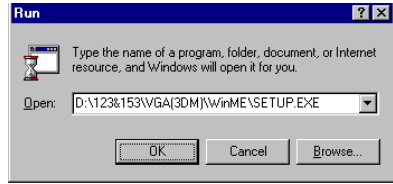
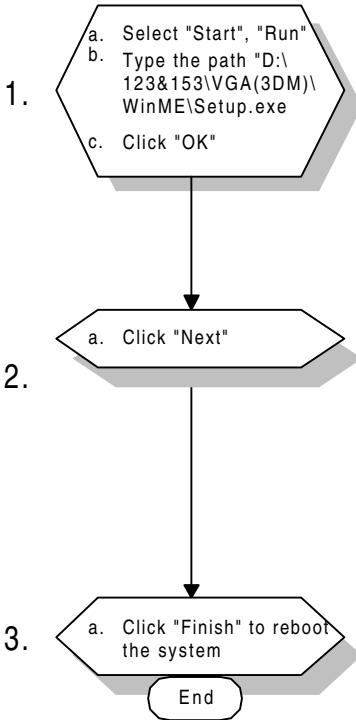


**Note:** Service Pack X (X=3, 4, 5, 6...) must be installed first before you install the Windows NT VGA driver.

## 7.2.3 Installation for Windows 2000



## 7.2.4 Installation for Windows ME



## 7.3 Further Information

---

For further information about the AGP/SVGA installation in your PPC-153, including driver updates, troubleshooting guides and FAQ lists, visit the following web resources:

Silicon Motion website: **[www.siliconmotion.com](http://www.siliconmotion.com)**

Advantech websites: **[www.advantech.com](http://www.advantech.com)**  
**[www.advantech.com.tw](http://www.advantech.com.tw)**

# CHAPTER 8

## Audio

- Introduction
- Installation of Audio Driver
  - for Windows 95/98
  - for Windows NT
  - for Windows 2000/ME

## 8.1 Introduction

---

The PPC-153's onboard audio interface provides high-quality stereo sound and FM music synthesis (ESFM) by using the ES1946S audio controller from ESS Technology, Inc. The audio interface can record, compress, and play back voice, sound, and music with a built-in mixer control. The PPC-153's onboard audio interface also supports the Plug and Play (PnP) standard and provides PnP configuration for audio, FM, and MPU-104 logical devices. It is compatible with Sound Blaster, Sound Blaster Pro version 3.01, voice, and music functions. The ESFM synthesizer is register compatible with the OPL3 and has extended capabilities.

## 8.2 Installation of Audio Driver

---

Before installing the audio driver, please take note of the procedures detailed below. You must know which operating system you are using in your PPC-153, and then refer to the corresponding installation flow chart. Just follow the steps in the flow chart. You can quickly and successfully complete the installation, even though you are not familiar with instructions for Windows.

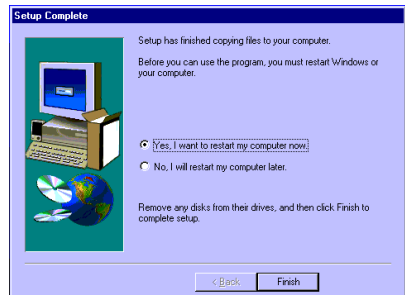
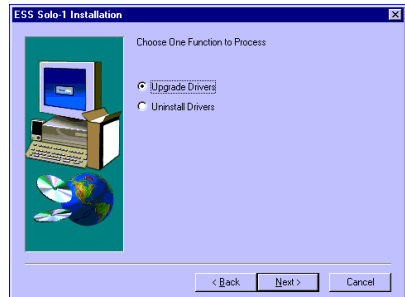
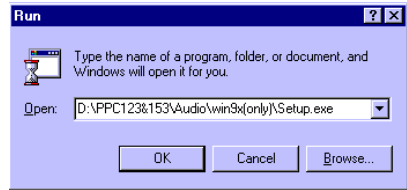
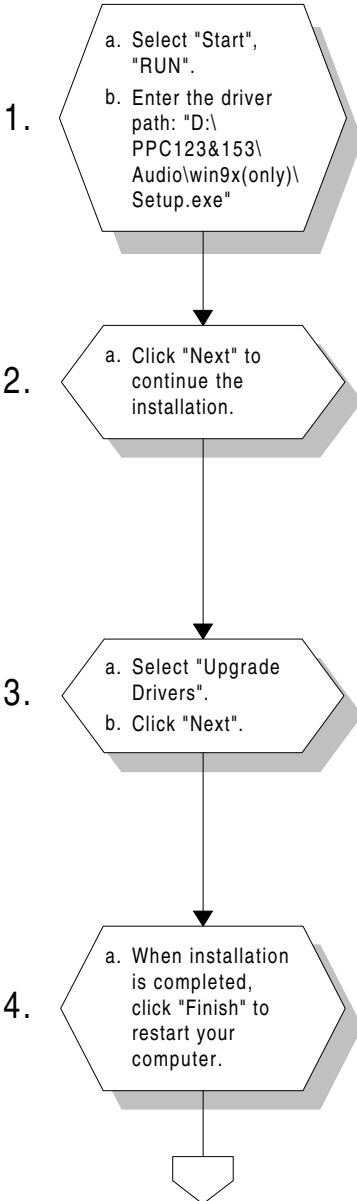
*Important: The following windows illustrations are examples only. You must follow the flow chart instructions and pay attention to the instructions which then appear on your screen.*

*Note 1: The CD-ROM drive is designated as "D" throughout this chapter.*

*Note 2: <Enter> means pressing the "Enter" key on the keyboard.*



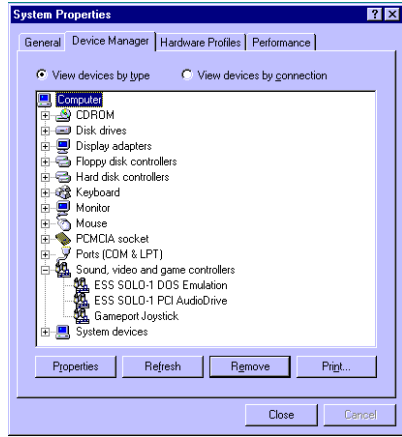
## 8.2.1 Installation for Windows 95/98



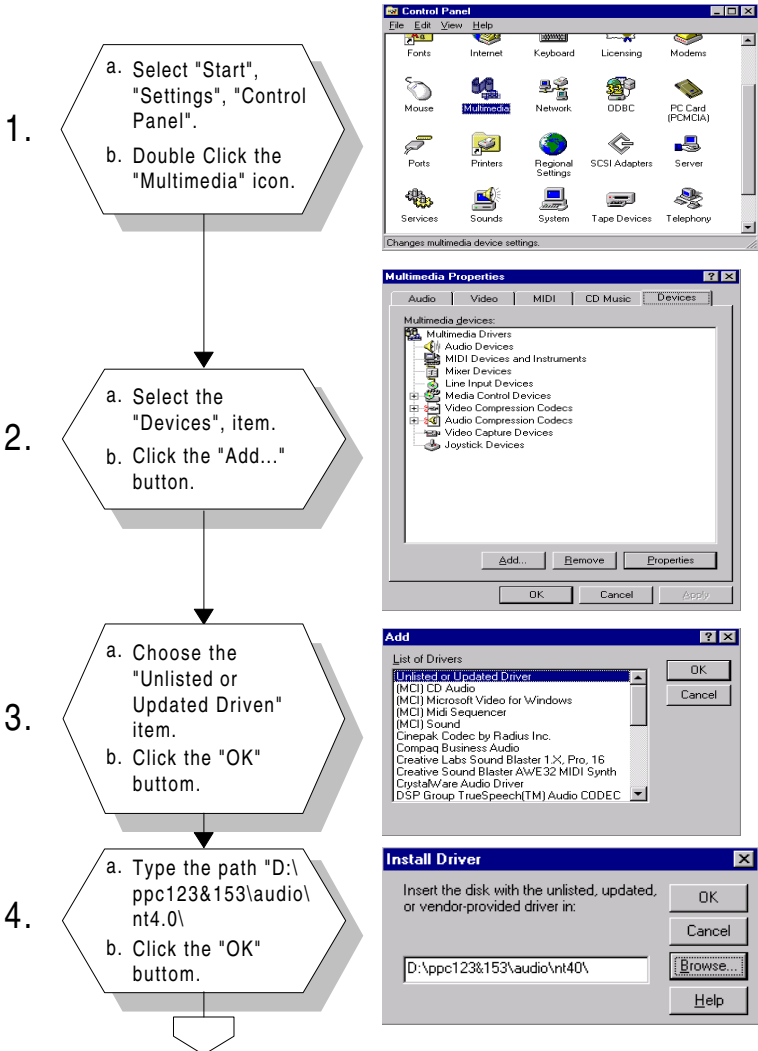
5.

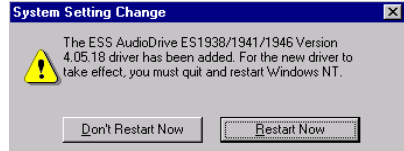
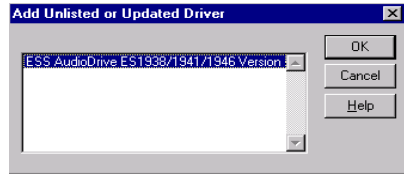
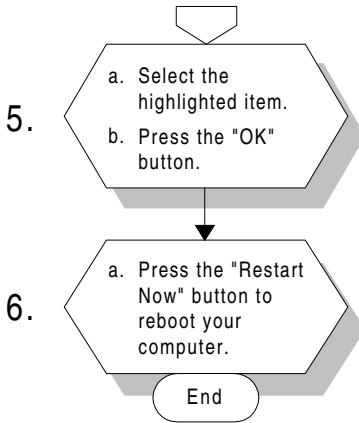
- a. After installation, select "Start", "Settings", "Control Panel", "System".
- b. Click the "Device Manager" tab to see the result of your installation.

End



## 8.2.2 Installation for Windows NT





### 8.2.3 Installation for Windows 2000/ME

After finishing the Windows 2000 or Windows ME installation, the system can automatically detect the audio hardware and install the driver from the driver database in Windows 2000 or Windows ME when the system reboots.

It is not necessary to install the audio driver manually.

# CHAPTER 9

## **Award BIOS Setup**

This chapter describes how to set BIOS configuration data.

## 9.1 Award BIOS Setup

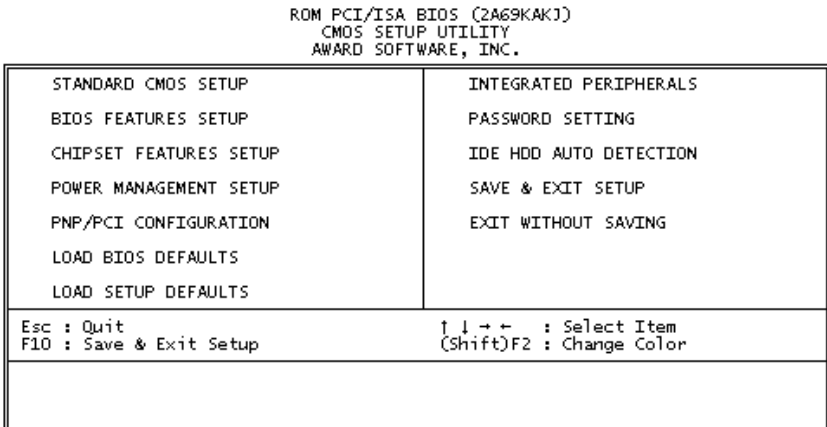
---

The PPC-153 comes with an Award BIOS chip that contains the ROM setup for your system. This chip serves as an interface between the processor and the rest of the mainboard's components. This chapter explains the information contained in the setup program and tells you how to modify the settings according to your system configuration. Some setup items will not be explained, because it is recommended that users do not change such items.

*Note: Values for the various setup items that appear on your own screen (including default values) may not be the same as the values shown on the screen figures in this chapter. This is because the BIOS is revised and updated from time to time. If in doubt, check Advantech's website for the latest BIOS versions and related information.*

## 9.2 CMOS Setup Utility

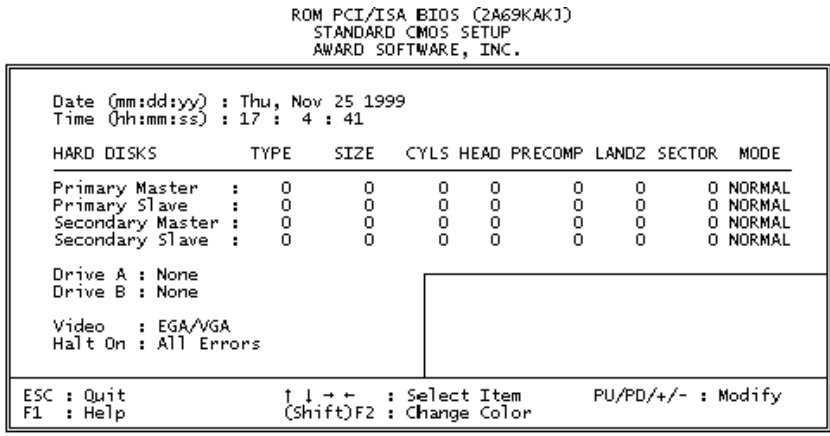
---



**Figure 9-1: Setup program initial screen**

A setup program, built into the system BIOS, is stored in the CMOS RAM that allows the configuration settings to be changed. This program is executed when the user changes the system configuration; when the user changes the system backup battery; or when the system detects a configuration error and asks the user to run the setup program. At power-on RAM testing, the message "Press DEL to enter Setup" appears. After pressing the "DEL" key, the CMOS setup utility screen will appear as shown in Fig. 9-1. Use the arrow keys to select and press "Enter" to run the selected program.

### 9.3 Standard CMOS Setup



**Figure 9-2: CMOS setup screen**

The standard CMOS setup screen is shown above. System BIOS automatically detects memory size, so no changes are necessary. It has a few items requiring setting. Each item may have one or more optional settings. System BIOS allows you to change the system date and time, IDE hard disk, floppy disk drive types for drives A: and B:, boot-up video display mode, and POST error handling selection. Use the arrow keys to highlight the item and then use the "PgUp" or "PgDn" keys to select the value you want for each item.

### **9.3.1 Hard disk configurations**

#### **TYPE**

Select from 1 to 45 to fill the remaining fields with predefined values for disk drives. Select "User" to fill the remaining fields. Select "Auto" to detect the HDD type automatically.

#### **SIZE**

Hard disk size. The unit is megabytes (MB).

#### **CYLS**

The cylinder number of the hard disk.

#### **HEAD**

The read/write head number of the hard disk.

#### **PRECOMP**

The cylinder number at which the disk drive changes the write timing.

#### **LANDZ**

The cylinder number where the disk drive heads (read/write) are seated when the disk drive is parked.

#### **SECTOR**

The sector number of each track defined on the hard disk.

#### **MODE**

Select "Auto" to detect the mode type automatically. If your hard disk supports the LBA mode, select "LBA" or "Large". However, if your hard disk supporting cylinder is more than 1024 MB and does not support the LBA function, you have to select "Large". If your hard disk supporting cylinder is below 1024 MB, select "Normal".



## 9.4 BIOS Features Setup

ROM PCI/ISA BIOS (2A69KAK1)  
BIOS FEATURES SETUP  
AWARD SOFTWARE, INC.

Virus Warning	: Disabled	Video BIOS Shadow	: Enabled
CPU Internal Cache	: Enabled	C8000-CBFFF Shadow	: Disabled
External Cache	: Enabled	CC000-CFFFF Shadow	: Disabled
CPU L2 Cache ECC Checking	: Enabled	D0000-D3FFF Shadow	: Disabled
Processor Number Feature	: Enabled	D4000-D7FFF Shadow	: Disabled
Quick Power On Self Test	: Enabled	D8000-DBFFF Shadow	: Disabled
Boot From LAN First	: Disabled	DC000-DFFFF Shadow	: Disabled
Boot Sequence	: C,A,SCSI		
Swap Floppy Drive	: Disabled		
Boot Up Floppy Seek	: Enabled		
Boot Up NumLock Status	: On		
Gate A20 Option	: Fast		
Typeomatic Rate Setting	: Disabled		
Typeomatic Rate (Chars/Sec)	: 6		
Typeomatic Delay (Msec)	: 250		
Security Option	: Setup	ESC : Quit	↑↓←→ : Select Item
PS/2 mouse function control	: Enabled	F1 : Help	PU/PD/+/- : Modify
PCI/VGA Palette Snoop	: Disabled	F5 : Old Values (Shift)	F2 : Color
OS Select For DRAM > 64MB	: Non-OS2	F6 : Load BIOS Defaults	
Report No FDD For WIN 95	: Yes	F7 : Load Setup Defaults	

**Figure 9-3: BIOS features setup screen**

Moving around the BIOS Features and Chipset Features setup programs works the same way as moving around the Standard CMOS setup program. (Refer to the next section for Chipset Features setup.) The BIOS Features setup program is shown above. Users are not encouraged to run the BIOS and Chipset Features setup programs. Your system should have been fine-tuned before shipping. Improper setup may cause the system to fail, so consult your dealer before making any changes.

### **Virus Warning**

When enabled, it assigns the BIOS to monitor the master boot sector and the DOS sector of the first hard disk drive.

The options are: Disabled (Default), Enabled.

**CPU Internal Cache**

When enabled, it improves system performance. Disable this item when testing or troubleshooting.

The options are: Enabled (Default), Disabled.

**External Cache**

When enabled, supports an external cache SRAM.

The options are: Enabled (Default), Disabled.

**CPU L2 Cache ECC Checking**

Allows the CPU L2 cache to enable the memory parity check.

The options are: Disabled (Default), Enabled.

**Quick Power On Self Test**

When enabled, allows the BIOS to bypass the extensive memory test.

The options are: Disabled (Default), Enabled.

**Boot From LAN First**

Enables the system to boot from a LAN.

The options are: Disabled (Default), Enabled.

**Boot Sequence**

Allows the system BIOS to first try to boot the operating system from the selected disk drive.

The options are:

C, A, SCSI (Default)

LS/ZIP, C

C (only)

SCSI, C, A

SCSI, A, C

F, A, SCSI

E, A, SCSI

D, A, SCSI

CDROM, C, A

C, CDROM, A

### **Swap Floppy Drive**

When enabled, allows you to switch the order in which the operating system accesses the floppy drives during boot-up.

The options are: Disabled (Default), Enabled.

### **Boot Up Floppy Seek**

When enabled, assigns the BIOS to perform floppy disk drive tests by issuing seek commands. Note that such tests are time-consuming.

The options are: Enabled (Default), Disabled.

### **Boot Up NumLock Status**

When set to "On", allows the BIOS to automatically enable the NumLock function when the system boots up.

The options are: On (Default), Off.

### **Typematic Rate Setting**

The term typematic means that when a keyboard key is held down, the character is repeatedly entered until the key is released. When this item is enabled, you may change the typematic repeat rate.

The options are: Disabled (Default), Enabled.

### **Typematic Rate (Chars/Sec)**

Sets the rate of a character repeat when the key is held down.

The options are: 6 (Default), 8, 10, 12, 15, 20, 24, 30.

### **Typematic Delay (msec)**

Sets the delay time before a character is repeated.

The options are: 250 (Default), 500, 750, 1000 milliseconds.

**Security Option**

Allows you to set the security level of the system.

The options are: Setup (Default), System.

**PS/2 Mouse Function Control**

When enabled, the PS/2 mouse is activated.

The options are: Disabled (Default), Enabled.

**PCI/VGA Palette Snoop**

When enabled, allows you to install an enhanced graphics adapter card. If your graphics adapter card does not support the Palette Snoop function, set at "Disabled" to avoid system malfunctions.

The options are: Disabled (Default), Enabled.

**OS Select For DRAM > 64MB**

If your operating system (OS) is OS2, select "OS2". Otherwise, stay with the default setting Non-OS2.

**Report No FDD For WIN 95**

Assigns IRQ6 for the FDD.

The options are: Yes (Default), No.

**Video BIOS Shadow**

When enabled, allows the BIOS to copy the video ROM code of the add-on video card to the system memory, giving faster access.

The options are: Enabled (Default), Disabled.

**C8000-CBFFF Shadow through to DC000-DFFFF Shadow**

When enabled, allows the BIOS to copy the BIOS ROM code of the add-on card to the system memory for faster access. It may improve the performance of the add-on card. Some add-on cards will not function properly if their BIOS ROM codes are shadowed. To use this option correctly, you need to know the memory address range used by the BIOS ROM of each add-on card.

The options are: Disabled (Default), Enabled.

## 9.5 Chipset Features Setup

*Note: It is strongly recommended that setup items in this section NOT be changed, because advanced knowledge is required to effect such changes.*

ROM PCI/ISA BIOS (2A69KAKJ)  
CHIPSET FEATURES SETUP  
AWARD SOFTWARE, INC.

Auto Configuration : Enabled	Power-Supply Type : AT
EDO DRAM Speed Selection : 60ns	Auto Detect DIMM/PCI Clk : Enabled
EDO CASX# MA Wait State : 2	Spread Spectrum : Disabled
EDO RASX# Wait State : 1	CPU Host Clock (CPU/PCI) : Default
SDRAM RAS-to-CAS Delay : 3	CPU Warning Temperature : Disabled
SDRAM RAS Precharge Time : 3	Current System Temp. :
SDRAM CAS latency Time : Auto	Current CPU Temperature :
SDRAM Precharge Control : Disabled	Current System Fan Speed :
DRAM Data Integrity Mode : Non-ECC	Current CPU Fan Speed :
System BIOS Cacheable : Enabled	Vcore : +3.3V
Video BIOS Cacheable : Enabled	+ 5 V : +12 V
Video RAM Cacheable : Enabled	-12 V :-
8 Bit I/O Recovery Time : 1	-
16 Bit I/O Recovery Time : 1	ESC : Quit ↑↓←→ : Select Item
Memory Hole At 15M-16M : Disabled	F1 : Help PU/PD/+/- : Modify
Passive Release : Enabled	F5 : Old Values (Shift)F2 : Color
Delayed Transaction : Disabled	F6 : Load BIOS Defaults
AGP Aperture Size (MB) : 64	F7 : Load Setup Defaults

**Figure 9-4: Chipset features setup screen**

### **EDO CASX# MA Wait State**

Sets the EDO CASX# MA wait state.

The options are: 1 (Default), 2.

### **EDO RASX# Wait State**

Sets the EDO RASX# wait state.

The options are: 1 (Default), 2.

### **SDRAM CAS Latency Time**

Sets the SDRAM CAS latency time.

The options are: Auto (Default), 2, 3.

**SDRAM Data Integrity Mode**

When set as Non-ECC, supports standard 64-bit DIMM RAM modules. When set as ECC, supports standard 72-bit ECC RAM modules.

The options are: Non-ECC (Default), ECC.

**System BIOS Cacheable**

When enabled, allows the ROM area F000H-FFFFH to be cacheable when the cache controller is activated. The recommended setting is "Disabled", especially for high speed CPUs (200 MHz and above).

**Video BIOS Cacheable**

When enabled, allows the system to use the video BIOS codes from SRAMs, instead of the slower DRAMs or ROMs.

The options are: Enabled (Default), Disabled.

**Video RAM Cacheable**

Enables video RAM to be cacheable.

The options are: Disabled (Default), Enabled.

**16 Bit I/O Recovery Time**

Sets 16-bit I/O signal recovery time.

The options are: 1 (Default), 2, 3, 4, N/A.

**Memory Hole at 15M-16M**

When enabled, the memory hole at the 15 MB address will be relocated to the 15 ~ 16 MB address range of the ISA cycle when the processor accesses the 15 ~ 16 MB address area.

When disabled, the memory hole at the 15 MB address will be treated as a DRAM cycle when the processor accesses the 15 ~ 16 MB address.

The options are: Disabled (Default), Enabled.

### Delayed Transaction

When disabled, the system operates normally. When enabled, the system can support lower-speed ISA devices.

The options are: Disabled (Default), Enabled.

### Spread Spectrum

When disabled, the system operates normally. When enabled, the spread spectrum will be set to 0.5% (CNTR).

The options are: Disabled (Default), Enabled.

## 9.6 Power Management Setup

ROM PCI/ISA BIOS (2A69KAKJ) POWER MANAGEMENT SETUP AWARD SOFTWARE, INC.		
Power Management	: User Define	** Reload Global Timer Events **
PM Control by APM	: Yes	IRQ[3-7,9-15],NMI : Disabled
Video Off Method	: V/H SYNC+Blank	Primary IDE 0 : Disabled
Video Off After	: Standby	Primary IDE 1 : Disabled
MODEM Use IRQ	: 3	Secondary IDE 0 : Disabled
Doze Mode	: Disable	Secondary IDE 1 : Disabled
Standby Mode	: Disable	Floppy Disk : Disabled
Suspend Mode	: Disable	Serial Port : Enabled
HDD Power Down	: Disable	Parallel Port : Disabled
Throttle Duty Cycle	: 62.5%	
PCI/VGA Act-Monitor	: Disabled	
Soft-Off by PWR-BTTN	: Instant-Off	
PWRON After PWR-Fail	: Always Off	
PowerOn by Ring	: Disabled	
IRQ 8 Break Suspend	: Disabled	
		ESC : Quit            f1← : Select Item
		F1 : Help            PU/PD/+/- : Modify
		F5 : Old Values    (Shift)F2 : Color
		F6 : Load BIOS Defaults
		F7 : Load Setup Defaults

**Figure 9-5: Power management setup screen**

### Power Management

When enabled, allows you to use Power Management features.

The options are: Disabled (Default), Enabled.

**PM Control by APM**

The option "No" allows the BIOS to ignore the APM (Advanced Power Management) specification. Selecting "Yes" will allow the BIOS to wait for APM's prompt before it enters Doze mode, Standby mode, or Suspend mode. If the APM is installed, it will prompt the BIOS to set the system into power saving mode after all tasks are done.

The options are: Yes (Default), No.

**Video Off Option**

This feature provides the selections for the video display power saving mode. The option "Susp, Stby → Off" allows the video display to go blank if the system enters Suspend or Standby mode. The option "Suspend → Off" allows the video display to go blank if the system enters Suspend mode. The option "All Modes → Off" allows the video display to go blank if the system enters Doze mode or Suspend mode. The option "Always On" allows the video display to stay in Standby mode even when the system enters Doze or Suspend mode.

The options are: Susp, Stby → Off (Default), Suspend → Off, All Modes → Off, Always On.

**Video Off Method**

"DPMS Supported" allows the BIOS to blank off the screen display with your VGA card which supports DPMS (Display Power Management Signaling function). "Blank Screen" allows the BIOS to blank the screen display by turning off the red-green-blue signals.

The options are: DPMS Supported (Default), Blank Screen.

**MODEM Use IRQ**

This feature allows you to select the IRQ# to meet your modem's IRQ#.

The options are: 3 (Default), 4, 5, 7, 9, 10, 11, NA.

**Doze Mode**

The system will not enter Doze mode, because this option is designated as "Disabled".

**Standby Mode**



The system will not enter Standby mode, because this option is designated as "Disabled".

### **Suspend Mode**

The system will not enter Suspend mode, because this option is designated as "Disabled".

### **HDD POWER Down**

Selecting "Disabled" will turn off the hard disk drive (HDD) motor. Selecting "1 Min.. 15 Min" allows you to define the HDD idle time before the HDD enters Power Saving Mode.

The options "1 Min.. 15 Min" and "When Suspend" will not work concurrently. When the HDD is in Power Saving Mode, any access to the HDD will wake it up.

The options are: Disabled (Default), 1 Min., 15 Min.

### **PNP OS Installed**

Select Yes if the installed system supports the PnP function. Select No if the installed system does not support the PnP function.

The options are: No (Default), Yes.

*Note: Under certain operating systems such as Windows NT 4.0 (Build 1381), the CD auto-insertion feature might have some effect on power management. It is recommended that the CD-ROM drive use the secondary channel, and that the following Power Management Setup features be set:  
HDD & FDD: Off  
IRQ15 (Reserved): Secondary*

# 9.7 PNP/PCI Configuration Setup

ROM PCI/ISA BIOS (2A69KA<J>)  
PNP/PCI CONFIGURATION  
AWARD SOFTWARE, INC.

PNP OS Installed : No Resources Controlled By : Manual Reset Configuration Data : Disabled	Used MEM base addr : N/A Assign IRQ For USB : Disabled
IRQ-3 assigned to : PCI/ISA PnP IRQ-4 assigned to : PCI/ISA PnP IRQ-5 assigned to : PCI/ISA PnP IRQ-7 assigned to : PCI/ISA PnP IRQ-9 assigned to : PCI/ISA PnP IRQ-10 assigned to : PCI/ISA PnP IRQ-11 assigned to : PCI/ISA PnP IRQ-12 assigned to : PCI/ISA PnP IRQ-14 assigned to : PCI/ISA PnP IRQ-15 assigned to : PCI/ISA PnP DMA-0 assigned to : PCI/ISA PnP DMA-1 assigned to : PCI/ISA PnP DMA-3 assigned to : PCI/ISA PnP DMA-5 assigned to : PCI/ISA PnP DMA-6 assigned to : PCI/ISA PnP DMA-7 assigned to : PCI/ISA PnP	ESC : Quit            F10 : Select Item F1 : Help            PU/PD/+/- : Modify F5 : Old values (Shift) F2 : Color F6 : Load BIOS Defaults F7 : Load Setup Defaults

Figure 9-6: PNP/PCI configuration setup screen

### PNP OS Installed

Select Yes if the installed system supports the PnP function. Select No if the installed system does not support the PnP function.

The options are: No (Default), Yes.

### Resources Controlled By

If set at "Auto", the BIOS automatically arranges all system resources for you. If there are conflicts or you are not satisfied with the configuration, simply set all the resources listed in the above figure by selecting "Manual".

The options are: Manual (Default), Auto.

The manual options assigned to IRQ-/DMA- are: Legacy ISA, PCI/ISA PnP.

### Reset Configuration Data

When enabled, this feature allows the system to clear the last BIOS configuration data and then reset the data with the default BIOS configuration data.

The options are: Disabled (Default), Enabled.

### Used MEM base addr

Choose and use the MEM base address.

The options are: N/A (Default), C800 ~ DC00.

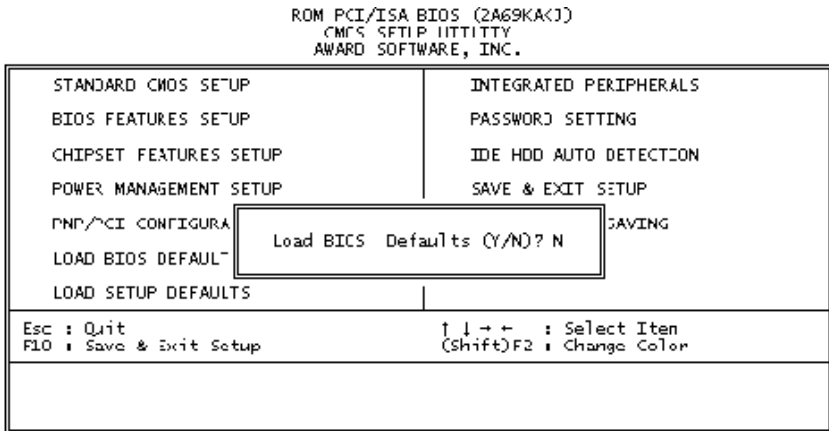
### Assign IRQ for USB

Assigns an IRQ for the USB.

The options are: Disabled (Default), Enabled.

## 9.8 Load BIOS Defaults

---



**Figure 9-7: Load BIOS defaults screen**

The BIOS defaults screen contains the most appropriate values of the system parameters that allow minimum system performance.

## 9.9 Load Setup Defaults

Selecting this field loads the factory defaults for BIOS and Chipset Features. The system will automatically detect these defaults.

## 9.10 Integrated Peripherals

```
ROM PCI/ISA BIOS (2A69KAKJ)
INTEGRATED PERIPHERALS
AWARD SOFTWARE, INC.
```

IDE HDD Block Mode	: Enabled	Onboard Serial Port 2 IRQ:	3
On-Chip Primary PCI IDE:	Enabled	UART Mode Select	:
On-Chip Secondary PCI IDE:	Enabled	UART2 Duplex Mode	: Half
IDE Primary Master PIO	: Auto	RxD , TxD Active	: Hi,Lo
IDE Primary Slave PIO	: Auto	IR Transmittiion delay	: Enabled
IDE Secondary Master PIO	: Auto	Onboard Parallel Port	:
IDE Secondary Slave PIO	: Auto	Onboard Parallel Port IRQ:	7
IDE Primary Master UDMA	: Auto	Parallel Port Mode	:
IDE Primary Slave UDMA	: Auto	ECP Mode Use DMA	: 3
IDE Secondary Master UDMA:	Auto	EPP Mode Select	: EPP1.7
IDE Secondary Slave UDMA:	Auto	Onboard Serial Port 3	: 3E8H
Onboard PCI Lan Chip	: Enabled	Serial Port 3 Use IRQ	: IRQ10
USB Keyboard Support	: Disabled	Onboard Serial Port 4	: 2E8H
Init Display First	: PCI Slot	Serial Port 4 Use IRQ	: IRQ5
KBC input clock	: 8 MHz		
Onboard FDC Controller	: Enabled		
Onboard Serial Port 1	:		
Onboard Serial Port 1 IRQ:	4		
Onboard Serial Port 2	:		

**Figure 9-8: Integrated peripherals screen**

### IDE HDD Block Mode

This allows your hard disk controller to use the fast block mode to transfer data to and from your hard disk drive (HDD).

The options are: Enabled (Default), Disabled.

### IDE Primary/Secondary Master/Slave PIO

IDE hard disk drive controllers can support up to separate hard drives.

These drives have a master/slave relationship which is determined by the cabling configuration used to attach them to the controller. Your system supports two IDE controllers - a primary and a secondary - so you have the ability to install up to four separate hard disks.

PIO means Programmed Input/Output. Rather than having the BIOS issue a series of commands to effect a transfer to or from the disk drive, PIO allows the BIOS to tell the controller what it wants and then let the controller and the CPU perform the task by themselves.

Your system supports five modes, numbered from 0 through 4, which differ primarily in timing. When "Auto" is selected, the BIOS will choose the best available mode.

The options are: Auto, (Default), Disabled.

#### **Primary/Secondary Master/Slave Ultra DMA**

DMA means Direct Memory Access. Ultra DMA is faster than DMA. DMA is a method of transferring data to or from memory at a fast rate, without involving the CPU.

When you select "Auto", the BIOS will choose the best available mode.

The options are: Auto (Default), Disabled.

#### **Onboard FDD Controller**

When enabled, the floppy disk drive (FDD) controller is activated.

The options are: Enabled (Default), Disabled.

#### **Onboard Serial Ports 1 & 2**

If the serial ports use the onboard I/O controller, you can modify your serial port parameters.

The options for Port 1 are: 3F8/IRQ4 (Default), 2E8/IRQ3, Disabled, 2F8/IRQ3, 3E8/IRQ4.

The options for Port 2 are: 2F8/IRQ3 (Default), 3E8/IRQ4, 2E8/IRQ3, Disabled, 3F8/IRQ4.

#### **Onboard Serial Ports 3 & 4**

If the serial ports use the onboard I/O controller, you can modify your serial port parameters.

The options for Port 3 are: 3E8/IRQ10 (Default), 2E8/IRQ5, Disabled.

The options for Port 4 are: 2E8/IRQ5 (Default), Disabled, 3E8/IRQ10.

**Onboard Parallel Port**

If the parallel port uses the onboard I/O controller, you can modify your parallel port parameters. When you select "Disabled", the next two setup items will disappear.

The options are: 378/IRQ7 (Default), 3BC/IRQ7, 278/IRQ5, Disabled.

**Parallel Port Mode**

You can choose different data transfer modes for your system.

The options are: ECP & EPP (Default), SPP, EPP, ECP.

**ECP Mode Use DMA**

You can choose different DMA modes for data transfer.

The options are: 3 (Default), 1.

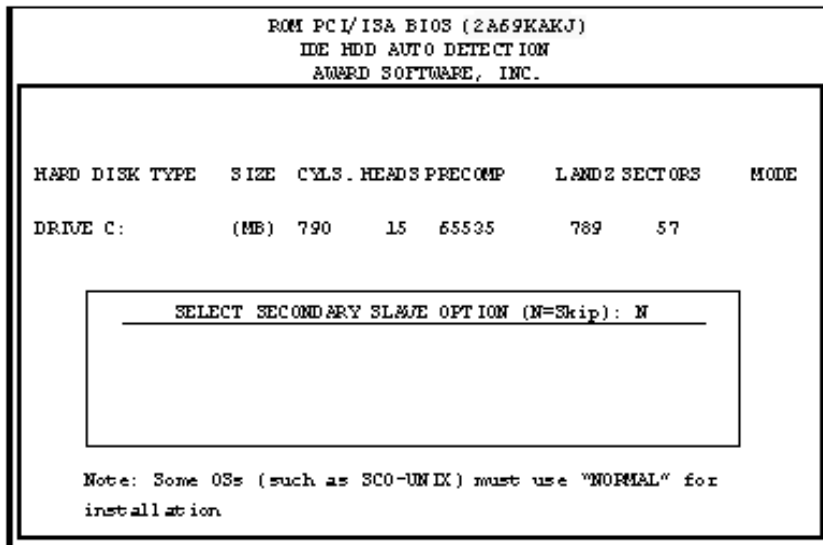
## 9.11 Password Setting

---

To enable the password setting, select the item from the Standard CMOS Setup. You will be prompted to create your own password. Type your password up to eight characters and press "Enter". You will be asked to confirm the password. Type the password again and press "Enter". You may also press "Esc" to abort the selection and not enter a password. To disable the password, press "Enter" when you are prompted to enter the password. A message will appear, confirming the password is disabled.

Under the BIOS Features setup, if "System" is selected under the Security Option field and the Supervisor Password is enabled, you will be prompted for the supervisor password every time you try to enter the CMOS Setup utility. If "System" is selected and User Password is enabled, you will be requested to enter the user password every time you reboot the system. If "Setup" is selected under the Security Option field and User Password is enabled, you will be prompted only when you reboot the system.

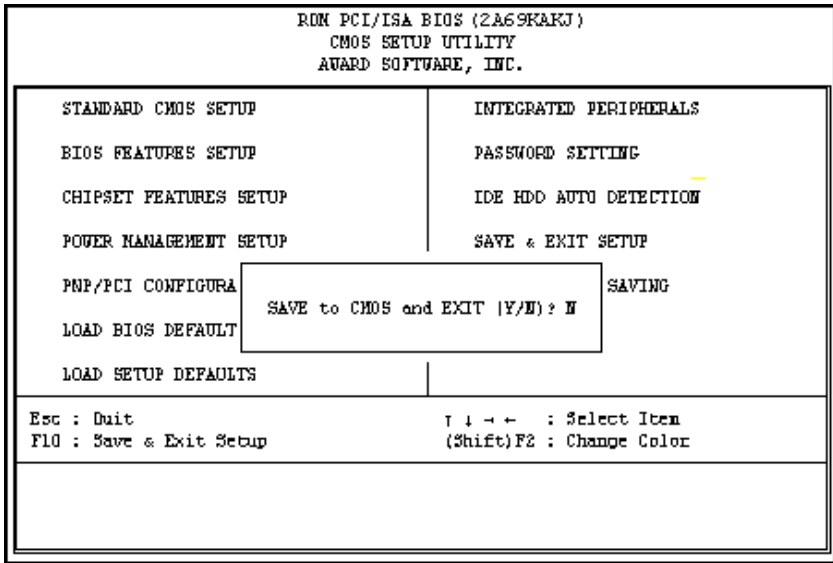
## 9.12 IDE HDD Auto Detection



**Figure 9-9: IDE HDD auto detection screen**

The IDE Hard Disk Drive Auto Detection feature automatically configures your new hard disk. Use it for quick configuration of new hard disk drives. This feature allows you to set the parameters of up to four IDE HDDs. The option with "(Y)" is recommended by the system BIOS. You may also key in your own parameters instead of setting them according to the system BIOS. After keying in all settings, press "Esc" to return to the main menu. For confirmation, enter the Standard CMOS Setup feature.

## 9.13 Save and Exit Setup



**Figure 9-10: Save and exit setup screen**

After you have made changes in the BIOS setup, press "Esc" to return to the main menu. Move the cursor to "Save and Exit Setup", or press "F10" and then press "Y", to change the CMOS Setup. If you did not change anything, press "Esc" again or move the cursor to "Exit Without Saving" and press "Y" to retain the setup settings. The following message will appear at the center of the screen to allow you to save data to CMOS and exit the setup utility:

```
SAVE to CMOS and EXIT (Y/N)?
```

## 9.14 Exit Without Saving

If you select this feature, the following message will appear at the center of the screen to allow you to exit the setup utility without saving CMOS modifications:

```
Quit Without Saving (Y/N) ?
```



# CHAPTER 10

## PCMCIA

- Introduction
- Installation of PCMCIA Driver
  - for Windows 95

## 10.1 Introduction

---

The PPC-153 is equipped with a high performance PCMCIA interface which complies with the 1995 PCMCIA card standard by using the RICOH Cardbus controller. The panel PC supports two PCMCIA card/cardbus slots. Two sockets support both a 16-bit PCMCIA card and a 32-bit Cardbus simultaneously, with hot insertion and removal.

## 10.2 Installation of PCMCIA Driver

---

The PCMCIA driver for Windows 95 is included in the "Drivers and Utilities" CD-ROM included with your PPC-153. The installation procedure is shown in the next section in this chapter.

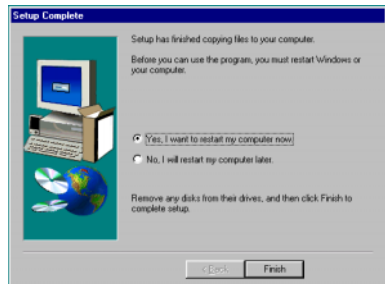
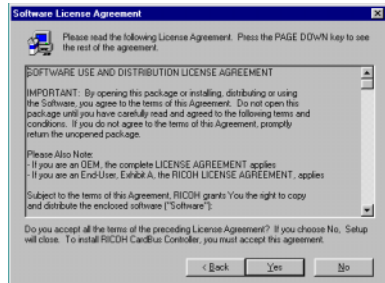
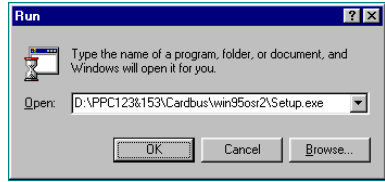
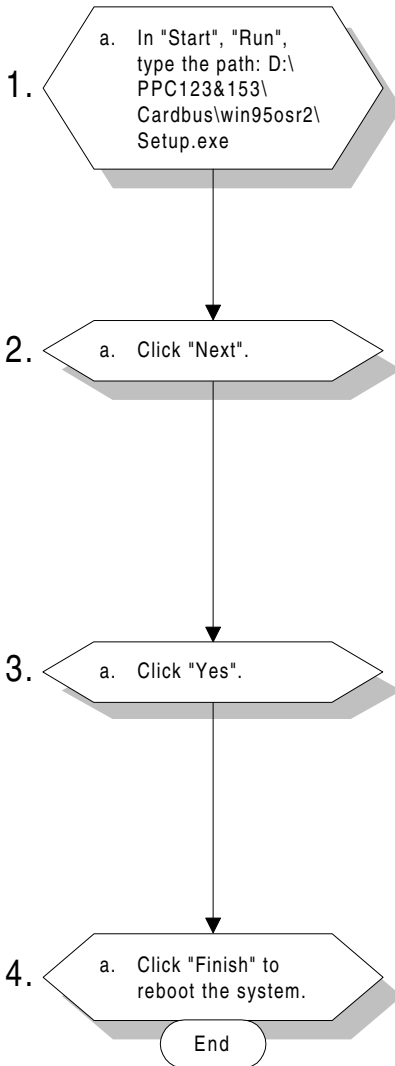
Other operating systems such as Windows 98 and Windows NT also support PCMCIA drivers. However, the drivers for these operating systems are not included in the "Drivers and Utilities" CD-ROM. Installation for these operating systems is not explained in this manual.

*Important: The following windows illustrations are examples only. You must follow the flow chart instructions and pay attention to the instructions which then appear on your screen.*

*Note 1: The CD-ROM drive is designated as "D" throughout this chapter.*

*Note 2: <Enter> means pressing the "Enter" key on the keyboard.*

## 10.2.1 Installation for Windows 95





# CHAPTER 11

## Touchscreen

- Introduction
- Installation of Driver for Resistive or SAW Touchscreen
  - for Windows 95
  - for Windows 98
  - for Windows NT
  - for Windows 2000
  - for Windows ME
- Installation of Driver for Capacitive Touchscreen
  - for Windows 95/98/NT

# 11.1 Introduction

---

## 11.1.1 General information

The PPC-153's optional touchscreen incorporates advanced second-generation 5-wire resistive, impact-resistant capacitive, or surface acoustic wave (SAW) technology. They allow 75%, 85%, and 91% light transmission respectively. The resistive and capacitive models have an antiglare surface, but the SAW model does not. All models provide greatly enhanced visual resolution. They also have new improved scratch-resistant features.

The touchscreen is manufactured from UL-recognized components. When properly installed, the touchscreen's ball impact resistance meets the UL 1950 standard. Its fire resistance meets the UL-746C, 19 mm (0.75") flame test standard. Systems incorporating the touchscreen, controllers, and cables have been approved to FCC Class A and Class B standards.

For more detailed information, please visit the following websites:

Resistive and SAW models: [www.elotouch.com](http://www.elotouch.com)

Capacitive model: [www.microtouch.com](http://www.microtouch.com)

## 11.1.2 General specifications

Please refer to Chapter 1, Section 1.3 of this manual.

## 11.1.3 Environmental specifications

**Temperature:** -10° ~ 50° C (operating)  
-40° ~ 71° C (storage)

**Relative humidity:**  
90 RH at 35° C (operating)  
90 RH at 35° C for 240 hours, non-condensing (storage)

**Chemical resistance:** The active area of the touchscreen is resistant to the following chemicals when exposed for a period of one hour at a temperature of 21° C (71° F):

- Acetone
- Methylene chloride
- Methyl ethyl ketone
- Isopropyl alcohol
- Hexane
- Ammonia-based glass cleaners
- Turpentine
- Mineral spirits
- Foods and beverages

## 11.2 Installation of Driver for Resistive or SAW Touchscreen

---

The touchscreen driver for Windows 95/98 contains a native, 32-bit driver and a 32-bit control panel program for the PPC-153 system.

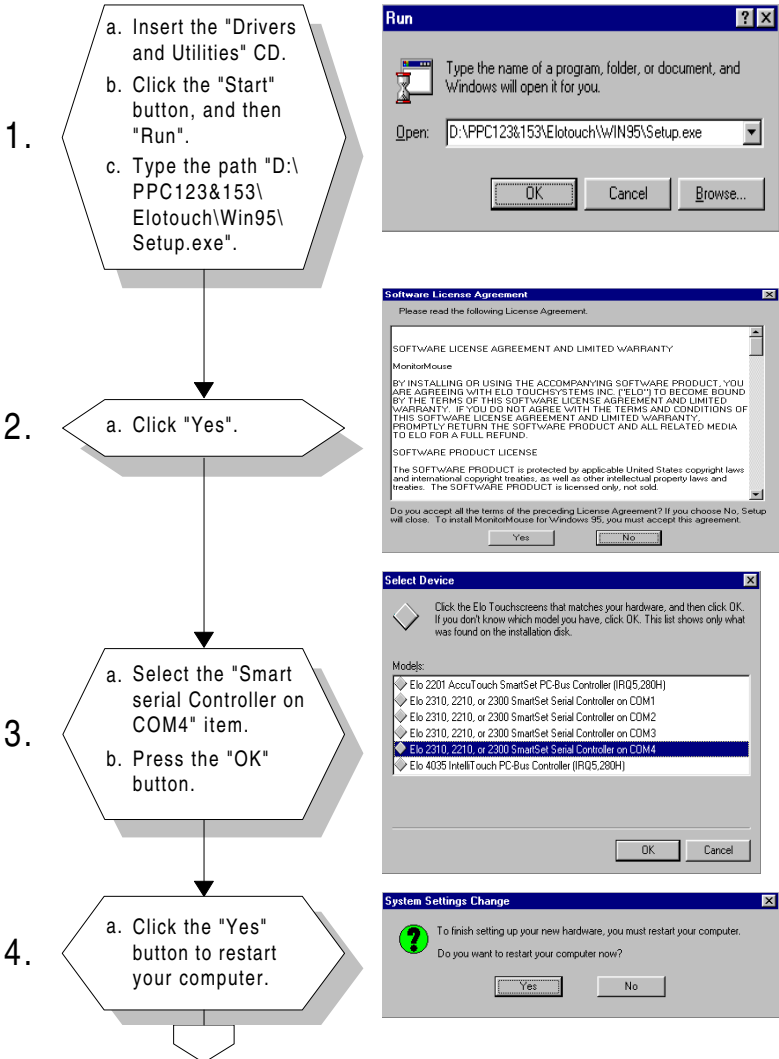
To facilitate installation of the touchscreen driver, you should read the instructions in this section carefully before you attempt installation.

*Important:* The following windows illustrations are examples only. You must follow the flow chart instructions and pay attention to the instructions which then appear on your screen.

*Note 1:* The CD-ROM drive is designated as "D" throughout this chapter.

*Note 2:* <Enter> means pressing the "Enter" key on the keyboard.

## 11.2.1 Installation for Windows 95





5.

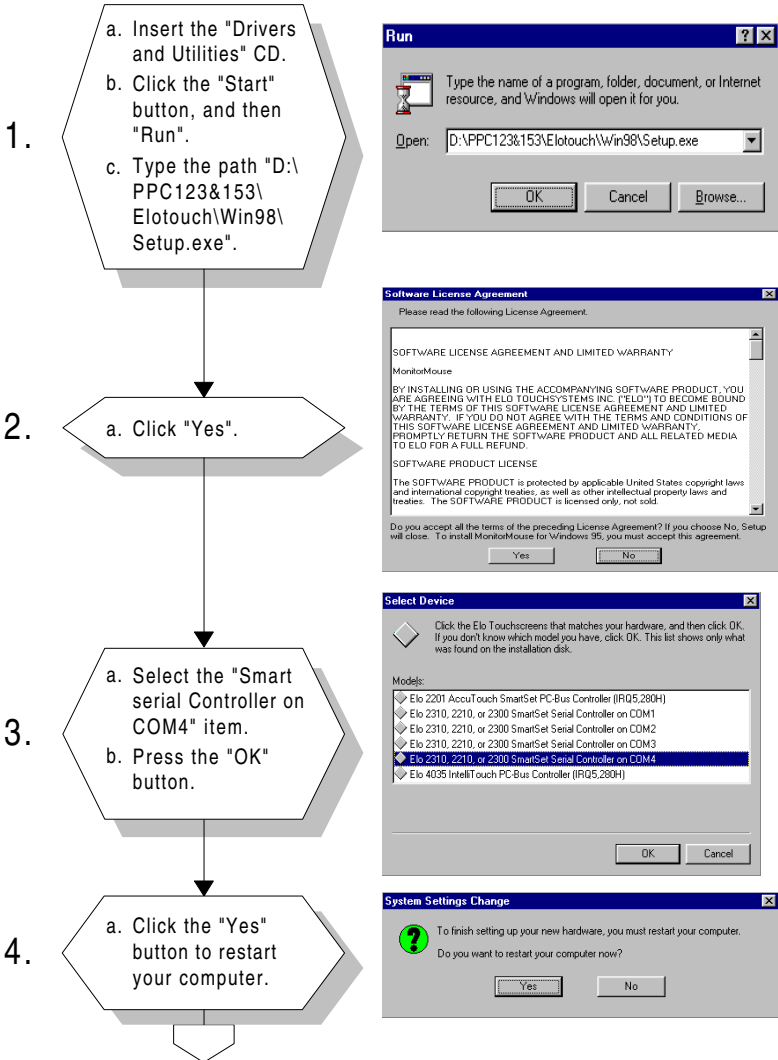
a. Touch targets to calibrate the touchscreen controller.

End



## 11.2.2 Installation for Windows 98

If you want to use the touchscreen driver CD-ROM accompanying your panel PC, refer to the following flow chart instructions.



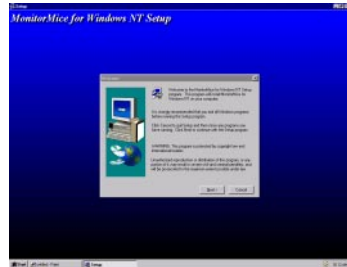
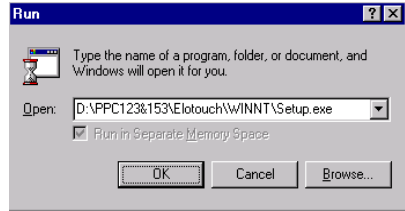
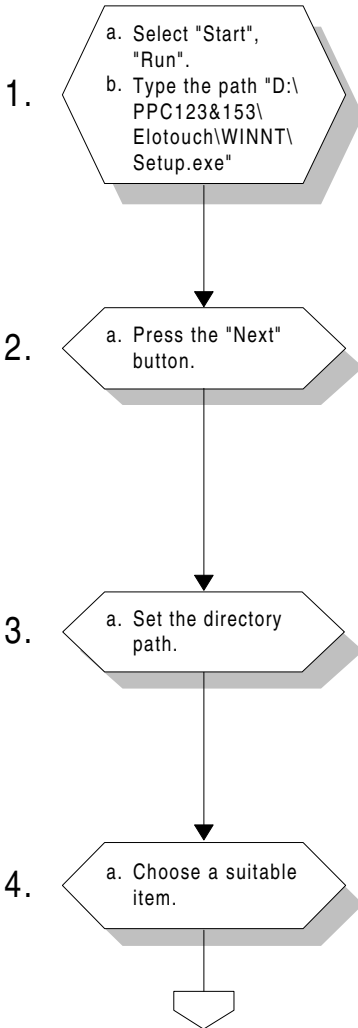
5.

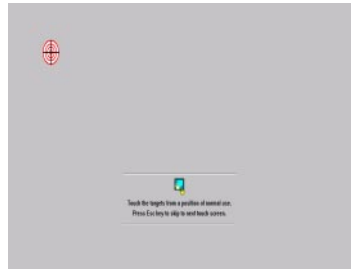
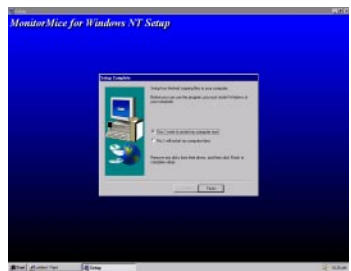
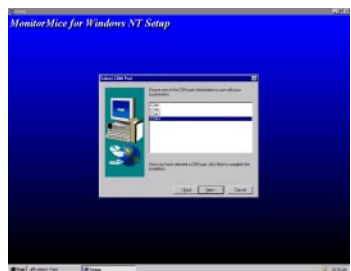
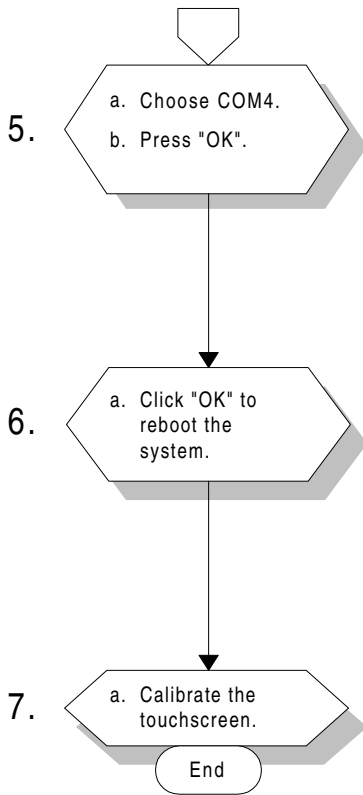
a. Touch targets to calibrate the touchscreen controller.

End

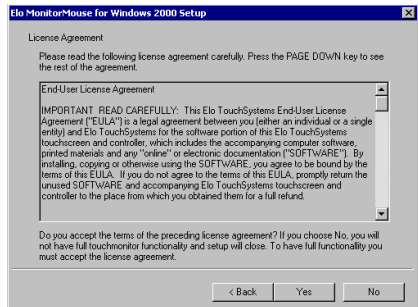
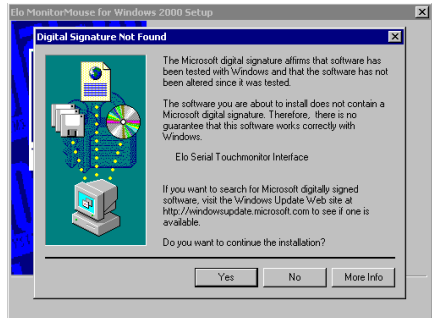
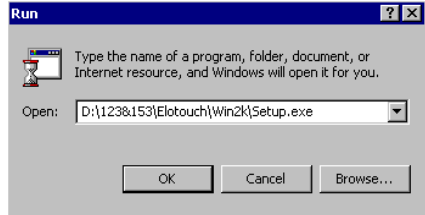
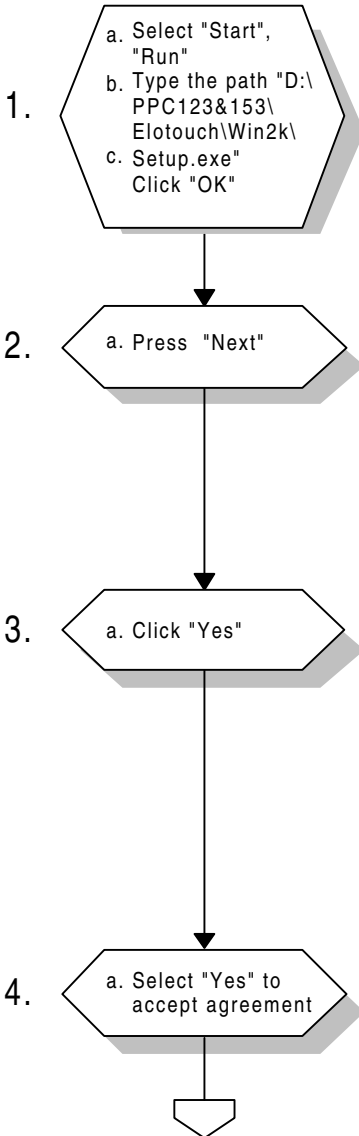


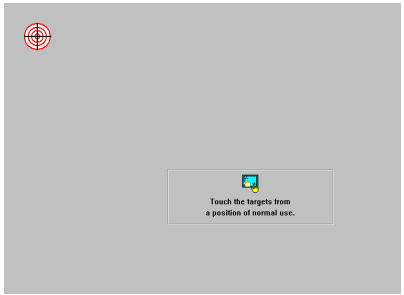
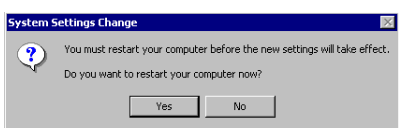
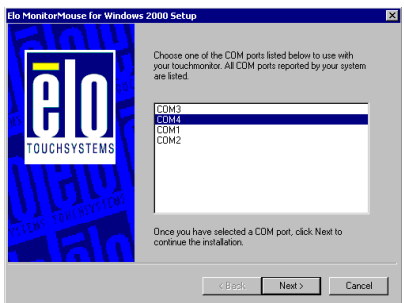
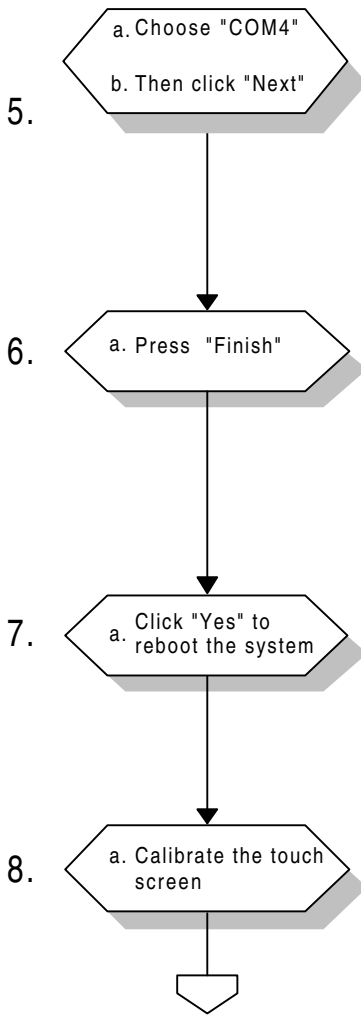
## 11.2.3 Installation for Windows NT

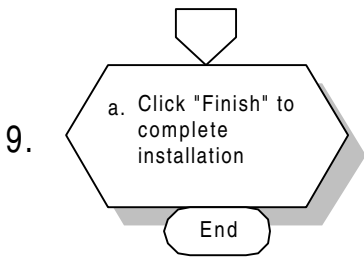




## 11.2.4 Intallation for Windows 2000

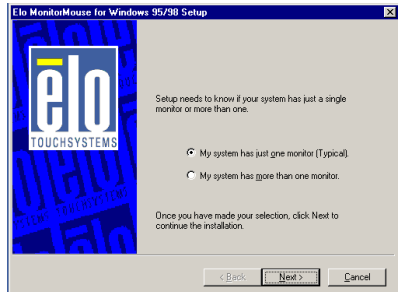
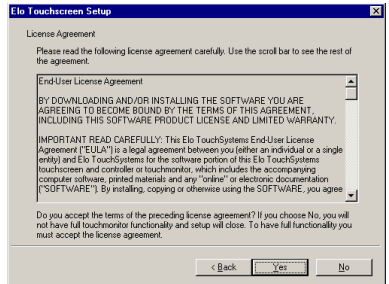
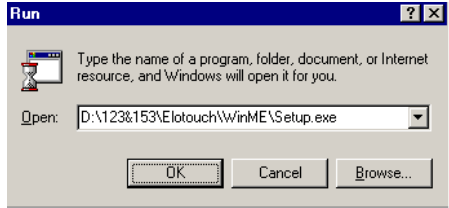
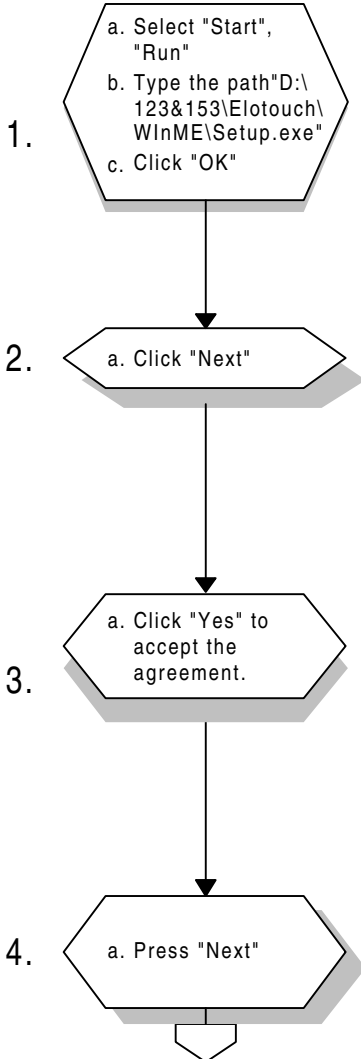


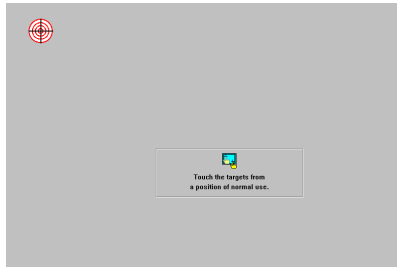
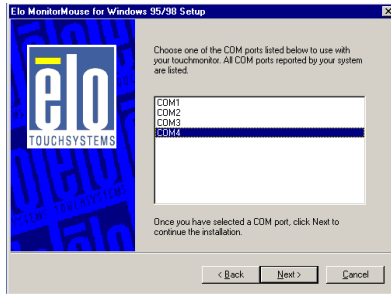
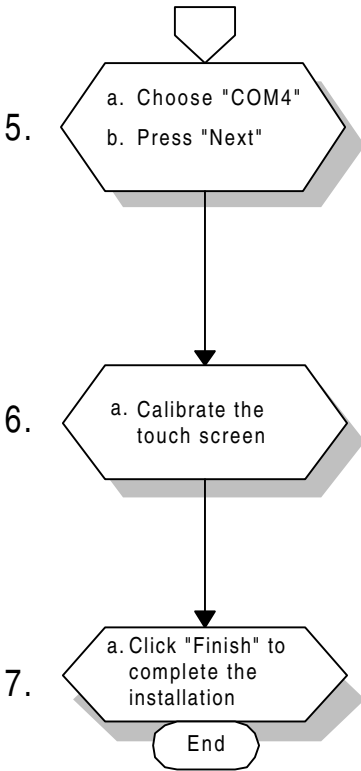






## 11.2.5 Installation for Windows ME





## 11.3 Installation of Driver for Capacitive Touchscreen

---

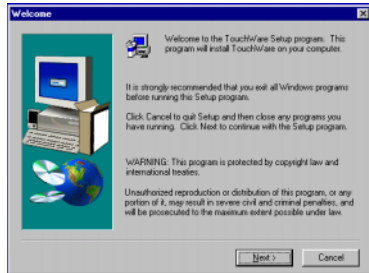
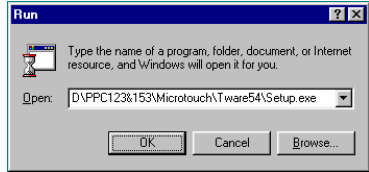
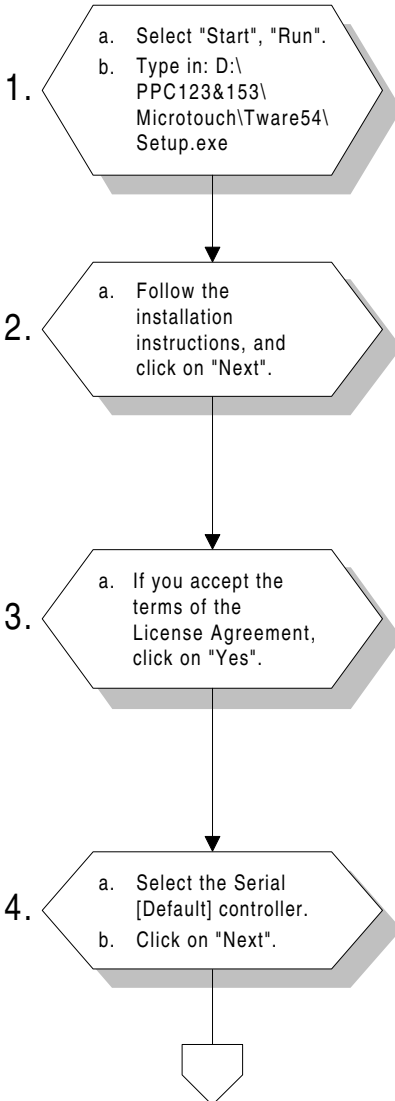
To facilitate installation of the touchscreen driver, you should read the instructions in this chapter carefully before you attempt installation.

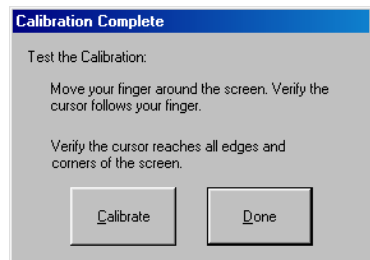
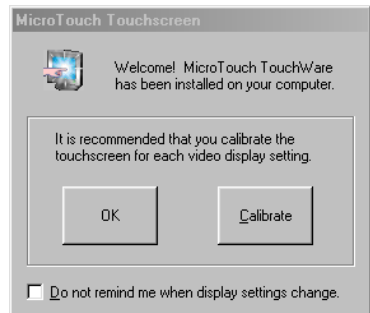
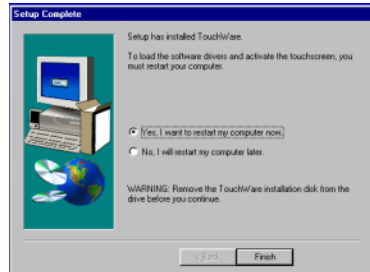
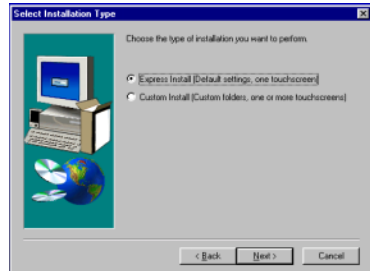
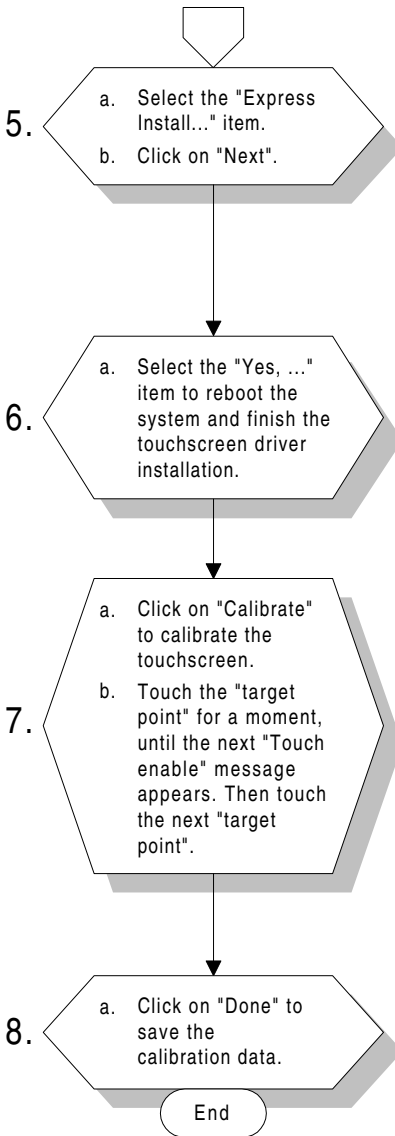
*Important:* The following windows illustrations are examples only. You must follow the flow chart instructions and pay attention to the instructions which then appear on your screen.

*Note 1:* The CD-ROM drive is designated as "D" throughout this chapter.

*Note 2:* <Enter> means pressing the "Enter" key on the keyboard.

### 11.3.1 Installation for Windows 95/98/NT







**APPENDIX  
A**

**LCD Specifications and  
Selection Settings**

## A.1 PPC-153T LCD Specifications

---

**Display type:** 15" TFTLCD

**Max. resolution:** 1024 x 768

**Colors:** 256 K or above

**Dot size (mm):** 0.297 x 0.297

**Viewing angle:** 120°

**Luminance:** 200 cd/m<sup>2</sup>

**Temperature:** 0 ~ 50° C

**\*VR control:** Brightness

**Simultaneous mode:** Yes

**LCD MTBF:** 50,000 hours

**Backlight MTBF:** 25,000 hours

\* The VR control knob is located in the I/O section on the rear side of the panel PC.

*Note: The color LCD display installed in the panel PC is high-quality and reliable. However, it may contain a few defective pixels which do not always illuminate. With current technology, it is impossible to completely eliminate defective pixels. Advantech is actively working to improve this technology.*



## **Programming the Watchdog Timer**

The PPC-153 is equipped with a watchdog timer that resets the CPU or generates an interrupt if processing comes to a standstill for any reason. This feature ensures system reliability in industrial standalone or unmanned environments.

## B.1 Programming the Watchdog Timer

---

To program the watchdog timer, you must write a program which writes I/O port address 443 (hex). The output data is a time interval value. The value range is from 01 (hex) to 3E (hex), and the related time interval is from 1 sec. to 62 sec.

<b>Data</b>	<b>Time Interval</b>
01	1 sec.
02	2 sec.
03	3 sec.
04	4 sec.
•	•
•	•
•	•
3E	62 sec.

After data entry, your program must refresh the watchdog timer by rewriting the I/O port 443 (hex) while simultaneously setting it. When you want to disable the watchdog timer, your program should read I/O port 443 (hex).

The following example shows how you might program the watchdog timer in BASIC:

```
10      REM   Watchdog timer example program
20      OUT &H443, data REM   Start and restart the
      watchdog
30      GOSUB 1000 REM   Your application task #1,
40      OUT &H443, data REM   Reset the timer
50      GOSUB 2000 REM   Your application task #2,
60      OUT &H443, data REM   Reset the timer
70      X=INP (&H443) REM, Disable the watchdog timer
80      END

1000    REM   Subroutine #1, your application task
      •
      •
      •
1070    RETURN
2000    REM   Subroutine #2, your application task
      •
      •
      •
2090    RETURN
```



**APPENDIX**

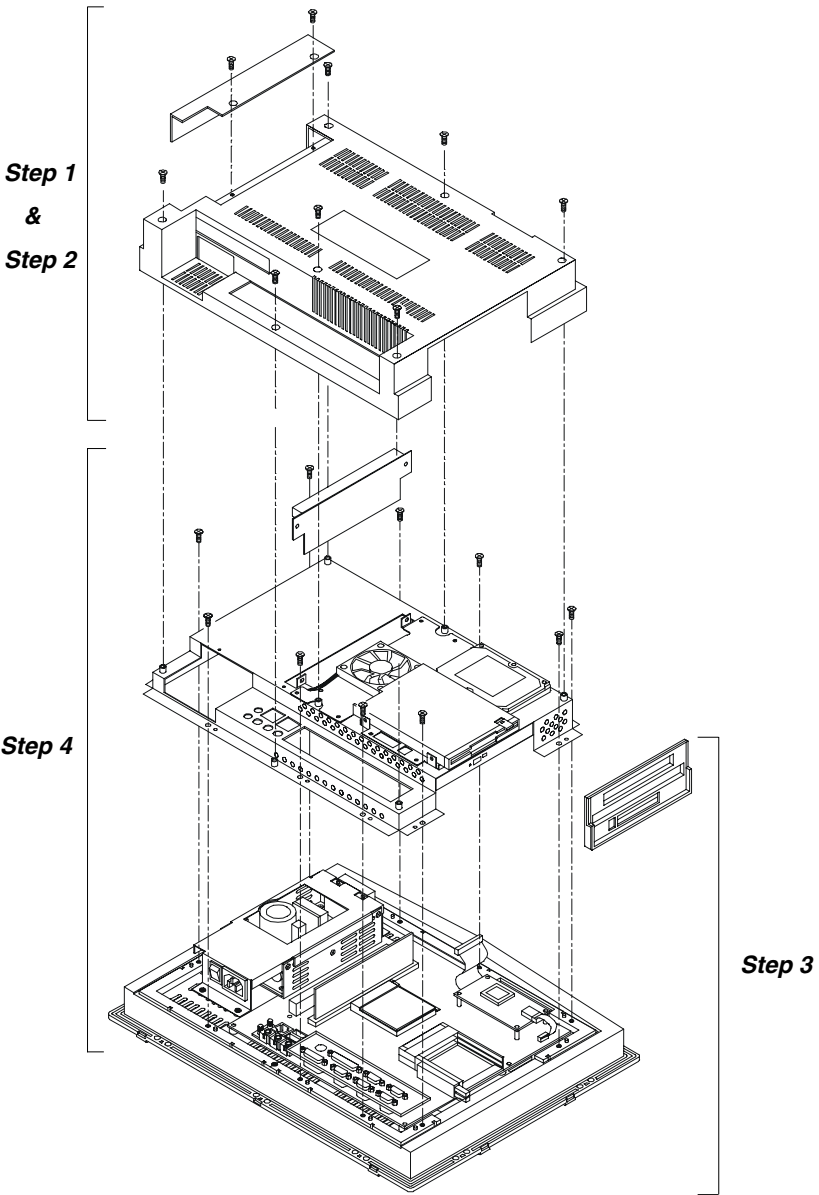
**C**

**Full Disassembly  
Procedures**

If you want to completely disassemble the panel PC, follow the step-by-step procedures below. Users should be aware that Advantech Co., Ltd. takes no responsibility whatsoever for any problems or damage caused by the user disassembly of the panel PC. Make sure the power cord of the panel PC is unplugged before you start disassembly.

The following procedures do not include the detailed disassembly procedures for the CPU, HDD, CD-ROM drive, FDD, and SRAM; all of which can be found in Chapter 4.

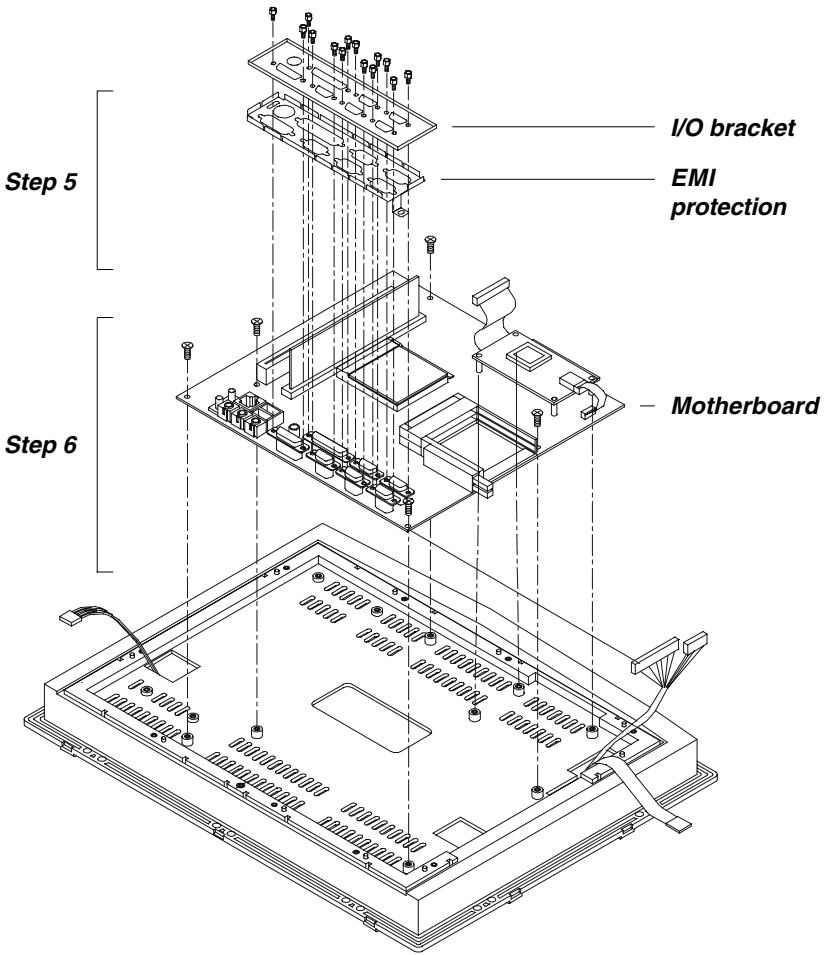
1. Unscrew the seven screws on the rear cover, and remove it. The PCI/ISA expansion slot cover can be detached by removing the two additional screws.
2. Remove the side panel by pushing it outward.
3. Unscrew the four screws that attach the CPU cover.
4. Detach the flat cable of the HDD, FDD and CD-ROM drive. Remove the two screws on the PCI/ISA bus expansion card. Remove the ten screws on the side rim of the shielding case. Carefully move the shielding case to the right to bypass the eject buttons of the PCMCIA slot, before removing the case from the machine.



**Figure C-1: Disassembly steps 1 - 4**

5. Unscrew the fourteen screws of the I/O bracket with a hexagonal screwdriver. The EMI protection cover lies below the I/O bracket. You can now remove both the bracket and the cover from the I/O ports.
6. Detach the flat cables of the LCD inverter, touchscreen and LCD from the motherboard. You can remove the motherboard from the plastic housing.

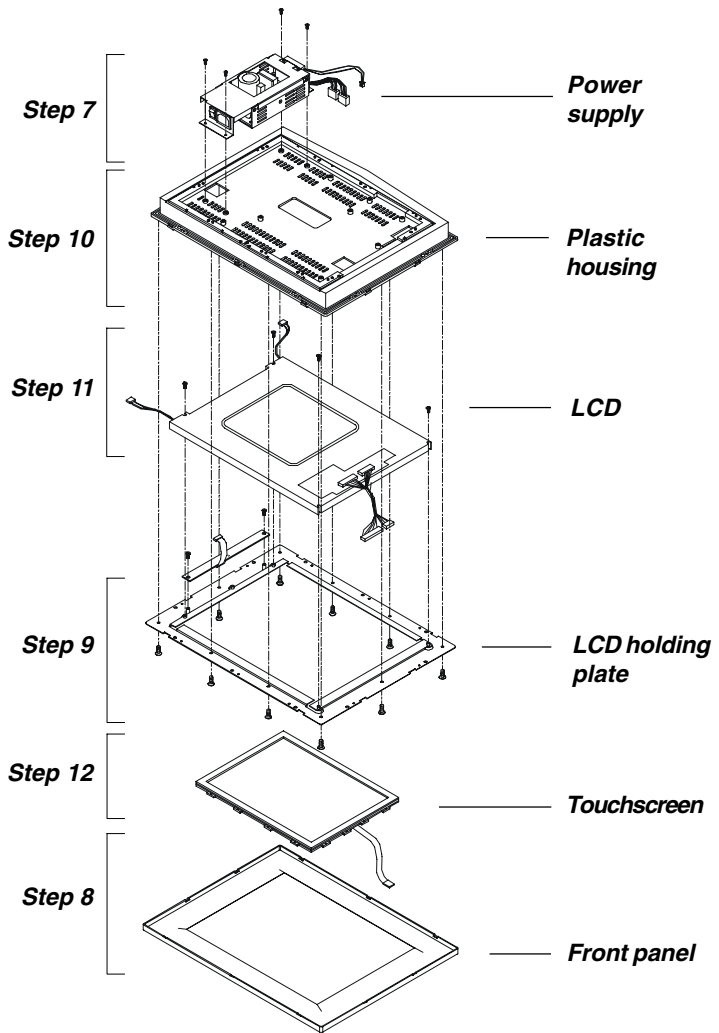




**Figure C-2: Disassembly steps 5 - 6**

7. Unscrew the four screws on the power supply board. The power supply board can be detached from the plastic housing after unplugging the cables from the motherboard.
8. Remove the front panel by hand.
9. Unscrew the ten screws on the LCD holding plate to separate the plastic housing and LCD holding plate. The LCD inverter can also be detached by unscrewing the three screws at the bottom (Toshiba LCD only).
10. Detach the plastic housing.
11. Detach the LCD by unscrewing the four screws located on the each corners.
12. The touchscreen is stuck on the LCD holding plate by a strongly double-side adhesive tape. We do not recommend you to remove it unless the touchscreen is defective and you would like to replace it.

*Note: Because of the modular design of the LCD and touchscreen, you do not disassemble the whole system step by step if you would like to replace the defective LCD or touchscreen. You just start disassembling the module from the step 8. Then you can easily remove the LCD and touchscreen by step 9 to step 12.*



**Figure C-3: Disassembly steps 7 - 12**



# APPENDIX **D**

## Pin Assignments

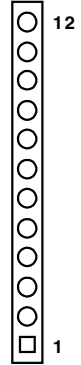
- AT Power Connector (J1)
- TV Output Connector (J2) (\*Reserved)
- Inverter Power Connector (J4)
- Internal Speaker Connector (J6) (Reserved)
- Front Panel Control Connector (J8) (Reserved)
- IR Connector (J9) (Reserved)
- Flat Panel Display Connector (CN2)
- Flat Panel Display Connector (CN3)
- PanelLink Interface (CN4) (Reserved)
- Floppy Drive Connector (CN10)
- EIDE Hard Disk Drive Connector (CN16)
- CD-ROM Connector (CN18)
- CPU Fan Power Connector (FAN1)
- System Fan Power Connector (FAN2)
- PCI/ISA Expansion Connector (SLOT1)
- Internal COM4 and PS/2 connector (CN23)
- COM2

## D.1 AT Power Connector (J1)

---

Table D-1: AT power connector (J1)

Pin	Signal
1	PS_NO #
2	+5 VSB
3	+12 V
4	-12 V
5	GND
6	GND
7	GND
8	GND
9	-5 V
10	+5 V
11	+5 V
12	+5 V

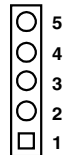


## D.2 TV Output Connector (J2) (\*Reserved)

---

Table D-2: TV output connector (J2)

Pin	Signal
1	Y
2	C
3	GND
4	GND
5	CVBS



## D.3 Inverter Power Connector (J4)

---

Table D-3: Inverter power connector (J4)

Pin	Signal
1	+12 V
2	GND
3	ENABKL
4	Brightness Adj.
5	+5 V



## D.4 Internal Speaker Connector (J6) (\*Reserved)

---

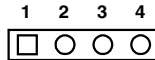


Table D-4: Internal speaker connector (J6)

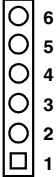
Pin	Signal
1	Speaker out_R -
2	Speaker out_R +
3	Speaker out_L +
4	Speaker out_L -

## D.5 Front Panel Control Connector (J8) (\*Reserved)

---

Table D-5: Front panel control connector (J8) (\*Reserved)

Pin	Signal
1	Vcc
2	GND
3	HDD LED
4	Reset SW
5	Power SW
6	NC



## D.6 IR Connector (J9) (\*Reserved)

---

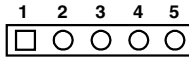


Table D-6: IR connector (J9) (Reserved)

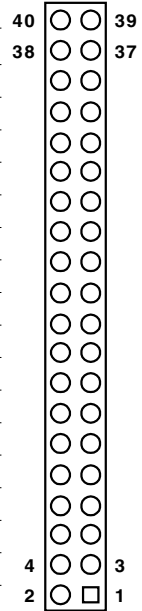
Pin	Signal
1	$V_{CC}$
2	NC
3	IR_IN
4	GND
5	IR_OUT



## D.7 Flat Panel Display Connector (CN2)

Table D-7: Flat panel display connector (CN2)

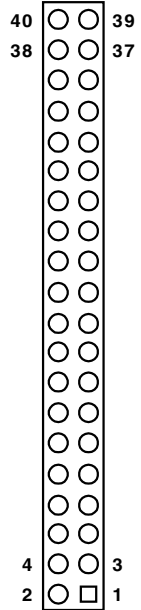
Pin	Signal	Pin	Signal
1	VDDSAFE5	2	VDDSAFE5
3	GND	4	GND
5	VDDSAFE3	6	VDDSAFE3
7	Vcon	8	GND
9	P0	10	P1
11	P2	12	P3
13	P4	14	P5
15	P6	16	P7
17	P8	18	P9
19	P10	20	P11
21	P12	22	P13
23	P14	24	P15
25	P16	26	P17
27	P18	28	P19
29	P20	30	P21
31	P22	32	P23
33	GND	34	GND
35	SHFCLK	36	FLM
37	M/DE	38	LP
39	ENABKL	40	ENAVEE



# D.8 Flat Panel Display Connector (CN3)

Table D-8: Flat panel display connector (CN3)

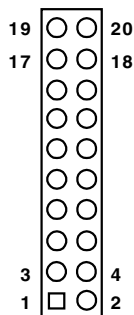
Pin	Signal	Pin	Signal
1	VDDSAFE5	2	VDDSAFE5
3	GND	4	GND
5	VDDSAFE3	6	VDDSAFE3
7	Vcon	8	GND
9	P24	10	P25
11	P26	12	P27
13	P28	14	P29
15	P30	16	P31
17	P32	18	P33
19	P34	20	P35
21	NC	22	NC
23	NC	24	NC
25	NC	26	NC
27	NC	28	NC
29	NC	30	NC
31	NC	32	NC
33	GND	34	GND
35	SHFCLK	36	FLM
37	M/DE	38	LP
39	ENABKL	40	ENAVEE



## D.9 PanelLink Interface (CN4) (\*Reserved)

Table D-9: PanelLink Interface (CN4) (\*Reserved)

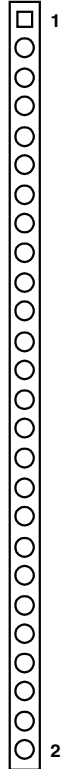
Pin	Signal	Pin	Signal
1	TXC-	11	TX1+
2	GND	12	NC
3	TXC+	13	TX2-
4	GND	14	NC
5	TX0-	15	TX2+
6	GND	16	EDGE
7	TX0+	17	2NDSDA
8	GND	18	Vcc
9	TX1-	19	2NDSCL
10	NC	20	GND



# D.10 Floppy Drive Connector (CN10)

Table D-10: Floppy drive connector (CN10)

Pin	Signal	Pin	Signal
1	$V_{cc}$ (+5 V)	14	STEP
2	INDEX	15	GND
3	$V_{cc}$ (+5 V)	16	WRITE ENABLE
4	DRIVE SELECT	17	GND
5	$V_{cc}$ (+5 V)	18	WRITE DATA
6	DISK CHANGE	19	GND
7	NC	20	TRACK 0
8	NC	21	GND
9	NC	22	WRITE PROTECT
10	MOTOR ON	23	GND
11	NC	24	READ DATA
12	DIRECTION	25	GND
13	DENSITY SELECT	26	SIDE 1 SELECT



## D.11 EIDE Hard Disk Drive Connector (CN16)

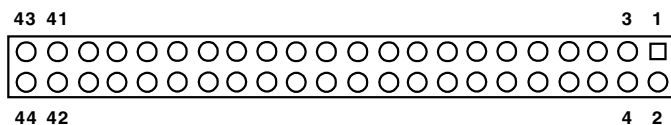


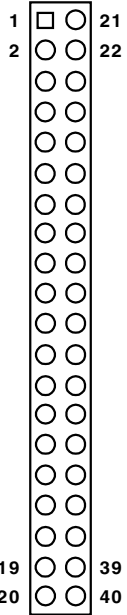
Table D-11: EIDE hard disk drive connector (CN16)

Pin	Signal	Pin	Signal
1	IDE RESET #	2	GND
3	DATA 7	4	DATA 8
5	DATA 6	6	DATA 9
7	DATA 5	8	DATA 10
9	DATA 4	10	DATA 11
11	DATA 3	12	DATA 12
13	DATA 2	14	DATA 13
15	DATA 1	16	DATA 14
17	DATA 0	18	DATA 15
19	SIGNAL GND	20	N/C
21	HDD DREQ	22	GND
23	IO WRITE	24	GND
25	IO READ	26	GND
27	HD READY	28	CABLE SELECT
29	HDACK 0 #	30	GND
31	IRQ14	32	N/C
33	ADDR 1	34	N/C
35	ADDR 0	36	ADDR 2
37	HDD SELECT 0 #	38	HDD SELECT 1 #
39	IDE ACTIVE 0 #	40	GND
41	V <sub>cc</sub>	42	V <sub>cc</sub>
43	GND	44	N/C

# low active

# D.12 CD-ROM Connector (CN18)

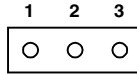
Table D-12: CD-ROM connector (CN18)			
Pin	Signal	Pin	Signal
1	Audio_L	2	Audio_R
3	GND	4	GND
5	IDE RESET #	6	DATA8
7	DATA7	8	DATA9
9	DATA6	10	DATA10
11	DATA5	12	DATA11
13	DATA4	14	DATA12
15	DATA3	16	DATA13
17	DATA2	18	DATA14
19	DATA1	20	DATA15
21	DATA0	22	HDD DREQ
23	GND	24	IO READ
25	IO WRITE	26	GND
27	HD READY	28	HD ACK 0 #
29	IRQ 15	30	NC
31	ADDR1	32	NC
33	ADDR0	34	ADDR2
35	HDD SELECT 0 #	36	HDD SELECT 1 #
37	V <sub>cc</sub> (+5 V)	38	V <sub>cc</sub> (+5 V)
39	GND	40	GND



# low active

## D.13 CPU Fan Power Connector (FAN1)

---



---

Table D-13: CPU fan power connector (FAN1)

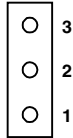
---

Pin	Signal
1	GND
2	+12 V
3	FAN_DET

---

## D.14 System Fan Power Connector (FAN2)

---



---

Table D-14: Fan power connector (FAN2)

---

Pin	Signal
1	GND
2	+12 V
3	FAN_DET

---

# D.15 PCI/ISA Bus Expansion Connector (SLOT1)

*side view*

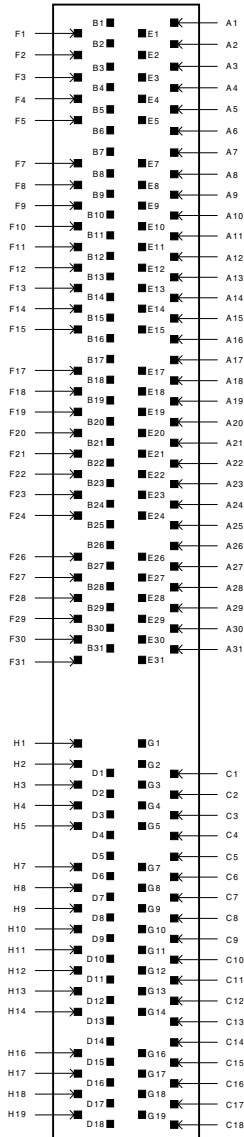




Table D-15: PCI/ISA slot pin assignments (Pins A and B)

<b>Pin</b>	<b>Signal</b>	<b>Pin</b>	<b>Signal</b>
A1	IOCHK	B1	GND
A2	SD7	B2	RST
A3	SD6	B3	V <sub>CC</sub>
A4	SD5	B4	IRQ9
A5	SD4	B5	NC
A6	SD3	B6	DRQ2
A7	SD2	B7	-12 V
A8	SD1	B8	OWS
A9	SD0	B9	+12 V
A10	IORDY	B10	GND
A11	AEN	B11	SMW
A12	SA19	B12	SMR
A13	SA18	B13	IOW
A14	SA17	B14	IOR
A15	SA16	B15	DACK3
A16	SA15	B16	DRQ3
A17	SA14	B17	DACK1
A18	SA13	B18	DRQ1
A19	SA12	B19	REF
A20	SA11	B20	SCLK
A21	SA10	B21	IRQ7
A22	SA9	B22	IRQ6
A23	SA8	B23	IRQ5
A24	SA7	B24	IRQ4
A25	SA6	B25	IRQ3
A26	SA5	B26	DACK2
A27	SA4	B27	TC
A28	SA3	B28	ALE
A29	SA2	B29	V <sub>CC</sub>
A30	SA1	B30	OSC
A31	SA0	B31	GND

Table D-16: PCI/ISA slot pin assignments (Pins C and D)

<b>Pin</b>	<b>Signal</b>	<b>Pin</b>	<b>Signal</b>
C1	SBHE	D1	MEM16
C2	LA23	D2	IO16
C3	LA22	D3	IRQ10
C4	LA21	D4	IRQ11
C5	LA20	D5	IRQ12
C6	LA19	D6	IRQ15
C7	LA18	D7	IRQ14
C8	LA17	D8	DACK0
C9	MEMR	D9	DRQ0
C10	MEMW	D10	DACK5
C11	SD8	D11	DRQ5
C12	SD9	D12	DACK6
C13	SD10	D13	DRQ6
C14	SD11	D14	DACK7
C15	SD12	D15	DRQ7
C16	SD13	D16	V <sub>CC</sub>
C17	SD14	D17	MASTER
C18	SD15	D18	GND

Table D-17: PCI/ISA slot pin assignments (Pins E and F)

<b>Pin</b>	<b>Signal</b>	<b>Pin</b>	<b>Signal</b>
E1	GND	F1	GND
E2	GND	F2	GND
E3	INT 1	F3	INT3
E4	INT 2	F4	INT4
E5	V <sub>CC</sub>	F5	V <sub>CC</sub>
E6	---	F6	---
E7	V <sub>CC</sub>	F7	V <sub>CC</sub>
E8	RST	F8	PCLK2
E9	GNT2	F9	(V)
E10	REQ2	F10	GNT3
E11	GND	F11	GND
E12	PCLK1	F12	REQ3
E13	GND	F13	AD31
E14	AD30	F14	AD29
E15	NC	F15	NC
E16	---	F16	---
E17	NC	F17	NC
E18	AD28	F18	AD27
E19	AD26	F19	AD25
E20	AD24	F20	CBE3
E21	AD22	F21	AD23
E22	AD20	F22	AD21
E23	AD18	F23	AD19
E24	NC	F24	NC
E25	---	F25	---
E26	---	F26	NC
E27	AD16	F27	AD17
E28	FRAME	F28	IRDY
E29	CBE2	F29	DEVSEL
E30	TRDY	F30	LOCK
E31	STOP	F31	PERR

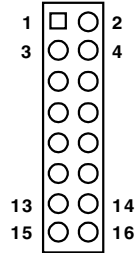
Table D-18: PCI/ISA slot pin assignments (Pins G and H)

<b>Pin</b>	<b>Signal</b>	<b>Pin</b>	<b>Signal</b>
G1	---	H1	SERR
G2	---	H2	AD15
G3	CBE1	H3	AD14
G4	PAR	H4	AD12
G5	GND	H5	GND
G6	---	H6	KEY
G7	GND	H7	GND
G8	AD13	H8	AD10
G9	AD11	H9	AD8
G10	AD9	H10	AD7
G11	CBEO	H11	AD5
G12	AD6	H12	AD3
G13	AD4	H13	AD1
G14	AD2	H14	AD0
G15	---	H15	KEY
G16	V <sub>CC</sub>	H16	V <sub>CC</sub>
G17	V <sub>CC</sub>	H17	V <sub>CC</sub>
G18	GND	H18	GND
G19	GND	H19	GND

## D.16 Touchscreen Connector (CN23)

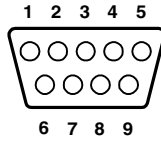
Table D-19: Internal COM4 and PS/2 Connector (CN23)

Pin	Signal	Pin	Signal
1	NRLSD	2	NDSR
3	NRX	4	NRTS
5	NTX	6	NCTS
7	NDTR	8	NRI
9	GND	10	GND
11	MSDAT	12	EXT MSDAT
13	MSCLK	14	EXT MSCLK
15	Vcc	16	Vcc



# D.17 COM2

---



---

Table D-20: COM2

---

Pin	Signal		
	RS-232	RS-422	RS-485
1	DCD	TX-	DATA-
2	RX	TX+	DATA+
3	TX	RX+	---
4	DTR	RX-	---
5	GND	GND	---
6	DSR	---	---
7	RTS	---	---
8	CTS	---	---
9	RI	---	---

---

# APPENDIX **E**

## **Mounting Instructions**

- Introduction
- Panel Mounting
- Desktop Stand Mounting
- Swingarm Stand Mounting

# E.1 Introduction

---

The PPC-153 can be placed as is on a shelf or table, mounted into a panel, or mounted on a customized swingarm or desktop stand.

# E.2 Panel Mounting

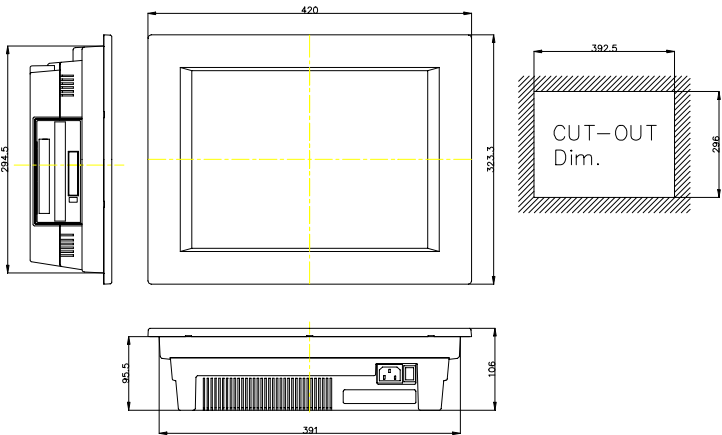
---

## E.2.1 Introduction

Panel mounting can help system integrators conveniently integrate the panel PC into their system.

To construct a suitable panel, refer to the following cutout dimensions diagram.

*Note:* The panel thickness should not exceed 10 mm.



**Figure E-1: Cutout dimensions of the PPC-153**

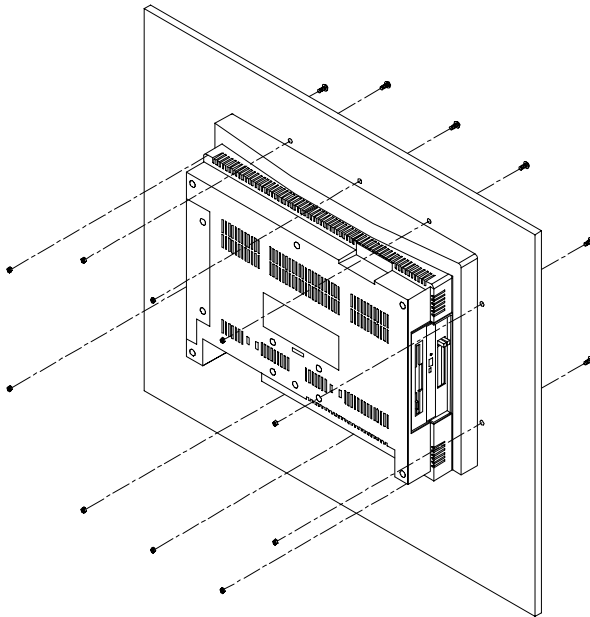


## E.2.2 Installation procedure

To mount the PPC-153 into a panel:

1. Remove the front panel. There are ten holes located along the four sides of the panel PC.
2. Insert the screws from the front side into the holes and tighten them with the nuts provided. (See Fig. E-2)
3. Put the front panel back and make sure it is stable.

*Note:* The panel thickness should not exceed 10 mm.



**Figure E-2: Panel mounting**



## E.3 Desktop Stand Mounting

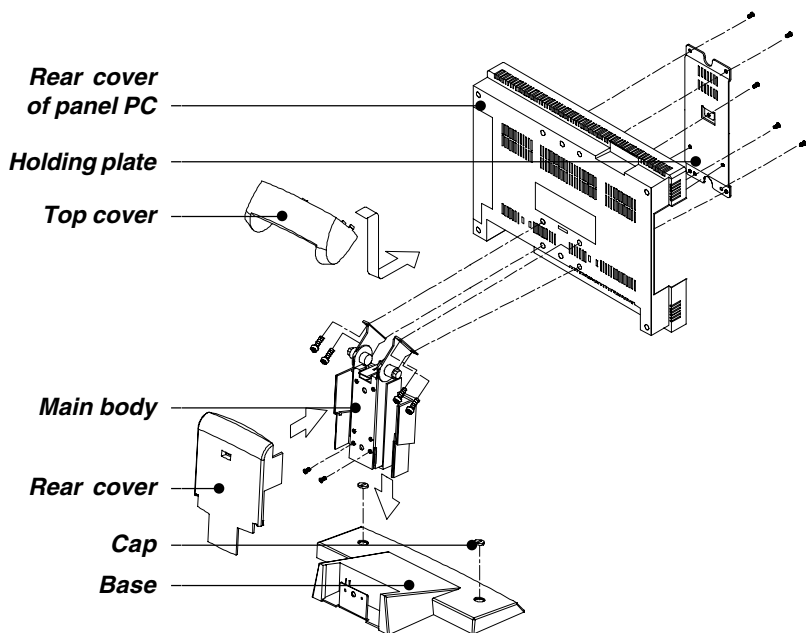
---

The PPC-153 has a customized stand suitable for desktops and other horizontal locations. A unique spring inside the stand enables the panel PC's vertical tilt to be adjusted about 30 degrees. The stand is available from Advantech Co.

Follow these procedures to set up the stand:

1. Remove the rear cover of the panel PC by unscrewing the seven screws.
2. Attach the holding plate of the stand to the inside of the rear cover of the panel PC using the five screws provided. (See Fig. E-4.)
3. Reattach the rear cover of the panel PC.
4. Attach the main body of the stand to the rear cover of the panel PC using the four screws provided.
5. Slide the main body of the stand into the stand base. Tighten it with the two screws provided.
6. Attach the rear cover of the stand to the main body of the stand by snapping the lugs of the rear cover into the slots of the main body. When the rear cover locks into place, you will hear a click.
7. Attach the top cover of the stand to the main body of the stand by snapping the lugs of the top cover into the slots of the main body. The cover must be rotated as it is snapped into place. When the top cover locks into place, you will hear a click.

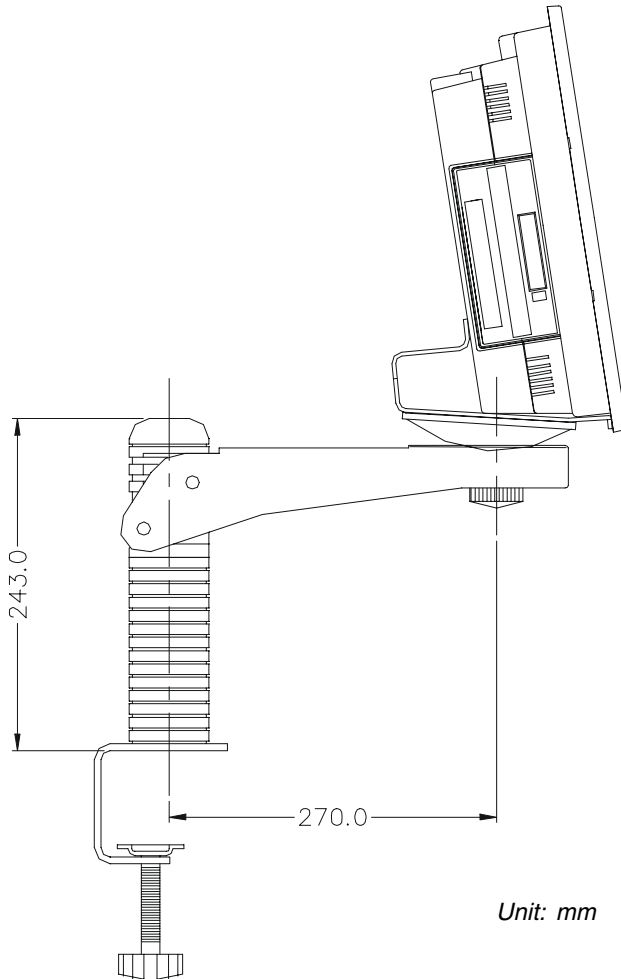
*Note: The base of the stand has two plastic caps. If you pry off the caps, you can attach the stand to your desktop using the two screw holes.*



**Figure E-4: Desktop stand mounting**

## E.4 Swingarm Stand Mounting

The PPC-153 can be mounted on a unique swingarm. This versatile accessory is easy to install and operate, and can be rotated through a wide range of angles. Its dimensions are shown in Figure E-5 below, and it is available from Advantech Co., Ltd.



**Figure E-5: Swingarm stand mounting**

