

PCI-DAS1001

Multifunction Analog and Digital I/O

User's Guide

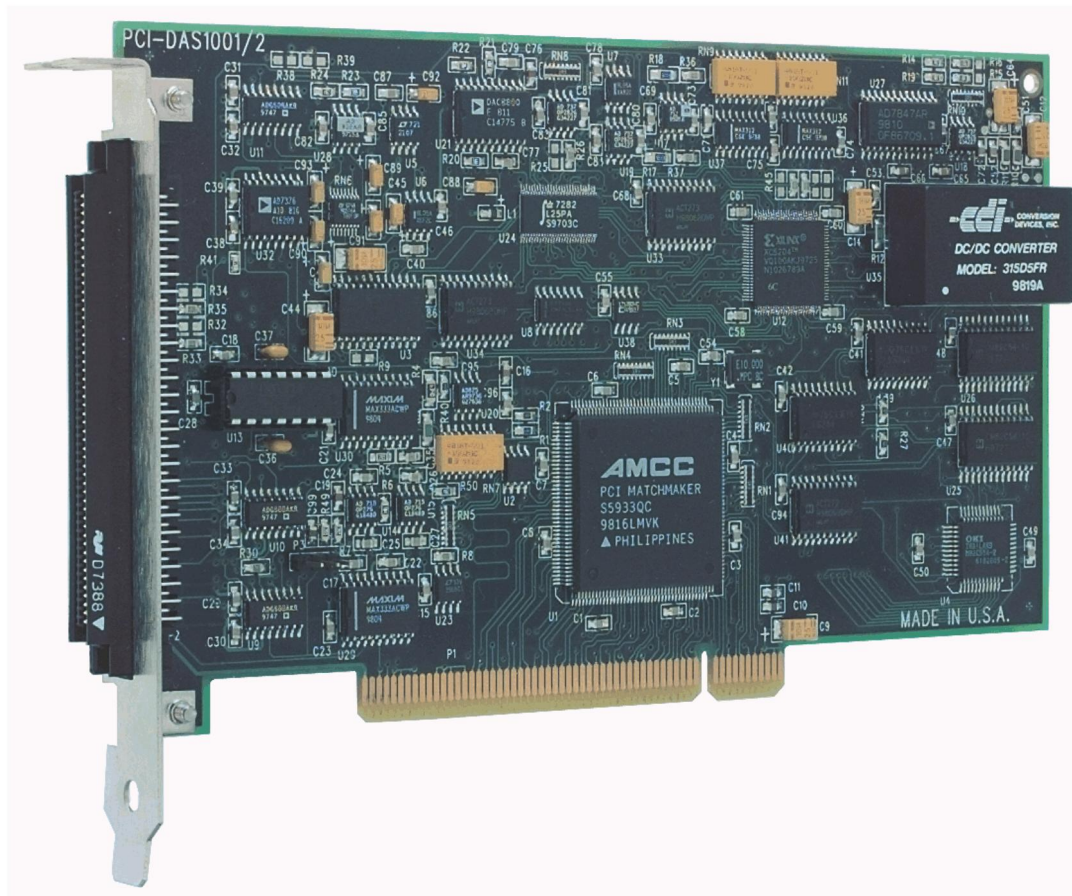

PCI-DAS1001

Multifunction Analog & Digital I/O

User's Guide



**MEASUREMENT
COMPUTING™**

Document Revision 3, March, 2009
© Copyright 2009, Measurement Computing Corporation

Your new Measurement Computing product comes with a fantastic extra —

Management committed to your satisfaction!

Thank you for choosing a Measurement Computing product—and congratulations! You own the finest, and you can now enjoy the protection of the most comprehensive warranties and unmatched phone tech support. It's the embodiment of our mission:

- To provide PC-based data acquisition hardware and software that will save time and save money.

Simple installations minimize the time between setting up your system and actually making measurements. We offer quick and simple access to outstanding live FREE technical support to help integrate MCC products into a DAQ system.

Limited Lifetime Warranty: Most MCC products are covered by a limited lifetime warranty against defects in materials or workmanship for the life of the product, to the original purchaser, unless otherwise noted. Any products found to be defective in material or workmanship will be repaired, replaced with same or similar device, or refunded at MCC's discretion. For specific information, please refer to the terms and conditions of sale.

Harsh Environment Program: Any Measurement Computing product that is damaged due to misuse, or any reason, may be eligible for replacement with the same or similar device for 50% of the current list price. I/O boards face some harsh environments, some harsher than the boards are designed to withstand. Contact MCC to determine your product's eligibility for this program.

30 Day Money-Back Guarantee: Any Measurement Computing Corporation product may be returned within 30 days of purchase for a full refund of the price paid for the product being returned. If you are not satisfied, or chose the wrong product by mistake, you do not have to keep it.

These warranties are in lieu of all other warranties, expressed or implied, including any implied warranty of merchantability or fitness for a particular application. The remedies provided herein are the buyer's sole and exclusive remedies. Neither Measurement Computing Corporation, nor its employees shall be liable for any direct or indirect, special, incidental or consequential damage arising from the use of its products, even if Measurement Computing Corporation has been notified in advance of the possibility of such damages.

Trademark and Copyright Information

TracerDAQ, Universal Library, Measurement Computing Corporation, and the Measurement Computing logo are either trademarks or registered trademarks of Measurement Computing Corporation.

Windows, Microsoft, and Visual Studio are either trademarks or registered trademarks of Microsoft Corporation

LabVIEW is a trademark of National Instruments.

CompactFlash is a registered trademark of SanDisk Corporation.

XBee and XBee-PRO are trademarks of MaxStream, Inc.

All other trademarks are the property of their respective owners.

Information furnished by Measurement Computing Corporation is believed to be accurate and reliable. However, no responsibility is assumed by Measurement Computing Corporation neither for its use; nor for any infringements of patents or other rights of third parties, which may result from its use. No license is granted by implication or otherwise under any patent or copyrights of Measurement Computing Corporation.

All rights reserved. No part of this publication may be reproduced, stored in a retrieval system, or transmitted, in any form by any means, electronic, mechanical, by photocopying, recording, or otherwise without the prior written permission of Measurement Computing Corporation.

Notice

Measurement Computing Corporation does not authorize any Measurement Computing Corporation product for use in life support systems and/or devices without prior written consent from Measurement Computing Corporation. Life support devices/systems are devices or systems which, a) are intended for surgical implantation into the body, or b) support or sustain life and whose failure to perform can be reasonably expected to result in injury. Measurement Computing Corporation products are not designed with the components required, and are not subject to the testing required to ensure a level of reliability suitable for the treatment and diagnosis of people.

Table of Contents

Preface

About this User's Guide	5
What you will learn from this user's guide	5
Conventions in this user's guide	5
Where to find more information	5
Register-level programming	6

Chapter 1

Introducing the PCI-DAS1001	7
Overview: PCI-DAS1001 features	7
Software features	7
PCI-DAS1001 block diagram.....	8

Chapter 2

Installing the PCI-DAS1001	9
What is included with your PCI-DAS1001	9
Hardware	9
Additional documentation.....	9
Optional components	9
Unpacking the PCI-DAS1001	10
Installing the software	10
Installing the hardware	10
Configuring the hardware	10
Differential input mode.....	11
Single-ended input mode	11
Connecting the board for I/O operations	11
Connectors, cables – main I/O connector.....	11
Pinout – main I/O connector	12
Cables	14
Field wiring and signal termination	14

Chapter 3

Calibrating the Board.....	15
Introduction	15
Calibration theory	15

Chapter 4

Specifications	16
Analog input	16
Analog output	17
Digital input/output.....	17
Counter section	18
Power consumption	18
Main connector and pin out	19
8-channel differential mode pin out	20
16-channel single-ended mode pin out.....	21

Declaration of Conformity.....	22
---------------------------------------	-----------

About this User's Guide

What you will learn from this user's guide

This user's guide explains how to install, configure, and use the PCI-DAS1001 so that you get the most out of its analog, digital, and timing I/O features.

This user's guide also refers you to related documents available on our web site, and to technical support resources that can also help you get the most out of your board.

Conventions in this user's guide

For more information on ...

Text presented in a box signifies additional information and helpful hints related to the subject matter you are reading.

Caution! Shaded caution statements present information to help you avoid injuring yourself and others, damaging your hardware, or losing your data.

<#:#> Angle brackets that enclose numbers separated by a colon signify a range of numbers, such as those assigned to registers, bit settings, etc.

bold text **Bold** text is used for the names of objects on the screen, such as buttons, text boxes, and check boxes. For example:
1. Insert the disk or CD and click the **OK** button.

italic text *Italic* text is used for the names of manuals and help topic titles, and to emphasize a word or phrase. For example:
The *InstaCal*® installation procedure is explained in the *Quick Start Guide*.
Never touch the exposed pins or circuit connections on the board.

Where to find more information

The following electronic documents provide relevant information to the operation of your PCI-DAS1001.

- MCC's *Specifications: PCI-DAS1001* (the PDF version of the *Specifications* chapter in this guide) is available on our web site at www.mccdaq.com/pdfs/Specs/PCI-DAS1001-spec.pdf.
- MCC's *Quick Start Guide* is available on our web site at www.mccdaq.com/PDFmanuals/DAQ-Software-Quick-Start.pdf.
- MCC's *Guide to Signal Connections* is available on our web site at www.mccdaq.com/signals/signals.pdf.
- MCC's *Universal Library User's Guide* is available on our web site at www.mccdaq.com/PDFmanuals/sm-ul-user-guide.pdf.
- MCC's *Universal Library Function Reference* is available on our web site at www.mccdaq.com/PDFmanuals/sm-ul-functions.pdf.
- MCC's *Universal Library for LabVIEW™ User's Guide* is available on our web site at www.mccdaq.com/PDFmanuals/SM-UL-LabVIEW.pdf.

PCI-DAS1001 User's Manual (this document) is also available on our web site at www.mccdaq.com/PDFmanuals/PCI-DAS1001.pdf.

Register-level programming

You should use the Universal Library to control your board. Only experienced programmers should perform register-level programming.

If you need to program at the register level in your application, refer to the *Register Map for the PCI-DAS1001 Series* (available at www.mccdaq.com/registermaps/RegMapSTC1000.pdf).

Introducing the PCI-DAS1001

Overview: PCI-DAS1001 features

This manual explains how to install and use the PCI-DAS1001. This board is a multifunction analog and digital I/O board designed for the PCI bus.

The PCI-DAS1001 provides either 16 single-ended or eight differential analog inputs. Input ranges are software-selectable as either bipolar or unipolar.

Analog input ranges for the PCI-DAS1001 board are:

- Bipolar: ± 10 V, ± 1.0 V, ± 0.1 V, ± 0.01 V
- Unipolar: 0 to 10 V, 0 to 1.0 V, 0 to 0.1 V, 0 to 0.01 V

The PCI-DAS1001 provides a 150 kHz sample rate.

The PCI-DAS1001 also provides two channels of 12-bit analog output. Analog output ranges are ± 10 V and ± 5 V (bipolar) and 0-10 V, 0-5 V (unipolar).

The PCI-DAS1001 offers 24-bits of parallel, digital I/O (two 8-bit ports and two 4-bit ports). You can configure each port independently as input or output.

This board has an 82C54 counter chip which has three user-accessible 16-bit counters. Clock, gate, and output signals from two of three counters are available on a 100-pin connector. The third counter is used internally.

The PCI-DAS1001 is fully plug-and-play. All addresses and interrupt channels are set with software.

Software features

For information on the features of *InstaCal* and the other software included with your PCI-DAS1001, refer to the *Quick Start Guide* that shipped with your device. The *Quick Start Guide* is also available in PDF at www.mccdaq.com/PDFmanuals/DAQ-Software-Quick-Start.pdf.

Check www.mccdaq.com/download.htm for the latest software version or versions of the software supported under less commonly used operating systems.

PCI-DAS1001 block diagram

PCI-DAS1001 functions are illustrated in the block diagram shown here.

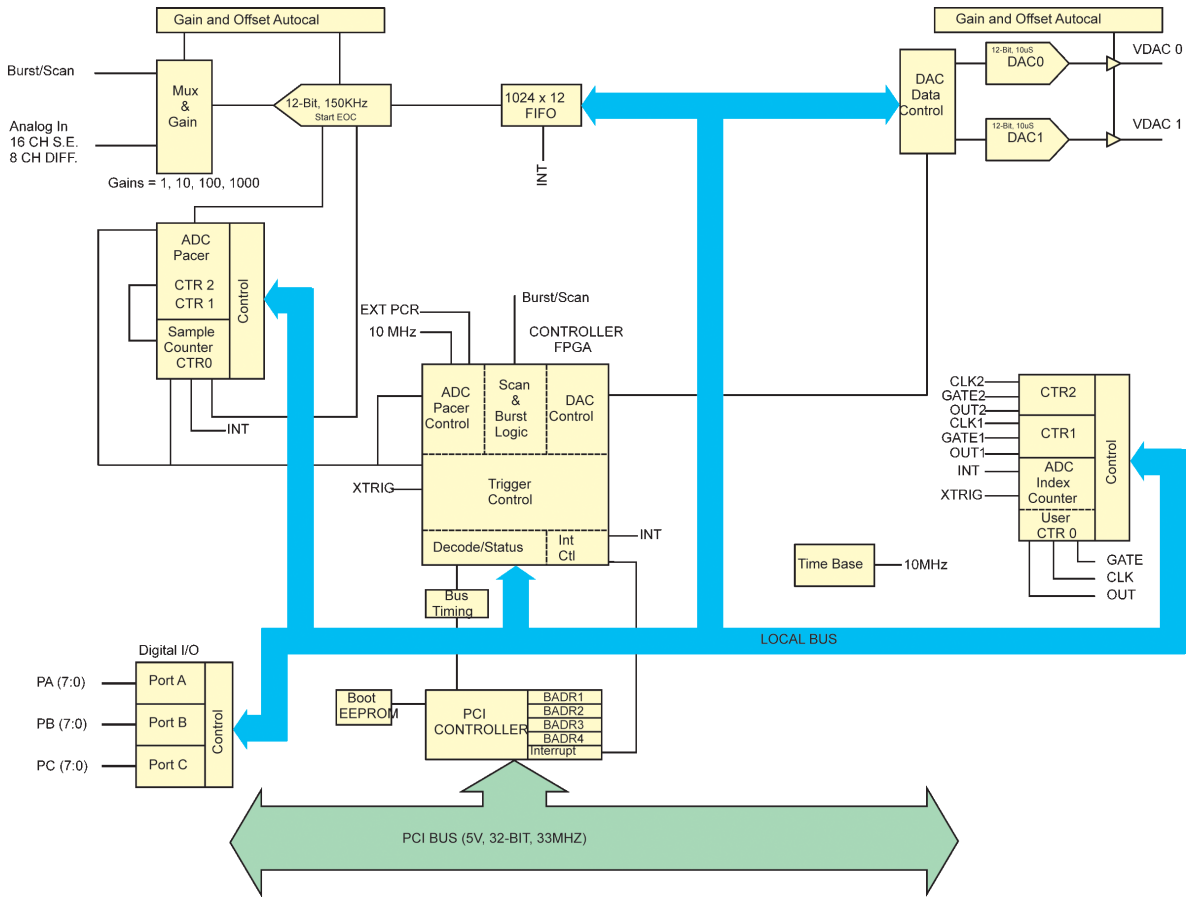

Figure 1. PCI-DAS1001 functional block diagram

Installing the PCI-DAS1001

What is included with your PCI-DAS1001

As you unpack your board, make sure each of the items shown below is included:

Hardware

- PCI-DAS1001

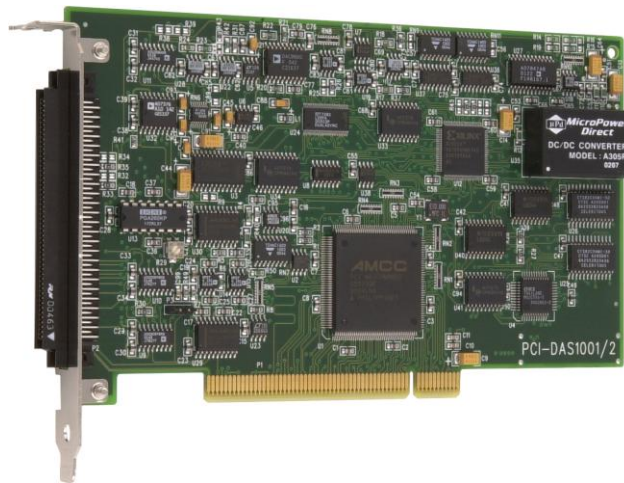

Additional documentation

In addition to this hardware user's guide, you should also receive the *Quick Start Guide* (available in PDF at www.mccdaq.com/PDFmanuals/DAQ-Software-Quick-Start.pdf). This booklet supplies a brief description of the software you received with your PCI-DAS1001 and information regarding installation of that software. Please read this booklet completely before installing any software or hardware.

Optional components

If you ordered any of the following products with your board, they should be included with your shipment.

- C100FF-x cable



- Signal termination and conditioning accessories
MCC provides signal termination and conditioning products for use with the PCI-DAS1001. Refer to the "[Field wiring and signal termination](#)" section for a complete list of compatible accessory products.

Unpacking the PCI-DAS1001

As with any electronic device, you should take care while handling to avoid damage from static electricity. Before removing the PCI-DAS1001 from its packaging, ground yourself using a wrist strap or by simply touching the computer chassis or other grounded object to eliminate any stored static charge.

If any components are missing or damaged, notify Measurement Computing Corporation immediately by phone, fax, or e-mail:

- Phone: 508-946-5100 and follow the instructions for reaching Tech Support.
- Fax: 508-946-9500 to the attention of Tech Support
- Email: techsupport@mccdaq.com

Installing the software

Refer to the *Quick Start Guide* for instructions on installing the software on the *Measurement Computing Data Acquisition Software CD*. This booklet is available in PDF at www.mccdaq.com/PDFmanuals/DAQ-Software-Quick-Start.pdf.

Installing the hardware

The PCI-DAS1001 board is completely plug-and-play. There are no switches or jumpers to set on the board. Configuration is controlled by your system's BIOS. To install your board, follow the steps below.

Install the MCC DAQ software before you install your board

The driver needed to run your board is installed with the MCC DAQ software. Therefore, you need to install the MCC DAQ software before you install your board. Refer to the *Quick Start Guide* for instructions on installing the software.

1. Turn your computer off, open it up, and insert your board into an available PCI slot.
2. Close your computer and turn it on.

If you are using an operating system with support for plug-and-play (such as Windows 2000 or Windows XP), a dialog box pops up as the system loads indicating that new hardware has been detected. If the information file for this board is not already loaded onto your PC, you will be prompted for the disk containing this file. The MCC DAQ software contains this file. If required, insert the *Measurement Computing Data Acquisition Software CD* and click **OK**.

3. To test your installation and configure your board, run the *InstaCal* utility you installed in the previous section. Refer to the *Quick Start Guide* that came with your board www.mccdaq.com/PDFmanuals/DAQ-Software-Quick-Start.pdf for information on how to initially set up and load *InstaCal*.

Allow your computer to warm up for at least 15 minutes before acquiring data with this board. The high speed components used on the board generates heat, and it takes this amount of time for a board to reach steady state if it has been powered off for a significant amount of time.

Configuring the hardware

All hardware configuration options on the PCI-DAS1001 are software controlled. You can select some of the configuration options using *InstaCal*, such as the analog input configuration (16 single-ended or eight differential channels), and the source for the two independent counters. Once selected, any program that uses the Universal Library will initialize the hardware according to these selections.

Following is an overview of the available hardware configuration options for this board. There is additional general information regarding analog signal connection and configuration in the *Guide to Signal Connections* (available on our web site at www.mccdaq.com/signals/signals.pdf).

Differential input mode

When all channels are configured for differential input mode, eight analog input channels are available. In this mode, the input signal is measured with respect to the low input. The input signal is delivered through three wires:

- The wire carrying the signal to be measured connects to CH# IN HI.
- The wire carrying the reference signal connects to CH# IN LO.
- The third wire, typically a system ground, connects to LLGND.

Single-ended input mode

When all channels are configured for single-ended input mode, 16 analog input channels are available. In this mode, the input signal is referenced to the board's signal ground (LLGND). The input signal is delivered through two wires:

- The wire carrying the signal to be measured connects to CH# IN HI.
- The second wire connects to LLGND.

Connecting the board for I/O operations

Connectors, cables – main I/O connector

The table below lists the board connectors, applicable cables, and compatible accessory boards for the PCI-DAS1001.

Board connectors, cables, accessory equipment

Connector type	100-pin high density Robinson Nugent connector
Compatible cable	C100FF-x, unshielded ribbon cable. x = length in feet (Figure 2)
Compatible accessory products (with the C100FF-x cable)	ISO-RACK16/P ISO-DA02/P CIO-ERB08* CIO-ERB24* SSR-RACK08* SSR-RACK24* BNC-16SE BNC-16DI CIO-MINI50 (2 required) CIO-TERM100 (1 required) SCB-50 (1 required)
* These devices require the DADP-5037 PCI-DAS to 37-pin SSR and ERB adapter board.	

Pinout – main I/O connector

8-channel differential mode

Signal Name	Pin		Pin	Signal Name
GND	100	••	50	GND
N/C	99	••	49	N/C
N/C	98	••	48	PC +5V
N/C	97	••	47	N/C
N/C	96	••	46	N/C
A/D Int. Pacer Output	95	••	45	A/D External Trigger
N/C	94	••	44	N/C
N/C	93	••	43	N/C
PC -12V	92	••	42	A/D External Pacer
PC GND	91	••	41	CTR4 OUT
PC +12V	90	••	40	CTR4 GATE
PC GND	89	••	39	CTR4 CLK
N/C	88	••	38	D/A OUT 1
CTR5 OUT	87	••	37	D/A GND 1
CTR5 GATE	86	••	36	D/A OUT 0
CTR5 CLK	85	••	35	D/A GND 0
N/C	84	••	34	N/C
N/C	83	••	33	N/C
CTR6 OUT	82	••	32	N/C
CTR6 GATE	81	••	31	N/C
CTR6 CLK	80	••	30	N/C
N/C	79	••	29	N/C
N/C	78	••	28	N/C
N/C	77	••	27	N/C
N/C	76	••	26	N/C
N/C	75	••	25	N/C
FIRSTPORTC Bit 7	74	••	24	N/C
FIRSTPORTC Bit 6	73	••	23	N/C
FIRSTPORTC Bit 5	72	••	22	N/C
FIRSTPORTC Bit 4	71	••	21	N/C
FIRSTPORTC Bit 3	70	••	20	N/C
FIRSTPORTC Bit 2	69	••	19	N/C
FIRSTPORTC Bit 1	68	••	18	LLGND
FIRSTPORTC Bit 0	67	••	17	CH7 IN LO
FIRSTPORTB Bit 7	66	••	16	CH7 IN HI
FIRSTPORTB Bit 6	65	••	15	CH6 IN LO
FIRSTPORTB Bit 5	64	••	14	CH6 IN HI
FIRSTPORTB Bit 4	63	••	13	CH5 IN LO
FIRSTPORTB Bit 3	62	••	12	CH5 IN HI
FIRSTPORTB Bit 2	61	••	11	CH4 IN LO
FIRSTPORTB Bit 1	60	••	10	CH4 IN HI
FIRSTPORTB Bit 0	59	••	9	CH3 IN LO
FIRSTPORTA Bit 7	58	••	8	CH3 IN HI
FIRSTPORTA Bit 6	57	••	7	CH2 IN LO
FIRSTPORTA Bit 5	56	••	6	CH2 IN HI
FIRSTPORTA Bit 4	55	••	5	CH1 IN LO
FIRSTPORTA Bit 3	54	••	4	CH1 IN HI
FIRSTPORTA Bit 2	53	••	3	CH0 IN LO
FIRSTPORTA Bit 1	52	••	2	CH0 IN HI
FIRSTPORTA Bit 0	51	••	1	LLGND
PCI slot ↓				

16-channel single-ended mode

Signal Name	Pin		Pin	Signal Name
GND	100	••	50	GND
N/C	99	••	49	N/C
N/C	98	••	48	PC +5V
N/C	97	••	47	N/C
N/C	96	••	46	N/C
A/D Int. Pacer Output	95	••	45	A/D External Trigger In
N/C	94	••	44	N/C
N/C	93	••	43	N/C
PC -12V	92	••	42	A/D External Pacer
PC GND	91	••	41	CTR4 OUT
PC +12V	90	••	40	CTR4 GATE
PC GND	89	••	39	CTR4 CLK
N/C	88	••	38	D/A OUT 1
CTR5 OUT	87	••	37	D/A GND 1
CTR5 GATE	86	••	36	D/A OUT 0
CTR5 CLK	85	••	35	D/A GND 0
N/C	84	••	34	N/C
N/C	83	••	33	N/C
CTR6 OUT	82	••	32	N/C
CTR6 GATE	81	••	31	N/C
CTR6 CLK	80	••	30	N/C
N/C	79	••	29	N/C
N/C	78	••	28	N/C
N/C	77	••	27	N/C
N/C	76	••	26	N/C
N/C	75	••	25	N/C
FIRSTPORTC Bit 7	74	••	24	N/C
FIRSTPORTC Bit 6	73	••	23	N/C
FIRSTPORTC Bit 5	72	••	22	N/C
FIRSTPORTC Bit 4	71	••	21	N/C
FIRSTPORTC Bit 3	70	••	20	N/C
FIRSTPORTC Bit 2	69	••	19	N/C
FIRSTPORTC Bit 1	68	••	18	LLGND
FIRSTPORTC Bit 0	67	••	17	CH15 IN
FIRSTPORTB Bit 7	66	••	16	CH7 IN
FIRSTPORTB Bit 6	65	••	15	CH14 IN
FIRSTPORTB Bit 5	64	••	14	CH6 IN
FIRSTPORTB Bit 4	63	••	13	CH13 IN
FIRSTPORTB Bit 3	62	••	12	CH5 IN
FIRSTPORTB Bit 2	61	••	11	CH12 IN
FIRSTPORTB Bit 1	60	••	10	CH4 IN
FIRSTPORTB Bit 0	59	••	9	CH11 IN
FIRSTPORTA Bit 7	58	••	8	CH3 IN
FIRSTPORTA Bit 6	57	••	7	CH10 IN
FIRSTPORTA Bit 5	56	••	6	CH2 IN
FIRSTPORTA Bit 4	55	••	5	CH9 IN
FIRSTPORTA Bit 3	54	••	4	CH1 IN
FIRSTPORTA Bit 2	53	••	3	CH8 IN
FIRSTPORTA Bit 1	52	••	2	CH0 IN
FIRSTPORTA Bit 0	51	••	1	LLGND
PCI slot ↓				

Cables

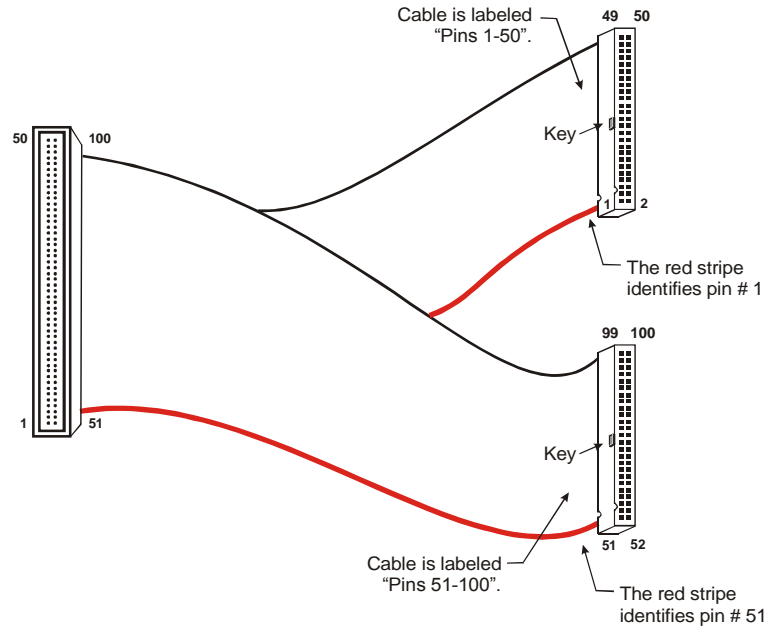

Figure 2. C100FF-x cable

Field wiring and signal termination

The table below lists the MCC screw terminal and signal conditioning boards that are compatible with the PCI-DAS1000.

Screw terminal and BNC adapters	http://www.mccdaq.com/products/accessories.aspx
SCB-50	50-conductor, shielded signal connection box.
CIO-MINI50	50-pin universal screw terminal accessory.
BNC-16SE	16-channel single-ended BNC connector box.
BNC-16DI	Eight-channel differential BNC connector box.
Signal conditioning	http://www.mccdaq.com/products/signal_conditioning.aspx
ISO-RACK16/P	16-channel isolation module mounting rack.
ISO-DA02/P	Two-channel 5B module rack.
SSR-RACK24*	24-position solid state relay rack.
SSR-RACK08*	Eight-channel solid state relay rack.
CIO-ERB24*	24-channel electromechanical relay accessory for digital I/O boards.
CIO-ERB08*	Eight-channel electromechanical relay accessory for digital I/O boards.
* These devices require the DADP-5037 PCI-DAS to 37-pin SSR and ERB adapter board.	

Calibrating the Board

Introduction

Calibrate the board using the *InstaCal* utility after the board has fully warmed up. The recommended warm-up time is 15 minutes. For best results, calibrate the board immediately before making critical measurements. The high resolution analog components on the board are sensitive to temperature. Pre-measurement calibration ensures that your board is operating at optimum calibration values.

Calibration theory

PCI-DAS1001 series boards are shipped fully calibrated from the factory with calibration coefficients stored in nvRAM. When using Universal Library at run time, these calibration factors are loaded into system memory and are automatically retrieved each time a different DAC/ADC range is specified.

The analog input circuits are calibrated for both offset and gain (Figure 3).

- Offset calibration for the analog input is performed directly on the input amplifier (PGIA) with coarse and fine trim DACs acting on the amplifier.
- For input gain calibration, a precision calibration reference is used with coarse and fine trim DACs acting on the ADC.

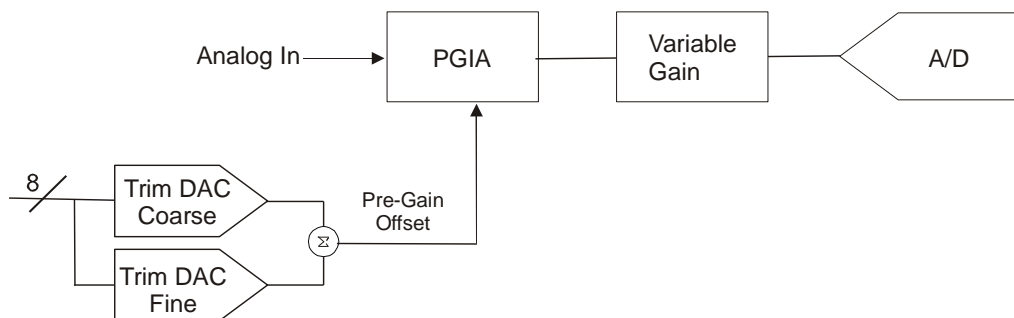

Figure 3. Analog input circuit calibration

The analog outputs are calibrated for both offset and gain (Figure 4). This circuit is duplicated for both DAC0 and DAC1.

- Offset adjustments are made in the output buffer section. The tuning range of this adjustment allows for max DAC and output buffer offsets.
- Gain calibration is performed via DAC reference adjustments.

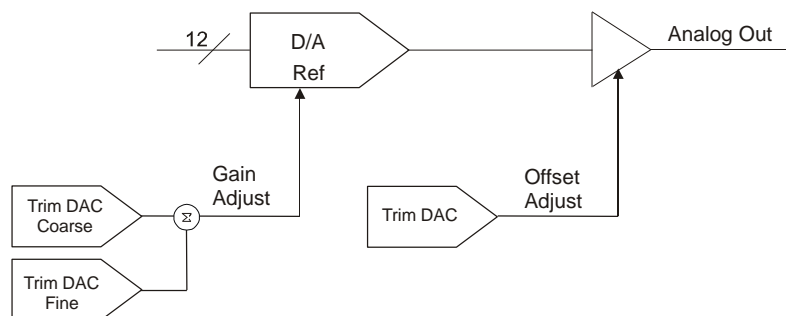

Figure 4. Analog output circuit calibration

Specifications

Typical for 25 °C unless otherwise specified.

Specifications in *italic text* are guaranteed by design.

Analog input

Table 1. Analog input specifications

Parameter	Specification
<i>A/D converter type</i>	7800
Resolution	12 bits
Number of channels	8 differential or 16 single-ended, software selectable
Input ranges	± 10 V, ± 1 V, ± 0.1 V, ± 0.01 V, 0 to 10 V, 0 to 1 V, 0 to 0.1 V, 0 to 0.01 V. Fully programmable
Polarity	Unipolar/bipolar, software selectable
A/D pacing	Programmable: internal counter or external source (A/D External Pacer, positive or negative edge selectable by software), or software polled
Burst mode	Software selectable option, rate = 6.67 μ s
A/D trigger sources	External digital (A/D External Trigger)
A/D triggering modes	Digital: Software enabled, rising edge, hardware trigger Pre-trigger: Unlimited pre- and post-trigger samples. Total # of samples must be > 512.
Data transfer	From 1024 sample FIFO via REPINSW, interrupt or software polled
<i>A/D conversion time</i>	3 μ s
Throughput	150 kHz
Relative accuracy	± 1.5 LSB
Differential linearity error	± 0.75 LSB
Integral linearity error	± 0.5 LSB typ, ± 1.5 LSB max
Gain error (relative to calibration reference)	0.01 V range: $\pm 0.4\%$ of reading, max All other ranges: $\pm 0.02\%$ of reading, max
<i>No missing codes guaranteed</i>	12 bits
Calibration	Auto-calibration, calibration factors for each range stored on board in non-volatile RAM
<i>Gain drift (A/D specs)</i>	± 6 ppm/°C
<i>Zero drift (A/D specs)</i>	± 1 ppm/°C
Common mode range	± 10 V
CMRR @ 60 Hz	70 dB
<i>Input leakage current</i>	200 nA
<i>Input impedance</i>	10 MOhms, min
<i>Absolute maximum input voltage</i>	± 35 V
Noise distribution	Rate = 1-150 kHz, average # bins 10 V ranges: 3 bins 1 V ranges: 4 bins 0.1 V ranges: 10 bins Bipolar 0.01 V range: 20 bins Unipolar 0.01 V range: 32 bins

Analog output

Table 2. Analog output specifications

Parameter	Specification
<i>D/A type</i>	AD7847AR
<i>Resolution</i>	12 bits
<i>Number of channels</i>	2
<i>Output ranges</i>	± 10 V, ± 5 V, 0 to 5 V, 0 to 10 V. Each channel independently programmable.
<i>D/A pacing</i>	Software
<i>Data transfer</i>	Programmed I/O
<i>Offset error</i>	± 600 μ V max, all ranges (calibrated)
<i>Gain error</i>	$\pm 0.02\%$ FSR max (calibrated)
<i>Differential nonlinearity</i>	± 1 LSB max
<i>Integral nonlinearity</i>	± 1 LSB max
<i>Monotonicity</i>	12 bits
<i>D/A gain drift</i>	± 2 ppm/ $^{\circ}$ C max
<i>D/A bipolar offset drift</i>	± 5 ppm/ $^{\circ}$ C max
<i>D/A unipolar offset drift</i>	± 5 ppm/ $^{\circ}$ C max
<i>Throughput</i>	PC dependent
<i>Settling time (to 0.01% of 10 V step)</i>	4 μ s typ
<i>Slew rate</i>	7 V/ μ S
<i>Current drive</i>	± 5 mA min
<i>Output short-circuit duration</i>	25 mA indefinite
<i>Output coupling</i>	DC
<i>Amp output impedance</i>	0.1 Ohms max
<i>Miscellaneous</i>	Power up and reset, all DACs cleared to 0 V, ± 200 mV

Digital input/output

Table 3. DIO specifications

Parameter	Specification
<i>Digital type</i>	82C55A
<i>Configuration</i>	2 banks of 8, 2 banks of 4, programmable by bank as input or output
<i>Number of channels</i>	24 I/O (FIRSTPORTA 0 through FIRSTPORTC 7)
<i>Output high</i>	3.0 V, min @ -2.5 mA
<i>Output low</i>	0.4 V, max @ 2.5 mA
<i>Input high</i>	2.0 V, min, +5.5 V absolute, max
<i>Input low</i>	0.8 V, max, -0.5 V absolute, min
<i>Power-up / reset state</i>	Input mode (high impedance)
<i>Interrupts</i>	INTA# - mapped to IRQn via PCI BIOS at boot-time
<i>Interrupt enable</i>	Programmable
<i>Interrupt sources</i>	Residual counter, end-of-channel-scan, AD-FIFO-not-empty, AD-FIFO-half-full

Counter section

Table 4. Counter specifications

Parameter		Specification
<i>Counter type</i>		82C54
<i>Configuration</i>		Two 82C54 devices. 3 down counters per 82C54, 16 bits each
82C54A:	Counter 0 - ADC residual sample counter	<ul style="list-style-type: none"> ▪ Source: ADC Clock. ▪ Gate: Internal programmable source. ▪ Output: End-of-Acquisition interrupt.
	Counter 1 - ADC pacer lower divider	<ul style="list-style-type: none"> ▪ Source: 10 MHz oscillator ▪ Gate: tied to counter 2 gate, programmable source. ▪ Output: chained to counter 2 clock.
	Counter 2 - ADC pacer upper divider	<ul style="list-style-type: none"> ▪ Source: counter 1 output. ▪ Gate: Tied to counter 1 gate, programmable source. ▪ Output: ADC pacer clock (if software selected), available at user connector.
82C54B:	Counter 0 - pretrigger mode	<ul style="list-style-type: none"> ▪ Source: ADC clock ▪ Gate: external trigger ▪ Output: End-of-Acquisition interrupt
	Counter 0 - user counter 4 (when in non-pretrigger mode)	<ul style="list-style-type: none"> ▪ Source: User input at 100-pin connector (CLK4) or internal 10 MHz (software selectable) ▪ Gate: user input at 100-pin connector (GATE4) ▪ Output: available at 100-pin connector (OUT4)
	Counter 1 - user counter 5	<ul style="list-style-type: none"> ▪ Source: user input at 100-pin connector (CLK5) ▪ Gate: user input at 100-pin connector (GATE5) ▪ Output: available at 100-pin connector (OUT5)
	Counter 2 - user counter 6	<ul style="list-style-type: none"> ▪ Source: user input at 100-pin connector (CLK6) ▪ Gate: user input at 100-pin connector (GATE6) ▪ Output: available at 100-pin connector (OUT6)
<i>Clock input frequency</i>		10 MHz max
<i>High pulse width (clock input)</i>		30 ns min
<i>Low pulse width (clock input)</i>		50 ns min
<i>Gate width high</i>		50 ns min
<i>Gate width low</i>		50 ns min
<i>Input low voltage</i>		0.8 V max
<i>Input high voltage</i>		2.0 V min
<i>Output low voltage</i>		0.4 V max
<i>Output high voltage</i>		3.0 V min

Power consumption

Table 5. Power consumption specifications

Parameter	Specification
+5 V operating (A/D converting to FIFO)	0.8 A typical, 1.0 A max

Environmental

Table 6. Environmental specifications

Parameter	Specification
<i>Operating temperature range</i>	<i>0 to 70 °C</i>
<i>Storage temperature range</i>	<i>-40 to 100 °C</i>
<i>Humidity</i>	<i>0 to 90% non-condensing</i>

Main connector and pin out

Connector type	100-pin high density Robinson Nugent	
Compatible cable	C100FF-x, unshielded ribbon cable. x = length in feet	
Compatible accessory products (with C100FF-x cable)	ISO-RACK16/P ISO-DA02/P CIO-ERB24 (DADP-5037 adaptor required) CIO-SERB24 (DADP-5037 adaptor required) SSR-RACK24 (DADP-5037 adaptor required)	BNC-16SE BNC-16DI CIO-MINI50 (2 required) CIO-TERM100 (1 required) SCB-50 (1 required)

8-channel differential mode pin out

Pin	Signal Name	Pin	Signal Name
1	LLGND	51	FIRSTPORTA Bit 0
2	CH0 IN HI	52	FIRSTPORTA Bit 1
3	CH0 IN LO	53	FIRSTPORTA Bit 2
4	CH1 IN HI	54	FIRSTPORTA Bit 3
5	CH1 IN LO	55	FIRSTPORTA Bit 4
6	CH2 IN HI	56	FIRSTPORTA Bit 5
7	CH2 IN LO	57	FIRSTPORTA Bit 6
8	CH3 IN HI	58	FIRSTPORTA Bit 7
9	CH3 IN LO	59	FIRSTPORTB Bit 0
10	CH4 IN HI	60	FIRSTPORTB Bit 1
11	CH4 IN LO	61	FIRSTPORTB Bit 2
12	CH5 IN HI	62	FIRSTPORTB Bit 3
13	CH5 IN LO	63	FIRSTPORTB Bit 4
14	CH6 IN HI	64	FIRSTPORTB Bit 5
15	CH6 IN LO	65	FIRSTPORTB Bit 6
16	CH7 IN HI	66	FIRSTPORTB Bit 7
17	CH7 IN LO	67	FIRSTPORTC Bit 0
18	LLGND	68	FIRSTPORTC Bit 1
19	N/C	69	FIRSTPORTC Bit 2
20	N/C	70	FIRSTPORTC Bit 3
21	N/C	71	FIRSTPORTC Bit 4
22	N/C	72	FIRSTPORTC Bit 5
23	N/C	73	FIRSTPORTC Bit 6
24	N/C	74	FIRSTPORTC Bit 7
25	N/C	75	N/C
26	N/C	76	N/C
27	N/C	77	N/C
28	N/C	78	N/C
29	N/C	79	N/C
30	N/C	80	CTR6 CLK
31	N/C	81	CTR6 GATE
32	N/C	82	CTR6 OUT
33	N/C	83	N/C
34	N/C	84	N/C
35	D/A GND 0	85	CTR5 CLK
36	D/A OUT 0	86	CTR5 GATE
37	D/A GND 1	87	CTR5 OUT
38	D/A OUT 1	88	N/C
39	CTR4 CLK	89	GND
40	CTR4 GATE	90	+12V
41	CTR4 OUT	91	GND
42	A/D EXTERNAL PACER	92	-12V
43	N/C	93	N/C
44	N/C	94	N/C
45	A/D EXTERNAL TRIGGER IN	95	A/D INTERNAL PACER OUTPUT
46	N/C	96	N/C
47	N/C	97	N/C
48	PC +5V	98	N/C
49	N/C	99	N/C
50	GND	100	GND

16-channel single-ended mode pin out

Pin	Signal Name	Pin	Signal Name
1	LLGND	51	FIRSTPORTA Bit 0
2	CH0 IN	52	FIRSTPORTA Bit 1
3	CH8 IN	53	FIRSTPORTA Bit 2
4	CH1 IN	54	FIRSTPORTA Bit 3
5	CH9 IN	55	FIRSTPORTA Bit 4
6	CH2 IN	56	FIRSTPORTA Bit 5
7	CH10 IN	57	FIRSTPORTA Bit 6
8	CH3 IN	58	FIRSTPORTA Bit 7
9	CH11 IN	59	FIRSTPORTB Bit 0
10	CH4 IN	60	FIRSTPORTB Bit 1
11	CH12 IN	61	FIRSTPORTB Bit 2
12	CH5 IN	62	FIRSTPORTB Bit 3
13	CH13 IN	63	FIRSTPORTB Bit 4
14	CH6 IN	64	FIRSTPORTB Bit 5
15	CH14 IN	65	FIRSTPORTB Bit 6
16	CH7 IN	66	FIRSTPORTB Bit 7
17	CH15 IN	67	FIRSTPORTC Bit 0
18	LLGND	68	FIRSTPORTC Bit 1
19	N/C	69	FIRSTPORTC Bit 2
20	N/C	70	FIRSTPORTC Bit 3
21	N/C	71	FIRSTPORTC Bit 4
22	N/C	72	FIRSTPORTC Bit 5
23	N/C	73	FIRSTPORTC Bit 6
24	N/C	74	FIRSTPORTC Bit 7
25	N/C	75	N/C
26	N/C	76	N/C
27	N/C	77	N/C
28	N/C	78	N/C
29	N/C	79	N/C
30	N/C	80	CTR6 CLK
31	N/C	81	CTR6 GATE
32	N/C	82	CTR6 OUT
33	N/C	83	N/C
34	N/C	84	N/C
35	D/A GND 0	85	CTR5 CLK
36	D/A OUT 0	86	CTR5 GATE
37	D/A GND 1	87	CTR5 OUT
38	D/A OUT 1	88	N/C
39	CTR4 CLK	89	GND
40	CTR4 GATE	90	+12V
41	CTR4 OUT	91	GND
42	A/D EXTERNAL PACER	92	-12V
43	N/C	93	N/C
44	N/C	94	N/C
45	A/D EXTERNAL TRIGGER IN	95	A/D INTERNAL PACER OUTPUT
46	N/C	96	N/C
47	N/C	97	N/C
48	PC +5V	98	N/C
49	N/C	99	N/C
50	GND	100	GND

CE Declaration of Conformity

Manufacturer: Measurement Computing Corporation
Address: 10 Commerce Way
Suite 1008
Norton, MA 02766
USA

Category: Information technology equipment.

Measurement Computing Corporation declares under sole responsibility that the product

PCI-DAS1001

to which this declaration relates is in conformity with the relevant provisions of the following standards or other documents:

EC EMC Directive 2004/108/EC: Electromagnetic Compatibility, EN 61326-1:2006 (IEC 61326-1:2005)

Emissions: Group 1, Class B

- EN55022 (1995)/CISPR 22: Radiated and Conducted emissions.

Immunity: EN61326-1:2006, (IEC 61326-1:2005)

- EN61000-4-2 (2001): Electrostatic Discharge immunity.
- EN61000-4-3 (2002): Radiated Electromagnetic Field immunity.
- EN61000-4-4 (2004): Electric Fast Transient Burst immunity.
- EN61000-4-5 (2001): Surge immunity.
- EN61000-4-6 (2003): Radio Frequency Common Mode immunity.
- EN61000-4-11 (2004): Voltage Dip and Interrupt immunity.

Declaration of Conformity based on tests conducted by Chomerics Test Services, Woburn, MA 01801, USA in September, 2001. Test records are outlined in Chomerics Test Report #EMI3053.01. Further testing was conducted by Chomerics Test Services, Woburn, MA. 01801, USA in December, 2008. Test records are outlined in Chomerics Test report #EMI5241.08.

We hereby declare that the equipment specified conforms to the above Directives and Standards.



Carl Haapaoja, Director of Quality Assurance

Measurement Computing Corporation
10 Commerce Way
Suite 1008
Norton, Massachusetts 02766
(508) 946-5100
Fax: (508) 946-9500
E-mail: info@mccdag.com
www.mccdag.com