

# OWNER'S MANUAL

# PEDESTAL PLATE HEATER



**MODEL**  
**2007**



EXEMPT PER  
EPA METHOD 28A

TESTED TO  
UL 1482  
&  
CAN/ULC - S627

### **CAUTION!**

**Read All Instructions Carefully  
Before Starting The Installation  
or Operating This Heater.**

**Improper Installation Could Void  
Your Warranty!**

### **SAFETY NOTICE:**

**If this heater is not properly installed, a house fire may result. For your safety, follow the installation instructions. Contract local building or fire officials about restrictions and installation requirements in your area.**

**DO NOT USE THIS HEATER  
IN A MOBILE HOME OR TRAILER**

### **SAVE THIS MANUAL FOR FUTURE REFERENCE**

**THIS MANUAL WILL HELP YOU TO OBTAIN EFFICIENT, DEPENDABLE SERVICE FROM THE HEATER, AND ENABLE YOU TO ORDER REPAIR PARTS CORRECTLY. KEEP IN A SAFE PLACE FOR FUTURE REFERENCE.**

**Distributed By:**  
**UNITED STATES STOVE COMPANY**  
227 INDUSTRIAL PARK ROAD  
P.O. BOX 151  
SOUTH PITTSBURG, TN 37380

# CONGRATULATIONS!

You've purchased a heater from North America's oldest manufacturer of wood burning products.

By heating with wood you're helping to CONSERVE ENERGY!

Wood is our only Renewable Energy Resource. Please do your part to preserve our wood supply. Plant at least one tree each year. Future generations will thank you.

---

## tools and materials needed

### TOOLS

Pencil  
6 Foot Folding Rule or Tape Measure  
Drill, Hand or Electric  
Drill Bit 1/8" Dia. (For Sheet Metal Screws)  
5/16" Nut Driver or  
5/16" Socket w/Ratchet  
Screw Driver (Blade-Type)  
Gloves  
Safety Glasses

### MATERIALS

6" Pipe, 6" Elbow, Collar and Thimble; As Required  
(24 gauge min.)  
1/2" Sheet Metal Screws (No. 10A x 1/2")  
6" Inside Diameter Underwriters Laboratories (UL)  
Listed Residential Solid Fuel Factory-Built  
Triplewall Chimney or Exiting Masonry Chimney.  
In Canada, chimney must comply with CAN/ULC S629  
Floor Protector Material As Specified in  
Figures 2,3, &4.  
Furnace Cement (Manufacturer Recommends:  
Rutland Black Code 78 or Equivalent)

## Dimensions

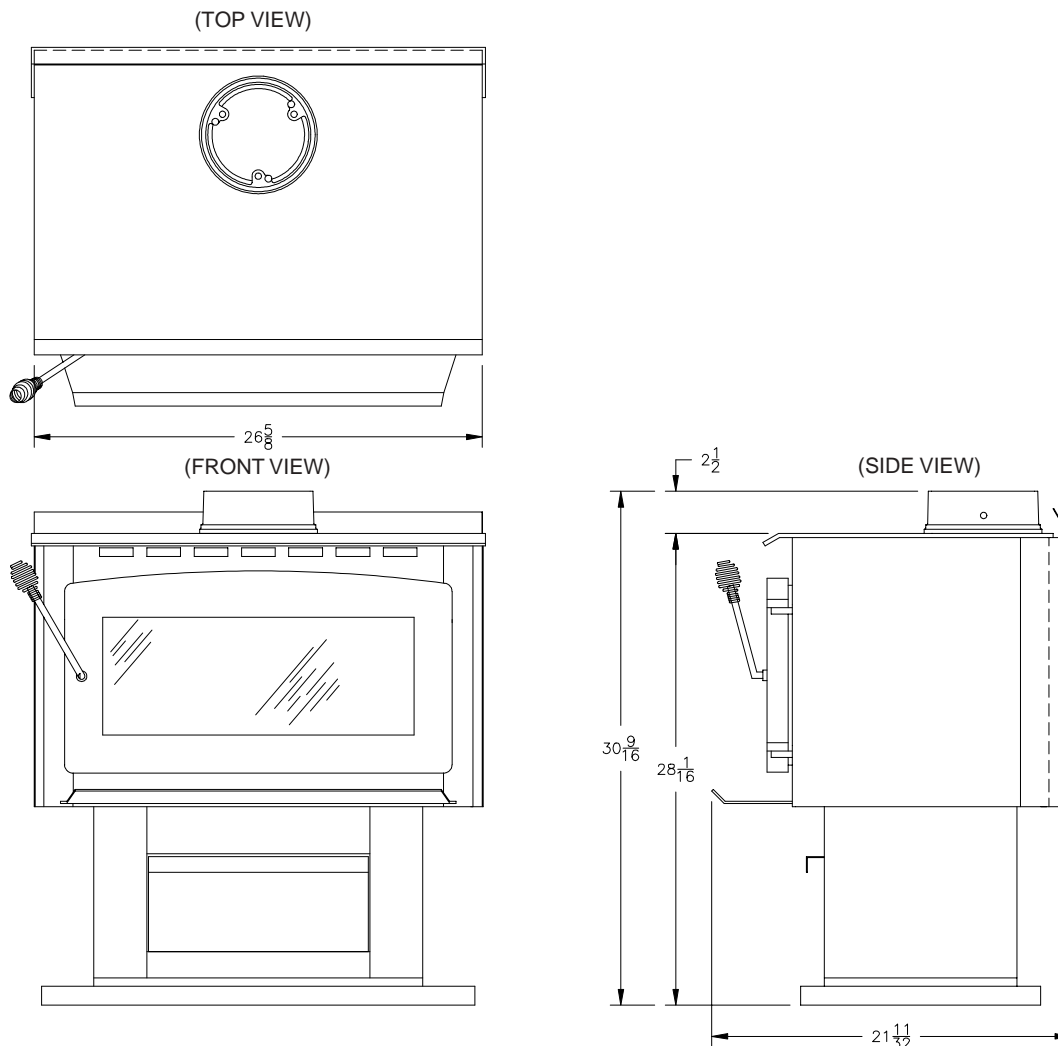

# SAFETY RULES

**SAFETY NOTICE:** If this heater is not properly installed a house fire may result. For your safety, follow the installation directions. Contact local building or fire officials about restrictions and installation inspection requirements in your area.

Read these rules and the instructions carefully.

1. Check with local codes. The installation comply with their rulings. Observe closely the clearances to combustibles (page 4).
2. Do not install this heater in a mobile home or trailer.  
DO NOT connect a wood burning heater to an aluminum Type B gas vent. This is not safe and is prohibited by the National Fire Protection Association Code and Canadian Standards.
3. Always connect this heater to a chimney and vent to the outside. Never vent to another room or inside a building.
4. The freestanding room heater requires a masonry or a UL/ULC Listed Residential Type and Building Heating Appliance Chimney.
5. Be sure that your chimney is safely constructed and in good repair. Have the chimney inspected by the Fire Department or a qualified inspector. Your insurance company may be able to recommend a qualified inspector.
6. Make sure the chimney is high enough to give a good draft.
7. Inspect chimney connector and chimney twice monthly during the heating season for any deposit of creosote or soot which must be removed (see Chimney Maintenance, page 10).
8. DO NOT BE ALARMED IF HEATER SMOKES UPON INITIAL FIRING. The special paint used on this heater must be cured during initial firing. This smoking will occur only on initial firing.
9. CAST IRON PARTS MUST BE "SEASONED" TO AVOID CRACKING. BUILD ONLY SMALL FIRES DURING THE FIRST FEW DAYS OF USE.  
  
To prevent injury, do not allow anyone to use this heater who is unfamiliar with the correct operation of the heater.  
  
For additional information on using your Room Heater safely, obtain a copy of the National Fire Protection Association (NFPA) publication "Chimneys, Fireplaces, and Solid Fuel Burning Appliances" NFPA No. 211(USA). In Canada, obtain a copy of CAN/CSA-B365-M91 National Standard for solid fuel burning appliances and equipment installation.
- 10.
- 11.
12. Disposal of Ashes- Place ashes in a metal container with a tight fitting lid. Keep the closed container on a non-combustible floor or on the ground, well away from all combustible materials. Keep the ashes in the closed container until all cinders have thoroughly cooled. The ashes may be buried in the ground or picked up by a refuse collector.
13. Keep the firebox section free of excess ashes.
14. Observe clearances to combustible materials specified in this manual to avoid a fire hazard.
15. CARING FOR PAINTED PARTS- This heater has a painted jacket, which is durable but it will not stand rough handling or abuse. When installing your heater, use care in handling. Clean with soap and warm water when heater is not hot. DO NOT use any acids or scouring soap, as these wear and dull the finish. PAINT DISCOLORATION WILL OCCUR IF THE HEATER IS OVERFIRED. FOLLOW OPERATING INSTRUCTIONS CAREFULLY.
16. The firebox walls in this heater may become slightly distorted over a period of use. The slight distortion does not affect the operation of the unit.
17. CAUTION: HOT WHILE IN OPERATION. KEEP CHILDREN, CLOTHING, AND FURNITURE AWAY. CONTACT MAY CAUSE SKIN BURNS.
18. CAUTION: DO NOT CONNECT TO ANY AIR DISTRIBUTION OR DUCT SYSTEM.
19. CAUTION: STORE SOLID WOOD FUEL A SAFE DISTANCE AWAY. DO NOT STORE SOLID WOOD FUEL WITHIN HEATER INSTALLATION CLEARANCES OR WITHIN THE SPACE REQUIRED FOR ASH REMOVAL.
20. DO NOT USE A GRATE OR ELEVATE THE FIRE.
21. WE RECOMMEND THAT SMOKE DETECTORS BE INSTALLED IN YOUR HOME.

**CAUTION! Do not touch the metal or glass surfaces of the heater until it has thoroughly cooled.**

# LOCATING THE ROOM HEATER

## AS A LOCATION IS SELECTED, KEEP THE FOLLOWING IN MIND:

1. Keep the chimney connection as short as possible. The heater must have its own chimney flue. Do not connect any other appliance to the same flue. If there is no chimney where you wish to place the heater, you can use a UL Listed Type 103 HT, Solid Fuel, Factory Built Chimney. (Figure 7)
2. Place the heater on solid masonry or solid concrete. When the heater is used on a combustible floor, use a non-combustible floor protector having a thermal conductivity of  $K=0.45 \text{ BTU in./ft. 2 hr.deg. F.}$  with 28 gauge sheet metal or a UL Listed Floor Protector.
3. Have the floor protector with the specified dimensions. (See Figure 2.)
3. Check Figures 2, 3, & 4. You should have at least the clearances shown from the heater and the connector pipe to combustible surfaces. If you have a solid brick or stone wall behind your heater, you can place the heater as close as you wish to the wall. If the wall is only faced with brick or stone, treat it as a combustible wall.

## MINIMUM CLEARANCE TO COMBUSTIBLE WALLS

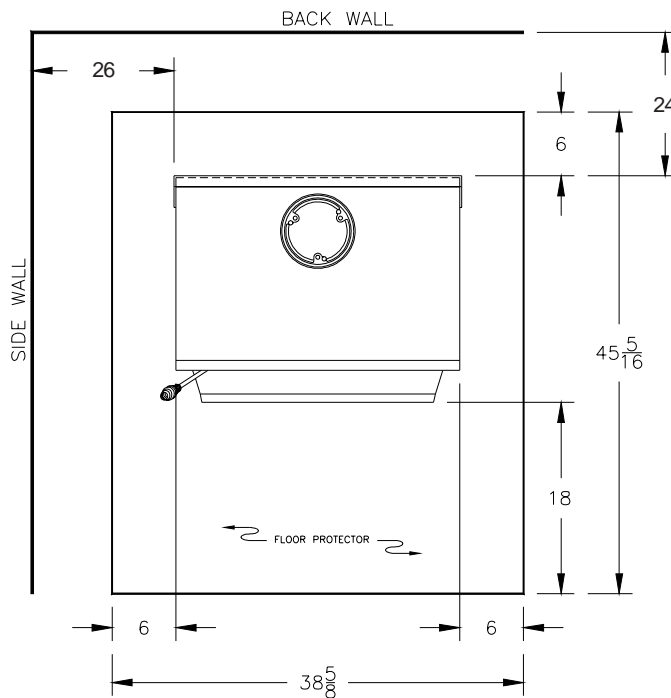

MINIMUM CLEARANCES FOR **CORNER INSTALLATION IS 18 INCHES** FROM THE CORNERS OF THE HEATER TO THE NEAREST WALL

CAUTION  
KEEP FURNISHINGS  
AND OTHER COM-  
BUSTIBLE MATERIALS  
AWAY FROM THE  
HEATER

TOP VIEW  
Fig. 2

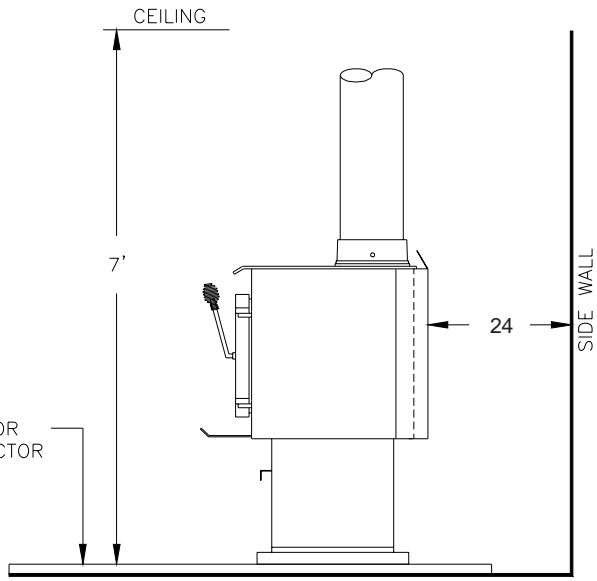
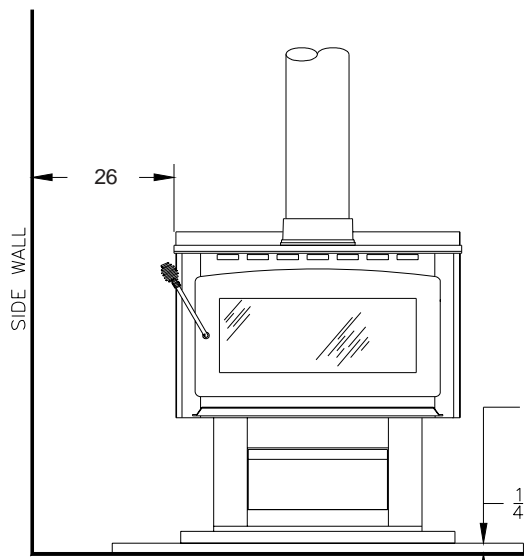

FRONT VIEW  
Fig. 3

SIDE VIEW  
Fig. 4

# MOUNTING CAST-IRON FLUE COLLAR

This heater comes equipped with a cast-iron flue collar with holes to mount the solid damper as shown below.

Flue Collar - 2708

Solid Damper - 2709

5/16-18 x 1-1/2" Bolts (3 req.)

Weld Tab (3 req.)

Gasket

Holes in Flue collar where bolts attach to heater top.

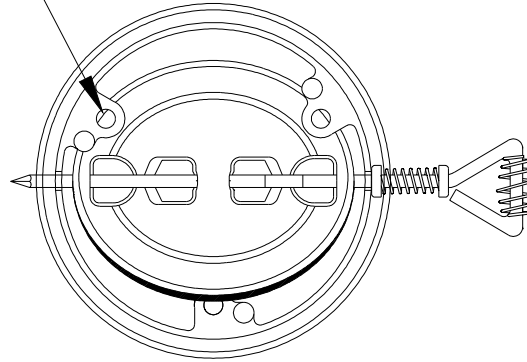

**Bottom view of flue collar with damper installed**

Peel off tape from the back of the gasket and attach the gasket to the rope groove in the flue collar.

Mount flue collar to the top of the heater using the (3) 5/16-18 x 1-1/2" Bolts and the (3) Weld tabs provided in the parts bag.

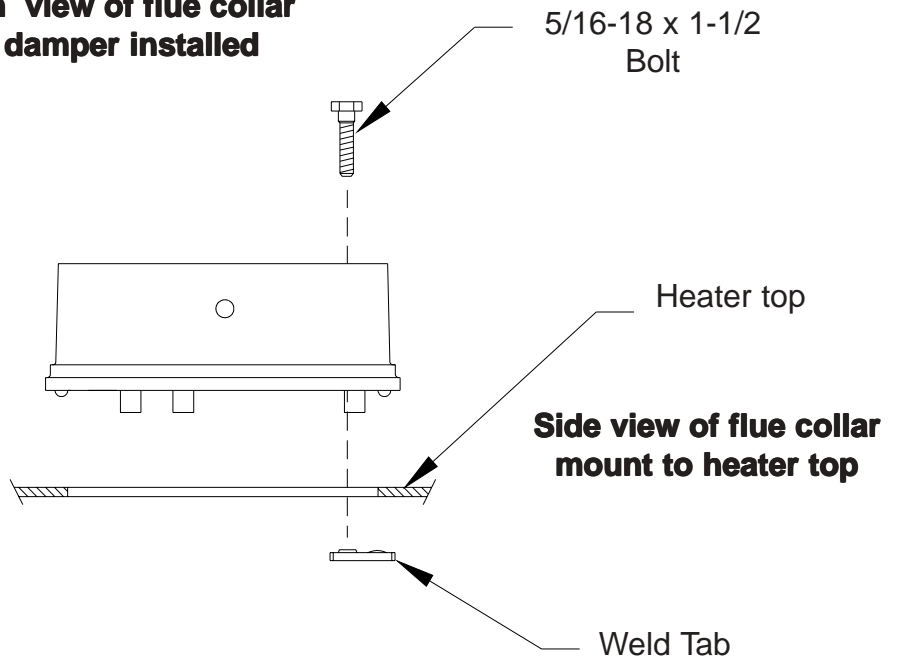

The damper must be install as shown in this illustration. Slide the damper into the flue collar on an angle and then slide the damper handle thru the holes in the flue collar.

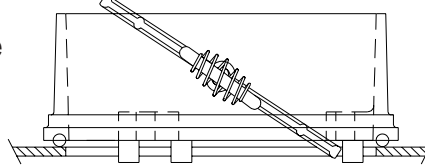

**Cross-section of flue collar**

# CHIMNEY CONNECTION

Two basic types of chimneys are approved for use with solid fuel. Factory-built and masonry. Factory-built chimney must comply with UL/ULC standard in the US and Canada.

Do not expect your stove or furnace to create draft. Draft is not a function of the appliance. Draft is purely a function of the chimney. Modern stoves and furnaces are much more airtight and efficient than those of the past, and, therefore, require greater draft. A minimum of .05" measured in water column (gauges to measure chimney draft are readily available at stove shops and are economical to purchase or rent) is required for proper drafting to prevent back-puffing, smoke spillage, and to maximize performance.

Chimneys perform two functions - one of which is apparent: The chimney provides a means for exhausting smoke and flue gases resulting from combustion of the fuel. Secondly, though, the chimney provides "Draft" which allows oxygen to be continuously introduced into the appliance, so that proper combustion is possible. As of April 1, 1987, all wood heaters and furnaces manufactured by United States Stove Company should be installed using a factory-built chimney that meets the "Type HT" requirement of UL 103 (when a factory-built chimney is used).

A chimney connector shall not pass through an attic, roof space, closet, floor, ceiling, or similar concealed space. Where passage through a wall or partition of combustible construction is desired, the installation must conform with NFPA 211 or CAN/CSA-B365.

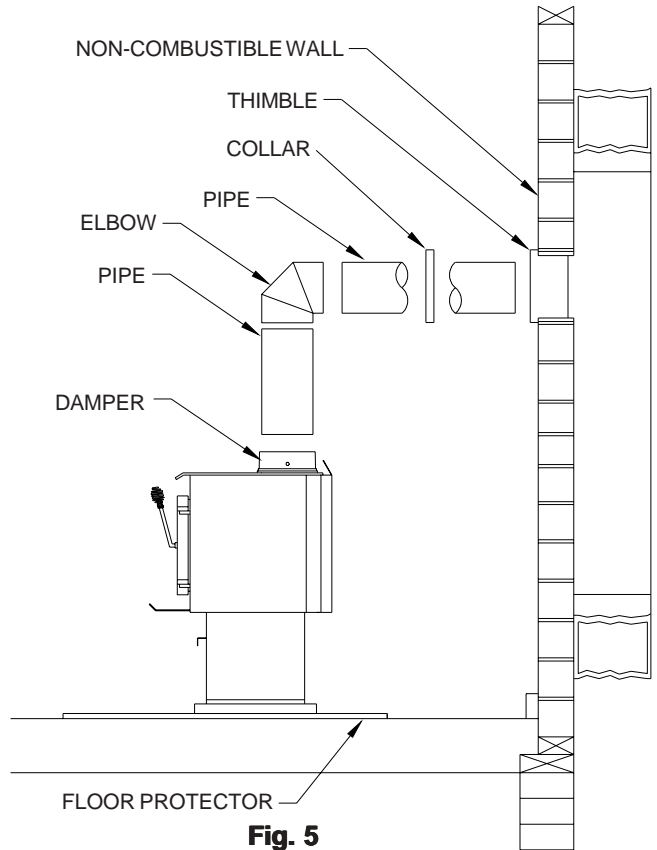

**Fig. 5**

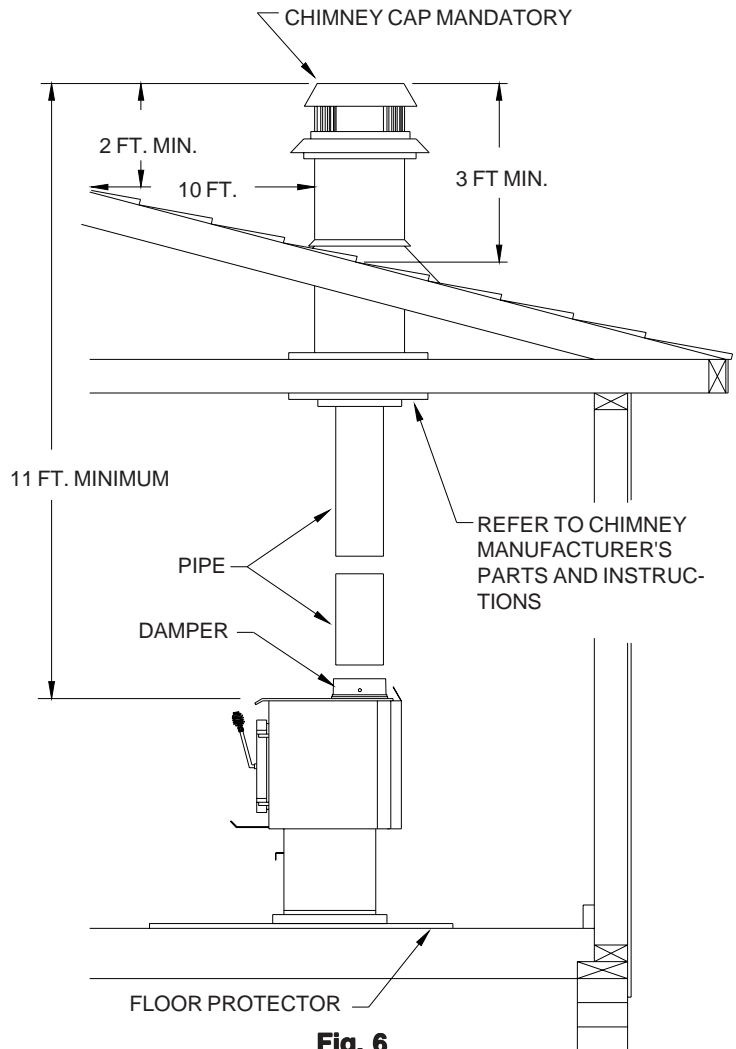

**Fig. 6**

## VENTING INTO A FIREPLACE

Many people may wish to convert an existing fireplace to heater use. Usually, safe connection of stovepipe to a masonry chimney requires more effort than connection to a prefabricated chimney. The fireplace must be tightly closed and sealed at the damper in the flue. Good sealants are high-temperature caulking, ceramic wool, and furnace cement. Always remember to inspect the masonry chimney and fireplace. If necessary, clean the flue and smoke shelf before beginning your installation. Install the heater into the fireplace so that the system can be dismantled for cleaning and inspection.

Before deciding to convert your fireplace, keep in mind that some fireplaces and existing chimneys are unsafe. They must be structurally sound, and the flue liner must be in good condition. Do not use a chimney if it is unlined (should have a fire clay tile liner to protect brickwork). Have it relined professionally. Clearances to combustibles are explained in the previous section on masonry chimneys. If you have any questions regarding the condition of the chimney, consult a qualified engineer, competent mason, or knowledgeable inspector.

Many prefabricated fireplaces fall into the "zero-clearance fireplace" category. This is a factory-built metal fireplace with multilayered construction. It is designed to provide enough insulation and/or air cooling so that the base, back and sides can be safely placed in direct contact with combustible floors and walls. Although many prefabricated fireplaces have been tested by nationally recognized organizations for use as fireplaces, they have not been tested to accept heaters. In fact, their use as such may void the manufacturer's warranty.

Steel-lined fireplaces, on the other hand, can be used with heaters. These units use a 1/4-inch firebox liner and an air chamber in connection with 8 inches of masonry to meet code. They contain all the essential parts of a fireplace, firebox, damper, throat, smoke shelf, and smoke chamber. Many of them look exactly like a masonry fireplace and must be checked closely for above requirements before installing a wood heater into them.

Another method frequently used by some people is to vent the heater directly into the fireplace. This does not meet code since the heater is being vented into another appliance - the fireplace. This method should not be attempted because combustion products will deposit and build up in the firebox or fireplace. Be certain not to install a hazard in your house. You will void your warranty with this installation.

**CAUTION:  
NOT ALL FIREPLACES ARE  
SUITABLE FOR INSTALLATION  
OF A WOOD HEATER.**

When considering a masonry chimney, round tiles are preferable to square or rectangular, as round tiles have much better airflow characteristics and are far easier to clean. Unfortunately, most North American chimneys use square or rectangular tile liners that are really designed for open fireplaces, not stoves or furnaces. Of most importance, second only to overall chimney height, is the diameter of the flue liner itself. In most instances, it should be sized to the appliance; i.e., 6" flue outlet on the appliance requires a 6" chimney. The inner diameter should never be less than the flue-outlet diameter and should never be greater than 50% larger than the appliance flue outlet. For example, do not expect a wood or coal burning stove or furnace to function properly if installed into a chimney with a flue greater than 50% more than the appliance outlet - - such as a 6" flue outlet requires a 6" diameter for optimum drafting, but can function well with an 8", but becomes borderline beyond an 8" diameter.

Masonry chimneys built of concrete blocks with or without flue liners do not meet modern building codes. A solid fuel appliance must not be joined to a chimney flue which is connected to another appliance burning other fuels.

If your chimney has a typically oversized flue liner of, say 8 x 12 inches, or greater, or if it is unlined, it will be necessary for you to reline the chimney, using any of the modern approved and economical methods such as stainless steel, castable refractory, or properly sized fireclay linings.

If you have any questions regarding venting your appliance, feel free to contact the factory at the address and phone number on this Owner's Manual. You may also contact NFPA (National Fire Protection Association) and request NFPA Standard 211 (1984 Edition-US) or Canadian Standard Association and request CAN/CSA-B365-M91(Canada). Another helpful publication is NFPA Standard 908(US). Specify 1984 Edition of either of the above US publications.



# "FIREPLACE" INSTALLATION (CONT'D)

## FIREPLACE INSTALLATION

Connection of the stovepipe directly into the existing masonry chimney over the fireplace opening is a more desirable method. This installation performs better, yielding more heat and better draft; it is also easy to clean and inspect for creosote. Before beginning this type of installation plan carefully; a high degree of skill is required to insure safety.

An entry port for the stovepipe must be cut through the chimney with minimum damage to the fireclay liner. Some involved measurements may be required to locate the flue liner exactly. Before cutting, take time to mark the size and position of the entry port. Position the entry port so that at least 8 inches of the flue liner remains below the port.

Keep in mind that wood mantels and combustible trim around the fireplace must have adequate clearances from the heater and stovepipe or must be protected in an approved manner. Also, be sure to leave at least an 18 inch clearance between the top of the stovepipe and the combustible ceiling or other combustibles. Placing the center of the entry port 2 feet below the ceiling will insure proper clearance for 6-inch, 8-inch, and 10-inch stovepipes. Next, install a fireclay (at least 5/8 inch thick) or metal thimble, being sure that the thimble is flush with the inner flue lining, secure the thimble in place with refractory mortar. The thimble should be surrounded on all sides with 8 inches of brickwork (solid masonry units) or 24 inches of stone.

Install the stovepipe as far as possible into the thimble, but not past the inside of the flue lining. There should be a small airspace (approximately 1/2 inch) between the stovepipe and thimble, allowing for expansion of the stovepipe. Seal this airspace with high-temperature caulking or ceramic wool. Finally, be sure to wire the damper closed and apply the same sealant you used at the stovepipe and thimble junction.

Do not use the Type B installation (not illustrated in this manual), that is, venting up through the fireplace opening, regardless of whether the fireplace opening is closed.

Masonry chimneys have several positive attributes: If properly built, they are quite durable, and most homeowners consider them more attractive perhaps than an unenclosed factory built chimney. And, if the chimney is located within the confines of the house (that is, not attached to an exterior wall), its mass alone will store heat longer and continue to release the heat long after the fire has died. Masonry chimneys have many disadvantages though. Masonry chimneys constructed on an exterior wall are exposed to cold outdoor temperatures, promoting greater heat loss, higher accumulations of creosote, and reduced draft which leads to poorer heater or furnace performance.

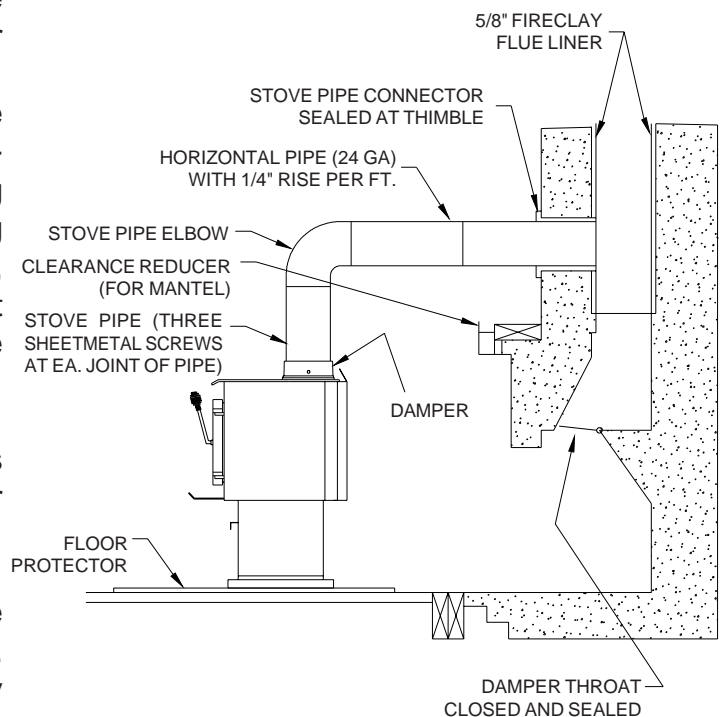

Fig. 7

# RULES FOR CONNECTOR PIPE INSTALLATION

1. Crimped end of the pipe must be installed toward the heater. The pipe should slide inside the flue collar. The pipe should be firmly attached to the flue collar with 3 screws and sealed with furnace cement.
2. Slope any horizontal pipe upward toward the chimney at least 1/4 " inch for each foot of horizontal run.
3. You must have at least 18" inches clearance between any horizontal piping and the ceiling.
4. The pipe cannot extend into the chimney flue.(Fig. 8)
5. Seal each connector pipe joint with furnace cement. Also seal the pipe at the chimney.
6. Use 3 sheet metal screws at each joint to make the piping rigid.
7. It is recommended that no more than two (2) 90 degree bends be used in the stove pipe installation as more than two (2) may decrease the amount of draw and possibly cause smoke spillage.
8. The chimney connector must not pass through an attic or roof space, closet, or any concealed space, or floor, ceiling, wall or combustible construction.

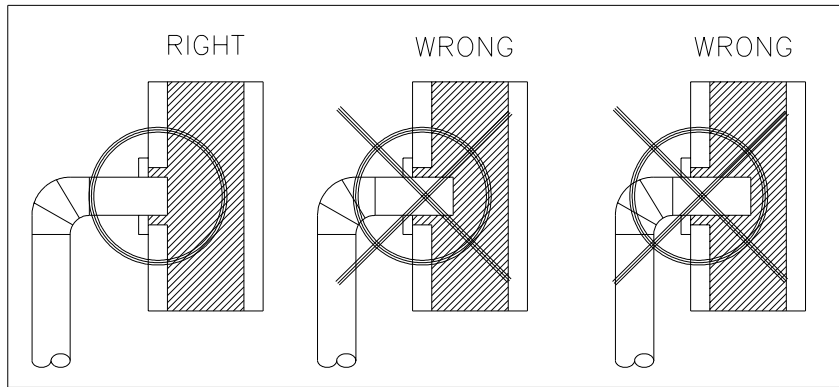

Fig. 8

# OPERATING INSTRUCTIONS

## Wood Fuel

Use Hardwood that has been split and air-dried to obtain maximum burning efficiency.

## Lighting Instructions

1. Open door and place paper and kindling in the firebox.
2. Light the fire and close the doors until the kindling is burning.
3. Open the doors and add fuel as desired.

## Extended Operation

1. Fuel should be added in small amounts to give more complete combustion and uniform room temperature.
2. Empty the ashes regularly. Do not allow ashes to build up. Dispose of hot ashes properly in a metal container with a lid.

# SERVICE HINTS

Do not expect a heater to draw. It is the chimney that creates the draft. Smoke spillage into the house or excessive buildup of water or creosote in the chimney are warnings that the chimney is not functioning properly. Correct problem before using heater. Possible causes are:

1. The connector pipe may push into the chimney too far, stopping the draft. (Fig. 8)
2. Do not connect two heaters into the same chimney flue.
3. The chimney used for a heater must not be used to ventilate the cellar or basement. If there is a cleanout opening at the base of the chimney, it must be closed tightly.

# CHIMNEY MAINTENANCE

## Creosote - Formation and Need for Removal

When wood is burned slowly, it produces tar and other organic vapors, which combine with expelled moisture to form creosote. The creosote vapors condense in the relatively cool chimney flue of a slow burning fire. As a result, creosote residue accumulates on the flue lining. When ignited this creosote makes an extremely hot fire.

The chimney connector and chimney should be inspected at least twice monthly during the heating season to determine if a creosote buildup has occurred.

**WARNING!**  
**NEVER STORE FLAMMABLE LIQUIDS, ESPECIALLY GASOLINE. IN THE VICINITY OF THE HEATER.**

**CAUTION!**  
**OVERFIRING THE APPLIANCE MAY CAUSE A HOUSE FIRE. IF A UNIT OR CHIMNEY CONNECTOR GLOWS, YOU ARE OVERFIRING.**

**CAUTION!**  
**NEVER USE GASOLINE, GASOLINE-TYPE LANTERN FUEL, KEROSENE, CHARCOAL LIGHTER FLUID, OR FLAMMABLE LIQUIDS TO START OR "FRESHEN UP" A FIRE IN THE HEATER.**

**WARNING!**  
**OPERATE ONLY WITH THE FEED AND ASH DOORS FULLY CLOSED.**

4. If the chimney is operating too cool, water will condense in the chimney and run back into the stove. Creosote formation will be rapid and may block the chimney. Operate the heater at a high enough fire to keep the chimney warm preventing this condensation.
5. If the fire burns well but sometimes smokes or burns slowly, it may be caused by the chimney top being lower than another part of the house or a nearby tree. The wind blowing over a house or tree, falls on top of the chimney like water over a dam, beating down the smoke. The top of the chimney should be at least 3 feet above the roof and be at least 2 feet higher than any point of the roof within 10 feet (Fig. 6).

If creosote has accumulated, it should be removed. Failure to remove creosote may cause a house fire. Creosote may be removed by using a chimney brush or other commonly available materials.

Chimney fires burn very hot. If the chimney connector should glow red, immediately call the fire department, then reduce the fire by closing the damper and pour a large quantity of coarse salt, baking soda or cool ashes on top of the fire in the firebox. **CAUTION:** A chimney fire may cause ignition of wall studs or rafters which you thought were a safe distance from the chimney. If you have a chimney fire, have your chimney inspected by a qualified person before using again.

# REPAIR PARTS FOR 2007

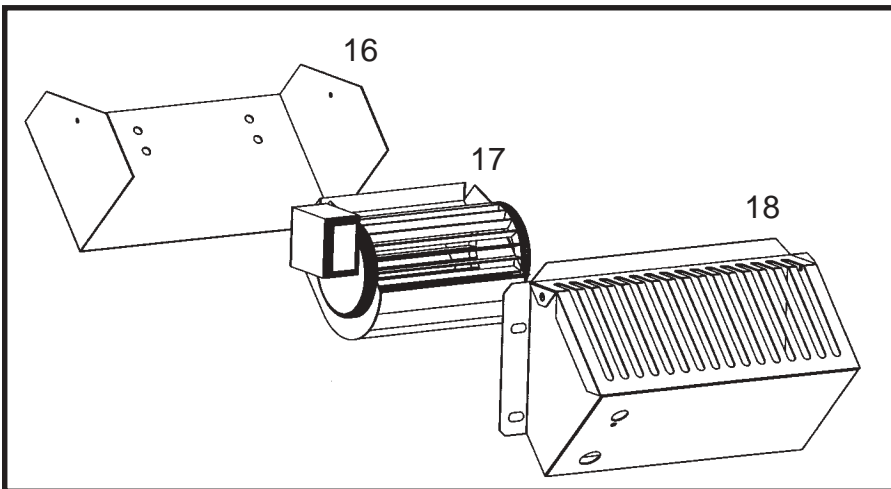
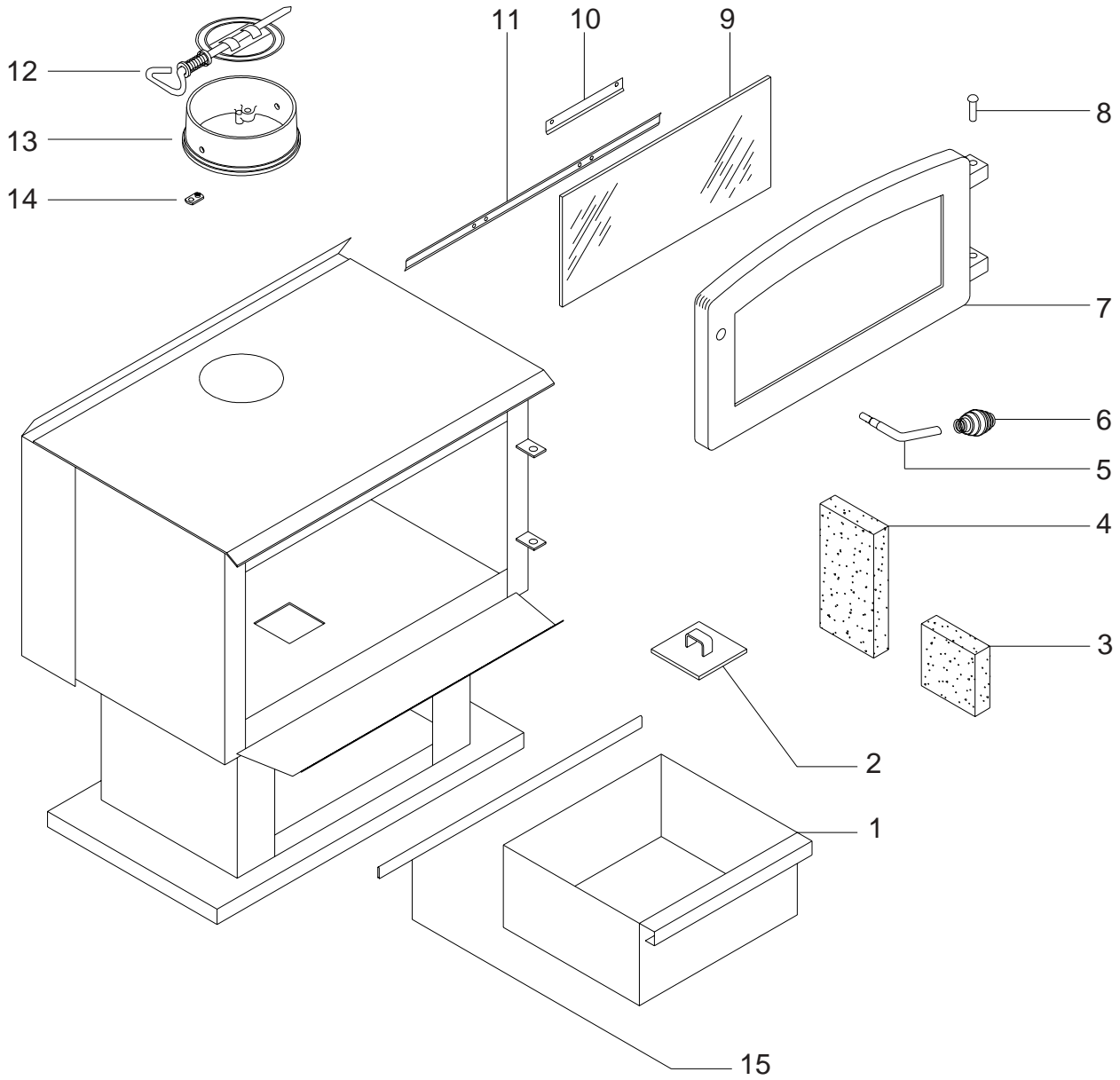

# PARTS LIST FOR MODEL 2007

KEY NO.	DESCRIPTION	PART NO.	QTY.
1	ASH PAN	SE08304-01	1
2	ASH DUMP COVER	SE08602	1
3	1/2 CERAMIC BRICK	29011	2
4	FULL CERAMIC BRICK	29010	17
5	DOOR HANDLE	8535-01	1
6	BRASS HANDLE	132	1
7	FEED DOOR	PL04636	1
N/S	FEED DOOR GASKET & SILICONE	AC0600	1
8	HINGE PIN	30170	2
9	DOOR GLASS	SE02722	1
N/S	DOOR GLASS GASKET		
10	TOP WINDOW BRACKET	PL02716	4
11	BOTTOM WINDOW BRACKET	PL02715	1
12	CAST IRON DAMPER	2709	1
13	FLUE COLLAR	2708	1
N/S	5/16-18 x 1-1/2 HX HD BOLT	30411	3
14	WELD TAB	30410	3
15	PEDESTAL TRIM	PL04910-01	1
N/S	ASH DUMP HOOK	8309	1
16	BLOWER HOUSING BACK	25089	1
17	BLOWER MOTOR	80442	1
18	BLOWER HOUSING FRONT	25090	1
N/S	BLOWER RHEOSTAT	80090	1

N/S = NOT SHOWN

## WIRING DIAGRAM FOR MODEL 2007

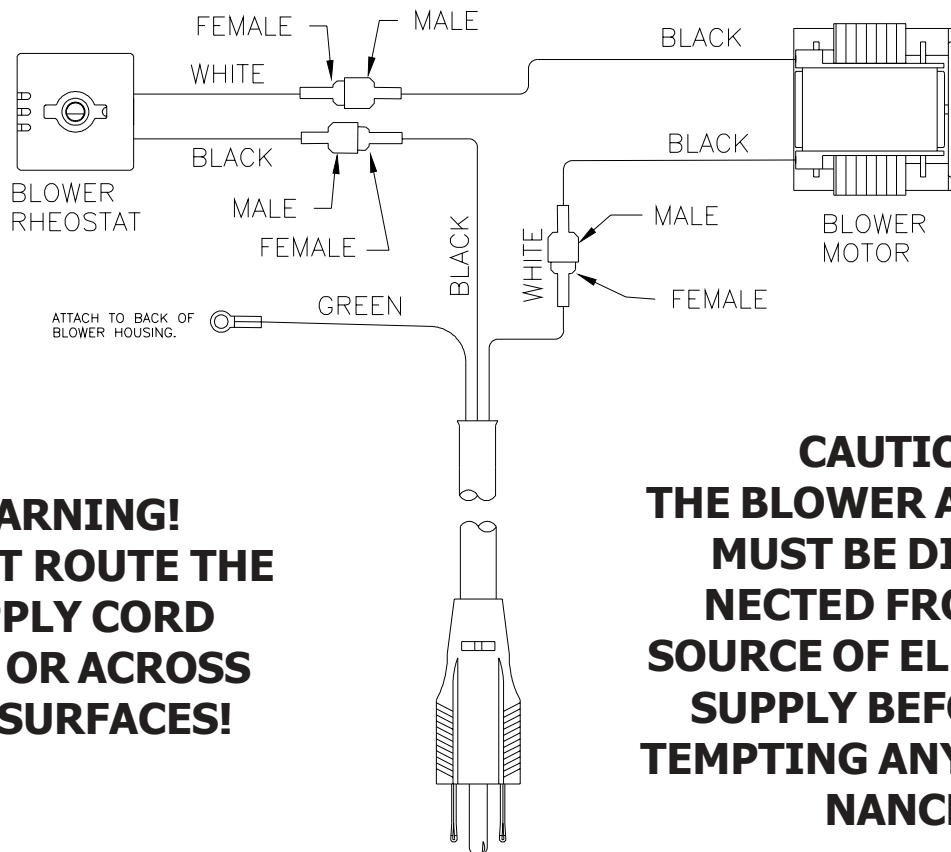

**WARNING!**  
DO NOT ROUTE THE  
SUPPLY CORD  
NEAR OR ACROSS  
HOT SURFACES!

**CAUTION!**  
THE BLOWER ASSEMBLY  
MUST BE DISCON-  
NECTED FROM THE  
SOURCE OF ELECTRICAL  
SUPPLY BEFORE AT-  
TEMPTING ANY MAINTENANCE.

SUPPLY CORD

# **BRICK PLACEMENT - (TOP INSIDE VIEW OF FIREBOX)**

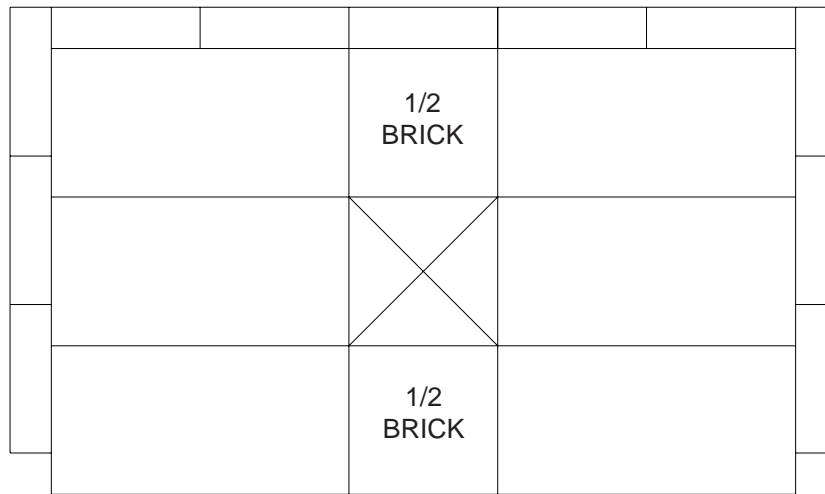

1. INSERT RIGHT & LEFT SIDE FIREBRICK AS SHOWN.
2. INSERT REAR FIREBRICK AS SHOWN.
3. INSERT BOTTOM 1/2 FIREBRICK AND ASH DUMP COVER AS SHOWN.

## **ASHES - REMOVAL AND DISPOSAL**

Ashes should not be allowed to accumulate inside the heater to the point that they obstruct airflow through the burning wood. If ashes obstruct the airflow, poor burning of the wood is likely.

When removing ashes from the heater, wear noncombustible gloves to protect your hands from hot surfaces. Remove the ash dump cover exposing the hole in the bottom of the firebox. Rake ashes through the hole into the ash pan in the pedestal using an ash shovel. Put the ash dump cover back in place before removing the ash pan. Remove ash pan and dump ashes into a safe, noncombustible container. Replace the ash pan after dumping the ashes.

ASHES SHOULD BE PLACED IN A METAL CONTAINER WITH A TIGHT FITTING LID. THE CLOSED CONTAINER OF ASHES SHOULD BE PLACED ON A NONCOMBUSTIBLE FLOOR OR ON THE GROUND, WELL AWAY FROM ALL COMBUSTIBLE MATERIALS, PENDING FINAL DISPOSAL. IF THE ASHES ARE DISPOSED OF BY BURIAL IN SOIL OR OTHERWISE LOCALLY DISPERSED, THEY SHOULD BE RETAINED IN THE CLOSED CONTAINER UNTIL ALL CINDERS HAVE THOROUGHLY COOLED.

Ashes should never be placed in a wooden, cardboard, or plastic container, nor in a paper or plastic bag, no matter how long the fire has been out. Coals have been known to stay hot for several days when embedded in ashes.

NEVER OPERATE THIS HEATER WITH THE BRICK CRADLE OR THE ASH PAN REMOVED OR DAMAGED.

## **GLASS REPLACEMENT INSTRUCTIONS FOR MODEL 2007**

1. Be sure heater has cooled before beginning.
2. Remove 12, 10-24 x 1/4 screws and glass retainers (10, 11) with screw driver.
3. Remove damaged glass (2).
4. To reinstall glass, follow steps 1-2 in reverse order. Be sure to replace the gasket on the glass.
5. Caution: Do not operate with broken glass.
6. When removing broken glass, wear thick gloves, and safety glasses. Keep children away. Discard broken glass.
7. Use part no. 2722 only, to replace broken glass. Glass dimensions (8-7/8 x 20-1/4 x 5mm) high temp resistance glass
8. Warning: Do not slam door or strike glass. Slamming door or striking glass may cause glass to break.
9. Caution: Do not build fire directly on glass.
10. Warning: Do not use abrasive cleaners. Abrasive cleaners may damage the glass.
11. Warning: Do not use substitute Materials.

# NOTES

---

# HOW TO ORDER REPAIR PARTS

**THIS MANUAL WILL HELP YOU OBTAIN EFFICIENT, DEPENDABLE SERVICE FROM THE HEATER, AND ENABLE YOU TO ORDER REPAIR PARTS CORRECTLY.**

**KEEP IN A SAFE PLACE FOR FUTURE REFERENCE.**

**WHEN WRITING, ALWAYS GIVE THE FULL MODEL NUMBER WHICH IS ON THE NAME-PLATE ATTACHED TO THE BACK OF THE HEATER.**

**WHEN ORDERING REPAIR PARTS, ALWAYS GIVE THE FOLLOWING INFORMATION AS SHOWN IN THIS LIST:**

- 1. The PART NUMBER**
- 2. The PART DESCRIPTION**
- 3. The MODEL NUMBER: 2007**
- 4. The SERIAL NUMBER: \_\_\_\_\_**

**UNITED STATES STOVE COMPANY  
227 Industrial Park Road  
P.O. Box 151  
South Pittsburg, TN 37380  
(423) 837-2100  
www.USSTOVE.com**