

WINAUTO



(044)361-05-06

ICQ:495-089-192

(067)469-02-12

ICQ:613-211-859

(099)048-99-03

(093)672-77-76

User's Manual

Car subwoofer Focal Utopia Be 13 WS

In the online store Winauto you also can [buy car subwoofer Focal Utopia Be 13 WS](http://winauto.ua) . Delivery in Kiev and throughout Ukraine with payment upon receipt!

<http://winauto.ua>



Car Receivers - Facia Plates - Head Units - TV and Monitors - Car Antennas - Car Audio - Car DVRs - GPS Navigation - Trip Computers - Security Systems - Mechanical Locking - Car Park Systems - Cameras - Optic and Light - Car Tuning - Car Heating - Marine Audio and Electronics - Car Accessories - Car Isolation - Car Installation Components - Car Batteries - Liquid and Oil -



Utopia Beryllium

the Spirit of Sound

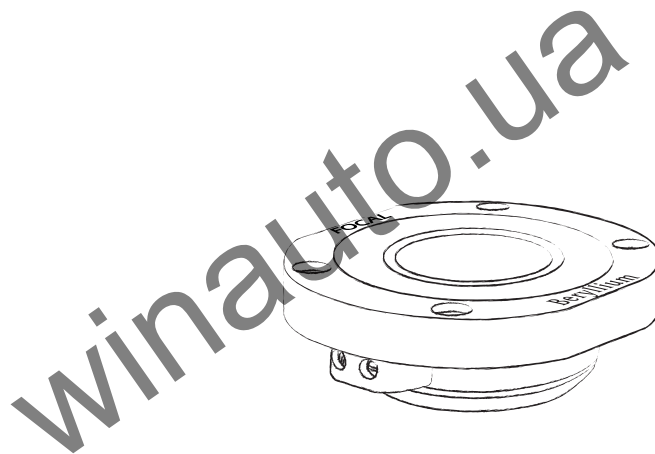

winauto.ua

Summary

	Page
Precautions	4
Utopia Be line: User's manual	5
Tweeters installation	7
Woofers / midranges mounting	9
N° 5 and N°6 Crossblock wiring	13
N°7 Crossblock wiring	15
Crossblock installation	17
N°5 and N°6 Crossblock settings	19
N°7 Crossblock settings	21
Utopia Be Active Kit	23
Subwoofers installation	25
Box enclosure mounting	27
Kits specifications	28
Subwoofers specifications	29
Conditions of guarantee	30
Dimensions	59
International guarantee	61
Notes	63
Serial numbers	64

Precautions

Special precautions regarding the Beryllium dome tweeter

In its solid form, Beryllium is harmless. However, due to its nature, certain special precautions should be observed to avoid exposure to unnecessary risk.

- Under no circumstances the Beryllium dome should be subjected to any form of abrasive action. To ensure no accidental damage to the tweeter dome it is advised to carefully replace the protection cover.
- In the unlikely case of damage to the dome, of any form, the supplied piece of adhesive tape should be immediately used to seal the whole front surface of the tweeter. The protective cover should then be replaced and also taped securely in place. You should then inform the dealer from whom you purchased the product so that the tweeter can be removed by a professional and returned to the product distributor for replacement.
- If the dome is broken in any way giving rise to loose particles of Beryllium, they should be carefully collected with the use of a supplied adhesive tape and sealed in a zip-top bag to be returned with the tweeter.

For further information, please contact Focal-JMLab directly:

beryllium@focal-fr.com

Warning

Continued listening at high volume levels above 110dB, can damage your hearing durably. Listening above 130dB can damage your hearing permanently.

Running-in period

The drivers used in the Uopia Be Line are made up of complex mechanical elements and requires an adaptation period before they deliver their full potential. They must get adapted to the temperature and humidity conditions of their environment. This running-in period depends on the encountered conditions and can last several weeks. In order to shorten this period, we advise you to let your speaker operate for about twenty hours at medium level, playing standard music programs, but with a large amount of bass. Once the components of the speaker are completely stabilized, it is possible to enjoy the real performances of your speakers.

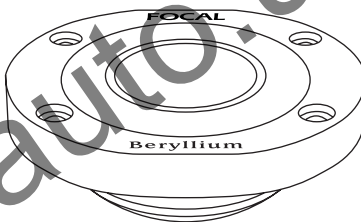

Utopia Be line: User's manual

Congratulations on purchasing a product from the Utopia Be range. We are happy you share our passion for "the Spirit of Sound". Designed using the latest technologies, these speakers continue Focals perfectionist beliefs, developing products with high power handling, and unrivalled sound quality. To obtain the best results from this product, we recommend that you follow carefully all the information contained in this user's manual.

If not followed correctly any fault observed, may not be covered by the guarantee.

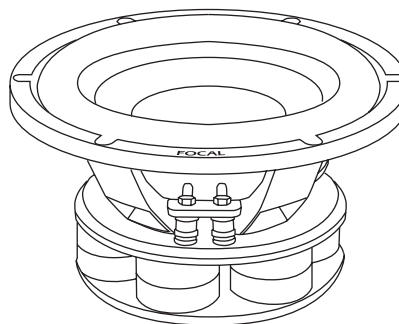
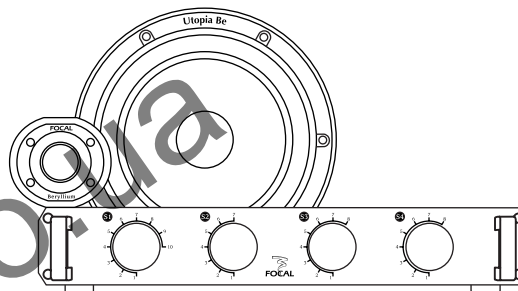

To confirm Focal-Jmlab's guarantee, please register on line on our website: <http://register.focal-fr.com>, or send the guarantee back to us within 10 days of purchase.

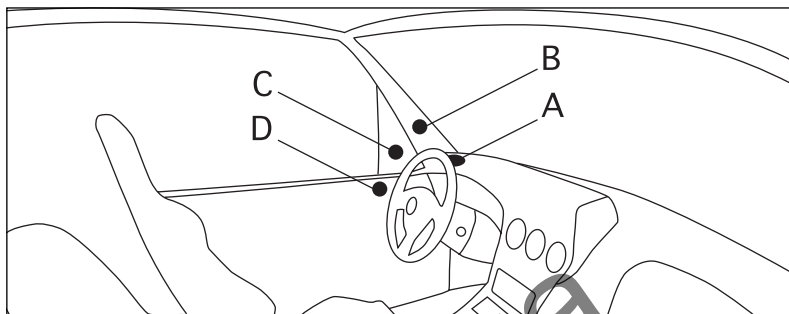

• Fig. 1

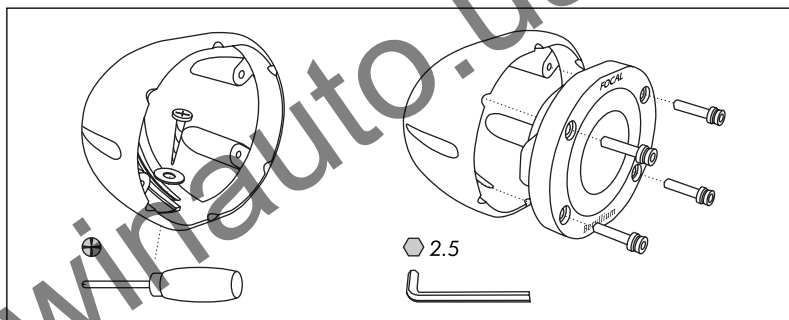

• Fig. 2 and 3

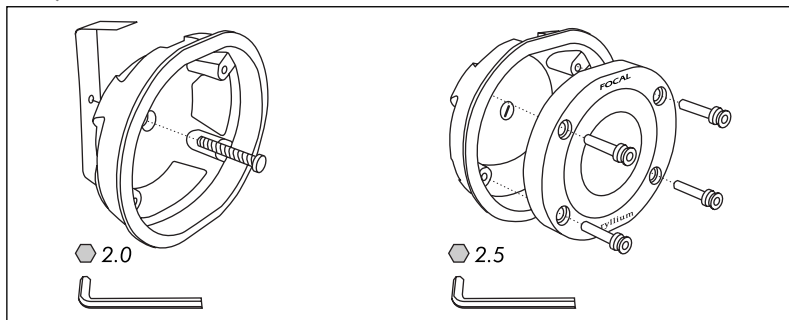

• Fig. 4 and 5

Tweeters installation

Location

The tweeter has been designed for flush mounting (recommended) or surface mounting installation, using the two fixing kits provided. Installation's choice position is extremely important. This is a major factor for high frequency SPL, stability of the acoustics, stereophonic imaging, and overall staging. The standard recommendation for an ideal stereo imaging, is to ensure the "left" and "right" tweeters are installed in the same positions. Also they are approximately at equal distance to the driver (vice-versa for the passenger). Various positions advised should be checked and comparatives made, for an ideal positioning. Tweeter should always be positioned ahead of the normal listening position. The main preferences are the outer positions of the dashboard (*fig. 1, A*), on the windscreen pillars (*fig. 1, B*) (only requires a small amount of install work). The location close to the door mirror (*fig. 1, C*) is also regarded as a good position. Lastly a position high in the door (*fig. 1, D*) is also acceptable even if it is not considered as the best to optimize staging. It is imperative to check before any installation is attempted, that enough space is available (especially for flush-mounting applications). Crossblock (included

in n°5, 6 and 7 kits) contains all necessary functionalities to optimize the tweeter setting, according to its location and vehicle acoustic.

Surface mounting

Surface mounting fixing kit offers various possibilities, thanks to its wave guide which allows different alignments. Fix the assembly using the screw provided on vehicle trim. Don't forget the washer to avoid rubber joint's slide shearing (*fig. 2, 3*). Thread the cable from the tweeter, through the back. Then fix tweeter using the four stainless steel screws.

Flush mounting (highly recommended)

Best results will be obtained by a tweeter flush mounting. Cut trim using tweeter as a mould. Push in the support and ensure it remains flat on the surface. Ensure it is locked in place with the screws supplied. Lock the screw. Thread the cable from the tweeter, through the back, then lock in place the tweeter using the four screws provided (*fig. 4, 5*).

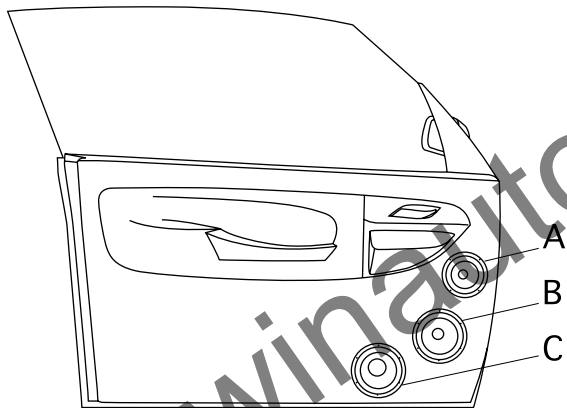

• Fig. 1

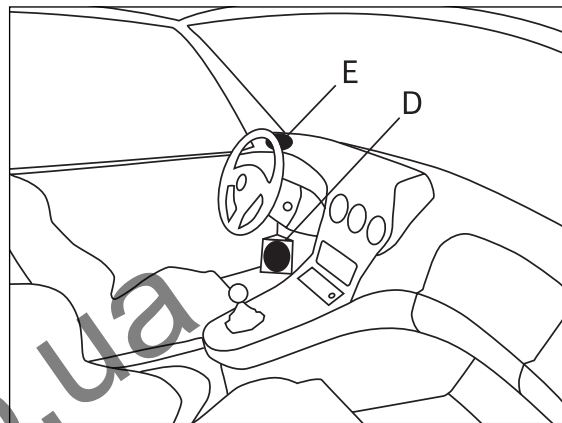

• Fig. 2

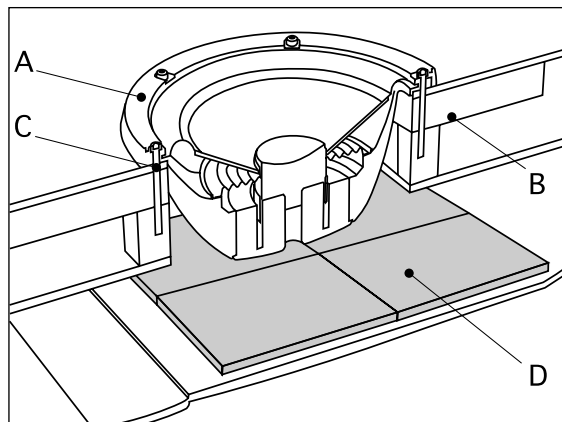

• Fig. 3

Woofers / midranges mounting

Woofers location

Woofers positioned ideally high in the doors (*fig. 1, A*), produce optimal midrange frequencies. Woofers positioned mid in the doors are also a solution to obtain good linearity (*fig. 1, B*). If the woofer-mids are positioned low in the doors (*fig. 1, C*), the loss of midrange will be important. The woofer-mids from the Utopia Be range can also be placed low in the "kick-panels" (*fig. 2, D*) of the vehicle. This is to further optimize the stereophonic imaging and staging. This mounting only suits to Utopia Be 5". Crossblock will allow to obtain a fine setting according to the location.

Midranges location

3" midrange (n°7 Utopia Be kit) is made to be install near tweeter, on dashboard (*fig. 2, E*), in order to have the better staging. 0.5l volume aims at going down to 180Hz.

Mounting advises

Utopia Be woofers and woofer-midranges have been designed for a multitude of vehicles installations. It is worth understanding the basic requirements for installing such products. These woofers and woofer-midranges are able to deliver enormous amounts of energy, during their positive / negative movement. Therefore it is imperative that they be fixed rigid to the desired location (*fig. 3, A*). Resin might be used (*fig. 3, B*). The fixing location should also be strengthened when necessary. Panels should be strengthened to eliminate any unwanted vibrations and screwed on a metallic part of the vehicle (*fig. 3, C*). Such vibrations will drastically reduce the overall performance. These drive units should be fixed and sealed to the baffle or location panel. The use of the foam gasket is advisable for correct air sealing. For added performance, and to better reduce such unwanted vibrations and other acoustical losses, we recommend the use of "plain chant". Easily positioned behind the woofer, on

the metal-work of the vehicle, Plain Chant soaks-up vibrations as well as acoustic reflections. Always ensure before that enough space is available for the magnet assembly, that it doesn't interfere with safety mechanisms or general working parts. In the case of not using the grilles supplied, it is important to ensure the speakers will fit correctly. Ensure there is enough depth behind the speaker has already been explained, but enough thought must also be given for the forward movement of the cone and surround assembly.

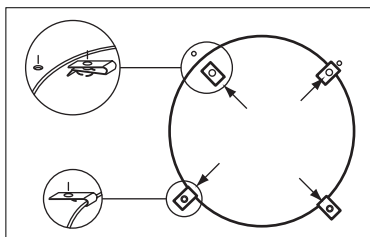

• Fig. 1

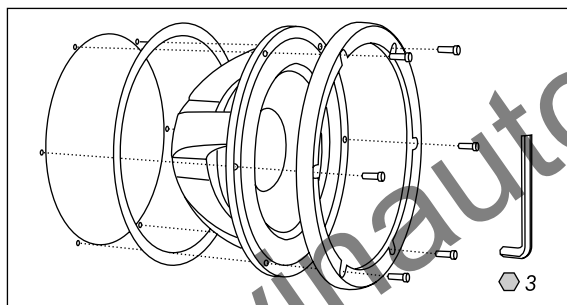

• Fig. 2

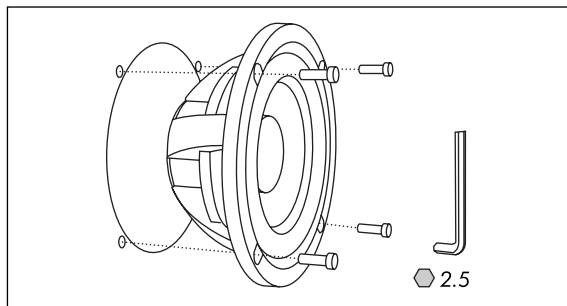

• Fig. 3

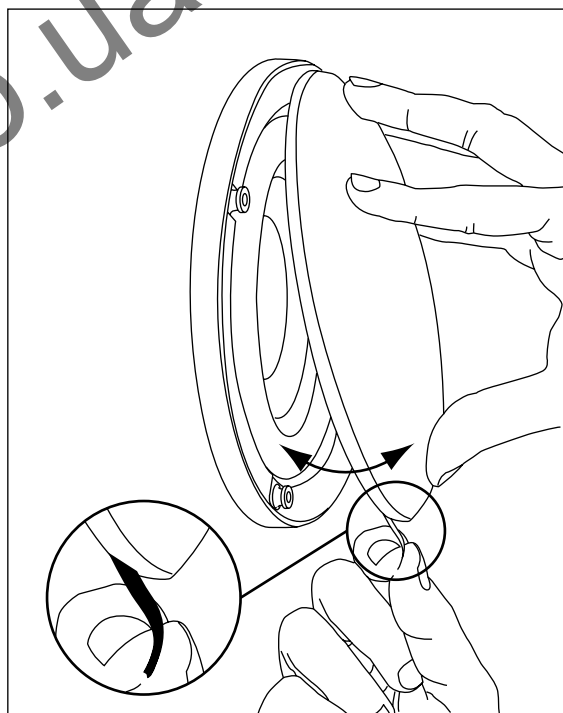

• Fig. 4

Winauto.ua

Woofers / midranges mounting

Woofers

Set up fixing clips to accept the fixing screws later (*fig.1*). Set up the fixing ring, ensuring it lines-up with the fixing clip positions. Fix the foam gasket to the back of the drive unit chassis. Fix with the screws provided. Add the grille, clip on the screws head, then push in place. To remove the grille, pull on the tongue.

Midrange

Set up fixing clips to accept the fixing screws later. (*fig.1*). Set up the fixing ring, ensuring it lines-up with the fixing clip positions. Fix with the screws provided. Add the grille, clip on the screws head, then push in place. To remove the grille, pull on the tongue.

winauto.ua

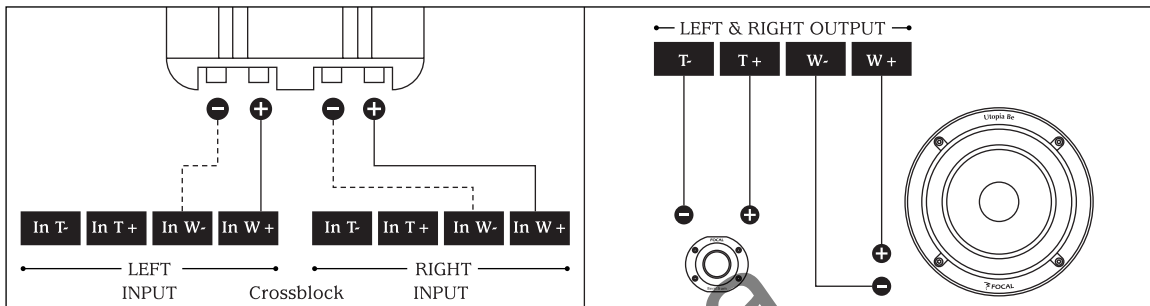

• Fig. 1

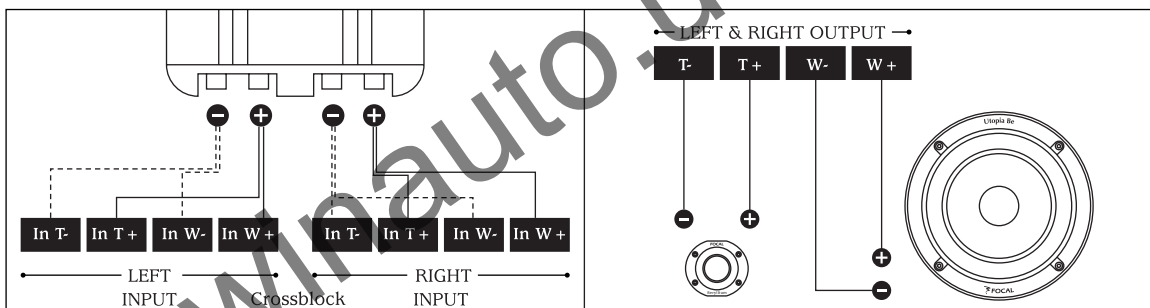

• Fig. 2

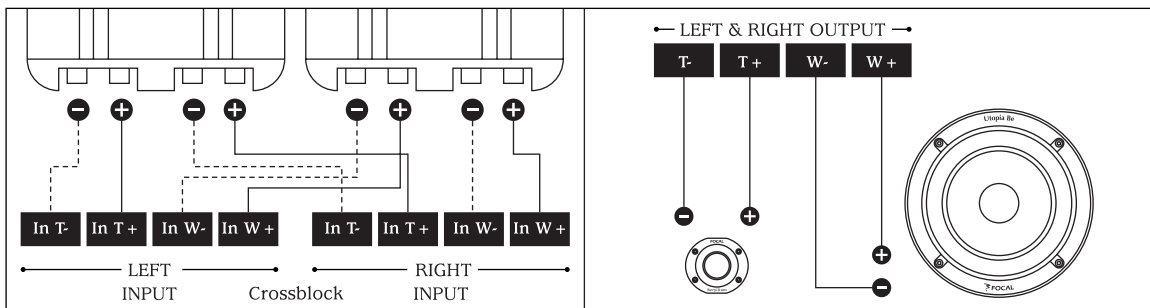

• Fig. 3

N° 5 and N°6 Crossblock wiring

N° 5, 6 Crossblock can be connected to amplifier according to 3 ways:

- **Monowiring:** one cable per speaker's group (*left/right fig. 1*)
- **Biwiring:** two pairs of cables from amplifier to woofer section and tweeter section. This is an interesting solution for high cabling length between amplifier and Crossblock (*fig. 2*).
- **Biamplication:** crossblock is powered separately from woofer and tweeter amplifiers (*fig. 3*).

winauto.ua

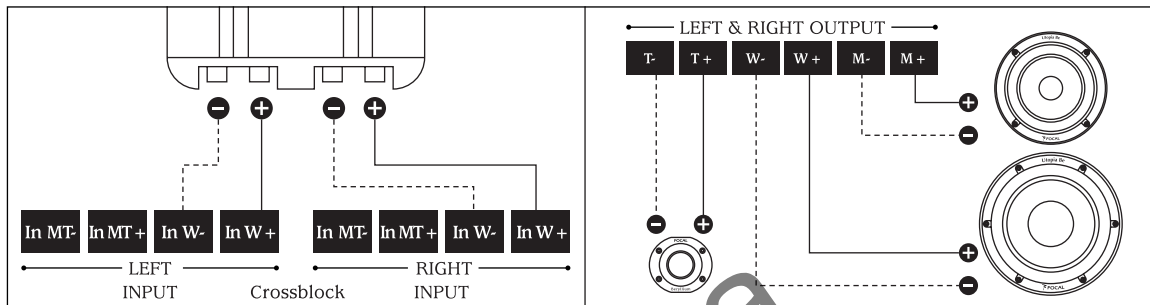

• Fig. 1

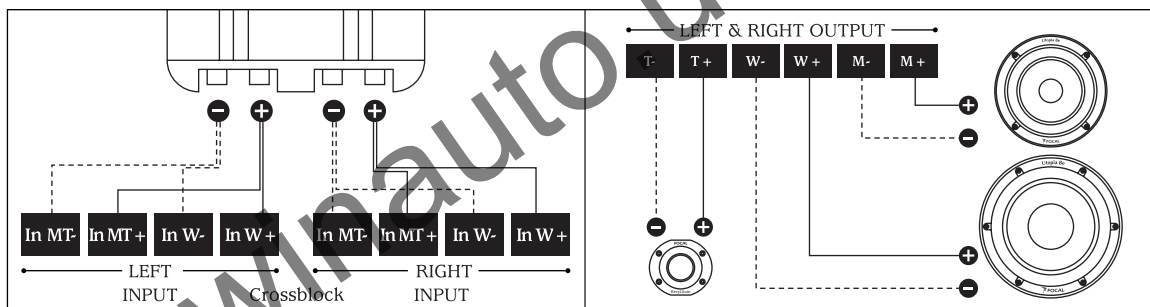

• Fig. 2

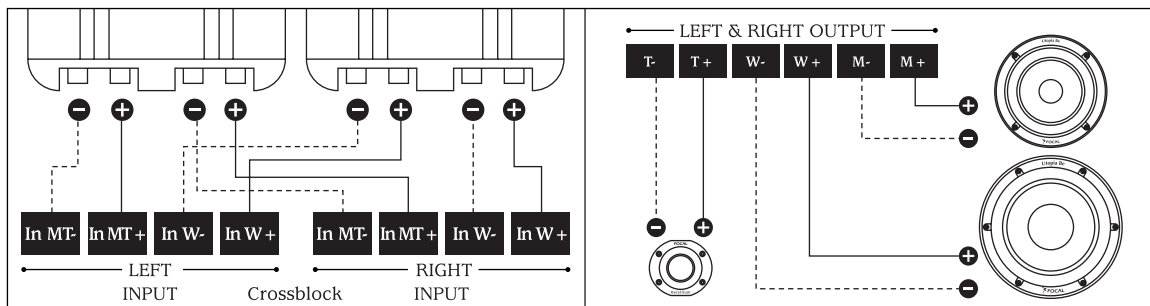

• Fig. 3

N°7 Crossblock wiring

- **Monowiring:** one cable per speaker's group (*left/right fig. 1*).
- **Biwiring:** two pairs of cables from amplifier to woofer section and midrange/tweeter section. This is an interesting solution for high cabling length between amplifier and Crossblock (*fig. 2*).
- **Biamplication:** Crossblock is powered separately from woofer and midrange/tweeter amplifiers (*fig. 3*). Switch the amplifier outputs on "IN" crossover inputs. Switch woofer on "W" inputs, midrange on "M" and tweeter on "T".
- **Warning:** ensure both speaker is wired in phase, thus polarities are respected "+" to "+" and "-" to "-". If not done correctly, a hole or a peak may result, due to a phase reversal. This will dramatically impair the overall performance.

winauto.ua

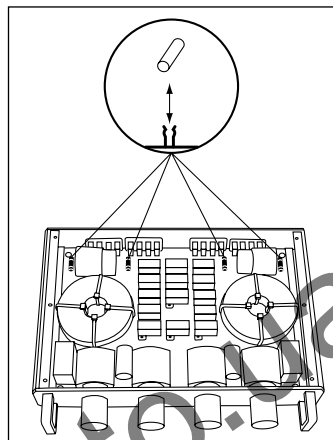

• Fig. 1

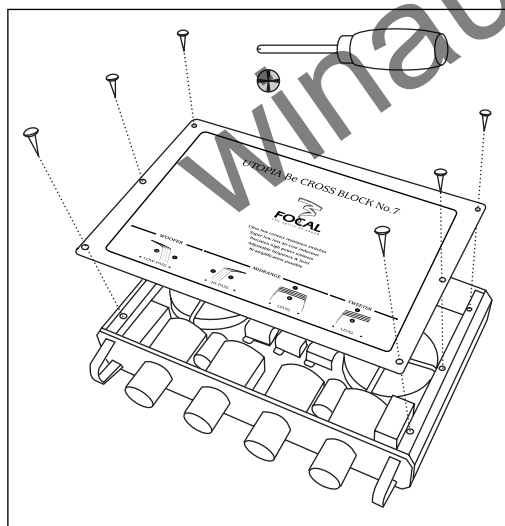

• Fig. 2

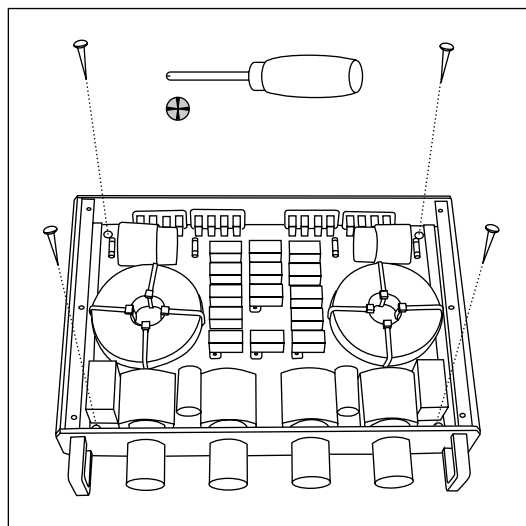

• Fig. 3

Crossblock installation

Warning

When using Crossblock in bi-wiring or bi-amplification, you must remove the 4 jumpers backside, if you don't, you can damage amplifiers (fig. 1). Keep them on for monowiring.



Mounting

To access to Crossover fixing holes, remove the fixing screws (fig. 2). Fix Crossblock with the four screws provided on a perfectly flat area (fig. 3). Please bear in mind that you must keep enough space at the back of the Crossblock to easily access the cables.

winauto.ua

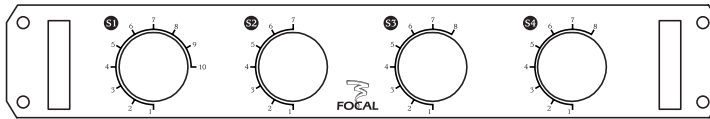

• Fig. 1

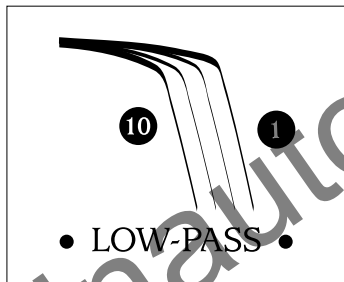

• Fig. 2

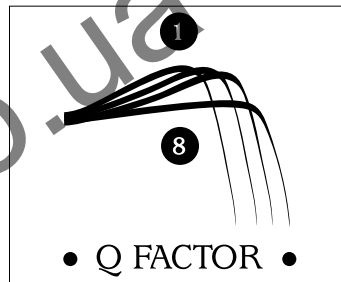

• Fig. 3

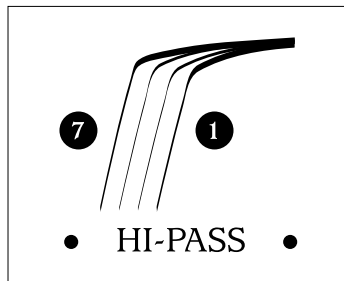

• Fig. 4

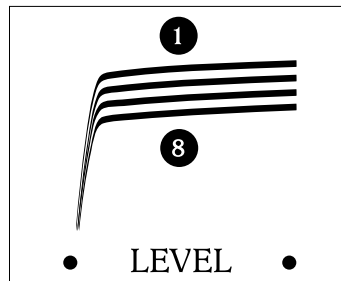

• Fig. 5

N°5 and N°6 Crossblock settings

N°5/N°6 Crossblock is an exclusive high technology crossover offering 4480 different filtering combinations to adapt kit's characteristics to car's environment and to your own tastes. We advise you to refer to the Quality Control Certificate provided with each kit in order to know the reference setting (*fig. 1*).

This setting corresponds to an optimized linearity obtained according to normalized measuring conditions (see file for more informations) and is a good base to refer to before beginning settings. The response curve may change according to vehicle acoustic, speakers location, woofer / tweeter distance and speakers orientation. An adapted Crossblock setting will allow to have a flat response curve. We advise you to use a measure equipment (RTA) for a fine setting. We advise you to note the different settings in order to refer to them as often as you need.

S1 setting (Low-pass)

This setting changes the low-pass frequency value (12dB/octave). "1" refers to the higher value and "10" refers to the lower one (*fig. 2*).

S2 setting (Q factor)

This setting allows to boost midrange. It aims at correcting medium when the woofer is out of the listening axis, low in the door for example, midrange's losses may occur. "8" refers to a linear response whereas "1" refers to maximum midrange's boost (*fig. 3*).

S3 setting (Hi-pass)

This setting changes the hi-pass frequency value (12 dB/octave). Seven settings are available. "1" refers to the higher value whereas "7" refers to the lower one (*fig. 4*).

S4 setting (Level)

It refers to tweeter level setting. Each value change level around 1dB per step. "8" refers to minimum boost whereas "1" refers to maximum boost (*fig. 5*).

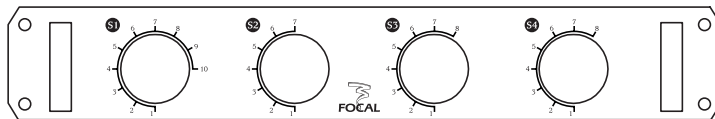

• Fig. 1

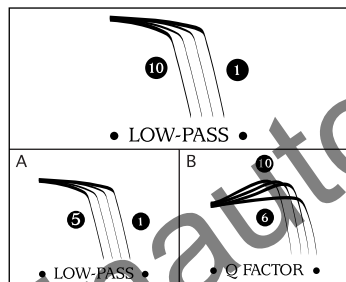

• Fig. 2

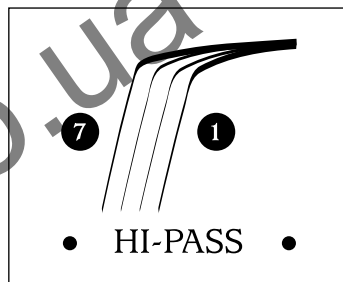

• Fig. 3

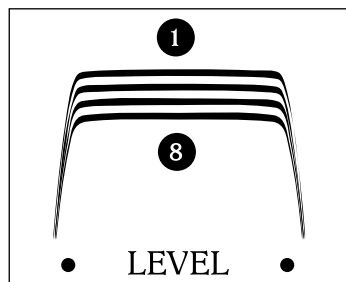

• Fig. 4

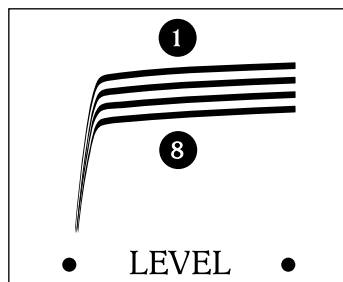

• Fig. 5

N°7 Crossblock settings

N°7 Crossblock is an exclusive high technology crossover offering 4480 different filtering combinations to adapt kit's characteristics to car's environment and to your own tastes. We advise you to refer to the Quality Control Certificate provided with each kit in order to know the reference setting (Fig. 1).

This setting corresponds to an optimized linearity obtained according to normalized measuring conditions (see file for more informations) and is a good base to refer to before beginning settings. The response curve may change according to vehicle acoustic, speakers location, woofer/tweeter distance and speakers orientation. An adapted Crossblock setting will allow to have a flat response curve. We advise you to use a measure equipment (RTA) for a fine setting. We advise you to note different settings in order to refer to them as often as you need.

S1 setting

It combines two settings in one. It changes low-pass crossover frequency values (12dB/octave). Steps "1" to "5" refer to different low-pass frequency values, whereas steps "6" to "10" also refer to the same "1" to "5" values but a boost is included. Steps "6" to "10" are interesting in solving level losses due to woofer location (low in the door for example). Steps "1" and "6" refer to the higher frequency pass, whereas steps "5" and "10" refer to the lower one (fig. 2).

S2 setting (Hi-pass)

This setting changes high-pass frequency values (12dB/octave). Step "1" refers to the higher frequency pass, whereas "7" refers to the lower one. The midrange low-pass value remains fix (fig. 3).

S3 setting (Level)

Midrange level setting according to 8 values, 1dB per step. Step "1" refers to the higher boost whereas "8" refers to the lower one (fig. 4).

S4 setting (Level)

It is the tweeter level setting. Eight steps increase or decrease tweeter level (1dB per step). Step "1" refers to maximum level, whereas "8" refers to minimum one (fig. 5).

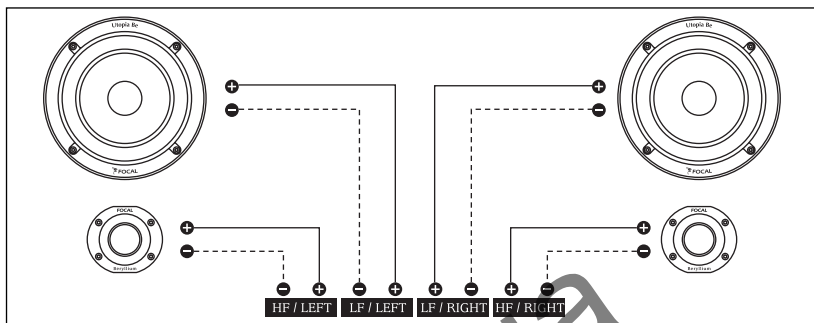

• Fig. 1

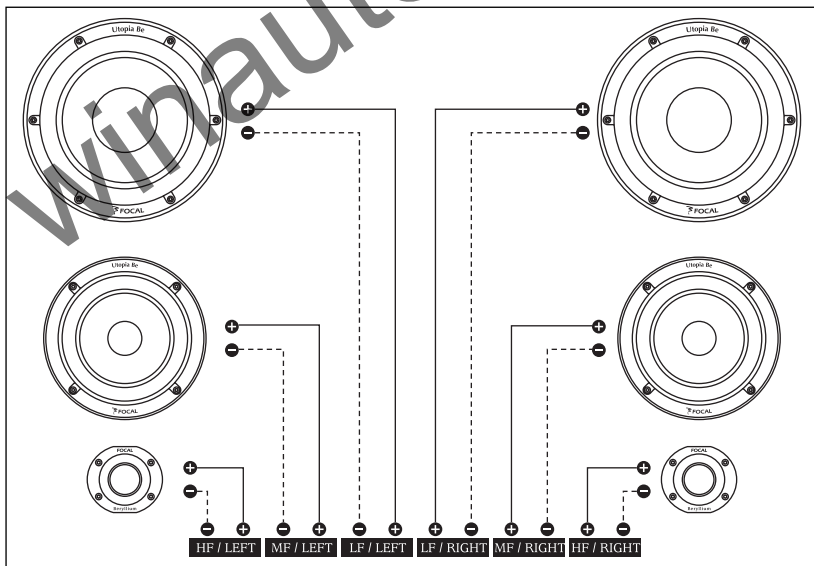

• Fig. 2

Utopia Be Active Kit

Active kits (N°5, 6, 7) are provided without Crossblock crossover in order to allow amplification with active crossover. It is specially adapted to numerous speakers configurations.

N°5 / N°6 active kits wiring

Wire tweeter and woofer on active crossover, then wire crossover to amplifiers. Please bear in mind that you must respect polarities ("+" to "+"; "-" to "-") (fig. 1).

N°7 active kit wiring

Wire tweeter and woofer on active crossover, then wire crossover to amplifiers. Please bear in mind that you must respect polarities ("+" to "+"; "-" to "-") (fig. 2).

Speaker	Recommended minimal cutt-off frequency (high-pass)	Recommended maximal cutt-off frequency (low-pass)
Tweeter Tbe	2.5kHz	full
3 W2 Be	150Hz	6kHz
5 W2 Be	80Hz	4kHz
6 W2 Be	70Hz	4kHz
6 W3 Be	60Hz	1kHz

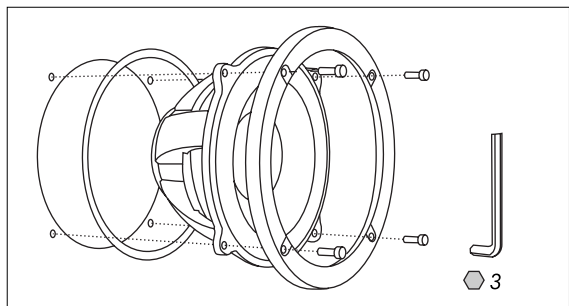

• Fig. 1

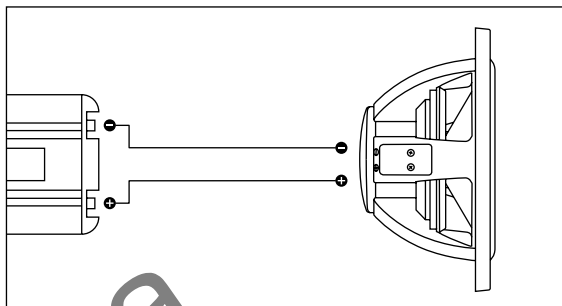

• Fig. 2

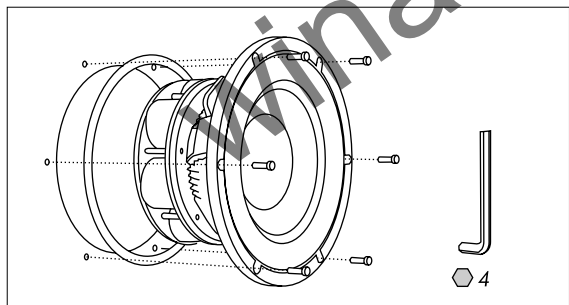

• Fig. 3

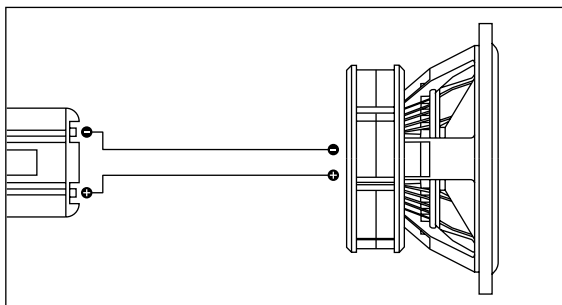

• Fig. 4

Subwoofers installation

Utopia Be line subwoofers are tailored to be installed in small enclosures to allow their installation in the front of the vehicle. The aim is to bring bass frequencies from the back to the front of the vehicle in order to have a better staging. It also aims at allotting critical frequencies (50 to 100Hz) to real speakers tuned to have a maximum of neutrality, dynamic and behaviour.

Subwoofers installation

Each subwoofer kit comes complete with its fixing kit and foam gasket. Cut out and place the driver into position and attached securely in place.

13 WS mounting

Place fixing clips to accept the fixing screws later. (fig.X). Place the fixing ring (*fig. 1*), ensuring it lines-up with the fixing clip positions. Fix the foam gasket to the back of the drive unit chassis. Fix with the screws provided. Add the grille and push in place (clip the grille on screw's heads). To remove the grille, pull on the tongue.

21 WX mounting

Fix the foam gasket to the back of drive unit chassis, then fix with the screws provided. Add the grille and push in place (clip the grille on screw's heads) (*fig. 3*).

To remove the grille, pull on the tongue.

Wiring

You must respect polarities between subwoofer, amplifier and crossover (*fig. 2, 4*).

winauto

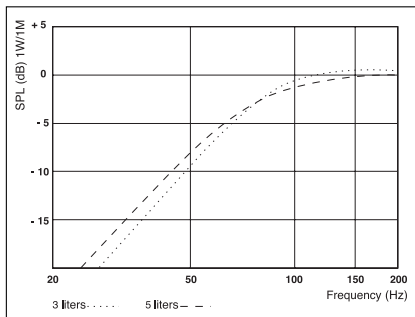

• Fig. 1

13 WS Clos

V (l)	F-3 (Hz)	Q factor
5 liters	76	0.707
3 liters	78	0.82

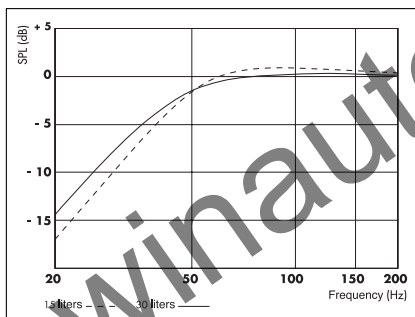

• Fig. 2

21 WX clos

V (l)	F-3 (Hz)	Q factor
30 liters	43	0.77
15 liters	45	0.907

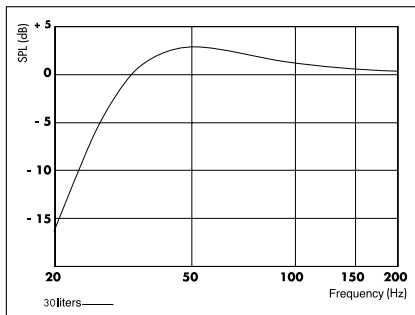

• Fig. 3

21 WX bass-reflex

V (l)	F-3 (Hz)	Fb (Hz)	Port (d x l)
30 liters	29	34	6 x 20 cm

Box enclosure mounting

The correct acoustic load, normally the type of enclosure and volume made available to the subwoofer, is of prime importance for maximum performance. All pistonic acoustic devices require a defined acoustic load to work correctly. This means type of charge (sealed or bass reflex) and volume must be chosen wisely, to gain maximum performance.

Sealed box enclosure

Utopia Be subwoofers have been carefully optimised to work in sealed box enclosure. This type of enclosure ensures sub bass frequencies remain full and controlled. The available excursion of the sub is far more stable, for controlled linearity limiting distortion, ensuring maximum performance is maintained. The added benefit of a properly defined sealed enclosure, is that it remains comparatively small in size. Compared to a defined bass reflex enclosure, which normally has a slight increase in the sound pressure level, Utopia Be subwoofers have improved power handling characteristics. Therefore this slight reduction of level can be compensated with increased amplification (fig 1, 2).a

Bass-reflex enclosure

Bass-reflex enclosure suits to 21 WX subwoofer under conditions. It brings a boost of energy around 50Hz to have dynamic bass. Bass-reflex enclosure distinguishes by an important efficiency in bass and sub bass. Contrary to sealed box, bass-reflex needs a bigger volume. Please follow strckly each instruction (volume, vent size ...) (fig. 3).

Inverse mounting

Because 21WX uses such large impressive multi-ferrite driveunits. You can invert the subwoofer. When choosing inverted mounting, the phase must be inverted, so that the polarity is observed.

Kits specifications

Kit	N° 5 / N° 5 Active	N° 6 / N° 6 Active	N° 7 / N° 7 Active	
Maximum power	150W	200W	200W	
Nominal power	75W	100W	100W	
Sensitivity	89.5dB	91.5dB	89dB	
Frequency response (± 3 dB)	75Hz to 40kHz	66Hz to 40kHz	55Hz to 40kHz	
Nominal impedance	4 Ohms	4 Ohms	4 Ohms	
Tweeter	TBe	TBe	TBe	
Cone	Pure Beryllium inverted dome	Pure Beryllium inverted dome	Pure Beryllium inverted dome	
Magnet	Neodymium	Neodymium	Neodymium	
Resonant frequency (Fs)	1294Hz	1294Hz	1294Hz	
DC resistance (Re)	6 Ohms	6 Ohms	6 Ohms	
Woofers/midrange	5 W2 Be	6 W2 Be	3 W2 Be	6 W3 Be
Cone	"W" composite sandwich	"W" composite sandwich	"W" composite sandwich	"W" composite sandwich
Voice coil (d x h)	32x13mm (1.26x0.5in)	40x15mm (1.57x0.6in)	25x8.5mm (1x0.34in)	40x17mm (1.57x0.7in)
Magnet	Neodymium	Neodymium	Neodymium	Neodymium
Surround	Rubber	Rubber	Rubber	Rubber
Resonant frequency (Fs)	67.47Hz	64.39Hz	188.74Hz	55.28Hz
DC resistance (Re)	3.48 Ohms	2.91 Ohms	3.37 Ohms	3.22 Ohms
Vas	5.23 liters	9.19 liters	0.31 liter	9.92 liters
Qes	0.64	0.79	0.77	0.82
Qms	9.37	14.73	13.79	11.42
Qts	0.6	0.75	0.729	0.765
Sd	86.59cm ²	132.73cm ²	30.19cm ²	132.73cm ²
Bl	5.08N/A	4.95N/A	3.93N/A	5.31N/A
Xmax	3.5mm (0.14in)	4.5mm (0.18in)	2mm (0.08in)	5.5mm (0.22in)
Cut-out diameter	115.50mm (4.55in)	143mm (5.63in)	73mm (2.9in)	14 mm (5.63in)
Mounting depth	63mm (2.48in)	72mm (2.84in)	35.8mm (1.4in)	72mm (2.84in)

Subwoofers specifications

	13 WS	21 WX
Maximum power	300W	500W
Nominal power	150W	250W
Sensitivity	88dB	86.5dB
Cone	"W" composite sandwich	"W" composite sandwich
Surround	Rubber	Rubber
Nom. Impedance	4 Ohms	4 Ohms
VC diameter	32mm (1.26in)	50mm (2in)
VCV height	22mm (0.86in)	25mm (1in)
Xmax	8mm (0.31in)	8.5mm (0.33in)
Magnet	Neodymium	Multiferite (x12)
Gap height	6mm (0.24in)	8mm (0.31in)
Fs	53.43Hz	36.63Hz
Vas	5.24 liters	18.8 liters
Qes	0.52	0.77
Qms	10.09	2.81
Qts	0.495	0.6
Re	3.09 Ohms	3.4 Ohms
Sd	86.59cm ²	208.67cm ²
Mms	17.84g	61.4g
Les	17.70mH	19.19mH
Res	59.96 Ohms	12.41 Ohms
Bl	5.97N/A	7.9N/A

Conditions of guarantee

All Focal loudspeakers are covered by guarantee drawn up by the official Focal distributor in your country.

Your distributor can provide all details concerning the conditions of guarantee. Guarantee cover extends at least to that granted by the legal guarantee in force in the country where the original purchase invoice was issued.

winauto.ua

To confirm Focal-Jmlab's guarantee, please register on line on our website: <http://register.focal-fr.com>, or send the guarantee back to us within 10 days of purchase.