

CARRIED TRACTOR SPRAYERS

**AGS 400EN, AGS 600EN, AGS 800EN,
AGS 1000EN and AGS 1200EN**

INSTRUCTIONS FOR USE

The company AGROMEHANIKA reserves the rights to change the design or change the product without any obligation on informing the client before or after the changes have been made.

Contents:

ES STATEMENT OF CONFORMITY	3
CERTIFICATE OF CONFORMITY	4
1 IN GENERAL	7
2 INSTRUCTIONS FOR SAFE OPERATION AND SAFETY WARNINGS	7
3 LABELS WITH SAFETY PRECAUTIONS AND INSTRUCTIONS FOR USE	15
4 DESCRIPTION.....	18
5 HOW TO CONNECT THE SPRAYER TO THE TRACTOR	22
6 MOUNTING OF THE DRIVE SHAFT (CARDAN SHAFT).....	23
7 DETAILED DESCRIPTION WITH INSTRUCTIONS FOR USE	24
8 ADDITIONAL EQUIPMENT	28
9 FLOW REGULATOR	37
10 PUMPS.....	40
11 SPRAYING GARNITURES.....	43
12 POSSIBLE ERRORS	57
13 TECHNICAL DATA.....	58
14 NOZZLE TYPES IN FARMING.....	63
15 TABLES.....	65



SPRAYER AGS 400EN WITH SPRAYER GARNITURE 12MRX



SPRAYER AGS 800EN WITH SPRAYER GARNITURE 12MY

ES STATEMENT OF CONFORMITY

Manufacturer:

**AGROMEHANIKA, proizvodnja in trgovina Kranj d.d.
Hrastje 52 a, KRANJ, SLOVENIJA**

declares that the products:

**SPRAYER AGS 400 EN
SPRAYER AGS 600 EN
SPRAYER AGS 800 EN
SPRAYER AGS 1000 EN
SPRAYER AGS 1200 EN**

is manufactured in accordance with:

- 1. Directive on Machinery 2006/42/EC and Directive 2009/127/EC amending Directive 2006/42/EC with regard to machinery for pesticide application;**
- 2. Rules on acquiring certificate on device conformity for apply phyto-pharmaceutical products (Ur.list RS, nr. 37/2001);**
- 3. Rules on changes and amendments to rules on acquiring certificate on device conformity for apply phyto-pharmaceutical products (Ur.list RS, nr. 80/2001);**
- 4. Rules on changes of rules on acquiring certificate on device conformity for apply phyto-pharmaceutical products (Ur.list RS, nr. 80/2002).**

The following harmonized European standards on safety were applied:

SIST EN ISO 4254-1:2013 – Agricultural machinery – Safety – Part 1: General requirements;

SIST EN ISO 4254-6:2010 – Agricultural machinery – Safety – Part 6: Sprayers and devices for distributing liquid fertilizers (ISO 4254-6:2009);

SIST EN ISO 4254-6:2010/ AC:2011 – Correction AC:2011 to standard SIST EN ISO 4254-6:2010;

SIST EN ISO 12100:2011 – Machine safety – General principles of planning – Risk assessment and risk reduction (ISO 12100:2010);

SIST EN ISO 13857:2008 – Machine safety – Safe distances, preventing reach of dangerous areas with upper or lower limbs.

Kranj, 04.09.2014

Director:
Jan Šinkovec

Production Manager:
(Responsible for Technical Documentation)

Matjaž Kuhar, dipl.ing.



CERTIFICATE OF CONFORMITY



UNIVERZA V LJUBLJANI

Biotehniška fakulteta

ODDELEK ZA AGRONOMIJO
CERTIFIKACIJSKI ORGAN
 Katedra za fitomedicino, kmetijsko tehniko,
 poljedelstvo, travništvo in pašništvo

CERTIFIKAT

O SKLADNOSTI NAPRAVE ZA NANAŠANJE FITOFARMACEVTSKIH SREDSTEV

1. IME IN NASLOV DOBAVITELJA

a) ime: **AGROMEHANIKA, proizvodnja in trgovina KRANJ d.d.**

b) naslov: **Hrastje 52 a, 4001 KRANJ**

2. SERIJSKA ŠT. CERTIFIKATA: **UL-BF-53/01 (podaljšanje veljavnosti certifikata)**

3. DATUM IZDAJE CERTIFIKATA: **23. 03. 2012**

4. VELJAVNOST CERTIFIKATA: **23. 03. 2017**

5. IDENTIFIKACIJA PROIZVODA

a) proizvajalca izdelka: **AGROMEHANIKA, proizvodnja in trgovina KRANJ d.d.**
Hrastje 52 a, 4001 KRANJ

b) oznaka modela ali tipa: **Škropilnica**

AGS 400 EN, AGS 600 EN

6. TEHNIČNI PREDPISI, STANDARDI IN DRUGE SPECIFIKACIJE NA KATERE SE CERTIFIKAT NANAŠA:

- Pravilnik o pridobitvi certifikata o skladnosti za naprave za nanašanje fitofarmaceutskih sredstev (Ur. list RS št. 37/01)
- Pravilnik o spremembah in dopolnitvah pravilnika o pridobitvi certifikata o skladnosti za naprave za nanašanje fitofarmaceutskih sredstev (Ur. list RS št. 80/01)
- Pravilnik o spremembi pravilnika o pridobitvi certifikata o skladnosti za naprave za nanašanje fitofarmaceutskih sredstev (Ur. list RS št. 80/02, 117/02)

Podpis:
 TEHNIČNI VODJA
 CERTIFIKACIJSKEGA
 ORGANA
 Prof. dr. Rajko Bernik



Podpis:

DEKAN
 Prof. dr. Mihael Jožef Toman



ODDELEK ZA AGRONOMIJO
CERTIFIKACIJSKI ORGAN
 Katedra za fitomedicino, kmetijsko tehniko,
 poljedelstvo, travništvo in pašništvo

CERTIFIKAT

O SKLADNOSTI NAPRAVE ZA NANAŠANJE FITOFARMACEVTSKIH SREDSTEV

1. IME IN NASLOV DOBAVITELJA

a) ime: **AGROMEHANIKA, proizvodnja in trgovina KRANJ d.d.**

b) naslov: **Hrastje 52 a, 4001 KRANJ**

2. SERIJSKA ŠT. CERTIFIKATA: **UL-BF-54/01 (podaljšanje veljavnosti certifikata)**

3. DATUM IZDAJE CERTIFIKATA: **23. 03. 2012**

4. VELJAVNOST CERTIFIKATA: **23. 03. 2017**

5. IDENTIFIKACIJA PROIZVODA

a) proizvajalca izdelka: **AGROMEHANIKA, proizvodnja in trgovina KRANJ d.d.**
Hrastje 52 a, 4001 KRANJ

b) oznaka modela ali tipa: **Škropilnica**

AGS 800 EN, AGS 1000 EN

6. TEHNIČNI PREDPISI, STANDARDI IN DRUGE SPECIFIKACIJE NA KATERE SE CERTIFIKAT NANAŠA:

- Pravilnik o pridobitvi certifikata o skladnosti za naprave za nanašanje fitofarmaceutskih sredstev (Ur. list RS št. 37/01)
- Pravilnik o spremembah in dopolnitvah pravilnika o pridobitvi certifikata o skladnosti za naprave za nanašanje fitofarmaceutskih sredstev (Ur. list RS št. 80/01)
- Pravilnik o spremembi pravilnika o pridobitvi certifikata o skladnosti za naprave za nanašanje fitofarmaceutskih sredstev (Ur. list RS št. 80/02, 117/02)

Podpis:
 TEHNIČNI VODJA
 CERTIFIKACIJSKEGA
 ORGANA
 Prof. dr. Rajko Bernik



Podpis:

DEKAN
 Prof. dr. Mihael Jožef Toman



UNIVERZA V LJUBLJANI

Biotehniška fakulteta



ODDELEK ZA AGRONOMIJO
CERTIFIKACIJSKI ORGAN
Katedra za kmetijsko tehniko

CERTIFIKAT

O SKLADNOSTI NAPRAVE ZA NANAŠANJE FITOFARMACEVTSKIH SREDSTEV

1. IME IN NASLOV DOBAVITELJA

a) ime: **AGROMEHANIKA, proizvodnja in trgovina KRANJ d.d.**

b) naslov: **Hrastje 52 a, 4001 KRANJ**

2. SERIJSKA ŠT. CERTIFIKATA: **UL-BF-168/08**

3. DATUM IZDAJE CERTIFIKATA: **10.06. 2008**

4. VELJAVNOST CERTIFIKATA: **10.06. 2013**

5. IDENTIFIKACIJA PROIZVODA

a) proizvajalca izdelka: **AGROMEHANIKA, proizvodnja in trgovina KRANJ d.d.**
Hrastje 52 a, 4001 KRANJ

b) oznaka modela ali tipa: **Škropilnica**

AGS 1200 EN

6. TEHNIČNI PREDPISI, STANDARDI IN DRUGE SPECIFIKACIJE NA KATERE SE CERTIFIKAT NANAŠA:

- Pravilnik o pridobitvi certifikata o skladnosti za naprave za nanašanje fitofarmaceutskih sredstev (Ur. list RS št. 37/01)
- Pravilnik o spremembah in dopolnitvah pravilnika o pridobitvi certifikata o skladnosti za naprave za nanašanje fitofarmaceutskih sredstev (Ur. list RS št. 80/01)
- Pravilnik o spremembi pravilnika o pridobitvi certifikata o skladnosti za naprave za nanašanje fitofarmaceutskih sredstev (Ur. list RS št. 80/02, 117/02)

Podpis:
TEHNIČNI VODJA
CERTIFIKACIJSKEGA
ORGANA
Prof. dr. Rajko Bernik



Podpis:
DEKAN
Prof. dr. Janez Hribar

Dear customer,

We would like to thank you for your trust, which you have shown by buying the sprayer appliance for chemical plant protection of the company AGROMECHANIKA. The reliability and efficiency of the appliance depends on how you will take care of the appliance. We advise you to read and consider this instruction manual carefully before connecting the appliance to the tractor. This manual contains essential information for efficient use and a long durability of the appliance.

1 IN GENERAL

Your spraying appliance has been designed and constructed for distributing of chemical agents in a water solution that are commonly used for chemical protection of agricultural cultures on the annual agrarian crops. The constructional design of the sprayer allows easy accessibility to the vital parts of the sprayer and even an easier handling. The strong construction, high-quality component parts and loads and loads of additional equipment ensures the user an efficient operation and an optimal consumption of insecticide and energy.

Do not use your sprayer for pumping or spraying of:

- water solutions with a higher specific weight and viscosity than water;
- chemical solutions which should not come in contact with some of the parts of the sprayer;
- drinking water;
- sea water and other salty solutions;
- water which temperature is higher than 40 °C or lower than 5 °C;
- all kinds of lacquer or varnish;
- fast dissolving diluents;
- oil or grease;
- liquids that contain granulates or hard swimming parts.

2 INSTRUCTIONS FOR SAFE OPERATION AND SAFETY WARNINGS

2.1 SAFETY MEASURES



The sign on the left is a safety warning sign. Take special care when you see this sign on your machine or in this instruction manual, since it is a matter of your safety. Follow the rules and instructions for a safe use which are listed bellow.

2.2 CONSIDERING THE SAFETY RULES



Read the instructions considering the safety rules in the operation manual of your machine very carefully. Make sure that the labels on the machine are in good condition and can be well seen. After repairing the machine or replacement of any spare part make sure that all of the labels are fitted on the appliance. Spare labels are available at your authorized seller of the appliances. Learn how your machine is working and how to handle it and its control units.

DO NOT ALLOW UNAUTHORIZED PEOPLE TO USE THE MACHINE!

Make sure that your machine is always in good working condition. Each unauthorized change on the machine can weaken the functionality and/or the safe operation and/or shorten the durability period of the appliance.

2.3 BE PREPARED FOR DANGER



Be prepared for a sudden fire.

Make sure that there is always a first aid kit and a fire extinguisher available while you work. Make sure that the telephone numbers of your personal physician, ambulance, hospital and fire brigade is always kept on a good seen place.

2.4 UNAUTHORIZED PEOPLE

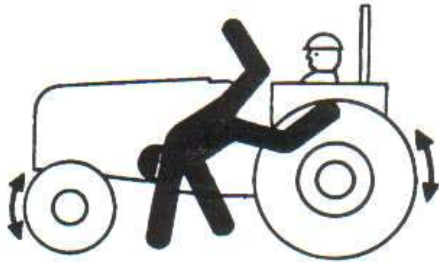

Every unauthorized person who is seating, standing or in any other way driving on the tractor can get hurt (he or she can fall of the tractor or get hurt by the means of the tractor). The person driving on the tractor can have influence on the driver who is operating the tractor or change its centre of gravity. The unauthorized person on the tractor can have influence on driver's sight and can be held responsible for unreliable working conditions on the tractor. Do not allow unauthorized people to be in the immediate vicinity of the machine.

IT IS FORBIDDEN FOR UNAUTHORIZED PERSONS TO RIDE ON THE TRACTOR!

2.5 SAFETY WHEN HANDLING CHEMICAL AGENTS



Be very careful when handling chemical agents and in this way avoid possible injuries or damages done as to you as well as to the environment.

- Be very careful when handling chemical agents. Make sure that you do not come in direct contact with the chemical agents. Chemical agents must be handled in the same way as poison.
- Choose such chemical agents that are the least harmful to your health, the most efficient and easy soluble.
- Always read the instructions for use which are printed on the packaging of the chemical agents. Consider all of the rules and safety instructions, and use the instructions.
- While working always use protection devices for the respiratory organs, such as a breathing mask or a helmet with fresh air.
- Wear appropriate clothes while preparing the chemical agents. Use protection goggles, gloves, boots and protection clothes. Pay attention to your protection equipment. Do not use "worn" protection.
- Make sure that your protection equipment and clothing are in good condition. Dirty gasmasks can cause allergic reactions to the skin. Change the filter regularly!
- Choose "safer" chemical agents. Pay special attention to chemical agents which are not that dusty or do not cause allergic reactions to the skin.
- When choosing chemical agents pay special attention to those which are packed in a "safer" way.

- The preparing of chemical agents should never take place in closed rooms. When preparing chemical agents turn off the machine and in this way lower the risk of spilling the chemical agent.
- The chemical agents should be prepared only in still weather or in a calm place.
- Make sure that your machine is regularly cleaned, since you can in this way lower the chance of a direct contact with the chemicals.
- For preparing and mixing of the chemical agents only tools for this purpose should be used: measuring scale, measuring tools, funnel, bucket. Make sure that the tools are cleaned regularly.
- Do not prepare more of the chemical agents than needed.
- Make sure that your working day in which you are using chemical agents is not longer than 8 hours. Avoid stress and heavy manual work.
- Before spraying and 8 hours after spraying it is recommended not to consume alcohol.
- Do not eat, drink or smoke while working with chemical agents.
- Do not try to clean blocked nozzles with blowing (by means of your mouth).
- Consider the abstinence of the insecticide in the spraying period.
- Immediately wash out your eyes with water if the chemical comes in contact with them.
- After spraying, wash your face and hands thoroughly before eating or drinking.
- Make sure that children and animals can not get to the machine until this one was thoroughly cleaned.
- Clean the machine after using it, put it in an appropriate place and make sure that unauthorized people do not have access to it.
- After using chemical agents wash yourself thoroughly.
- Clean and wash the machine after every single use and before any maintenance work.
- In case you have a certain medical problem in the time while using the chemical agents, consult your personal physician and try to contact the selling agent who is responsible for your chemical agents.
- If you have an accident which involves a chemical agent, we advise you to do the following:
 - eyes and skin: wash with plenty of fresh water;
 - throat and gullet: drink loads of water (no milk!);
 - lungs: fresh air.

2.6 EVALUATION OF DANGER SIGNS ACCORDING TO DANGER

Each chemical agent has a danger sign printed on the packaging which conveys the degree of danger. If possible, avoid chemical agents which have a skull printed on the packaging or include other signs which say that certain chemical agents have an etching effect. Even if a packaging does not include signs of danger that does not mean that the chemical agents is not harmful or dangerous. Although you are using insecticides that have none of the danger signs printed on the packaging we advise you to handle them with extreme care, since they can be harmful to your health in the long term.

Danger signs which can be seen on packaging of chemical agents:



1



2



3



4



5



6

1. poisonous materials – in the case of poisons or very toxic chemical agents;
2. harmful and irritable materials – in the case the chemical agents are harmful to your health and irritating to your skin;
3. corrosive materials – for all chemical agents which have an etching effect;
4. oxidising materials – for all chemical agents which have an oxidising effect;
5. inflammable materials – for all chemical agents which are inflammable;
6. explosive materials – for all chemical agents which can explode.

2.7 MECHANICAL SAFETY



- Do not touch the machine between working!
- Do not remove safety labels or any other safety equipment of the machine!
- Do not exceed the recommended air pressure in the tyres!
- Maintain the tyres regularly!
- If you want to use the machine in the public traffic you must fit it with lights and other illuminates in accordance with the traffic regulations.
- No not enter the reservoir in the time of preparing of the chemical agents or cleaning of the reservoir!
- Never exceed the working pressure of 15 BAR (that is the maximum allowed working pressure on sprayer appliances)!
- Do not start working until you are sure that there are no unauthorized people in the near of the machine!
- Pull out the key from the key-lock after you have finished working and in this way prevent a sudden start of the machine.

2.8 DANGER CAUSED BY LIQUIDS UNDER HIGH PRESSURE



- The liquid which leaks from the pipes can be under high pressure and can cause injuries to your skin, even more; it can cause dangerous injuries if the liquid spreads under your skin.
- Never try to dismount a hydraulic pipe or any other of the hydraulic installation as long as this one is under high pressure. Before you start up the hydraulic system make sure that the installation is safe.
- Help yourself with a piece of cardboard when trying to find the place of leakage. Protect your hands and body by means of gloves and protective clothing if you are handling a high pressure hydraulic system.
- In the case of injury immediately call your personal physician. Each penetration through the skin must be stopped; the liquid must be removed within few hours.

2.9 WORKING PLACE OF THE OPERATOR

- There is only one person needed for operation the machine. This person does not need an assistant. The operator of the sprayer is also the driver of the tractor.
- This machine can be operated by a person who is older than 18 years and has the needed know-how that is needed for a safe and accurate operation of spraying appliances.
- The person needs to be in good health – mentally and physically.
- Operational work and maintaining of the sprayer can be only carried out by authorized personal that has the needed know-how for this type of work.
- The operator of the sprayer must have a medical certificate (in accordance with local regulations).
- The working place of the operator: 1 meter around the machine and tractor.
- While spraying keep the windows and doors of the tractor closed. It is recommended that the operator has a hermetically closed cabin which allows the operator to create overpressure with aeration of fresh air that disables chemically polluted air to enter the cabin.
- While spraying, it is recommended that the operator stays in the cabin for about 90-95% of the time, so the chemical agents can not have influence on his or hers health. Should the operator notice a change in the working of his or hers organs or feel dizzy, he or she should immediately put on the protection breathing mask. However, the best thing to do is to leave the field and look for shelter in a cleaner area.

2.10 PERSONAL PROTECTION



- The operator is advised to use well buttoned clothing and efficient protection equipment while working.
- The operator can come in contact with chemicals through his or her skin, mouth or nose. If you do not work safely even the best protection equipment can not be any use to you.
- A safe working with sprayers requires full attention of the operator, so listening to music (per headphones) while working is not recommended.



WARNING: To prevent inhaling and/or entering the chemicals through the mouth it is recommended not to eat, drink or smoke while working!

2.11 BREATHING PROTECTION

There are many different types of filters available that can protect you against inhaling chemicals.



- It is recommended to use masks that protect the whole face and are fitted with combinations of different filters (filter for gas-smoke). An even more efficient protection can be achieved by means of a protection helmet in which overpressure can be created.
- Make sure that you are using an appropriate filter:
 - A (brown): can be used for most organic chemicals;
 - B (grey): can be used for most inorganic chemicals;
 - P (white): can be used only for liquid or powder chemicals;

- Combination of a brown/white filter with the mark A2P2 in the European Union can be used for most organic chemicals. The mark A2P2 refers to a combination of filters which provide appropriate protection against most gases and vapours that are created by using liquid or powder chemicals. A2 refers to protection class II which means that you can use the filter until it reaches a concentration of 0.5 volume-percentages. P2 refers to gas protection class II.
 - The combination B (grey/white) filter must be used in the case of handling inorganic chemicals.
 - Before using the mask check the tightness and sealing of it. Check the mask for damages and make sure that the outer valve is clean and can be closed without any problems.
- Write down the date of the last usage of the filter. The A2P2 filter must be replaced once a month nevertheless how many times it was used. Filter B must be replaced after every single use! The filter must be used within 6 months after the packaging of the filter was opened. Make sure that used filters are destroyed in accordance with local regulations.
- Never check the efficiency of the filter by smelling:
- certain poisonous elements are odourless,
 - the concentration of the poison can not be always noticed by human nose,
 - smelling of certain elements can damage the nasal mucous membrane.
- Always check the expiring date of the filter.



The filter must be hermetically sealed after usage.

2.12 SKIN PROTECTION

It is recommended to wear the following clothes in order to protect your skin:

- Rubber gloves in order to protect your hands which must be long enough. If the gloves are worn they need to be replaced. Change the gloves after every fifth use. Powder the inside of the gloves.
- Rubber or neoprene boots that are resistant to water and chemicals.
- Overalls that are resistant to water and chemicals and are fitted with a hood. The overall must cover the ends of gloves and boots.
- A waterproof apron for protection of your clothes; in a good protected tractor cabin the apron can be removed.
- A mask that protects the whole face.

Make sure that all of your clothes are well cleaned after every use. Never perform spraying when your clothes are wet, since it can cause a strong contact with your skin. Be very careful in the case your skin gets injured. After handling chemicals always wash your hands with soap and loads of water. After you have finished working also wash your face.

2.13 MAINTENANCE OF THE PROTECTION EQUIPMENT

After every single use thoroughly clean your protection equipment. Wash the mask, boots, gloves and working overall with mild soap water and let them dry.

Store your protection equipment in a dry, cold and clean room. Never store your protection equipment in the same room as the chemicals.

Store your protection clothes apart from other clothes.

Protection equipment that gets dirty between handling chemicals must be cleaned in accordance with regulations on cleaning of dangerous materials.

2.14 SAFE OPERATION

Before starting working the operator must check the correct and safe operation of the machine.

- It is not allowed to sprinkle in foggy and/or rainy weather or when the wind speed exceeds 4 m/s. The direction of spraying must be adjusted to the wind direction.
- If there are two tractors with spraying appliances working simultaneously, they must not pollute each others working area atmosphere. In order to protect your health pay attention to the wind direction and speed.
- Never bring personal things in the area of spraying or when handling chemicals. Before every meal thoroughly clean your hands and face and wash out your mouth with fresh water.
- Before filling in the chemicals check the functioning of the machine by filling the reservoir with clean water.
- The sprayer pump receives the power from the connecting shaft of the tractor by means of the cardan shaft. All of the driving parts can cause bad injuries so in order to avoid that please follow the instructions below:
 - To drive the pump only such a cardan shaft must be used which characteristics are in accordance with the recommendations of the manufacturer and which is fitted with a protection cover.
 - Connect the machine to the tractor only if the drive shaft (P.T.O.) is turned off.
 - Connecting and disconnecting of the cardan shaft must be performed only when the engine is shut off.
 - Before you load the drive shaft (P.T.O.) check the rpm of the engine and make sure that there are no people or animals in the danger area of the machine.
 - The cardan shaft should be cleaned and greased only when the drive shaft (P.T.O.) is turned off, the engine shut down and the start key out of the key-lock.
 - Do not turn on the drive shaft of the tractor (P.T.O.) without a reason and check if the difference between the universal-joint angles is not too big.



Warning! Do not turn on the driving shaft of the tractor (P.T.O.) while the tractor's engine is not running!

2.15 SAFE MAINTENANCE

- Before starting to operate the machine learn how to maintain it. Keep the working place clean and dry.
- Do not grease, maintain or adjust the machine while this is moving! Do not touch moving parts of the machine! Turn off the machine and make sure that there is no working pressure in the circulation of the chemicals!
- Do not maintain or service the machine before this was thoroughly cleaned.
- During maintenance and servicing of the machine turn off the electrical charging by turning the start key or disconnecting the connections.
- Disconnect the drive shaft of the tractor (P.T.O.) in order to avoid a sudden start of the sprayer.
- Do not perform inspections of the machine without turning on the machine's "safety" devices.
- Do not perform welding of the machine if you have used ammonium nitrate or any other liquid that contains ammonium nitrate for spraying without having thoroughly cleaned the machine before.
- Do not enter the reservoir to repair or clean it.
- Support and safely mount all parts that need to be lifted during maintenance.
- Keep all of the sprayer's parts in good condition. Repair eventual damages immediately. Replace worn and damaged parts. Remove excess oil, grease or any other debris.
- Disconnect the battery before you start to adjust the electrical system or perform welding on the machine.

- During maintenance of the machine or cleaning the nozzles use appropriate protection equipment in accordance with the regulations.
- It is strictly forbidden to release chemicals into the environment.

2.16 DRIVING ALONG ROADS AND STREETS

Do not drive around with your sprayer attached to the tractor. If this can not be avoided please consider the following:

- Drive along roads and streets with your sprayer attached to the tractor only when there are no chemical agents in the reservoir. The maximum tractor speed with a full reservoir of water must not exceed 15 km/h.
- Connect the sprayer to the tractor only if the load on the wheels does not exceed the prescribed maximal load. After connecting the sprayer to the tractor at least 25% of weight must be on front wheels. You can achieve these values by adding weights at the front and removing weights at the back of the tractor. Find out how many weights need to be added or removed by means of weighing the tractor before the first use of the sprayer.
- In the case the sprayer completely or partially covers the lights and signs at the back of the tractor you will have to attach some additional lights and signs onto the sprayer.
- Follow the traffic regulations when driving along roads and streets with your sprayer attached to the tractor.
 - Keep the garniture on an appropriate height when driving along roads and streets. In the upper position secure the 3-point suspension of the tractor in order to avoid a sudden fall or slip of the sprayer.

2.17 PROCEDURES IN THE CASE OF ACCIDENTS WITH CHEMICALS

In the case your skin or eyes come in contact with chemicals or their solution, wash them out with plenty of water and repeat the process several times. In the case of suspecting poisoning (symptoms: sweating, dizziness, depression, headache, sickness):

- immediately stop working;
- take off wet clothes;
- remain calm;
- if you feel sick because of consumption of chemicals try to throw up;
- lay on your side;
- immediately call for medical help and let the physician see the label of the chemical agent, so he or she will easier be able to determine the kind of poisoning.

In the case of suspecting poisoning the patient must not eat or drink castor oil, milk, butter, eggs and alcohol, since these ingredients worsen the poisoning effect.





2.18 RULES REGARDING TO USE OF SPRAYING APPLIANCES

The operator and user of the sprayer must be familiar with rules regarding plant protection.

3 LABELS WITH SAFETY PRECAUTIONS AND INSTRUCTIONS FOR USE





You can find certain safety and warning signs in this instruction manual that are also attached to the machine. Take a closer look at them in order to work safely. Follow the instructions and advice concerning precautions listed below.

Make sure that the labels on the machine are in good condition and can be well seen. After repairing the machine or replacement of any spare part make sure that all of the labels are fitted on the appliance. Spare labels are available at your authorized seller of the appliances.

POSITION	SIGN APPEARANCE	DESCRIPTION
1		Sign for maximal pressure on the manometer – red line on the manometer
2		Sign for control elements – 0 closed, 1 opened or arrow for flow direction
3		Sign for rpm of the drive shaft of the tractor (P.T.O.)
4		Identification plate –more on page 19!
5		Sign for reservoir for fresh water which is meant for washing hands
6		Speed limit
7		General safety signs
8		Measuring scale



Learn how to operate the machine well and never allow people to operate the machine who are not familiar with the instructions manual. The table below contains descriptions of different safety signs.

	CE statement of conformity		Warning: presence of poisonous chemical agents!
	Warning: sign that indicates the possibility of personal injuries or damages of the machine!		Warning: maximal allowed pressure in the spraying appliance (12 bar)!
	Warning: keep away from rotating drive shafts!		Warning: maximal rpm and the direction of the driven shaft!
	Warning: read the instruction manual before connecting the appliance to the tractor for the first time!		It is not allowed to clean, grease or maintain the appliance as long as it is running!
	Banned!		It is not allowed to smoke while operating the appliance!
	It is not allowed to remove any of the safety devices from the machine!		It is not allowed to enter the reservoir!
	Recommendations.		If the cabin of the tractor is not constructed in an appropriate way, use your gas mask while working.
	Use protective gloves while working.		Use protection overalls while working.
	Use ear protectors while working (only applies to sprayers).		Water for washing of hands. Warning: this water is not drinkable!

4 DESCRIPTION

Sprayers type AGS 400EN, AGS 600EN, AGS 800EN, AGS 1000EN and AGS 1200EN have a modern design with a thin polyethylene reservoir with rounded edges, smooth inner walls and a sloping bottom. The construction assures a short centre of gravity between the tractor and the sprayer, good insecticide mixing, easy cleaning and complete emptying of the reservoir.

The sprayer consists of: a carrying frame with a polyethylene reservoir and a pouring sieve which are resistant to chemicals, a pump, a flow and pressure regulator, a suction filter, a pressure filter, three-way valves and a lifting mechanism with a lifting gear. The standard equipment includes an additional reservoir for cleaning of the sprayer after finished working and a reservoir for clean water which is meant for washing of hands.

Spraying garnitures 10MRX, 12MRX, 15MRX, 12MY, 12 MY-H and 15MY-E can be connected to all types of sprayers.

The following instructions include detailed information on sprayer's component parts and how to handle them; the second part of this manual includes a catalogue of spare parts.

Since this manual includes information on all sprayer models only pay attention to those parts that refer to your model.

4.1 LIFTING POINTS

When loading or unloading the sprayer onto or from the truck, use the standard lifting points of the three-point lifting system or the bottom of the sprayer (in case of using a fork lift).

4.2 COMPONENTS OF THE SPRAYER



1. frame
2. suction filter
3. three-way valve
4. pump
5. reservoir
6. abluition reservoir
7. clean water reservoir
8. pressure regulator
9. manometer
10. pouring sieve
11. spraying garniture

4.3 IDENTIFICATION NUMBER

The identification number is attached to the underbody, the pump and the spraying garniture.

It includes the following information:

- product type
- model
- serial number
- year of production
- maximum permissible working pressure
- empty weight of the machine
- permissible total weight
- country of origin

When ordering spare parts, all of the information written on the identification plate must be given to the seller.



Sample of an identification plate on a sprayer



Sample of an identification plate on a pump



Sample of an identification plate on a spraying garniture

4.4 FUNCTION SCHEME

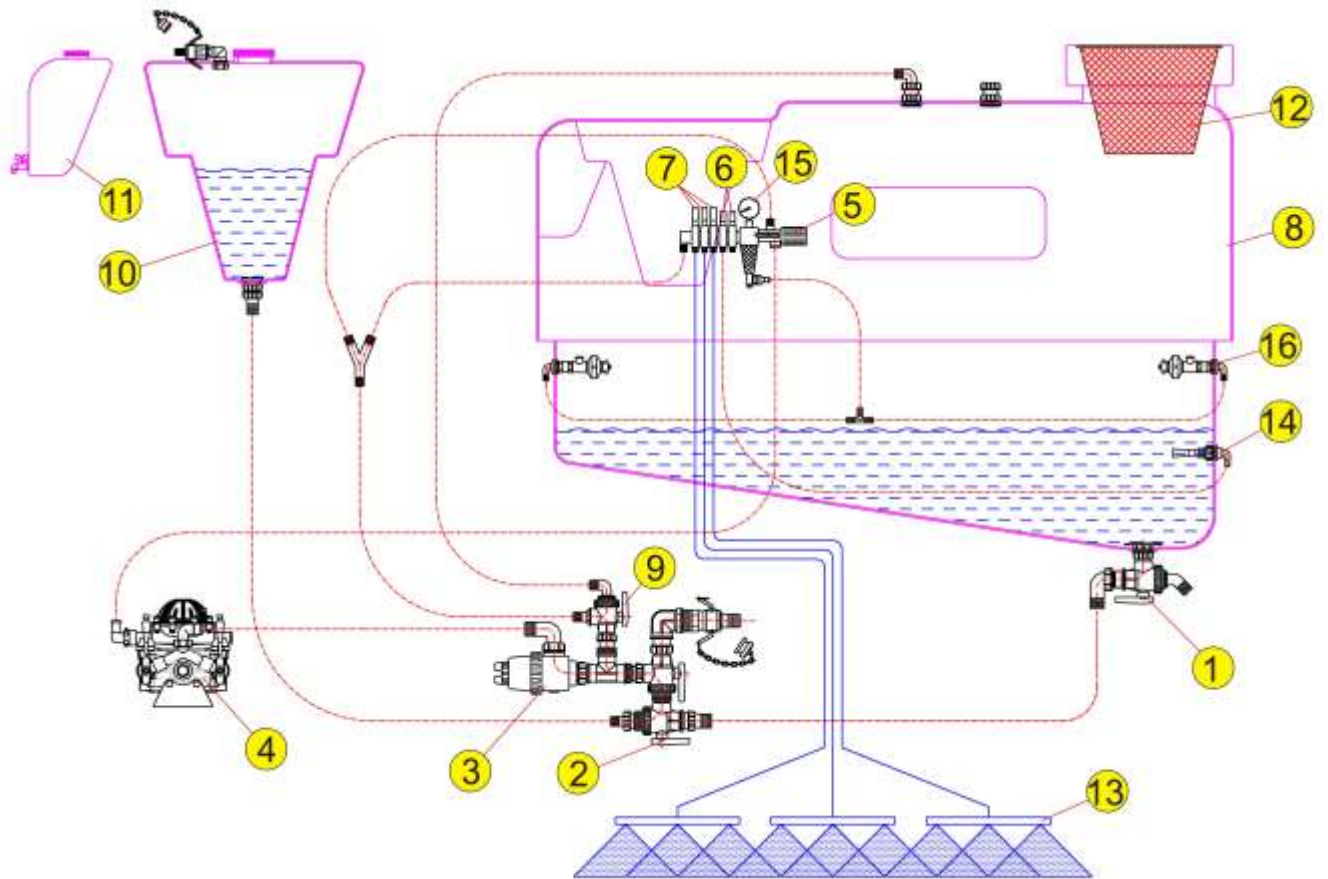

1. Three-way selection valve with release
2. Three-way selection valve
3. Suction filter
4. Pump
5. Pressure regulator
6. Mixing nozzle feeding valve
7. Valves that open individual sections for spraying
8. Main reservoir
9. Selection valve
10. Ablution reservoir
11. Clean water reservoir (to wash hands)
12. Pouring sieve
13. Nozzles
14. Mixing nozzle
15. Manometer
16. Nozzle for tank ablation

4.5 ADDITIONAL EQUIPMENT

There is a long list of additional equipment for your sprayer which will make operation of it even easier:

- hydraulic lifting of the garniture;
- hydraulic levelling of the garniture (tilting of the trapezium);
- filling reservoir (30 l) for filling of the reservoir with insecticide;
- valve for cleaning of the packaging (liquid agents);
- ablation of the insecticide in the sieve;
- TRIGET supports of nozzle inserts;
- nozzle inserts LECHLER, ALBUZ, TEEJET;
- regulation by means of a remote control;
- electrical regulation by means of AG-TRONIK;
- a set for external feeding;
- suction basket with a 5 meter long suction hose;
- washing of the main reservoir;
- a set for central locking of the pressure wire.

5 HOW TO CONNECT THE SPRAYER TO THE TRACTOR

All of the sprayers were designed for connecting to the tractor's three-point connection system class II (pintle diameter 28 mm, picture 6).

Mount the sprayer in the tractor's three-point connection system and secure it with the pins. After that, lift the sprayer to a height where both the connection of the tractor and the sprayer are on the same height and connect them with the cardan shaft.



WARNING: Please consider the weight of the sprayer. Be very careful when lifting a full sprayer for the first time!

We recommend doing the following:

- increase the air pressure in the tyres (see the instructions for use of the tractor);
- make sure that the pressure regulator does not hit the tractor's cabin or any other part of the tractor;
- make sure that the tractor and the pressure regulator are not touching;
- if necessary, attach some weights to the front of the tractor (see the instructions for use of the tractor);
- slow down when driving with a full reservoir (the possibility of breaking the reservoir will become smaller).

6 MOUNTING OF THE DRIVE SHAFT (CARDAN SHAFT)

6.1 OPERATOR'S SAFETY



To avoid possible accidents and personal injuries please follow the instructions and recommendations written below:

- Before mounting (connecting of the cardan shaft to the tractor and the sprayer) the drive shaft – cardan shaft, **always turn off the engine and remove the start key from its lock**. When mounting the cardan shaft, the cardan shaft of the tractor can be easily turned if the engine and the cardan shaft are turned off.
- When mounting the cardan shaft make sure that the safety pin is in right position and well stuck in its hole. Pull and push the cardan shaft forwards and backwards as long as the safety pin is not in its hole.
- Rotating shafts can be very dangerous!
- Always make sure that all of the safety devices are on their place and that all of the rotating surfaces are well covered, including the “junctions” of the cardan shaft on both ends! Do not use cardan shafts without having secured them!
- Do not touch rotating cardan shafts! The safety distance to a rotating cardan should not be less than 1.5 m.
- Protect the protection devices against turning by means of the chain!
- Make sure that the protection of the cardan on the tractor is well connected (attached)!
- Always turn off the engine and remove the start key from its lock before starting maintaining the machine or connecting the cardan shaft!

6.2 CONNECTION OF THE CARDAN SHAFT

The first mounting of the cardan shaft should be performed as follows:

1. Mount the sprayer to the tractor and lift the tractor's lift arms to such a height, where the distance between the tractor's connection shaft and the sprayer's connection shaft is the **shortest (both connection shafts are on the same height)**. Be careful not to hit the sprayer against the tractor or the ground.
2. Stop the tractor's engine and remove the start key from its lock).

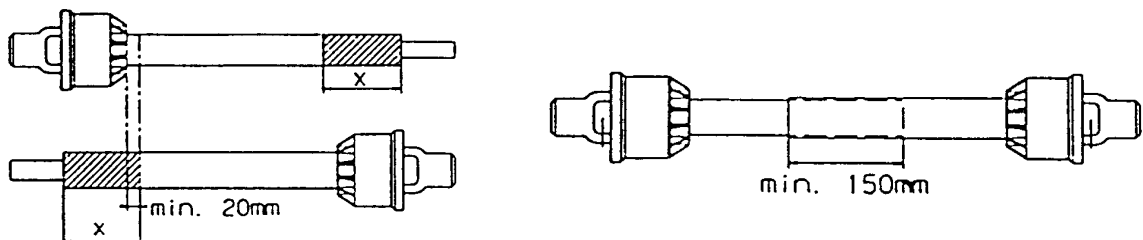

3. Connect the short exiting cardan shaft of the tractor with the short cardan shaft of the sprayer by means of the cardan shaft.
4. In the case the cardan shaft is too long and needs to be shortened, pull out the cardan shaft and mount each end of it separately to the shaft of the tractor and to the shaft of the sprayer, measure it out and mark the place where it needs to be cut.



WARNING: the covering of both cardan shafts must be at least 150 mm.

5. Use an appropriate tool to shorten both parts in the same way and do not forget to remove the swarf.
6. Attach the profiles and join the parts.

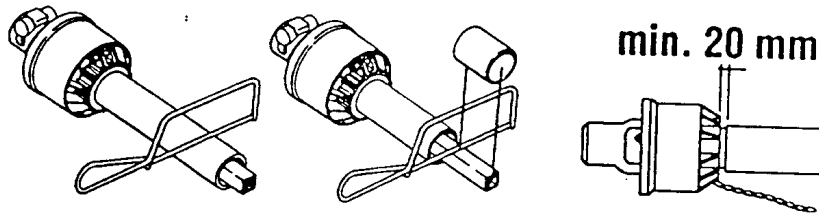

7. Mount the cardan shaft to the tractor and the sprayer.

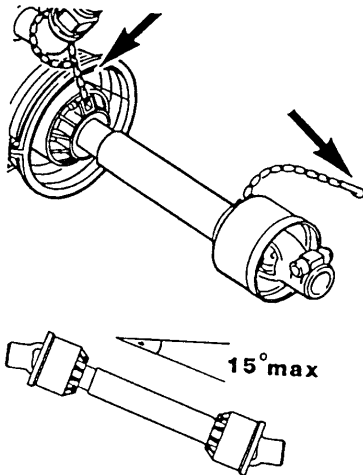

WARNING: Always mount the female end of the cardan shaft to the tractor! Connect the chains in order to avoid rotating of the safety covers!

8. To assure a long reliability of the cardan shaft avoid angles bigger than 15° (picture 8.4).
9. When using safety cardan shafts, the so called “ALLAN’S” bolt must be screwed in with a torque of 40 Nm. Check the torque after 2 minutes of operation.

7 DETAILED DESCRIPTION WITH INSTRUCTIONS FOR USE

The frame is made of a steel welded construction which comprises a reservoir, a pump that is attached to the lower part of the frame, a suction filter and valves for flow regulation. The pressure regulator is attached to the front of the construction, the lifting mechanism to which the spraying garniture is attached to, is located in the back. Both the abluion reservoir and the clean water reservoir are fitted above the main reservoir.

7.1 MAIN RESERVOIR

The main reservoir is made of polyethylene which is resistant to chemicals. It has rounded edges and smooth inner walls for easier cleaning. The reservoir has a sloping bottom which assures a complete emptying of it. There is a sieve with cover mounted on the top of the reservoir. Do not remove the sieve while filling the reservoir with insecticide or water!



WARNING: Use protective gloves when handling insecticides!

A measuring scale is printed on the front side of the reservoir which facilitates the determination of the chemical agent. On the inside of the reservoir, a tube with a red PE ball inside is mounted for easier visual reading of the quantity of the chemical agent inside the reservoir.



The cover consists of two parts. The smaller in the middle of the reservoir is meant for easier filling of water. It is recommended to use clean water. The cover can be opened by turning it to the left and closed by turning it to the right. While operating the machine, the cover must remain closed.



Never put the hose through the opening in the top into the reservoir or do not allow the hose to touch the insecticide, since it can get contaminated! The pressure in the hose can drop and suck in some of the insecticide.



7.2 ABLUTION RESERVOIR

The ablutment reservoir is meant for washing of the reservoir and other elements after you have finished working or after a break. Fill the reservoir with clean water. You can find more detailed instructions in the chapter "DESCRIPTION OF VALVE ADJUSTMENT FOR SPRAYING OR CLEANING".

7.3 RESERVOIR FOR WASHING OF HANDS

This reservoir is meant for washing of hands after handling insecticides. Fill the reservoir with drinkable water. Its capacity is 15 litres.



The water is not drinkable!

7.4 MIXING NOZZLE



The sprayer is equipped with one or two mixing nozzles for better mixing of the mixture. The nozzles are mounted in the lower part of the reservoir. The mixing nozzle is controlled by means of the valve which is mounted on the pressure regulator. The mixing nozzle is operating when the lever of the valve is in upright position and vice-versa. It is recommended to turn on the mixing nozzle during insecticide preparation and driving to the field.

7.5 SUCTION FILTER

The suction filter is mounted between the reservoir and the pump. Its function is to filtrate the insecticide before it reaches the regulator. The size of the filter is 50 MASH.

7.5.1 CLEANING OF THE FILTER INSERT

Firstly, unscrew the yellow lever (3) on the filter cover (2) by turning it counter clockwise and pull it out. The valve mounted inside the filter will close the flow of the liquid from the main reservoir. Unscrew the nut (5) from the filter cover and remove the cover and the filter insert (4). Clean the filter insert and mount all parts back together in the opposite order.

When mounting the parts back together, make sure that the metal pin of the locking valve, which is located at the extracted part (with a yellow handle) will be properly inserted, otherwise the filter will not function properly.

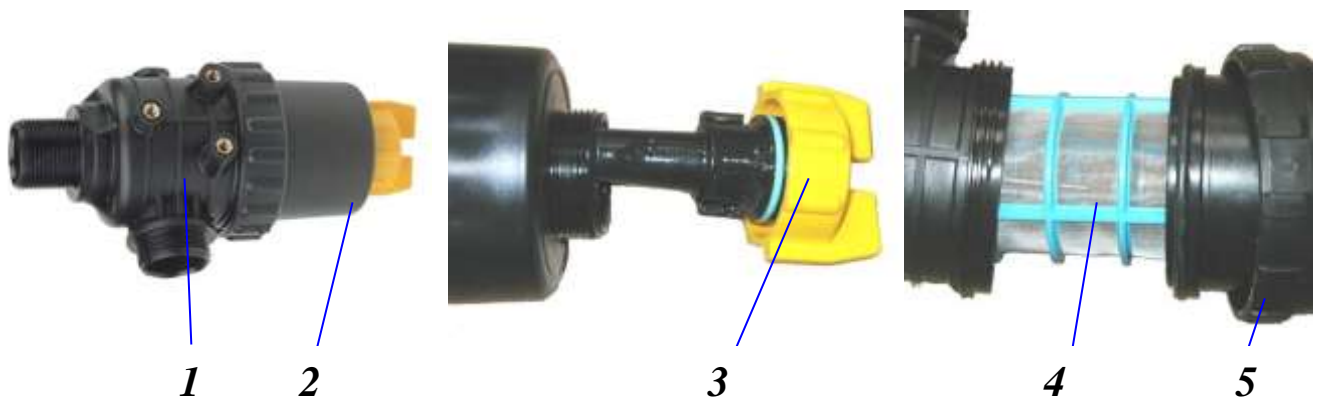

WARNING:

Use protective gloves while cleaning the filter!

Clean the filter insert every time before filling the reservoir!

7.6 NOZZLE FOR CLEANING INTERIOR OF MAIN RESERVOIR



Nozzle is mounted in the interior of main reservoir and is intended for washing of reservoir's interior after finished spraying. It is connected to one of the supply valves on pressure regulator, which, when open, provides required water for cleaning.



Nozzle shape in the figure is illustrative only and can differ from actual state on the sprayer.

7.7 DESCRIPTION OF VALVE ADJUSTMENT FOR SPRAYING OR CLEANING

7.7.1 SPRAYING

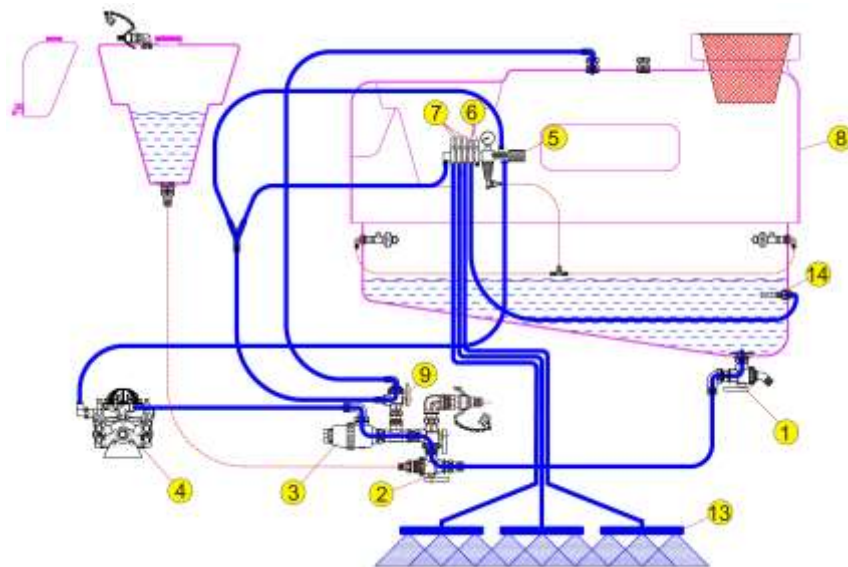

Empty the main reservoir (8) by opening the three-way valves (1) and (2) and let the insecticide flow through the filter (3) and the pump (4) to the pressure regulator (5). Open the valve for insecticide mixing (6) and for individual nozzle sections (7).

The flow direction of the three-way valve is shown on the valve lever by means of an “arrow”. The selection valve (9) needs to be adjusted in such way that the liquid excess is diverted from the regulator to the main reservoir. You can find a more detailed description of the regulator in chapter 10, “The flow regulator”.

7.7.2 COMPLETE CLEANING OF THE SPRAYER

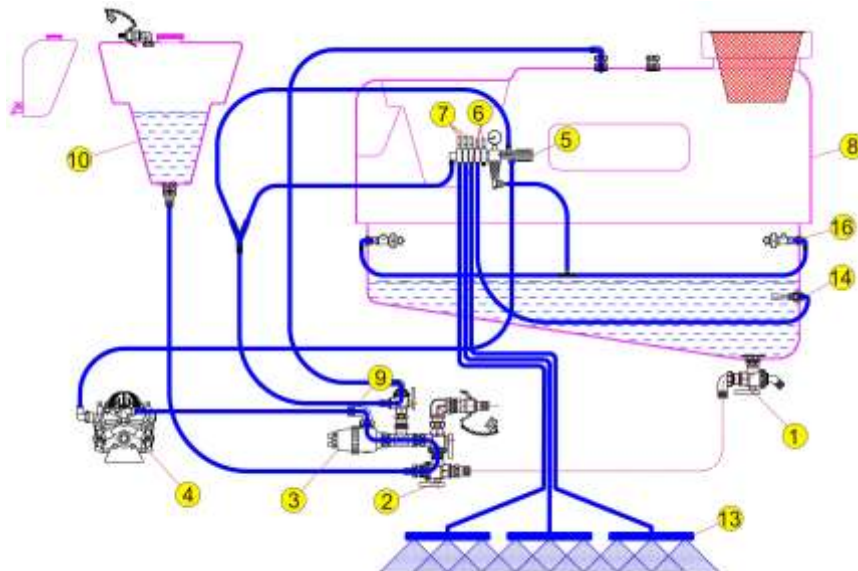

The complete cleaning of the sprayer includes the cleaning of all inner parts of the sprayer: the reservoir (8), the filter (3), the pump (4), the regulator (5), the nozzles (13), etc. Switch the three-way valve (2) to the ablation reservoir (10). Direct the clean water from the reservoir (10) through the pump (4) into the pressure regulator (5). By opening the valves (6 and 7) you enable water to flow to the nozzles and to the mixing nozzle (14). The flow from the pressure regulator through the selection valve (9) should be directed into the main reservoir. At the end of the process, switch the three-way valve (2) to the main position and empty the reservoir through the nozzles (13).

7.7.3 PARTIAL CLEANING OF THE SPRAYER

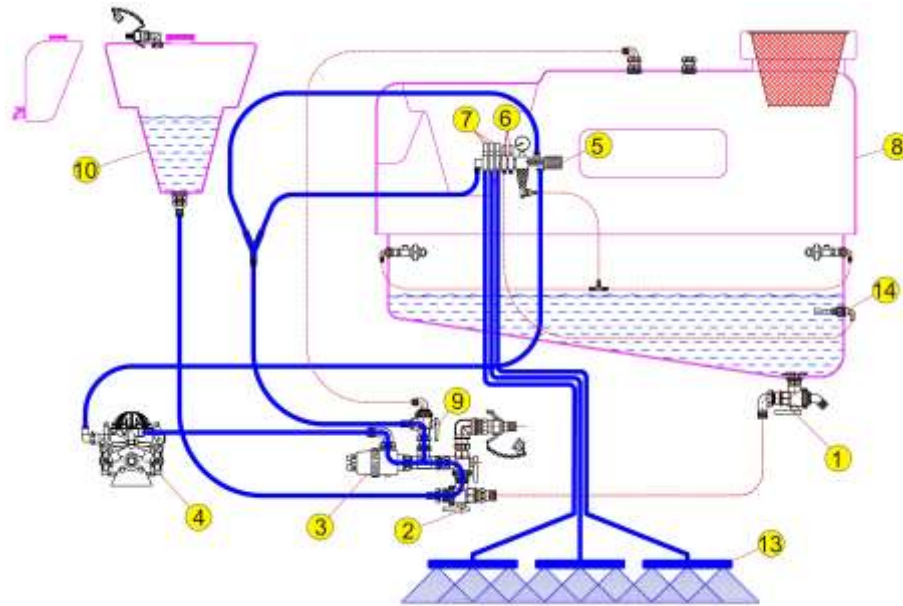

The partial cleaning of the sprayer includes the cleaning of the filter (3), the pump (4), the pressure regulator (5) and the nozzles (13) without changing the concentration of the insecticide in the main reservoir.

Switch the three-way valve (2) to the ablation reservoir (10) and change the flow directly to the pump (4) by means of the selection valve (9). Close the mixing valve (6) by means of the pressure regulator (5) and, if needed, the return line from the pressure filter, too. The clean water can now easily flow through the filter (3), the pump (4), the pressure regulator (5) and through nozzles (13) whereas the concentration of the insecticide in the main reservoir remains the same.

8 ADDITIONAL EQUIPMENT

8.1 SET FOR OUTER CLEANING OF THE SPRAYING APPLIANCE

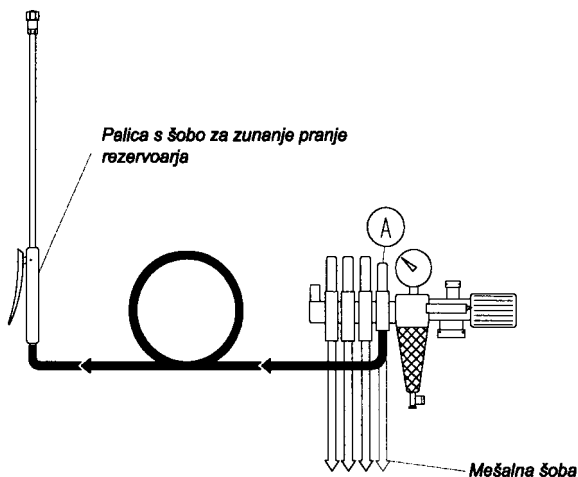

After finished working the spraying appliance needs to be cleaned. The most appropriate place for cleaning is at the edge of the surface where you have had just finished operating the machine. For this purpose, a set for outer cleaning of the spraying appliance is a big help.

The set includes:

- a spraying stick
- a flexible hose and
- an accessory part for connecting the spraying stick to the pressure regulator.

The accessory part needs to be mounted on a free valve of the pressure regulator (if the spraying appliance has a free section mounted) or a section on the pressure regulator needs to be disconnected (e.g. the mixing nozzle) and connect the spraying stick to the spraying appliance.

Other parts of the spraying appliance need to be set the same as for partial cleaning of the sprayer (see chapter 7.6.3).

8.2 WASHING OUT OF THE INSECTICIDE IN THE SIEVE



This additional equipment assures an easier insecticide handling. There is a nozzle mounted in the sieve which directs the flow of the liquid to the bottom of the sieve and, in this way, washes of the insecticide in the sieve. The nozzle includes an additional direction control valve which is additionally mounted on the flow regulator and a hose connection between the valve and the nozzle. The nozzle is operating when the valve lever is in upright position and vice-versa (see chapter 9.5).

8.3 VALVE FOR PACKAGING WASHING

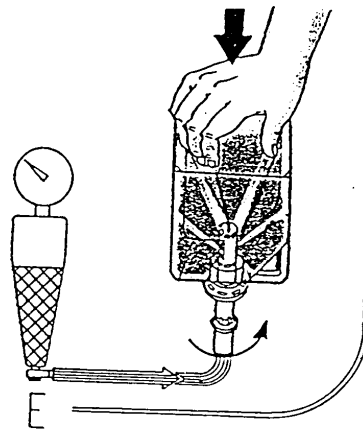

The valve for packaging washing is meant for packaging washing of liquid agents. The valve is mounted inside the reservoir, near the pouring sieve or at the bottom of the pouring sieve. It is connected to the direction control valve at the flow regulator by means of a hose (mostly in combination with the mixing nozzle). If you wish to wash an empty packaging you will need to open it, push it over the nozzle to the limiter and push it than together with the limiter towards the wall of the reservoir or towards the bottom of the pouring sieve. After that, open the valve and the rotating nozzle, which will thoroughly clean the packaging. When removing the packaging, the valve will close the flow of the liquid.



WARNING: Use protective gloves when handling insecticides!

8.4 SUCTION BASKET WITH SUCTION HOSE

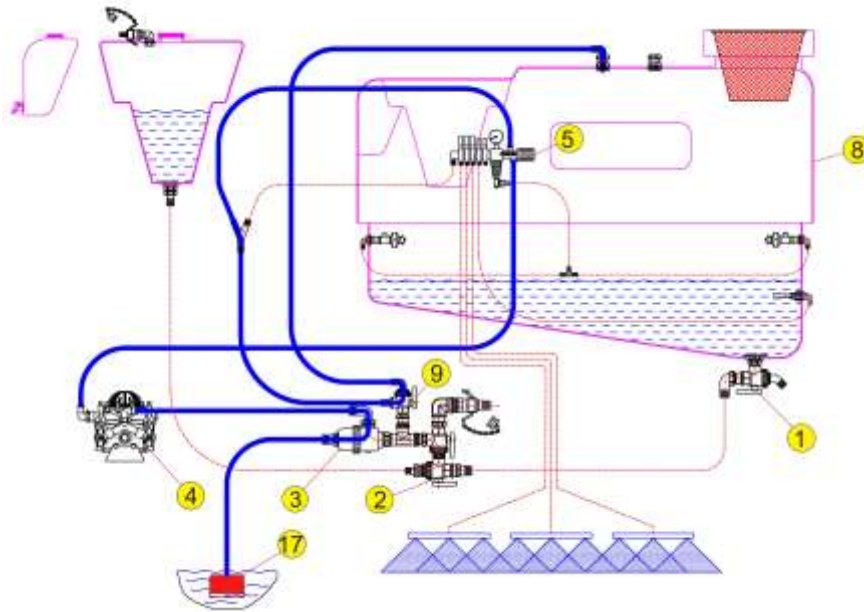

- 1. Three-way valve with release
- 2. Three-way valve
- 3. Suction filter
- 4. Pump
- 5. Regulator tlaka
- 8. Pressure regulator
- 9. Selection valve
- 16. Suction basket with suction hose



The suction basket is meant for sucking of water out of ponds, streams, fountains, etc. through the filter, the pump and the regulator into the main reservoir. It consists of the suction basket, 5 meters of suction hose and a connection piece for the filter. The connection piece is mounted to the suction filter in this way: remove the yellow lever and mount the connection piece that is attached to the suction basket instead of the yellow lever. Stretch the suction hose and plunge the suction basket into water. While doing this, be aware that deeper you sink the suction basket the more this affects the membranes in the pump. The height difference between the pump and the suction point should not be bigger than 3 metres. Before turning on the pump switch the lever of the central valve 2 (see chapter 10, “The flow valve”) to the position “Z” and close the three-way valve at the exit of the reservoir (outflow of the reservoir). The water flow is now directed from the suction basket to the suction filter, the suction pump and the flow regulator (return line) into the reservoir.



WARNING: Be very careful when sucking water out of a pond, since a small inattention can poison the water in it!

8.5 FILLING RESERVOIR

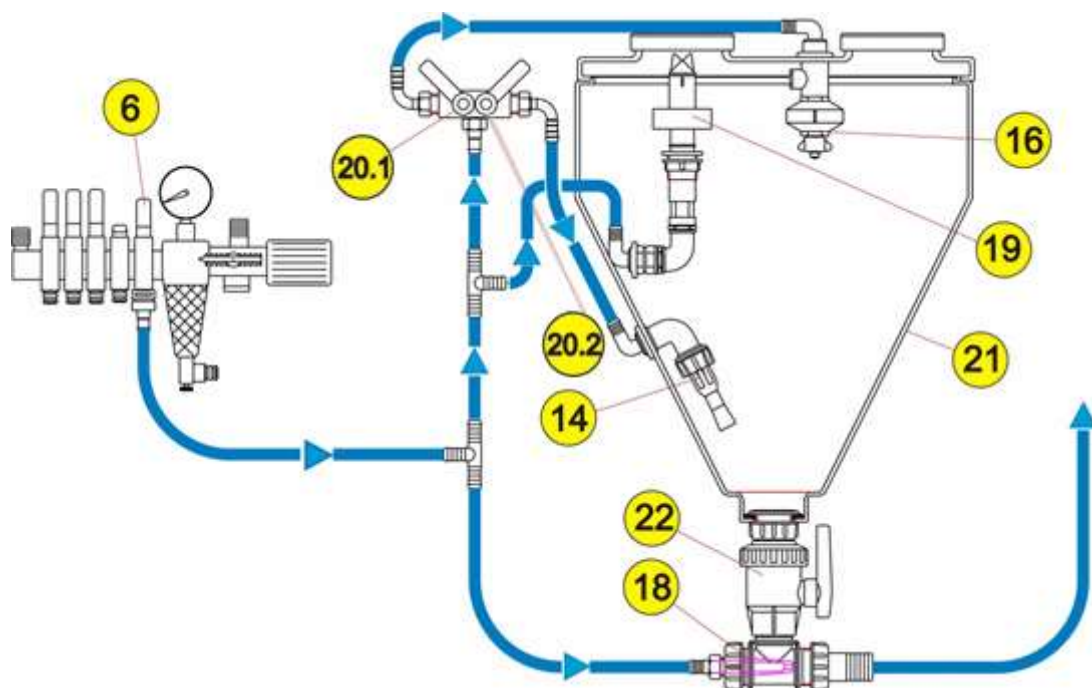

The filling reservoir is meant for mixing of the insecticide and preventing the insecticide to get in the main reservoir. It is usually mounted slightly lower on the side of the main reservoir, which assures the user an easier work when it comes to mixing insecticides. The filling reservoir consists of: a frame with reservoir (21), control valves (20), mounted on the frame, injector nozzle for mixing (14), rinsing nozzle of reservoir (16), valve with nozzle for rinsing packaging (19) and additional diversion valve on pressure regulator (6).

8.5.1 FUNCTIONING OF THE FILLING RESERVOIR:

Fill the main reservoir to approximately 1/3 with water, turn on the pump and open the main valve on flow regulator. Check if the control valves and release valve (22) on the filling container are closed.

Open the diversion valve (6) on pressure regulator and set working pressure to **min. 5 bar**. Fill approximately 1/3 of filling container with water by opening the lever of control valve (20.2), which supplies the injector mixing nozzle (14). You can control supply by opening the lever on control valve. Put or pour the foreseen amount of spray (according to spray manufacturer's instructions) in the filling container. Rinse the packaging with nozzle for packaging rinsing (19) by opening the cover and pushing the opening on packaging on rinsing nozzle with control valve closed (20.1.). Rinsing nozzle can also penetrate protective foil under packaging cover, so there is no contamination of the environment.

Open the control valve (20.2.) with injector mixing nozzle (14) and, when the level of mixed preparation is approximately 5 cm under the top of filling container, close the control valve (20.2.). Open the release valve (22), which, with the help of injector suction nozzle (18), enables suction of mixed preparation from filling container to main reservoir.

When the container is empty, leave the control valve (20.1.) for some time to wash out the filling container. Close the control valve (20.1.), wait that it pumps the content to main reservoir and then close the release valve (22). Close the diversion valve on pressure regulator (6) and close the main valve on flow regulator.



WARNING: Always use protective gloves while cleaning the filling reservoir!

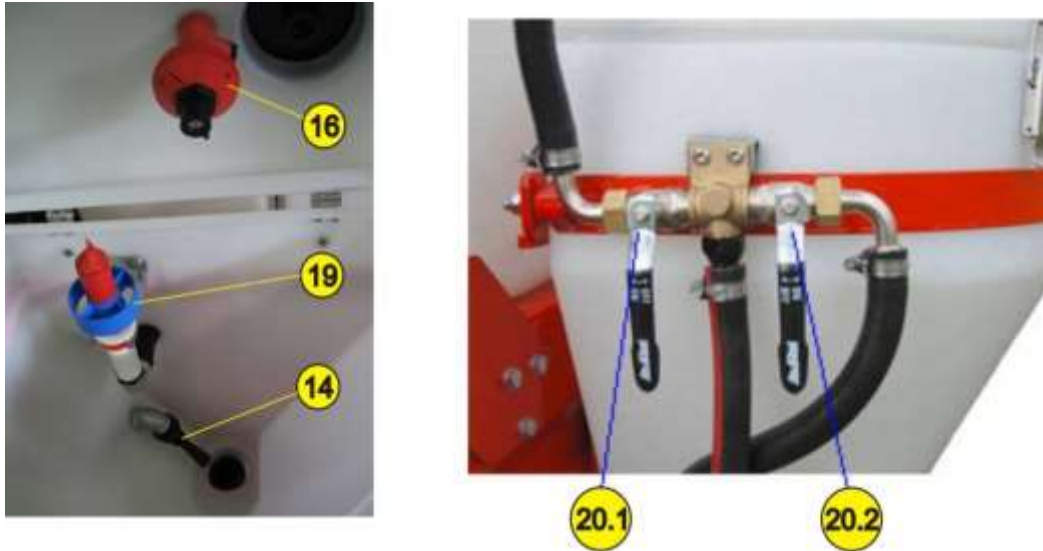

Figure 7.6

End cleaning of filling container interior is done after spraying, when cleaning the entire sprayer. Use rinsing nozzle of reservoir (16), which is activated by opening the diversion valve (6) on pressure regulator and control valve (20.1.) on filling container.



WARNING: Use protective equipment when cleaning!

8.6 MARKER

By using the marker, the foamy tracks, which are created by the marker, can be a great help, since they define the border of the previous spraying.

The foam is created with a proper mixing of air with a mixture of water and liquid detergent. The appliance makes white foamy points (diameter 10-20 cm) every 5-20 seconds (depending of the setting) and by this it creates a line, which marks the border of previously sprinkled surface.

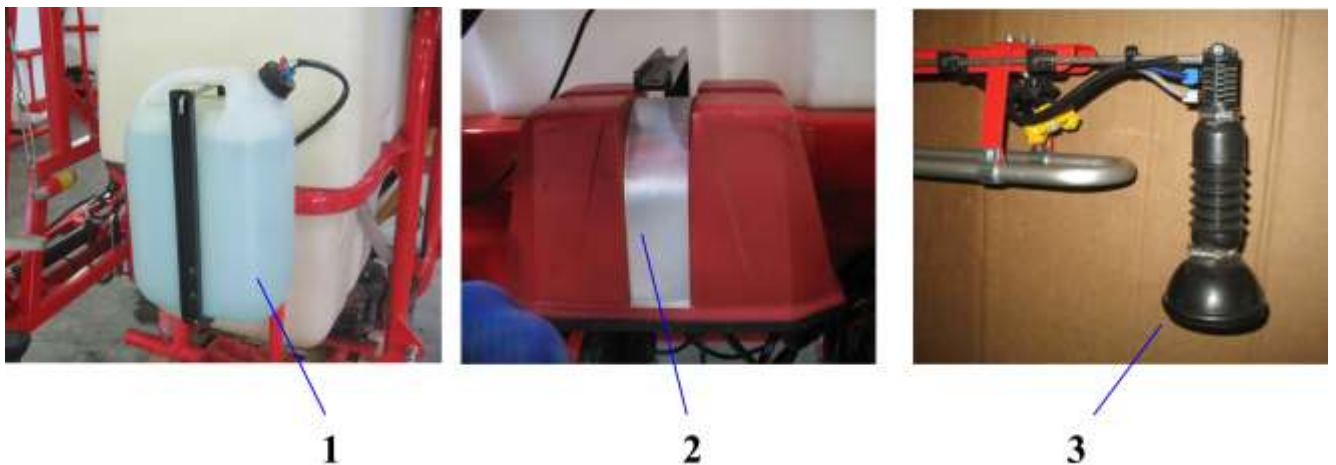

8.6.1 MOUNTING

Mount the reservoir for liquid detergent (1) to the side of the reservoir, the compressor block (2) to the rear side of the sprayer between the guides of the spraying garniture. The mixing nozzles (3) of the marker must be attached to the end of the spraying garniture and the control box in the cabin of the tractor. The connecting tubes must be guided along the spraying tubes of the spraying garniture and connected to the ties, but make sure the tubes will not be overstretched, as that could damage them. The tubes must allow you to normally handle the spraying garniture.

8.6.2 INSTRUCTIONS FOR USE

Since the marker is not a part of the sprayer's standard equipment, you can find detailed instructions for use in a separate booklet "MARKER-INSTRUCTIONAS FOR USE AND MAINTENANCE".

8.7 EXTERNAL FILLING OF THE RESERVOIR

For a simpler and more convenient filling of the main reservoir with water you will find a bayonet connector with a non-return valve on the upper side of the reservoir, through which the filling of the reservoir is safe and clean.

- In some cases the connection for external filling of the reservoir, is mounted on the top side of the main reservoir.



1. Non-return valve
2. Plug
3. Filling connector

8.7.1 FILLING MAIN RESERVOIR

⇒ FILLING (SUCTION) THROUGH PUMP

Major types of sprayers (600, 800, 1000, 1200 EN) have the connection for exterior filling of main reservoir integrated into the system of regulation valves under the main reservoir (23).

Also the sprayer is equipped with special bayonet connection (24), (for filling the additional reservoir), mounted directly on this reservoir.

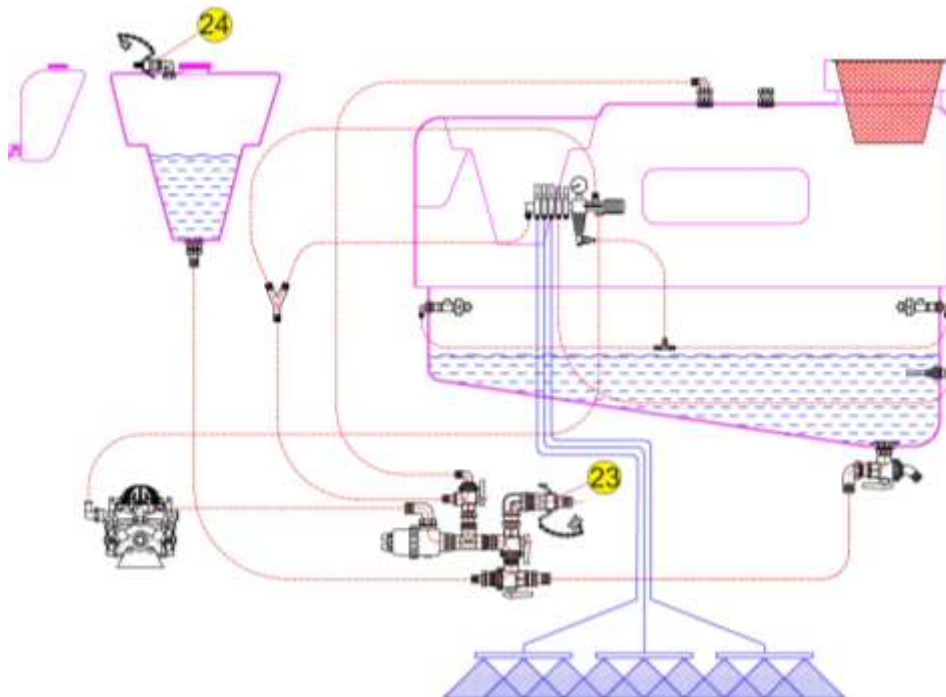

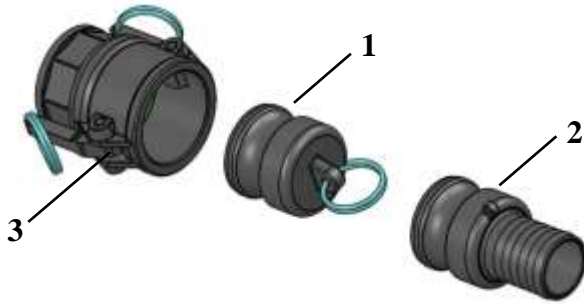

- 1. Stop valve
- 2. Fitting
- 3. Connection



PROCEDURE OF WATER SUCTION INTO MAIN RESERVOIR

Function of filling is done by suction of water through pump into the reservoir. Remove the stop valve (1), fit the suction hose to fitting (2) and secure it with hose clamp. Connect the fitting (2) with hose to connection (3) and secure it with side levers.

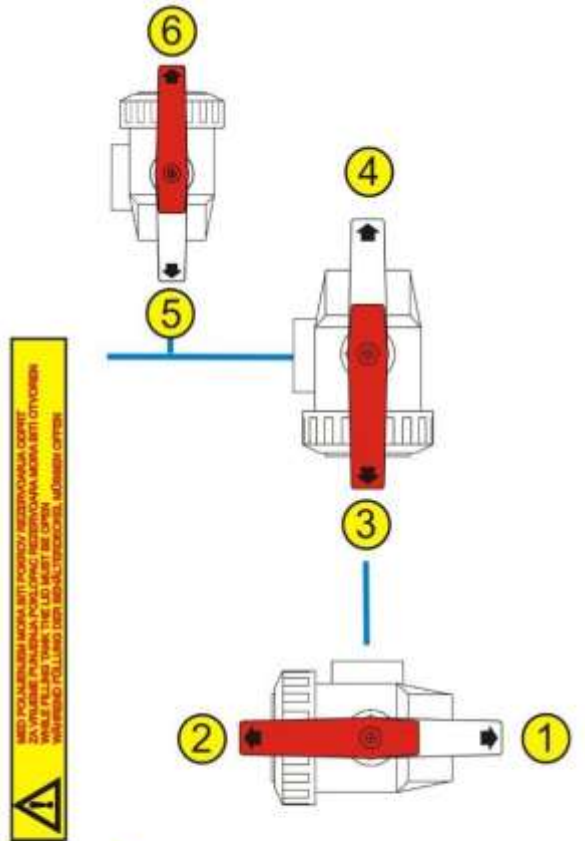

- Set the lever of selection valve to position 1.
- Open the lever of valve for exterior supply to position 4 (FILLING MAIN RESERVOIR).
- Set the lever of selection valve to position 6.
- After filling the reservoir, move the lever of valve for exterior supply back to position 3 and disconnect the fitting with hose.

- ① + ④ + ⑥ POLNJENJE GLAVNEGA REZERVOARJA-PUNJENJE GLAVNOG REZERVOARA
-MAIN TANK FILLING-HAUPTBEHALTER FÜLLUNG
- ① + ③ + ⑥ ŠKROPLJENJE-PRSKANJE
-SPRAYING-ABSPRITZEN
- ② + ③ + ⑤ DELNO ČIŠČENJE-DJELOMIČNO ČIŠČENJE
-PARTIAL CLEANING-TEILREINIGUNG
- ② + ③ + ⑥ POPOLNO ČIŠČENJE-POTPUNO ČIŠČENJE
-COMPLETE CLEANING-TOTALE REINIGUNG



WARNING: Gather water only from a pool or a water reservoir, never from a hydrant under pressure, because damage to the pump can occur!

⇒ FILLING THROUGH HYDRANT (ADDITIONAL EQUIPMENT)

The sprayer also be, optionally, equipped with system for exterior filling of main reservoir through a hydrant. Filling of main reservoir has additional protection of anti-reversing valve (4), which prevents flow of spray from the reservoir. Float valve mechanism, installed at the top on the cover, enables flow of air out of the reservoir, so it is not required to open the whole cover. Hose Ø 40 mm (1) is fitted to fitting (2) and secured with hose clamp. Fitting (2) with hose is connected to connection (3) and secured with side levers. Filling capacity is max. 250 l/min.

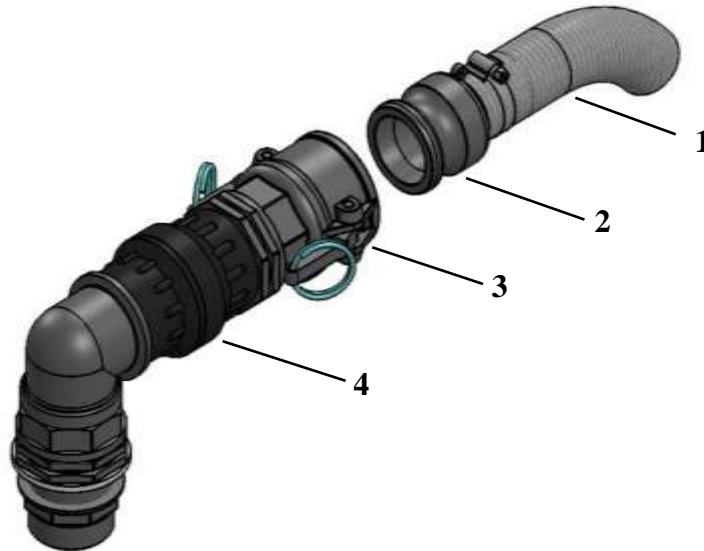

8.7.2 FILLING ADDITIONAL RESERVOIR FOR CLEAN WATER

Sprayers of this type are equipped with bayonet connection for filling of additional reservoir (24), installed directly on this reservoir. Before filling of additional reservoir, the cover on the top must be opened, so that air can escape.

When filling additional reservoir, insert fitting with hose Ø 19 mm in connection and secure it with side levers. After finished filling, disconnect it in reverse order.



8.8 CENTRAL SHUTTING OF THE PRESSURE LINE



This set is a part of the optional accessories for sprayers. With the help of electric motor valve through which the flow from the pump to the flow regulator and to the control panel is guided, the operator is able to remotely control the flow of pesticide to the nozzles from the tractor cabin.

The system allows for a rapid start and stop of the flow of pesticide from the pump to the flow regulator and indirectly to the nozzles without any other interventions into the flow regulator settings. It is especially useful when turning at the end of the field during spraying, when crossing between two spraying surfaces, as you don't have to turn off the cardan drive. Besides, the control panel inside the tractor cabin enables you to operate the machine with a closed cabin.

8.9 LIGHTS SIGNALLING

Lights are mounted to the rear side of the spraying garniture. They are equipped with luminous boards (RED-WHITE), rear lights with a reflective triangle and two white reflectors, which are mounted to the front side of the garniture. Connecting cable with a plug is guided to the tractor cabin. Elements of lights signalling are shown in the pictures below.



9 FLOW REGULATOR

9.1 THE FLOW REGULATOR PR-3

The flow regulator PR-3 is meant for precise regulation of the working pressure from 0-10 bars. The basic version of the flow regulator PR-3C consists of a regulation valve, a central valve with vacuum anti-dripping system and direction control valves.

The improved version PR-3B has direction-control-regulating valves mounted instead of direction control valves, which enables you to precisely set the operating pressure in individual sections of the spraying garniture. The regulator is also equipped with a self-cleaning pressure filter.

9.1.1 REGULATOR MARKING

The basic marking PR-3C and PR-3B can be given an additional letter F which stands for the self-cleaning pressure filter. The number of direction-control-regulating valves and direction control valves is marked with a numeric code (the first number marks direction-control-regulating valves and the second marks direction control valves).

For example:

The marking PR-3BF/5+1 stands for the regulator PR-3B with the self-cleaning pressure filter, five direction-control-regulating valves and one direction control valve.

9.1.2 REGULATION AND CENTRAL VALVE

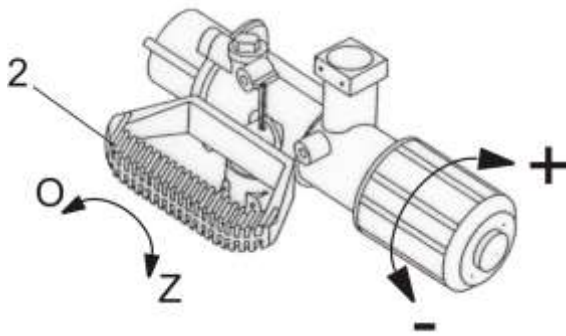

The regulation valve is meant for precise working pressure regulation from 0-10 bars. By turning the regulation nut to the right you can increase the working pressure; by turning it to the left you can lower the working pressure. The central valve can be closed and opened by turning the lever 2. When the lever points to the left (position O) the flow to the direction control valves is opened, by turning it to the right (position Z), the flow to the direction control valves is closed. By turning the lever to the right, the return line and the vacuum anti-dripping system are activated.

9.1.3 SELF-CLEANING PRESSURE FILTER

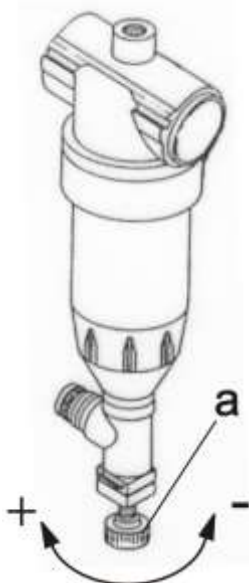

The self-cleaning pressure filter additionally cleans the insecticide before this is sprayed through the nozzles. Small parts that get caught in the filter insert (density M 50) are sent back to the reservoir through the valve mounted at the bottom of the filter (a) when cleaning the filter insert. During operation the filter must remain closed.

However, when using pumps with larger flows, you can disburden the regulator by opening the valve (a) on the filter bottom, but you must be careful as it could happen that you won't be able to achieve the required spraying pressure. In such an event you must close the valve or at least turn it down to such an extent, that pressure in the sistem will rise to the required limit.

Periodical cleaning of the filter is performed by opening the valve (a), so a part of the flow is redirected back to the reservoir.

A thorough cleaning of the filter must be performed after spraying. You can find the precisely described procedure in a separate chapter.



WARNING: Since an opened valve can cause huge pressure drops when using less powerful pumps or nozzles with a higher flow, it is recommended to close the valve in such a case.

9.1.4 DIRECTION-CONTROL-REGULATING VALVE "B"

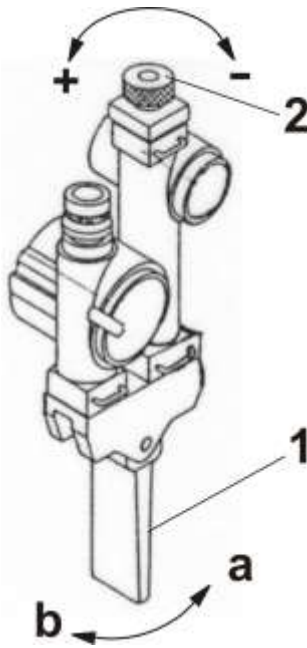

Direction-control-regulating valves assure a constant working pressure regardless of how many direction control valves or how many segments of the spraying garniture are opened. By switching the valve lever (1) to the position (a) you open the insecticide flow to the nozzles. By turning the lever to the position (b), you close the insecticide flow to the nozzles but open the return valve. Correctly adjusted return valve returns the same amount of insecticide to the reservoir as the nozzles would use when the lever is in position a.

The return valve can be adjusted with the help of the nut (2).
The regulator PR-3B includes these valves.

9.1.5 DIRECTION CONTROL VALVE "C"

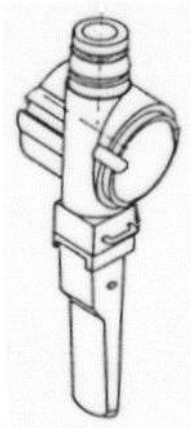

Direction control valves are used as valves for closing and opening of mixing lines and for closing and opening of individual sectors of sprayer garnitures with smaller working widths.

They can also be used as valves to feed the assemblies that are parts of sprayers' optional equipment.

All types of PR3 flow regulators are equipped with these valves.

9.1.6 SETTING OF THE WORKING REGULATOR

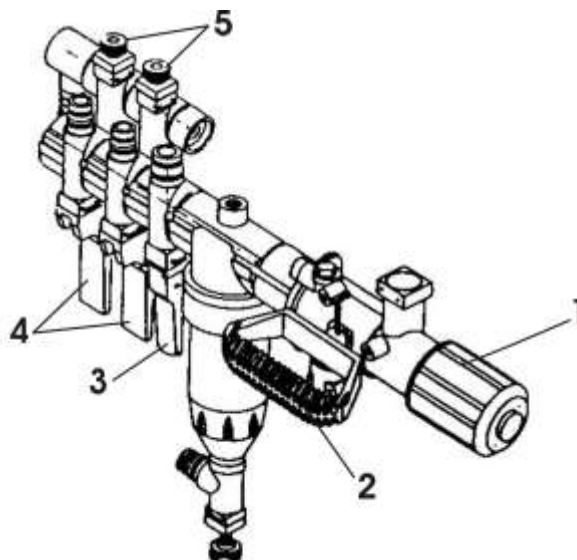

1. Always perform the setting with clean water!
2. Calculate the required working speed concerning the insecticide consumption per hectare and the flow through nozzles;
3. Adjust the tractor's rpm in accordance to the calculated working speed;
4. Open all of the direction-control-regulating valves (4) and the mixing valve (3) (picture 10.5);
5. Open the central valve;
6. Adjust the working pressure;
7. Adjust the return valve on direction-control-regulating valves:
 - Close the first direction-control-regulating valve. The working pressure will change according to the manometer.
 - Level the working pressure by turning the regulation nut on the first valve.
 - Level all of the other direction-control-regulating valves in the same way
8. The return valves will need adjustment when changing the nozzles.

9.2 ELECTRONIC REGULATION OF PR3 EC (OPTIONAL)

Flow regulator PR-3EC is used for electronic regulation of spraying parameters on all types, both carried and driven sprayers, for operating pressure from 0 to a maximum of 12 bar. The control of all regulator's functions is accomplished using AG-TRONIKA, through which all electric motors in the individual valves and sprayer sections are controlled.

The system is a part of optional equipment of the sprayer and its operating manual with a catalog of spare parts is issued in a separate booklet, which is attached to all machines that are equipped with this system.

9.3 MAINTENANCE OF THE REGULATOR

After every single spraying the regulator needs to be washed with clean water. The rests of the insecticides can gnaw through sealings and shorten the durability of the regulator. The easiest way of cleaning the filter is to open the valve on the filter and close all of the direction control valves and let the water flow through the filter. Clean the filter insert by hand from time to time and replace it if it is worn or damaged. To do this, turn the lower part of the filter (E 14022/1) in counter clockwise direction, pull out the filter insert E (14021) and clean the inside of it with a brush and flowing water. Before reassembling the filter also clean the seal and its place and grease the seal. This applies to all junctions where round sealings are used.

Oil all of the moving parts and threads of the regulator every 40 working hours. Thoroughly clean and grease the "0" sealings before connecting the connecting parts together. When assembling the parts, slightly turn the attachment in order not to damage the seal.

Empty the reservoir during winter.



WARNING: Use protective gloves while cleaning the regulator!

10 PUMPS

Pumps are a vital element of spraying appliances. The reliability and a long durability of the pump also depend on how you treat the pump and whether you use and maintain it correctly.

IMPORTANT: The standard version of all pumps is equipped with membranes which are made of NBR rubber. Therefore it is the user's duty to use only chemical agents for spraying which do not harm this kind of material. On the opposite, the manufacturer can not be held responsible for any kind of damage that could occur.

10.1 CHECK BEFORE USING THE APPLIANCE

When the pump is not operating check the oil quantity in the housing of the pump. Also check the oil level every single time before filling the reservoir. The level must be within the limits which are marked on the oil lid or in the oil pot (depends on the version of the pump). If the oil level is too low add some oil whereas be careful not to exceed the maximum allowed level.

The air pressure in the air chamber depends on the working pressure which can be found in the diagram on the left. The air pressure in the air chamber must never be higher than the working pressure of the pump.

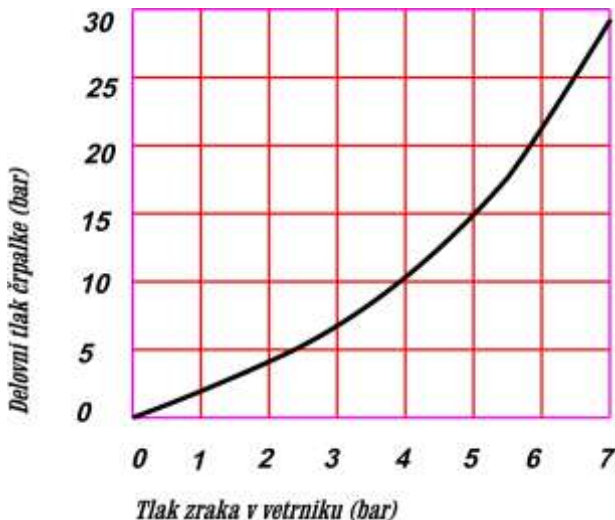

Make sure that the valves ensure free flow of liquid from the reservoir to the pump. Also check the porousness of the suction filter insert and the suction hose (make sure that the hose is not folded).

10.2 USE

Before turning on the pump make sure that the main valve is switched to position “Z” (see chapter “Regulation and central valves”).

Never turn on the pump's drive when the setting on the regulator enables full stressing of the pump.

Turn on the pump and let it run for approximately one minute under minimum pressure in order to aerate the pump and the inlet and the outlet pipes. After one minute the pump is ready for operation. Be careful not to exceed the maximum allowed pressure and the maximum allowed rpm of 540. On the opposite, the manufacturer can not be held responsible for any kind of damage that could occur.

10.3 AFTER USE

Some chemical agents can shorten the durability of some vital parts of the pump such as rubber membranes and/or other rubber sealings. Therefore a thorough washing of the pump after every single spraying is recommended. To do this, you will need to pump some clean water through the pump. Let the pump operate at working pressure for several minutes. Lower the pressure and let the pump operate for approximately one minute to blow out the rest of the liquid.

During winter, leave all of the water out of the pump and/or protect the pump against freezing (see chapter “Maintenance and storage after use”).

10.4 PISTON MEMBRANE PUMPS BM 65/30, BM 105/20 AND BM 150/20

Type BM 65/30, BM 105/20 and BM 150/20 pumps are low-pressure piston membrane pumps with 2, 3 or 4 pistons, made of materials that have been tested by the factory. The pumps are suitable for pumping of insecticides or liquid fertilizers which are used in farming.

10.4.1 TECHNICAL DATA

PUMP TYPE	BM 65/30	BM 105/20	BM 150/20
FLOW QUANTITY (l/min)	68	93	149
WORKING PRESSURE max. (bar)	25	20	20
RPM max. (n/min)	540	540	540
REQUIRED POWER (kW)	3,2	3,5	5,5
NUMBER OF PRESSURE MEMBRANES (pcs.)	2	3	4
WEIGHT (kg)	13	12,5	24
OIL	HYPOID OIL SAE 90	ENGINE OIL SAE 15W30	ENGINE OIL SAE 15W30

OPERATION	INTERVAL CHECKS			
	Every 8 h	Every 50 h	Every 300 h	Once per season
Oil level check	X			
Air chamber check		X		
Check of the pump attachment to the frame		X		
Membrane check and replacement if necessary			X	
Oil change			X	
Valve check			X	
Check of screwed joints				X

10.4.2 OIL CHANGE

Change the oil for the first time after the first 10-20 working hours and after that every 300 working hours. Also check the membranes when changing the oil. Replace damaged or worn membranes with new ones. It is recommended to change the membranes every 300 working hours.

Membranes check for BM 65/30: To check the membranes, unscrew the bolts (019.07.031) on the lower fork, release the suction collector (016.20.008) and the air chamber (018.30.004). Then unscrew the bolts (019.31.305) of the pump chamber (017.03.002) and remove the chambers. Carefully inspect the upper and lower side of the membranes. Release the oil at the same time.

Membranes check for BM 105/20: To check the membranes, first of all unscrew the bolts (540015) on the covers of the pump 017.41.007 and release the suction and pressure collector. After that, unscrew the bolts 019.31.317 on the covers 017.41.007 and remove the chambers. Carefully inspect the upper and lower side of the membranes. Release the oil at the same time.

Membranes check for BM 150/20: To check the membranes, first of all unscrew the bolts 540015 on the pump covers 017.41.007 and release the suction and pressure collector. After that, unscrew the bolts 019.31.317 on the covers 017.41.007 and remove the chambers. Carefully inspect the upper and lower side of the membranes. Release the oil at the same time.



WARNING: Make sure that the worn oil is poured into appropriate tanks! Do not discard worn oil in nature!

It is recommended to clean the inside of the pump and its vital parts with diesel oil before reassembling the pump. Assemble the pump in the opposite direction. Be careful to correctly insert the valves (see the catalogue). After that, pour fresh oil into the pump. For pumps type BM 65/30, oil needs to be poured in through the hole of the oil lid 019.01.101. For pumps type BM 105/20 and BM 150/20, oil needs to be poured in through the oil pot 017.01.142 or 017.01.146.

While pouring oil into the pump, turn the shaft of the pump several times by hand in order to press out any excess air which is caught between the piston and the membrane. Pay attention to the oil level.

Turn on the pump for few minutes at minimum pressure. Pay attention to the functioning of the pump and add some oil if needed.

What to do in case of a damaged membrane: If the oil in the oil pot (BM 105 or BM 150) whitens or the oil lid falls off (019.01.101) for the pump BM 65, immediately stop operating the machine and replace the damaged membranes. On the opposite, the pump can be heavily damaged. It is also possible to recognise a damaged membrane by means of the manometer, since its pressure pointer does not come to a halt.

Maintenance: After every single use, it is recommended to wash out the inside of the pump as well as other parts of the sprayer with clean water.

11 SPRAYING GARNITURES

- The spraying garnitures 10MRX, 12MRX and 15MRX are “manual” garnitures (manual opening and closing), equipped with a trapezium mechanism for adjusting of the garniture to the terrain, a side-oscillation stabilizer, a safety mechanism and bayonet nozzles with membrane anti-dripping system.
- The spraying garnitures 12MY, 12MY-H and 15MY-E are hydraulic garnitures (the opening and closing from the transportation position into working position and vice-versa is performed with the help of hydraulic cylinders), equipped with a trapezium mechanism for adjusting of the garniture to the terrain, a safety mechanism and full nozzle protection as well as bayonet nozzles with membrane anti-dripping system.

All spraying garnitures are factory equipped with flattened jet fissure nozzles. Distance between the nozzles is 0.5 meters.

11.1 TRAPEZIUM MECHANISM

The four-point trapezium system (picture) enables the spraying garniture to adapt to the terrain ($\pm 10^\circ$) and functions normally to a slope of 5° . If the trapezium it is set correctly and if the sliding surfaces (sliding plates) are well greased, the trapezium functions without any problems. Pay special attention to the setting of sliding plates 019.20.009. The sliding plates must be set in such a way that the unblocked frame, pushed to one uttermost end, gets back into horizontal position by its self. The sliding plates must be tightly attached to the frame. There should be no free space between the sliding plates (picture).

The function of the blockade is to limit the movement of the trapezium (the garniture adapts to sprayer's tilt).

Situations in which the blockade must be blocked:

- transportation position;
- in the case one part of the garniture is closed (one side);
- when driving along a hill with a slope higher than 7° .

In the case the slope of the hill is less than 7° de-block the garniture (picture) and adjust the spanners (until the garniture is even with the terrain) – the spraying garniture will follow the adjusted slope.

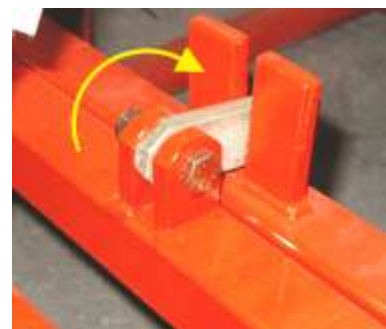

11.2 SPRAYING GARNITURES 10MRX, 12MRX AND 15MRX

The spraying garnitures series MRX are made of a light pipe construction. The opening and closing of the garniture is performed manually.

11.2.1 OPENING AND CLOSING OF THE SPRAYING GARNITURES 10MRX, 12MRX AND 15MRX

1. Make sure that there is enough space around the machine before you open the spraying garniture.
2. Check whether the blockade is correctly positioned (the tongue must be in the notch).

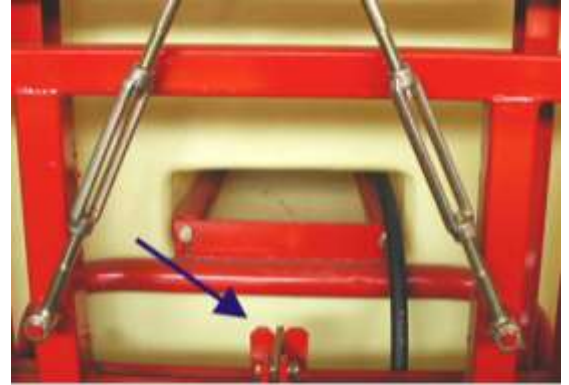

3. While the garniture is in transportation position, its extensions are secured by small handles. First pull out the safety pin, then turn the lever and lower both left and right handle of the spraying garniture.

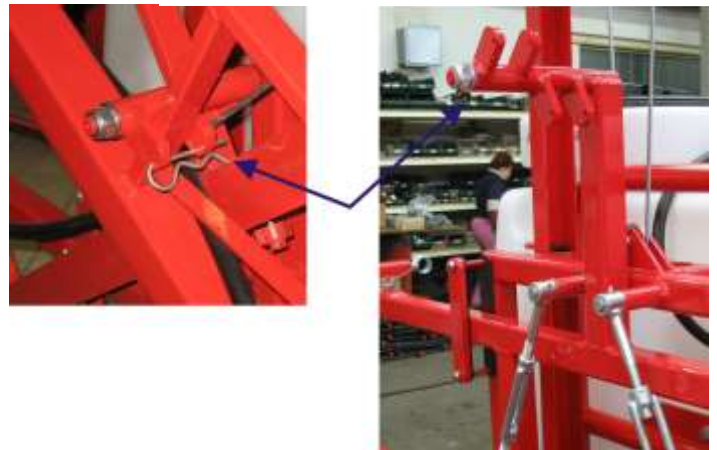

4. First open the arm 1. Lift arms 2 and 3 together and turn them around the centre of rotation of the first arm.
5. Repeat the opening procedure on the left side of the garniture.

6. Tighten the working position by means of the clamping jig. The position of the clamping jig must be the same as shown in the picture. The stiffness of the garniture is assured by the wire rope which makes the garniture resistant against oscillating towards the driving direction.



Pay attention to the strength of the wire rope since the arms of the garniture will swing forwards and backwards if the wire rope is not tightened properly. This can affect the quality of spraying and also damage some of the spraying garniture's vital parts.

7. You can adjust the tension by turning the tension bolt (picture above). If the wire rope is well strained, the spraying arms can bend a little bit in the driving direction. This bending should not exceed 10 cm from the end of the spraying garniture. Turn the adjustment bolt if you want the sprayer garniture to be vertically straight.

8. After you have opened the spraying garniture, the height, de-blocking and the tilt of the garniture need to be adjusted. You will find further instructions in the following sections.
9. To close the spraying garniture again, follow the above written instruction in the opposite direction.

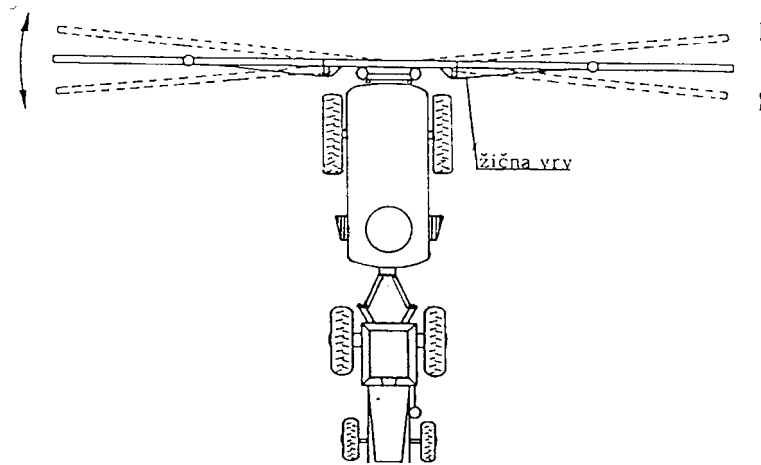

The rear arm is protected with a safety hinge (picture on the left) which makes the arm to move when hitting an obstacle. When you pass the obstacle, the arm will move back to its primary position (picture on the right).

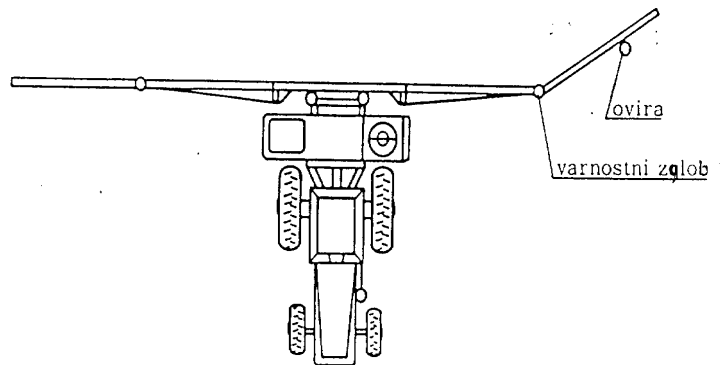

11.2.2 LIFTING OF THE GARNITURE TYPE MRX

The standard equipment of the MRX sprayers includes a manual lift, which is tightly attached to the frame of the sprayer. The garniture is fixed through the lift and a spring, which absorbs vertical oscillation. The smooth vertical nozzle-height-adjustment is performed through a vertical guidance with four wheels.



1. Manual lift
2. Spring
3. Leading wheel

11.3 SPRAYING GARNITURES 12MY, 12MY-H, 15MY AND 15MY-E

These types of spraying garnitures are equipped with hydraulic cylinders, which automatically open and close the spraying garniture. The standard equipment of all MY type sprayers includes the trapezium mechanism which automatically adapts spraying garnitures to the terrain configuration. Garnitures 12MY-H and 15MY-E are also equipped with a hydraulic leveling system.

There are some differences in control system of individual types of spraying garnitures 12MY, 12MY-H and 15MY-E, so each type is separately described below.

11.3.1 SPRAYING GARNITURE 12MY

Since there could be some air caught in the pistons, the following must be done before using the spraying garniture for the first time:

- Remove the safety elements from the spraying garniture (remove the transportation chain and open the clip).
- Open the arms of the garniture by hand. This kind of work should be performed by two people (each individual on one side of the spraying garniture), since the pressure, which can accumulate in one of the cylinders, can be carried over to the other cylinder and open the second arm and damage the spraying garniture.
- Connect the hydraulic connectors to the tractor (picture below on the right). One standard hydraulic connector is required to open hydraulic garniture.
- Lift the garniture for approximately 1 meter of the ground and block the blockade (see chapter 11.1).
- Close the spraying garniture by means of the hydraulic valve in the tractor.



In this way, the garniture is free of air and ready to be used.

⇒ OPENING AND CLOSING OF THE SPRAYING GARNITURE FROM THE TRANSPORTATION POSITION IN THE WORKING POSITION AND VICE-VERSA

- Remove the safety elements from the spraying garniture (remove the transportation chain and open the clip, picture 12.15 and 12.16).
- Check the connection of the hydraulic connectors on the tractor (picture 12.14).
- Make sure that the blockade of the trapezium is in blocking position (picture 12.22).
- Open the spraying garniture by means of the hydraulic valve in the tractor. Both left and right arm will open simultaneously.
- Before the opening or closing process finishes, close the hydraulic valve a bit in order to slow down the movement of the spraying garniture.
- Check whether the height of the spraying garniture is appropriate (working height) and adjust it if necessary.
- In the case your sprayer is equipped with a hydraulic control valve for controlling of the hydraulic cylinders for hydraulic leveling, hydraulic lifting or individual opening (additional equipment) the process remains the same whereas you need to be careful to retain the correct order of controlling the individual cylinders. In such a case it is recommended to slightly lift the spraying garniture, level it if necessary and start the opening process.

To close the spraying garniture again, follow the above written instruction in the opposite direction.

Arms 1 and 2 of the spraying garniture 12MY open simultaneously by means of a wire rope, so you will need to check the tension of the rope from time to time. This can be easily checked on the tension bolt (018.40.021) which needs to be pulled out of the bolt (018.01.250) for approximately 2-4 cm when the spraying garniture is in working position (see picture).



WARNING: While opening the spraying garniture, make sure that there are no people within its working area!

The spraying garniture can be opened only if the tractor is not moving; on the opposite, the spraying garniture or surrounding objects can get damaged.

11.3.2 SPRAYING GARNITURE 12MY-H

Construction of the spraying garniture 12MY-H is, with certain improvements, similar to the constructure of the above described spraying garniture 12MY, the only change being the improved safety mechanism to protect against the uncontrolled opening during transport.

Changing the hydraulic settings of the spraying garniture is done with the help of electromagnetic hydraulic valves and by using a control panel with two switches and a graphic display of all useful functions of hydraulic controls, which needs to be installed in the tractor cabin.

To connect the hydraulics, your tractor must be equipped with two pairs of standard hydraulic connectors.

To avoid incorrect connection of hydraulic hoses of the spraying garniture with the tractors' hydraulics and with it the instable operation of the spraying garniture, the pipes are specially marked with labels to assist with the correct connection (red P-pressure line, blue T-return line).



When connecting hydraulic hoses, the tractors' hydraulic valves must not be under pressure!



When the spraying garniture is in transportation position, it is secured against uncontrolled opening with a mechanical latch and before you can open it to a working position, you first have to correctly complete a sequence of required tasks otherwise the opening system will not be functioning.

Because of the risk to cause mechanical damage to the spraying garniture when failing to correctly complete a sequence of required tasks, the entire hydraulic system is protected with a non-return valve which, until activated, only allows the operation of the lifting hydraulic cylinder of the spraying garniture.

⇒ **OPENING AND CLOSING OF THE SPRAYING GARNITURE FROM THE TRANSPORTATION POSITION IN THE WORKING POSITION AND VICE-VERSA**

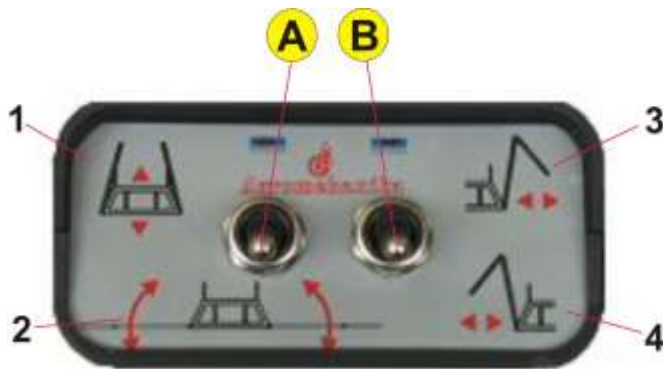

- A1 - raise/lower
- A2 - leveling
- B3 – opening the right-hand side
- B4 - opening the left-hand side

THE PROCEDURE FOR OPENING/CLOSING:

- Check the joints of hydraulic connections on the tractor;
- Check the joints of all electrical connections (power supply, solenoid hydraulic valves);
- Check to see if the trapezoid blocade is in a blocked position;
- Make sure the switch A on the control panel (picture above) is in position 1 then use the hydraulic valve inside the tractor and start lifting the spraying garniture;



- During lifting the non-return valve with installed wheel travels along the rail (picture on the right). This is designed in such a way, that at a certain height, when the closing tooth doesn't lie within the transport protection anymore (picture on the left), a flow of oil is released through the non-return valve to the valves that are controlling the opening and closing.
- Use the lever of the second hydraulic valve of the tractor to start opening the right- (position of the switch on the control panel B3) or left-hand (B4) side.
- Towards the end of opening/closing process slightly reduce the flow through hydraulic valve to reduce the speed of opening/closing of the spraying garniture.
- Lower the spraying garniture to the working height and if necessary adjust its height with a cylinder for hydraulic leveling.

To close the spraying garniture again, follow the above written instructions in the reverse order.

11.3.3 SPRAYING GARNITURE 15 MY –E

The protection system against uncontrolled opening during transport is constructed in the same way as in the spraying garniture 12MY-H and is described in the previous chapter.

Similarly, the entire hydraulic system is protected with a non-return valve which until activated, only allows the operation of the lifting hydraulic cylinder of the spraying garniture.

Because of all these similarities, the entire hydraulic operation of the spraying garniture is very similar, the only difference is in the use of equipment, which is described below.



Hydraulic connecting clamps (male part)

A block of elektromagnetic hydraulic valves

For a connection with the tractor's hydraulics, you will need one pair of hydraulic connecting clamps, which are, to avoid them being used incorrectly, marked as follows:

- P-red, power
- T-blue, return line

1. COMPONENTS USED FOR OPERATING THE SPRAYING GARNITURE

⇒ Connection scheme:

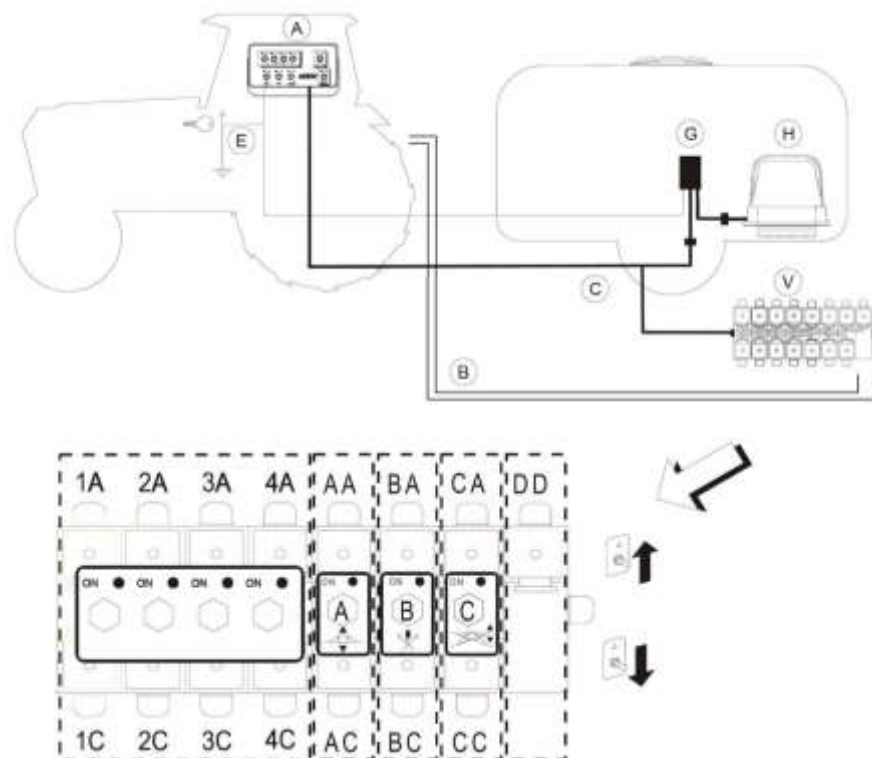

⇒ The command panel is an integral part of the spraying garniture 15MY-E hydraulics operation and has to be installed at the appropriate place inside the tractors cabin. It includes the graphic display of all operating functions that can be executed with hydraulics.



⇒ The meaning of signs on the connection scheme:

Sign	Description	Remark
A	Command panel for operating the garniture	
B	Connecting hydraulic pipes with clutches for connection to a tractor	
C	Connection cable between a control panel and electromagnetic hydraulic valves	
D	The extension of a connecting cable	
E	Power cord + plug for powering	
G	Interface for connecting the marker	
H	Marker	
V	Hydraulic block with electromagnetic valves	
1A-1C, 2A-2C, 3A-3C, 4A-4C, 5A-5C, 6A-6C,	Electromagnetic hydraulic valves for opening individual sections (signs on the connection cable)	
AA-AC,	Electromagnetic hydraulic valves for lifting the garniture	
BA-BC,	Electromagnetic hydraulic valves to block the garniture	
CA-CC,	Electromagnetic hydraulic valves to level the garniture	
DD	Electromagnetic hydraulic operating valve	





⇒ Technical and working characteristics

Description	Value
Supply voltage	12V DC
Working area	0°C - 70°C
Fuse	10 A
Pressure of the safety valve	120 bar

⇒ Electrical connection to the tractor

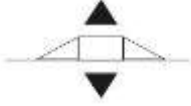
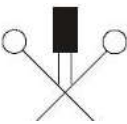
Command panel is connected to tractor's source of direct electric current of 12 V DC and a maximum current of 10A with a power cord (E). Connect the connection cable of the electromagnetic hydraulic valves (C) to the command panel. If necessary (if the cable is too short), use an extension (D).

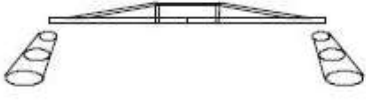
⇒ Description of functions of the control panel

Function	Description	
 Arms movement 1-2-3-4-5-6	opening	↑
	closing	↓
 Height setting	up	↑
	down	↓
 Blockage operation	blocked	↑
	floating	↓
 Leveling operation	Leveling- lift of the right-hand side	↑
	Leveling- lift of the left-hand side	↓
 Marker	right-hand side-switch on	→
	switch off	
	left-hand side –switch on	←
 Main switch	turn the control panel on	↑
	turn the control panel off	↓

11.4 HYDRAULIC LEVELLING (ADDITIONAL EQUIPMENT)

The hydraulic leveling makes your work easier since you can adjust the length of the spanner (in this case the hydraulic cylinder) and the tilt of the trapezium of the spraying garniture by means of a hydraulic valve during spraying.

By doing this, you can significantly influence the linear insecticide distribution on the surface and consequently improve the quality of spraying. We recommend using this system if the working place is uneven or inclined and therefore requires many adjustments of the spanners. To use the hydraulic leveling system, the tractor must be equipped with a double standard hydraulic connection.



11.5 SPRAYING TUBES

Shapes and designs of the spraying tubes (PE), used in spraying garnitures types MRX and MY, are shown in the picture below. They are marked with the numeric code.

Example: spraying tube 2/2

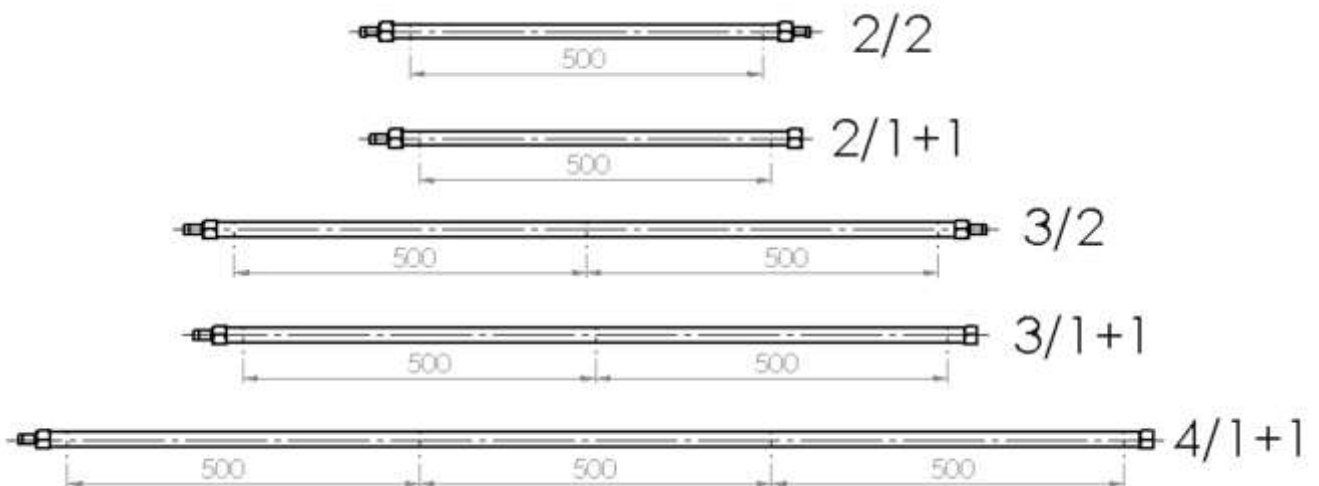

11.6 NOZZLE HOLDERS

11.6.1 MEMBRANIC NOZZLE HOLDER

Single nozzle holders with nozzle mouthpieces inside them are a part of standard equipment of spraying garnitures. A nut (1), with a different shape for different types of nozzles, is used to attach the nozzle mouthpieces. Nozzle components are listed in the catalog of spare parts.

An integral part of the holder is also a membranic anti-dripping valve (2), which prevents dripping of solution form the nozzles during the suspension of spraying.

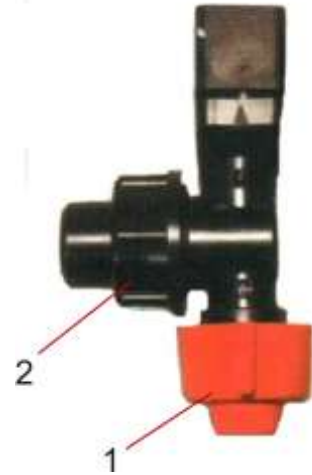

11.6.2 TRI-GET NOZZLE HOLDER (ADDITIONAL EQUIPMENT)

As additional equipment you can mount the TRI-GET nozzle holders on the spraying garnitures. Each of these nozzle holders contains three different nozzle mouthpieces. They are attached with nozzle nuts (1), with different shapes and colours for different types of nozzles. By rotating the lower part of the holder you can easily switch between nozzle mouthpieces and choose the one that is appropriate for a given spraying operation. These holders are also equipped with a membranic anti-dripping valve (2), which prevents uncontrolled dripping from the nozzles. Nozzle holder components are listed in the catalog of spare parts.

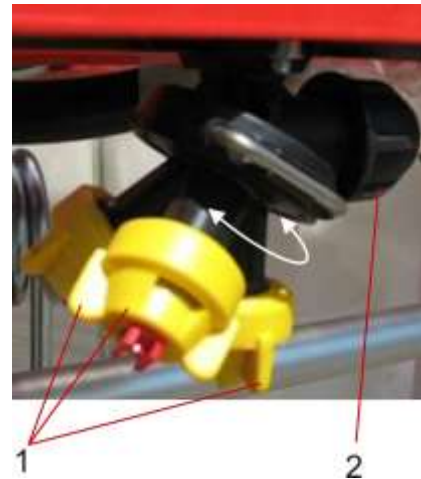

11.7 MAINTENANCE OF SPRAYING GARNITURES

Periodically check screws and bolts, pins and especially safety pins, their tightness and their condition. Tighten or replace them if necessary.

The garnitures are equipped with some adjusting bolts, which need to be adjusted from time to time. To do this, open the arms of the garniture in the working position and adjust the arms of the garniture which must be parallel to the shoulder of the spraying garniture.



IMPORTANT: make sure that you have attached and tightened the nuts of the adjustment bolts after adjusting the spraying garniture.

GREASING:

Grease all moving parts of your spraying garniture after every 40 working hours. The spanners on the trapezium and the axes of the hydraulic garnitures are equipped with greasers type C6 (picture 12.1). In the case your spraying garniture is being cleaned by a high-pressure cleaning appliance, it is recommended to grease all parts after every single cleaning.

After washing the spraying garniture, check if any of the hoses or joints leaks and check the condition of the flexible hoses. Repair broken hoses or loose joints at the right time, since that kind of errors can cost you a lot of time during spraying.

Some insecticides contain solvents which affect the paint. Clean the corrosion of colourless parts of the spraying garniture and apply some new paint.

11.8 HOW TO CLEAN THE SPRAYER

After every single use of the sprayer, the appliance must be thoroughly cleaned. The best way to use any excess insecticide is to dilute it with water and spray it on the same surface again. The concentration should be at least 10% (10 units of water per one unit of insecticide), the spraying speed slightly faster and the spraying pressure slightly lower (1.5 bar, depending on the nozzle). While doing this, use the additional reservoir for washing. The procedure is described in the chapter “COMPLETE CLEANING OF THE SPRAYER”. After that, thoroughly clean the sprayer on the inside and the outside and also clean all tools which you have used for spraying (including the tractor). Use only detergents that are recommended by the manufacturer of protection agents! If there are instructions for cleaning of the appliance after using it attached to the instructions for using the insecticide, follow them.

In accordance with the local legislation on washing of the pesticides into the earth, agree on cleaning of your sprayer with your advisory service.

The ablution of pesticides (cleaning of the sprayer) must not be performed on swampy ground or in the near of streams, water dams, dykes or water fountains, etc.

If there is still some insecticide inside the sprayer and if you had to stop working unexpectedly for some time it is recommended to clean the pump, the regulator and the spraying lining with clean water (see chapter PARTIAL CLEANING OF THE SPRAYER).

In the case you had to stop working unexpectedly but did not clean the sprayer yet, **you have to assure that other people or animals can not reach the sprayer.**



REMEMBER:

- Only a clean sprayer appliance is a safe appliance.
- A clean sprayer appliance is ready to be used.
- A clean sprayer appliance can not get damaged by chemical agents or chemical solvents.

When cleaning the sprayer use appropriate protection clothes. Choose appropriate detergents for cleaning and, if necessary, appropriate insecticide neutralising agents (see recommendations of the insecticide manufacturer).

In the case you are using a mixture of detergent and water for cleaning, pour it into the main reservoir, close the main valve on the pressure regulator, turn on the pump, open the direction control valve for mixing, open the self-cleaning filter valve and only after few minutes open the direction control valves of the nozzles. Be careful when choosing the place for releasing of the cleaning agent. Some detergents become active only after few minutes, so the cleaning process can be slightly longer (see instructions of the manufacturer).



WARNING: Be careful while handling detergents; follow the instructions of the manufacturer!

After cleaning the sprayer with a detergent, fill the tank to at least 1/5 with clean water and repeat the cleaning process. Make sure that you have cleaned all elements that have come in contact with the insecticide or the detergent. Make sure that you have precisely cleaned all filters. Be careful not to damage the fabric on the filter insert while cleaning filters. If the filter insert is damaged, replace it with a new one. A more precise description about cleaning of the pressure filter can be found in chapter 9.7, about cleaning the suction filter in chapter 7.5.1.

At the end of the cleaning process, clean all nozzles. Nozzles can be cleaned only by means of a soft brush, compressed air or water. You can damage the nozzle when cleaning it with a hard item.



WARNING: In the case your spraying garniture is being cleaned by a high-pressure cleaning appliance, it is recommended to grease all parts after every single cleaning!

11.9 MAINTENANCE AND STORAGE AFTER USE

When the spraying season is over, find some time and prepare the spraying appliance for storage. Before storing the appliance, thoroughly clean the inside and the outside of the sprayer (regulator, pump, sieves, selection valves, nozzles, etc.). When the cleaning is done make sure that there is no water left in the valves, the filters, the pump, the nozzles, etc. Do not maintain the sprayer until it has not been thoroughly cleaned.

11.9.1 HOSES

Check the tightness of all hoses and hose junctions. Replace damaged hoses with new ones. A damaged hose cost you a lot of time during spraying.

11.9.2 PAINT

Some insecticides contain solvents which affect the paint. Clean the corrosion of colourless parts of the spraying appliance and apply some new paint.

11.9.3 RESERVOIR

Make sure that there are no rests of insecticide inside the reservoir. Chemical agents must not stay in the reservoir for a long time, since they can fast shorten the durability of the reservoir and other parts. Make sure that the outflow valve is opened.

11.9.4 PRESSURE REGULATOR

Protect the pressure regulator against moisture and dust. It is recommended to grease moving parts with WD-40 or oil. There are further instructions about the maintenance of the regulator in chapter "MAINTENANCE OF THE REGULATOR".

11.9.5 PUMP

After every season, thoroughly clean the inside and the outside of the pump and prepare it for storage. Check the quantity of working hours and, if necessary, repair the pump (oil change, membrane change, sealing change, etc) or at least check the oil level, the sealing, etc. This is the most appropriate time of the season to perform some maintenance work. If you are not sure whether or not you can repair the pump on your own, leave the work to an authorized expert. You can find the description about maintenance work in the chapter "PUMPS".

11.9.6 DRIVE SHAFT-CARDAN

It is very important that the safety pin, which is attached to the head of the cardan shaft, is clean and greased. This assures that the shaft is safe to use.

Check the protective cover, the functioning and the condition of the cardan shaft every 40 working hours. Replace damaged parts with new ones.

Check the protective cover of the cardan shaft every 100 working hours and, if necessary, replace the sliding plates of the protection. Also check the condition of the cardan shaft. Pay special attention to the safety pin. Replace damaged parts with new ones.

11.9.7 BOLTS

IMPORTANT: Check the bolts, pins and especially safety pins, their tightness and their condition. If necessary, tighten or replace them.

11.9.8 HOSE JUNCTIONS

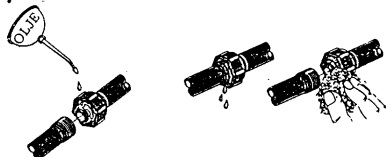

Reasons for bad sealing of hose junctions:

- missing O-rings or sealings;
- damaged or poorly inserted sealings;
- dry or re-formed sealing or O-ring;
- unsuitable joints;



In the case of bad sealing or leaking:

DO NOT TIGHTEN the joint too hard, since you can easily damage it. Take the joint apart and check the condition and position of the sealing or the O-ring, clean and grease it and reassemble the joint.

Use only non-mineral grease (bio-grease) for greasing.

REMEMBER:

- it is sufficient to tighten the joint by hand (radial sealing);
- it is sufficient to tighten the joint by a hand tool (axial sealing).

11.9.9 OTHER PARTS

The rest of the vital parts such as filter inserts, pouring sieve, additional equipment, etc. must be thoroughly cleaned, checked and replaced if necessary, too. Remove the remaining water and eventual sediments from parts such as suction filters and three-way valves. Grease all moving and sliding parts of the sprayer.



WARNING: If the temperatures get below zero, protect the spraying appliance against cold, which could damage it!

To protect the appliance against cold, follow the instructions written below:

- either remove all water from the pump, the regulator, the hoses, the filters and other elements of the sprayer;
- either store the appliance in a warm room;
- or use an agent against freezing (antifreeze) in accordance with the following procedure:

After you have finished cleaning the spraying appliance, completely empty the reservoir and pour at least 10 litres of antifreeze agent (a mixture of water and antifreeze) and turn on the pump. Open all valves on the regulator in order the antifreeze agent can reach all hoses and nozzles. At the end, empty the remaining agent from the reservoir into the tank and let the pump operate for few more minutes in order to pump the remaining agent into the tank.



WARNING: Make sure that the antifreeze agent is poured into appropriate tanks! Do not discard antifreeze agents in nature.

Protect the manometer against freezing by unscrewing it from the regulator and storing it in a warm room. The manometer must be stored in an upright position; on the opposite the glycerine filling can flow out of it.

12 POSSIBLE ERRORS

SIGNS FOR ERROR	POSSIBLE REASON	CHECK / REPAIR
There is no liquid coming out from the nozzles even though the main valve on the flow regulator is opened.	<ul style="list-style-type: none"> - damaged or incorrectly inserted valves in the pump; - closed manual valve on the suction side; - the suction or pressure filter is clogged; - there is some air inside the suction line. 	<ul style="list-style-type: none"> - check and if necessary replace valves in the pump; - check the valves on the suction line to the pump; - clean or replace the filter insert; - check the tightness of the hose junctions on the suction side.
The insecticide jet is unsymmetrical.	- inappropriate pressure in the air chamber.	- check the air pressure in the air chamber and fill it according to the data from chapter 11.1.
The pressure is falling according to the manometer; the working pressure can not be reached.	<ul style="list-style-type: none"> - the suction or pressure filter is clogged; - the pressure hose is broken; - the valve of the self-cleaning filter is opened; - incorrectly chosen or too worn nozzle inserts; 	<ul style="list-style-type: none"> - clean or replace the filter insert; - replace the hose; - close the valve of the self-cleaning filter; - check the flow rate through the nozzles – if it is bigger than 10%, replace the nozzles;
The pressure on the manometer is strongly swinging.	<ul style="list-style-type: none"> - there is some air inside the suction line; - the membranes are damaged. 	<ul style="list-style-type: none"> - check the tightness of the hose junctions on the suction side; - stop the pump immediately; - replace the membranes and the oil inside the pump;
The pump is noisy.	<ul style="list-style-type: none"> - too low oil level; - exceeded maximum rpm 	<ul style="list-style-type: none"> - control the oil level and add some if necessary; - control the rpm of the pump.
There is some insecticide in the oil of the pump.	- damaged membranes.	<ul style="list-style-type: none"> - stop the pump immediately; - replace the membranes and the oil inside the pump; - before mounting new membranes, thoroughly clean the inside of the pump with diesel oil.

13 TECHNICAL DATA

13.1 CHARACTERIZATION

The spraying appliances are characterised as follows:

For example: AGS 800 EN; BM 105; PR3 BF/5+1; 12MRX/5

AGS.....abbreviation for spraying appliances

800.....nominal capacity of the reservoir

EN.....version

BM 105.....pump type

PR3 BF/5+1.....regulator type

12MRX/5.....the working width of the spraying garniture; number of sections

All other technical data for individual components (pumps, flow regulator) can be gained from individual chapters.

13.2 OTHER TECHNICAL DATA

		Appliance type	
		400 EN	600 EN
Other technical data	l	8,0	10,0
	%	2,00	1,67
Reservoir capacity (nominal)	dm ³	400	600
Reservoir capacity (actual)	dm ³	425	755
Light diameter of the pouring opening	mm	390	390
Filling speed of the reservoir	l/min	>100	
Depth of the sieve in the pouring opening of the reservoir	mm	330	330
Capacity of the ablution reservoir	dm ³	60	60

		Appliance type	
		800 EN	1000, 1200 EN
Other technical data	l	10,2	10,2
	%	1,275	1,02
Reservoir capacity (nominal)	dm ³	800	1000
Reservoir capacity (actual)	dm ³	890	1100
Light diameter of the pouring opening	mm	390	390
Filling speed of the reservoir	l/min	>100	
Depth of the sieve in the pouring opening of the reservoir	mm	330	330
Capacity of the ablution reservoir	dm ³	100	100

13.3 DIMENSIONS

SPRAYER TYPE	RESERVOIR CAPACITY (l)	WORKING WIDTH (m) AND GARNITURE TYPE	DIMENSIONS (mm) A x B x C	WEIGHT (kg)
AGS 400 EN	400	10 MRX	122x241x209	300
		12 MRX	122x241x209	315
		15 MRX	123x300x193	335
		12 MY	126x261x265	351
AGS 600 EN	600	10 MRX	133x241x209	355
		12 MRX	133x241x209	370
		15 MRX	134x300x198	390
		12 MY	137x261x265	406
		12 MY-H	137x261x265	415
AGS 800 EN	800	10 MRX	141x241x227	373
		12 MRX	141x241x227	388
		15 MRX	142x300x198	408
		12 MY	145x261x265	424
		12 MY-H	145x261x265	433
		15 MY-E	145x270x274	575
AGS 1000 EN	1000	10 MRX	141x241x227	408
		12 MRX	141x241x227	423
		15 MRX	142x300x198	443
		12 MY	145x261x265	459
		12 MY-H	145x261x265	468
		15 MY-E	145x270x274	610
AGS 1200 EN	1200	10 MRX	141x241x227	425
		12 MRX	141x241x227	440
		15 MRX	142x300x198	460
		12 MY	145x261x265	476
		12 MY-H	145x261x265	485
		15 MY-E	145x270x274	627

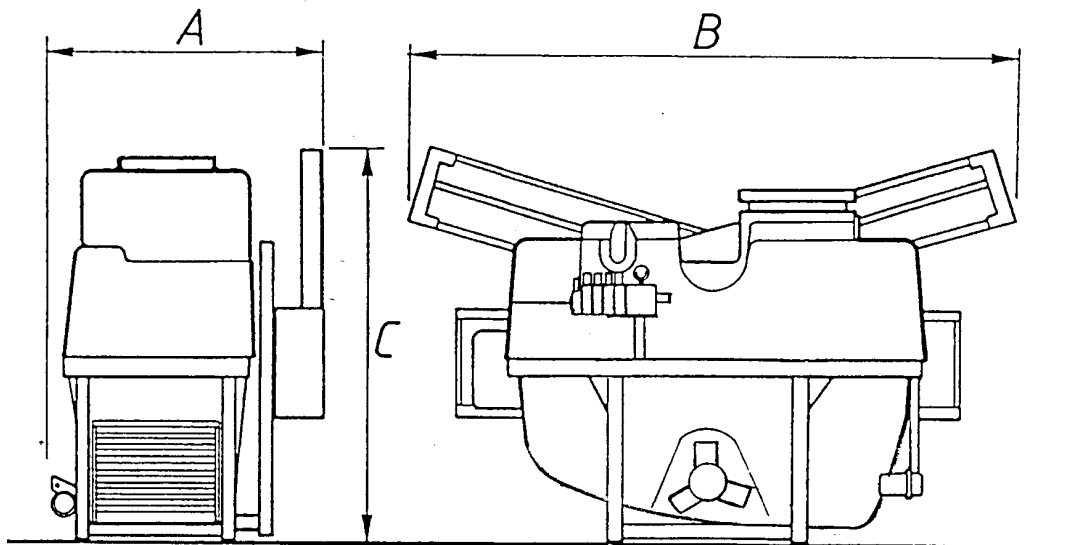

13.4 COMBINATIONAL METRICS

BASIC VERSIONS	SPRAYER TYPE (reservoir capacity)					PUMP				SPRAYING GARNITURE TYPE					
	400 EN (400 l)	600 EN (600 l)	800 EN (800 l)	1000 EN (1000 l)	1200 EN (1200 l)	BM 65/30	BM 105/20, BP 105	BP 125	BM 150/20, BP 151	10 MRX	12 MRX	15 MRX	12 MY	12 MY-H	15 MY-E
1	X					X				X					
2	X						X			X	X	X	X	X	
3	X							X		X	X	X	X	X	
4		X					X			X	X	X	X	X	
5		X						X		X	X	X	X	X	
6			X				X			X	X	X	X	X	X
7			X					X		X	X	X	X	X	X
8			X						X	X	X	X	X	X	X
9				X				X		X	X	X	X	X	X
10				X					X	X	X	X	X	X	X
11					X			X		X	X	X	X	X	X
12					X				X	X	X	X	X	X	X

13.5 CONNECTION FOR FLOW RATE MEASURING OF THE PUMP

The flow meter can be connected to the return line of the flow regulator. Remove the hose attachment (code E 19016 – see the picture in the catalogue “FLOW REGULATOR PR-3) and mount the regulator to its place which is connected through the flow regulator into the reservoir. An enclosed attachment with an appropriate sealing is enclosed with the sprayer.

13.6 CONNECTION FOR PRESSURE MEASURING

The connection for the control manometer has a thread R ¼”, which can be found at the upper side of the regulation valve on the pressure regulator (see the picture in the catalogue, “REGULATION VALVE PR-3).

To connect the manometer to the regulator, unscrew the cap (code E 15783) and screw the manometer into the thread.

13.7 MEASUREMENT OF LIQUID FLOW RATE THROUGH THE NOZZLE

To measure the liquid flow rate through the nozzle, you will need a piece of soft flexible hose with an inner diameter of 25 mm or 1” and an appropriate container (it is recommended to use a measuring cylinder). Simply put on the hose on the nozzle and measure the liquid flow rate by catching the liquid of individual nozzles into the measuring cylinder. You will also need a stopwatch or a wristwatch. The measurement time is one minute. If you have performed the measurement in less than one minute, calculate the liquid flow rate to one minute.

If the liquid flow rate of a nozzle at a specific pressure exceeds the table values for more than 10% than the nozzle insert is worn and needs to be replaced.

13.8 DISPOSAL OF THE SPRAYER

Once the spraying appliance can not be used anymore, you will have to clean it completely, take it apart and sort the individual components of the sprayer by material. The components must be handed over to an organisation which deals with waste materials. The reservoir and other plastic parts of the sprayer can be recycled or burned in special incineration sites. The metal parts can be sorted out as scrap metal. Consider the local legislation for waste materials.

13.9 MATERIALS AND RECYCLING

RESERVOIR.....PEHD (polyethylene of high density)

13.10 FLEXIBLE HOSES.....RUBBER, PVC

FRAME.....STEEL

VALVES, REGULATOR, NOZZLE HOLDERS.....more or less PA with fibre glass

NOZZLE HOLDER HOSES.....PE (polyethylene)

13.11 GENERAL INSTRUCTIONS FOR SPRAYING

For a successful spraying, the appropriate water quantity, right nozzle selection and a precise consumption calculation are of major importance. It is recommended to stick to the following order when it comes to preparing of the spraying mixture and spraying:

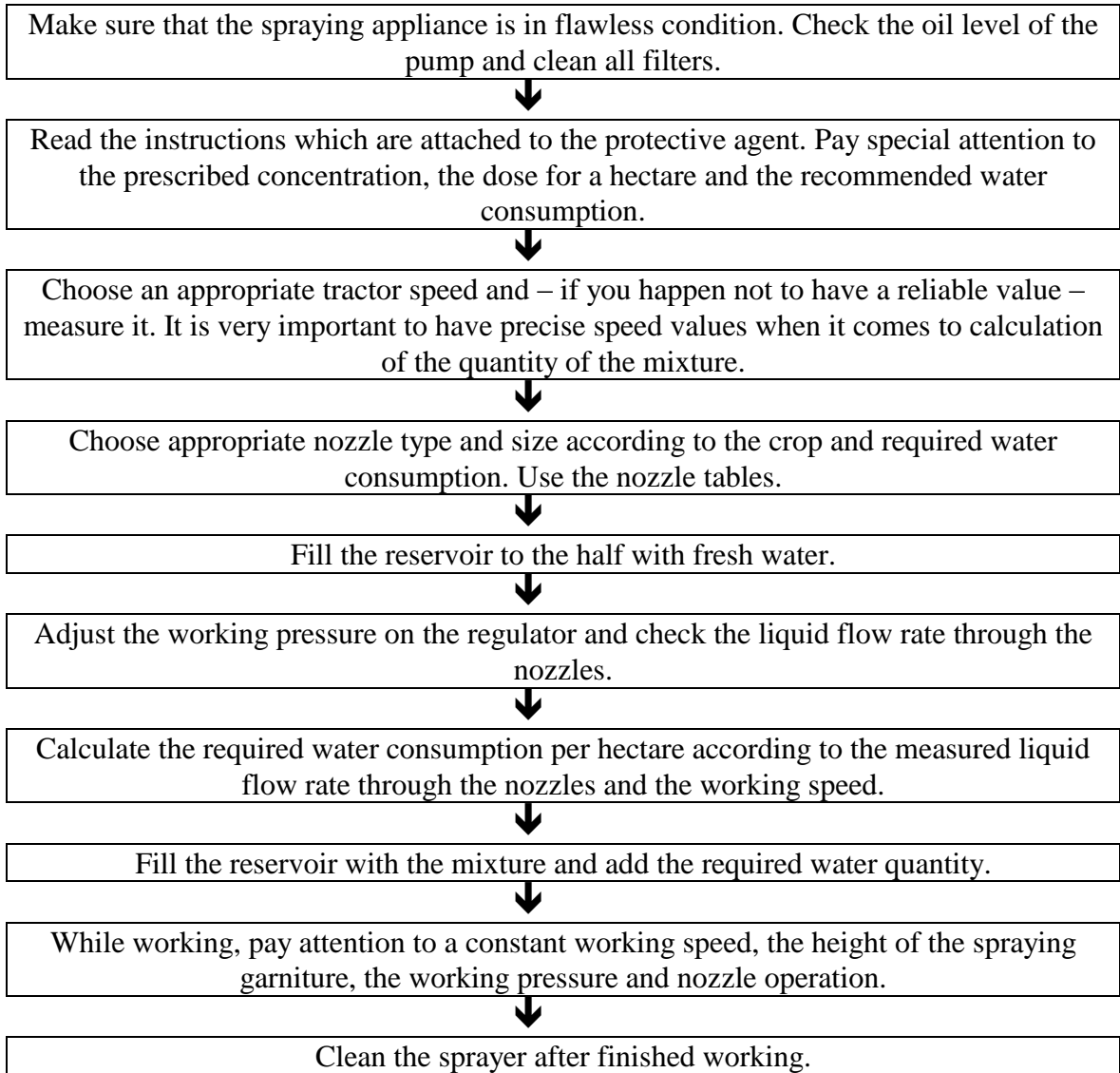

14 NOZZLE TYPES IN FARMING

14.1 NOZZLES WITH FLAT JET

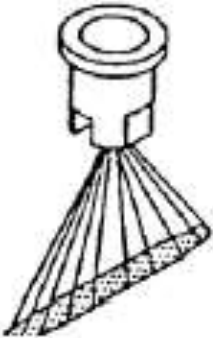

This kind of nozzles is principally used for spraying with herbicides, insecticides and fungicides. The insecticide is precisely distributed along the whole working range of the nozzle. At lower pressure, the drops are bigger and less sensitive to wind and vice-versa. The recommended working height is 0.5 meter above the crop.

For reasons of correct overlapping of the jets, the nozzle adjustment is very important. The nozzles must be rapt for 5°-10° according to the garniture.

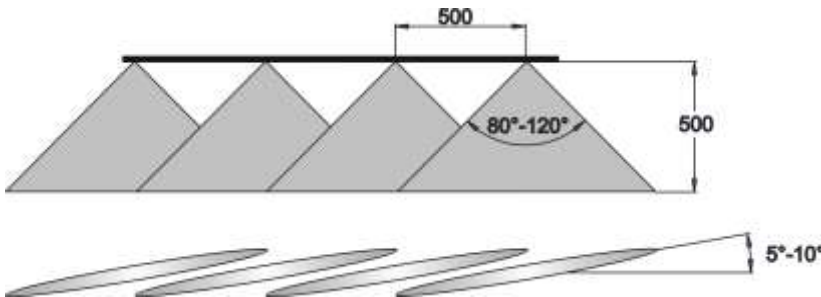

Recommended working pressure:

- Herbicides: 1,5-3 bar
- Fungicides: 3 -5 bar
- Insecticides: 3 -5 bar

14.2 WHIRL NOZZLES

The jet of such nozzles is formed like a rotating cone. They consist of a whirling and a spraying part. Spraying parameter settings should be such that the overlap of jets between two nozzles is minimal. The main characteristic of these nozzles are smaller drops, the insecticide distribution is worse. They are suitable when spraying with fungicides and insecticides.

- Recommended working pressure: 2 - 10 bar
- Recommended working height: 0,5 meter.

A – Distance between nozzles

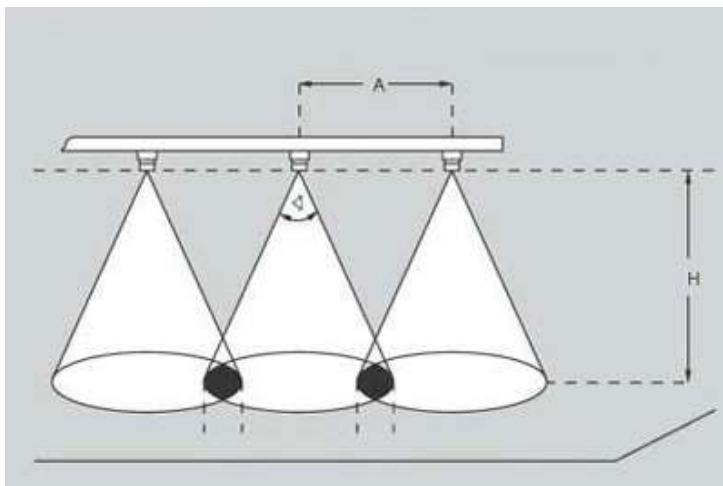

H – Height of nozzles above the crops

Δ – Spraying angle

14.3 WIND INFLUENCE

If possible, avoid spraying in windy conditions. If this is not possible, remember the following:

- use special nozzles (“Anti drift”, injection nozzles, etc.)
- use nozzles with larger flow rate
- lower the pressure during spraying
- use nozzles which spray bigger drops (400 µm)
- reduce the working speed
- sprinkle in wind direction.

14.4 WATER CONSUMPTION DURING SPRAYING

Adjust the water consumption to the way of working of the protection agent which will be used and the growth of the crop. Normally, the water consumption per hectare ranges from 100 to 600 litres. When using herbicides, which are commonly sprayed on weedy crops bare of plants, use smaller water quantities (from 100 to 300 litres). Too much water can lower the spraying efficiency, especially when using herbicides which are absorbed through the leaves of the weed. When spraying plants with fungicides and insecticides, a higher amount of water is normally used. Too much water, however, can cause insecticide to drip of the leaves and therefore loss of insecticide.

15 TABLES

TABLE 1: Flow rate of spraying nozzles type LECHLER (v l/min):

REMARK: THE NOZZLE FLOW RATES ARE ALWAYS THE SAME FOR THE SAME COLOUR MARKINGS OF DIFFERENT TYPES (ST, LU, AD, ID, TR, ETC.) AND NOZZLE MATERIALS.

NUMBER:	NOZZLE TYPE:	NOZZLE COLOUR:	WORKING PRESSURE (bar)						
			2,0	2,5	3,0	3,5	4,0	4,5	5,0
	110015	GREEN	0,48	0,53	0,59	0,63	0,68	0,72	0,76
019.48.062	11002	YELLOW	0,63	0,71	0,78	0,85	0,90	0,96	1,01
019.48.063	11003	BLUE	0,95	1,06	1,17	1,26	1,35	1,44	1,52
019.48.064	11004	RED	1,26	1,42	1,55	1,68	1,80	1,91	2,02
019.48.065	11005	BROWN	1,57	1,77	1,94	2,10	2,25	2,39	2,48
019.48.066	11006	GREY	1,88	2,11	2,32	2,51	2,69	2,86	3,01
019.48.067	11008	WHITE	2,50	2,81	3,08	3,33	3,57	3,79	4,00

TABLE 2: Liquid consumption per hectare (l/ha) according to the flow rate of the nozzle (l/min) and working speed (km/h) – applies only to spraying garnitures with 0.5 meter distance between the nozzles:

l/min	WORKING SPEED (km/h)												
	3,0	3,5	4,0	4,5	4,8	5,0	5,2	5,4	5,6	5,8	6,0	6,5	7,0
0,50	200	171	150	133	125	120	115	111	107	103	100	92	86
0,60	240	205	180	160	150	144	138	133	128	124	120	110	103
0,70	280	240	210	187	175	168	162	156	150	145	140	129	120
0,80	320	274	240	213	200	192	185	178	171	165	160	148	137
0,90	360	309	270	240	225	216	208	200	193	186	180	166	154
1,00	400	343	300	266	250	240	231	222	214	207	200	185	171
1,10	440	377	330	293	275	264	254	244	236	228	220	203	188
1,20	480	411	360	320	300	288	277	267	257	248	240	222	206
1,30	520	446	390	347	325	312	300	289	278	269	260	240	223
1,40	560	480	420	373	350	336	323	311	300	290	280	258	240
1,50	600	514	450	400	375	360	346	333	321	310	300	277	257
1,60	640	549	480	427	400	384	369	355	343	331	320	295	274
1,70	680	583	510	453	425	408	392	378	364	352	340	314	291
1,80	720	617	540	480	450	432	415	400	386	372	360	332	309
1,90	760	651	570	507	475	456	438	422	407	393	380	350	325
2,00	800	685	600	533	500	480	461	444	428	413	400	369	342
2,10	840	720	630	560	525	504	484	466	540	434	420	387	360
2,20	880	754	660	586	550	528	507	488	471	455	440	406	377
2,30	920	788	690	613	575	552	530	511	492	575	460	424	394
2,40	960	822	720	640	600	576	553	533	514	496	480	443	411
2,50		857	750	666	625	600	577	555	535	517	500	461	428
2,60		891	780	693	650	624	600	577	557	537	520	480	445
2,70		925	810	720	675	648	623	600	578	558	540	598	463
2,80		960	840	746	700	672	646	622	600	579	560	517	480
2,90		994	870	773	725	696	669	644	621	600	580	535	497
3,00			900	800	750	720	692	666	643	620	600	554	514



Remark: check the actual flow rate of the nozzles by measuring it. If the flow rate of a nozzle at a specific pressure exceeds the table values for more than 10% than the nozzle insert is worn and needs to be replaced.

15.1 HOW TO USE THE TABLES

15.1.1 NOZZLE SELECTION

Example:

You have the following data:

- desired consumption per hectare of 400 l
- working speed: 6 km/h

1. In the speed column for 6 km/h of table 2 find the desired consumption per hectare 400 l/ha.
2. See the flow rate of the nozzle on the left side of the table; in our case, this is 2,00 l/min.
3. Select the appropriate nozzle at specific pressure from table 1: e.g. TABLE 1, NOZZLE LECHLER, brown colour at a pressure of 3.2 bar.

15.1.2 SELECTING THE APPROPRIATE SPEED AND WORKING PRESSURE

Example:

- desired consumption per hectare of 400 l/ha
- red LECHLER nozzles built in
- desired pressure between 2 and 4 bars
- desired speed between 4 and 6 km/h

1. Find your built in nozzles in table 1; the RED LECHLER nozzle has a flow rate of 1.26 l/min at a pressure of 2 bar; at a pressure of 4 bars the flow rate is 1.8 l/min.
2. Find the consumption value of 400 l/ha at a nozzle flow rate between 1.2 and 1.8 l/min in table 3; find the speeds 4-6 km/h in the vertical column. The results are:
 - 4.5 km/h at a pressure of 2.8 bar
 - 4.8 km/h at a pressure of 3.2 bar...

15.2 DIFFERENT CALCULATIONS

The water consumption values can be taken from the tables or calculated in accordance with the following equation:

$$\text{WATER CONSUMPTION PER HECTARE (l/ha)} = \frac{1200 \times \text{FLOW RATE OF THE NOZZLE (l/min.)}}{\text{WORKING SPEED (km/h)}}$$

The required flow rate of a nozzle per hectare and the working speed can be calculated with the help of the following equation:

$$\text{FLOW RATE OF THE NOZZLE (l/min.)} = \frac{\text{CONSUMPTION (l/ha)} \times \text{WORKING SPEED (km/h)}}{1200}$$

The simplest way to determine the tractor's speed is to measure a certain distance and the required time to pass this distance:

$$\text{SPEED (km/h)} = \frac{\text{PASSED DISTANCE (m)} \times 3,6}{\text{DRIVING TIME (s)}}$$

