

***Model '683'***

---

***Small Animal Ventilator***

---

***User's Manual***

---

*'683' Small Animal Ventilator*

*MA1 55-3438*



**HARVARD**

---

A P P A R A T U S

Publication 5375-001-REV-E

# WEEE/RoHS Compliance Statement

## EU Directives WEEE and RoHS

To Our Valued Customers:

We are committed to being a good corporate citizen. As part of that commitment, we strive to maintain an environmentally conscious manufacturing operation. The European Union (EU) has enacted two Directives, the first on product recycling (Waste Electrical and Electronic Equipment, WEEE) and the second limiting the use of certain substances (Restriction on the use of Hazardous Substances, RoHS). Over time, these Directives will be implemented in the national laws of each EU Member State.

Once the final national regulations have been put into place, recycling will be offered for our products which are within the scope of the WEEE Directive. Products falling under the scope of the WEEE Directive available for sale after August 13, 2005 will be identified with a "wheelie bin" symbol.

Two Categories of products covered by the WEEE Directive are currently exempt from the RoHS Directive - Category 8, medical devices (with the exception of implanted or infected products) and Category 9, monitoring and control instruments. Most of our products fall into either Category 8 or 9 and are currently exempt from the RoHS Directive. We will continue to monitor the application of the RoHS Directive to its products and will comply with any changes as they apply.

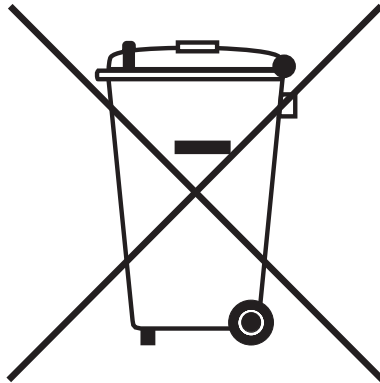

- **Do Not Dispose Product with Municipal Waste**
  - **Special Collection/Disposal Required**

# Table of Contents

---

1

Harvard Apparatus Model '683' Small Animal Ventilator User's Manual

<b>SUBJECT</b>	<b>PAGE NO.</b>
<b>General Information - Warranty &amp; Repairs</b> .....	<b>2</b>
<b>General Safety Summary</b> .....	<b>3</b>
<b>Specifications</b> .....	<b>4</b>
<b>Description &amp; Features</b> .....	<b>5</b>
<b>Voltage Selection</b> .....	<b>6</b>
<b>Fuse Replacement</b> .....	<b>6</b>
<b>Pump Operation:</b>	
Connecting to Animal .....	7
Selecting Rate & Volume .....	8
Setting Volume & Rate .....	9
Using Gas Mixtures.....	9
Creating a PEEP .....	9
<b>Cleaning &amp; Maintenance</b> .....	<b>10</b>
<b>Changing Piston &amp; Cylinder</b> .....	<b>11-12</b>

# General Information

## Serial Numbers

All inquires concerning our product should refer to the serial number of the unit. Serial numbers are located on the rear of the chassis.

## Calibrations

All electrical apparatus is calibrated at rated voltage and frequency. While the flow will stay calibrated, the peak will vary.

## Warranty

Harvard Apparatus warranties this instrument for a period of one year from date of purchase. At its option, Harvard Apparatus will repair or replace the unit if it is found to be defective as to workmanship or material.

This warranty does not extend to damage resulting from misuse, neglect or abuse, normal wear and tear, or accident.

This warranty extends only to the original customer purchaser.

**IN NO EVENT SHALL HARVARD APPARATUS BE LIABLE FOR INCIDENTAL OR CONSEQUENTIAL DAMAGES.** Some states do not allow exclusion or limitation of incidental or consequential damages so the above limitation or exclusion may not apply to you. **THERE ARE NO IMPLIED WARRANTIES OF MERCHANTABILITY, OR FITNESS FOR A PARTICULAR USE, OR OF ANY OTHER NATURE.** Some states do not allow this limitation on an implied warranty, so the above limitation may not apply to you.

If a defect arises within the two-year warranty period, promptly contact *Harvard Apparatus, 84 October Hill Road, Building 7, Holliston, Massachusetts 01746-1371* using our toll free number 1-800-272-2775. Goods will not be accepted for return unless an RMA (returned materials authorization) number has been issued by our customer service department. The customer is responsible for shipping charges. Please allow a reasonable period of time for completion of repairs, replacement and return. If the unit is replaced, the replacement unit is covered only for the remainder of the original warranty period dating from the purchase of the original device.

This warranty gives you specific rights, and you may also have other rights which vary from state to state.

## Repair Facilities and Parts

Harvard Apparatus stocks replacement and repair parts. When ordering, please describe parts as completely as possible, preferably using our part numbers. If practical, enclose a sample or drawing. We offer a complete reconditioning service.

## CAUTION

This ventilator is not registered with the FDA and is not for clinical use on human or veterinary patients. It is intended for research use only.

<p><b>CAUTION</b> FOR RESEARCH USE ONLY NOT FOR CLINICAL USE ON PATIENTS</p>
--

# General Safety Summary

Please read the following safety precautions to ensure proper use of your ventilator. To avoid potential hazards and product damage, use this product only as instructed in this manual. If the equipment is used in a manner not specified by the manufacturer, the protection provided by the equipment may be impaired.

## ***To Prevent Hazard or Injury:***

### **Use Proper Line Cord**

Use only the specified line cord for this product and make sure line cord is certified for country of use.

### **Ground the Product**

This product is grounded through the grounding conductor of the power cord. To avoid electric shock, the grounding conductor must be connected to earth ground. Before making any connections to the input or output terminals of the product, ensure that the product is properly grounded.

### **Make Proper Connections**

Make sure all connections are made properly and securely.

### **Orient Equipment Properly**

Do not position the equipment such that it is difficult to reach the disconnecting device.

### **Observe all Terminal Ratings**

Review the operating manual to learn the ratings on all connections.

### **Use Proper Fuse**

Use only specified fuses with product.

### **Avoid Exposed Circuitry**

Do not touch any electronic circuitry inside of the product.

### **Do Not Operate with Suspected Failures**

If damage is suspected on or to the product do not operate the product. Contact qualified service personnel to perform inspection.

### **Place Product in Proper Environment**

Review the operating manual for guidelines for proper operating environments.

### **Observe all Warning Labels on Product**

Read all labels on product to ensure proper usage.



**CAUTION**  
*Refer to Manual*



*Protective Ground  
Terminal*

# Specifications

## '683' Small Animal Ventilator Specifications

<b>Rate</b>	Adjustable from 30 to 150 strokes/min while the ventilator is running
<b>Phase Ratio</b>	1:1 fixed
<b>Dimensions, H x L x W</b>	25 x 32.5 x 20 cm (10 x 13 x 8 in)
<b>Weight</b>	9.5 kg (21lbs)
<b>Power</b>	100-20 VAC/200-230 VAC, 0.7A/0.35A max., 50/60 Hz
<b>Stroke Rate</b>	Continuously variable from 30 to 150 strokes/min while the ventilator is running, with LIGHT-EMITTING DIODE (LED) DISPLAY.
<b>Volume</b>	Adjustable from 0.2 to 5.0 cc/stroke or 1.5 to 30.0 cc/stroke while the ventilator is running
<b>Environmental:</b>	
<b>Operating Temperature</b>	0°C to 40°C (32°F to 104°F)
<b>Operating Humidity</b>	20% to 80% RH, non-condensing
<b>Installation Category</b>	II
<b>Pollution Degree</b>	1
<b>Port:</b>	
<b>Part Number</b>	5121-074
<b>Size</b>	
<b>ID</b>	.128" (3.25mm)
<b>OD</b>	.188" (4.78mm)
<b>Catalog No.</b>	55-0000
<b>Accessories</b>	
<b>55-5282</b>	Overhaul Kit for 5cc Small Animal Ventilator; contains O-rings, valve springs, lubricants, etc. to overhaul Ventilator
<b>55-5283</b>	Overhaul Kit for 30cc Small Animal Ventilator; contains O-rings, valve springs, lubricants, etc. to overhaul Ventilator

# Description & Features

---

The current MODEL 683 (NEW STYLE WITH DIGITAL READOUT) is an improved volume controlled small animal/rodent respirator that is functionally identical to previous MODELS (680, 681, and 683 OLD STYLE WITHOUT DIGITAL READOUT) with the following major changes:

- New, stronger motor and motor speed control with LED (light emitting diode) read-out of rate (stroke rate or breaths/min).
- A new design of the vertical slide valve that has no "O"-Rings or passive check valves and requires no adjustments.

*NOTE: In any correspondence, please refer to the ventilator as "MODEL 683 with LED RATE READ-OUT"*

The MODEL 683 is a positive volume ventilator intended to meet the respiratory requirements of small laboratory animals weighing up to 5 kg (11 lb), covering rodents through rabbits.

This ventilator is furnished with two interchangeable piston/cylinder assemblies of 0.2 to 5.0 ml/breath (5 CC) and 1.5 to 30.0 ml/breath (30 CC). The smaller cylinder is factory installed, and the larger one is supplied separately. The mechanical design features a linkage that enables the piston to touch the end of the cylinder at each stroke regardless of the volume. This assures that all the air/gas mixture taken into the ventilator is expelled at each stroke.

A positive mechanical slide valve is actuated by a cam on the motor to synchronize inspiration and expiration with the motion of the piston. Any **NON-EXPLOSIVE** gas/air mixture can be used with the ventilator. A three-way slide valve is attached to the mechanism plate at the end of the cylinder and actuated by a cam on the motor.

These ventilators (MODELS 680, 681, 683 OLD or NEW STYLES) are **NOT TO BE USED IN AN EXPLOSIVE ATMOSPHERE OR WITH ANY EXPLOSIVE GASES SUCH AS ETHER OR CYCLOPROPANE, ETC. THESE VENTILATORS ARE NOT EXPLOSION-PROOF.**

# Voltage Selection/Fuse Replacement

## Voltage Selection

1. The '683' Ventilator is equipped with a 115/230V selector feature, which is incorporated into the power entry module located on the side of the unit (see figure below). The Ventilator is shipped from the factory with the voltage selector set at 115V. To change voltage from 115V to 230V, follow these steps:
  - a. Turn off main power, and disconnect power cord.
  - b. Using a small flathead screwdriver, pry open the fuse access door on the power entry module (see figure below).
  - c. Remove fuse holder by using the small flathead screwdriver.
  - d. Rotate the red fuse holder 180 deg. and install back into power entry module.
  - e. Close small access door firmly until fully closed. In power entry module window (see detail below) 230V should be seen.
  - f. Re-install power cord.
2. Turn on main power switch located on the rear panel. The display will now illuminate. The number displayed is the current strokes per minute rate.

## Fuse Replacement

### **Key Information**

1. Make sure power cord is disconnected from the main power supply before servicing the fuse.
2. Use only Type 3AG, 1/4" x 1-1/4", 0.75 amp, 250 volts; Type T (time delay) fuses (Harvard Apparatus part # 5153-554 or equivalent).

Turn off power and remove power cord from power module. Use a straight blade screwdriver to pry open the access door. Remove the fuse holder and then remove the fuses from this holder as shown in the figure below. Replace fuses using only 0.75A amp, 250 volts, Type T fuses. Then replace the fuse holder.

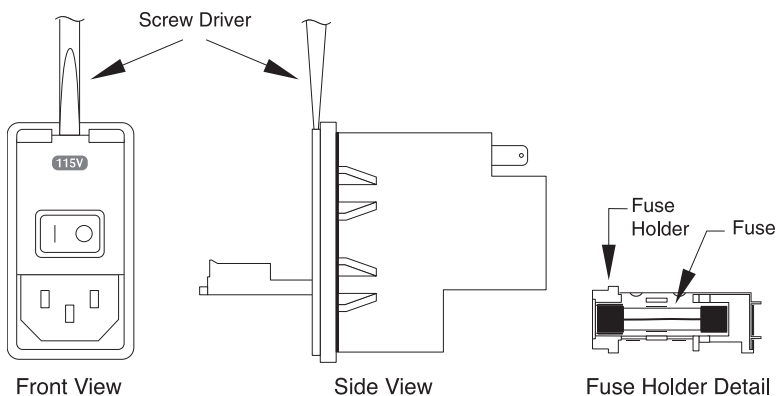

*Note: A non-operator-replaceable fuse exists inside of the equipment. This fuse is rated T 40mA 250V, 5 x 20mm.*



# Operating the Pump

## Connection to the Animal

The vertical slide valve has four ports (see figure below):

- The top port is the return channel from the animal, which leaves the Pump at the port on the side. It is at this top port that expired air can be collected or recycled.
- The middle port is the room air/gas channel to the animal.
- The bottom port is the room air or gas mixture intake.

*Note: It is important that the tubes to and from the animal be as short as possible.*

The actual connection to the animal can be either:

- Tracheal cannula
- Endotracheal tube with or without a cuff

A selection of tracheal cannula and endotracheal tubes are listed in the Harvard Bioscience Catalog. It is important that the volume of tubing shared by inspired and expired air (dead space) be kept to a minimum by having the "Y" or "T" connector as close to the animal as possible.

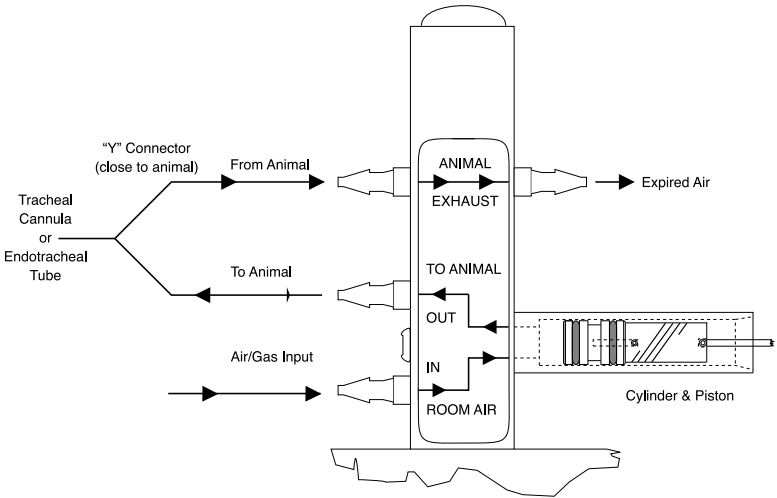

# Operating the Pump (Cont'd)

## Ventilator Graph

Tidal Volume vs. Weight & Rate  
for Laboratory Mammals in Resting State.  
(Apparatus dead space must be added)

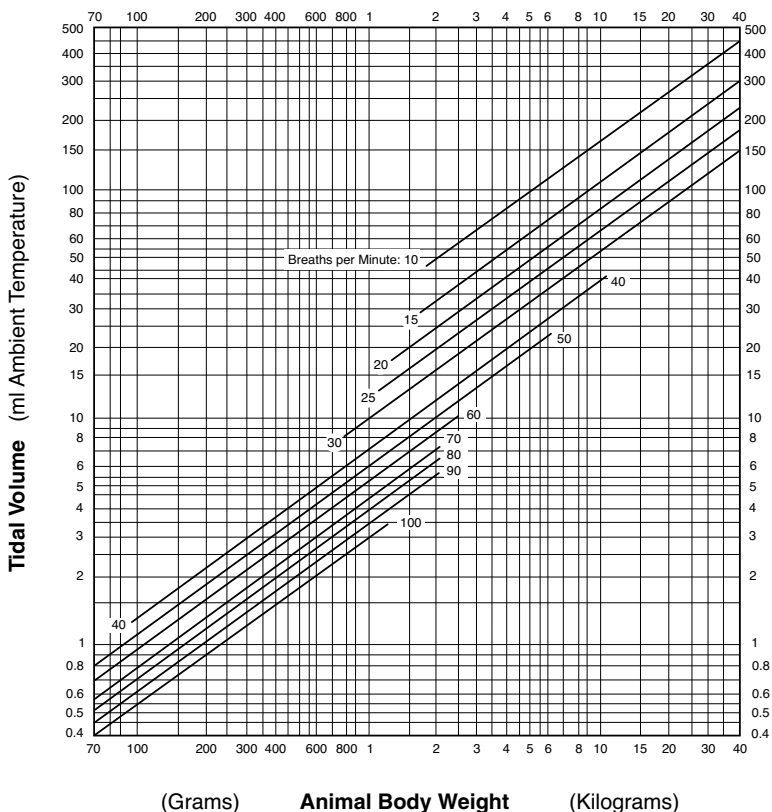

### Selection of Rate and Volume

Refer to the Ventilator Graph (above) to select the appropriate tidal volume and respiration rate as a function of animal body weight. As a rough guide an adult rat will weigh between 200 and 500 grams with tidal volumes between 0.6 to 1.25 cm<sup>3</sup> with respiration rates between 66 to 210 breaths/min. The average rate is 100 breaths/min. For most rodents the 5 cc cylinder will be adequate.

# Operating the Pump (Cont'd)

---

## Setting Volume

The volume delivered is read by observing the excursion of the O-ring, on the piston, which is closest to the valve block. This piston O-ring excursion is relative to the volume scale on the outside of the cylinder wall. Volume change is accomplished while the Pump is running by turning "volume" knob in the desired direction.

## Setting Rate

Adjust the "Rate" control until the desired rate appears on the LED display. Avoid running the Pump at rates exceeding 150 breaths/min for periods in excess of 2 hours.

**CAUTION** - *Do not over inflate the animal. A good rule of thumb is to observe the depth of respiration in the normal calm unanesthetized animal and adjust the volume to approximate this respiration depth when the animal is attached to the ventilator.*

## Use of Gas Mixture

It is possible to introduce non-explosive air/gas mixtures into the lower room air port. However, the source of gas mixture is usually from a tank delivering gas is at a constant rate while the Pump takes in air/gas intermittently. Some sort of buffer/expansion chamber must be provided between the tank and the Pump. Harvard Apparatus offers a connection kit (73-3076) to depressurize the gas prior to entering the ventilator. This Pump is not designed to take air/gas inputs under pressure.

## Creating a Positive End-Expiratory Pressure (PEEP)

To create a PEEP pressure when using the ventilator, simply connect a length of tubing to the "Exhaust" port and submerge the other end in a column of water. A cylinder and clip are provided on the chassis for this purpose. The depth of the end of the tubing (in cm) below the water surface will give the PEEP pressure in cmH<sub>2</sub>O.

## Cleaning

To clean the exterior surfaces, use a lint-free cloth to remove loose dust. Use care to avoid scratching the clear display window. For more efficient cleaning, use a soft cloth dampened with water or an aqueous solution of 75% isopropyl alcohol.

## Maintenance

No special maintenance is required other than periodic lubrication of the piston O-rings and the slide valve with the special non-toxic grease provided. To get to the slide valve for lubrication:

1. Remove the four screws holding the valve to the 1/4" aluminum black back plate.
2. Remove the screws in front that hold the cylinder and valve together.
3. Lift entire valve assembly up and out of Pump.
4. Pull stainless steel valve rod and spring assembly free of valve block.
5. Lubricate sparingly.

## Model 683 Rodent Ventilator Replacement Parts

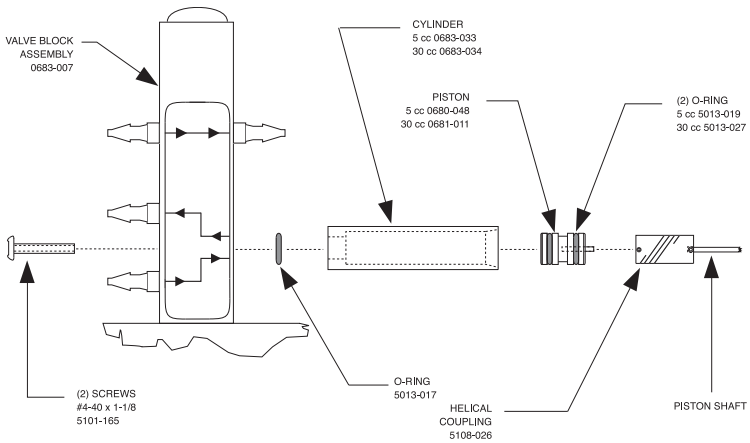

## Lubrication

This Model 683 Respiration Pump is shipped with Pink Grease to lubricate piston O-rings in cylinders and the inside of the slide valve.

# Changing Piston and Cylinder

This Respirator Pump is furnished with a 5 cc piston and cylinder installed in the Pump. A 30 cc cylinder and piston is also supplied for users that require larger tidal volumes.

**Note: It is extremely important when changing piston and cylinders that they be aligned to be concentric and in line with the piston shaft.**

The cylinder is fastened to the 4 port vertical slide valve by means of two screws located between the "room air inlet" port and the "to animal" port on the front of the slide valve.

The vertical slide valve is fastened to the black 1/4" aluminum sub base by four screws located on the opposite side from the printed label. By using these six screws, two in front and four on the side, alignment adjustments are made (see below).

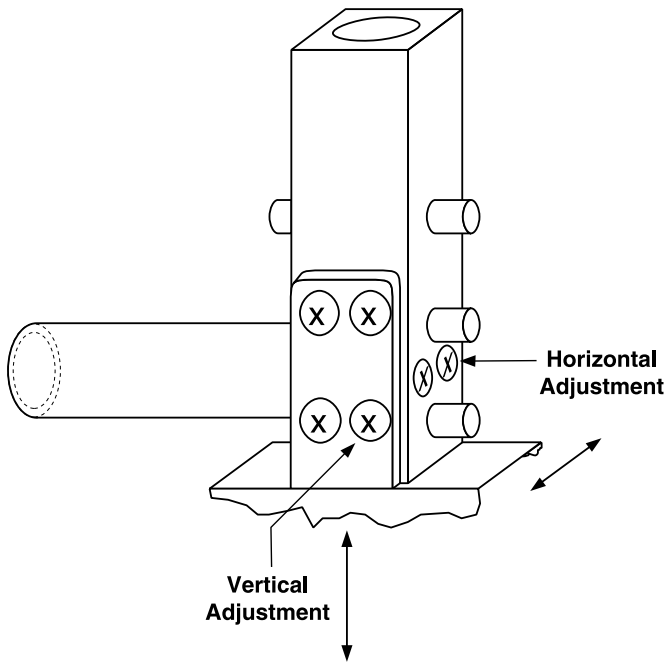

# Changing Piston and Cylinder (Cont'd)

## To remove the cylinder and piston

1. Set the pump volume to maximum.
2. Run Pump at lowest speed and stop the Pump when the helical coupling is exposed.
3. Using a 0.050 Allen wrench (provided), disconnect the white piston from the coupling, leaving the coupling on the piston shaft.
4. Remove the two screws located in the front of the slide valve.
5. Remove piston and cylinder.
6. Be careful to save the O-ring that is recessed in the slide valve block between the screws. The O-ring provides the airtight seal between the plastic cylinder and the valve block.

## To install the piston and cylinder

1. Pick out the new piston and cylinder.
2. Using pliers, remove the piston and lubricate with the pink grease provided.
3. Insert the lubricated piston in the cylinder so that the rear of the piston is flush with the rear of the cylinder with the 1/8" diameter coupling stud protruding.
4. Fasten the cylinder to the valve block with the two screws, making sure the O-ring is in place. Do not tighten these two screws completely, but just enough to hold the cylinder in place.
5. The object of alignment is to have the stud at the end of the piston be exactly in line with its mating hole in the helical coupling. This insures that the piston moves freely within the cylinder without undue friction.
6. The two screws at the front of the valve block control left to right alignment while the four screws at the rear of the slide valve control up and down alignment. By adjustment of these 6 screws the proper alignment can be made. Remember that the screws interact with one another so the procedure may have to be repeated one or more times.
7. When proper alignment is achieved, the helical coupling should be connected. If alignment is correct, the coupling should slide onto the piston stud without bending of the piston rod.

# Repair Kit

## Repair Instructions for the 683 Respirator

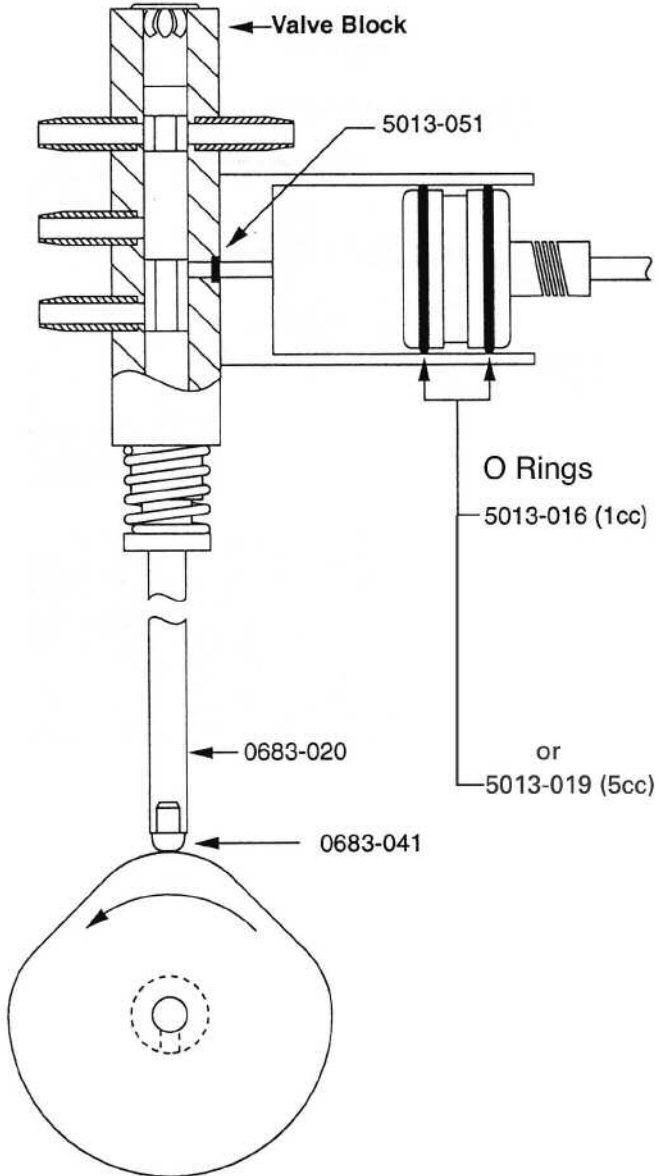

# Notes

---



# Notes

---

# Declaration of Conformity

Application of  
Council Directive(s): *73/23/EEC, 89/336/EEC*

Standard(s) to which  
Conformity is Declared:

Safety: *EN 61010-1, 2<sup>nd</sup> Edition (2001)*

Emissions/Immunity: *EN 61326:1997 w/ A1:1998  
EN 61000-4-2:1995  
EN 61000-4-3:1996  
EN 61000-4-4:1995  
EN 61000-4-5:1995  
EN 61000-4-6:1996  
EN 61000-4-11:1994  
EN 61000-3-2:2000 w/ A.14  
EN 61000-3-3:1995 w/ 1997*

Manufacturer's Name: *Harvard Apparatus*

Manufacturer's Address: *84 October Hill Road  
Holliston, Massachusetts 01746  
U.S.A.*

Type of Equipment: *Small Animal Ventilator*

Model No.: *683*

I, the undersigned, hereby declare that the equipment specified above conforms to the above Directive(s) and Standard(s).

EMC compliance was evaluated by Intertek/ETL Semko.

Reference test report file number: Box 3091685-001

Place: *United States of America*

Date: *February 2006*

CE

**HARVARD**  

---

**A P P A R A T U S**

*Beth Bauman*  
\_\_\_\_\_  
(Signature)

**Beth Bauman**  
\_\_\_\_\_  
(Full Name)

**VP Engineering / Operations**  
\_\_\_\_\_  
(Position)