

Model 3502 Optical Chopper



User's Manual

 **New Focus**[™]
A Newport Company

Declaration of Conformity

We declare that the accompanying product, identified with the **CE** mark, complies with requirements of the Electromagnetic Compatibility Directive, 2004/108/EC and the Low Voltage Directive 2006/95/EC.

Model Number: 3502

Year mark affixed: 2014

Type of Equipment:

Electrical equipment for measurement, control, and laboratory use in industrial locations.

Manufacturer:

Newport Corporation
1791 Deere Avenue
Irvine, CA 92606

Standards Applied:

Compliance was demonstrated to the following standards to the extent applicable:

- BS EN61326-1: 2006 “Electrical equipment for measurement, control and laboratory use – EMC requirements”.
- BS EN 61010-1:2010, “Safety requirements for electrical equipment for measurement, control and laboratory use”.



Malcolm Minty
Site General Manager, New Focus
Newport Corporation
1791 Deere Ave, Irvine, CA92606 USA

Warranty

New Focus warrants that this product will be free from defects in material and workmanship and will comply with New Focus's published specifications at the time of sale for a period of one year from the date of shipment. If found to be defective during the warranty period, we will either repair or replace the product at our discretion.

To exercise this warranty, write or call your local New Focus office or representative, or contact Newport headquarters in Irvine, California. You will be promptly assisted and given return instructions. Send the product, freight prepaid, to the indicated service facility. We will make repairs and return the instrument, freight prepaid. Repaired products are warranted for the remainder of the original warranty period or 90 days, whichever first occurs.

Limitation of Warranty

The above warranties do not apply to products which have been repaired or modified without New Focus's written approval, or products subjected to unusual physical, thermal or electrical stress; improper installation; misuse; abuse; accident or negligence in use, storage, transportation or handling. This warranty also does not apply to fuses, batteries, or damage from battery leakage.

This warranty is in lieu of all other warranties, expressed or implied, including any implied warranty of merchantability or fitness for a particular use. New Focus shall not be liable for any indirect, special, or consequential damages resulting from the purchase or use of its products.

First printing 2014

© 2014 by New Focus, Santa Clara, CA. All rights reserved. No part of this manual may be reproduced or copied without the prior written approval of New Focus.

This manual has been provided for information only and product specifications are subject to change without notice. Any changes will be reflected in future printings.

New Focus
3635 Peterson Way
Santa Clara, CA, 95054
USA
Part No. 90068136 Rev A

Confidentiality & Proprietary Rights

Reservation of Title

The New Focus Programs and all materials furnished or produced in connection with them ("Related Materials") contain trade secrets of New Focus and are for use only in the manner expressly permitted. New Focus claims and reserves all rights and benefits afforded under law in the Programs provided by New Focus.

New Focus shall retain full ownership of Intellectual Property Rights in and to all development, process, align or assembly technologies developed and other derivative work that may be developed by New Focus. Customer shall not challenge, or cause any third party to challenge the rights of New Focus.

Preservation of Secrecy and Confidentiality and Restrictions to Access

Customer shall protect the New Focus Programs and Related Materials as trade secrets of New Focus, and shall devote its best efforts to ensure that all its personnel protect the New Focus Programs as trade secrets of New Focus. Customer shall not at any time disclose New Focus's trade secrets to any other person, firm, organization, or employee that does not need (consistent with Customer's right of use hereunder) to obtain access to the New Focus Programs and Related Materials. These restrictions shall not apply to information (1) generally known to the public or obtainable from public sources; (2) readily apparent from the keyboard operations, visual display, or output reports of the Programs; (3) previously in the possession of Customer or subsequently developed or acquired without reliance on the New Focus Programs; or (4) approved by New Focus for release without restriction.

Trademarks

The New Focus logo and name are registered trademarks of Newport Corporation in Mexico, Israel, Singapore, the European Union, Taiwan, Hong Kong, China, Japan, Korea, Canada, Australia, and the United States.

Contents

Declaration of Conformity	1
Warranty	2
Limitation of Warranty	2
Confidentiality & Proprietary Rights	3
Contents	4
Figures.....	7
1 Safety Precautions	8
1.1 Definitions and Symbols.....	8
1.1.1 General Warning or Caution.....	8
1.1.2 Electrical Shock	8
1.1.3 European Union CE Mark	9
1.1.4 On.....	9
1.1.5 Off.....	9
1.1.6 Waste Electrical and Electronic Equipment (WEEE).....	9
1.1.7 Control of Hazardous Substances	10
1.2 Warnings and Cautions.....	10
1.2.1 General Warnings	10
1.2.2 General Cautions.....	10
1.3 Location of Labels and Warnings.....	12
1.3.1 Model 3502 Optical Chopper Controller Rear Panel.....	12
2 General Information	13
2.1 System Overview	13
2.1.1 Key Product Features:.....	13
2.2 Scope of this Manual	13
2.3 Unpacking and Inspection	14
2.3.1 What is included	14
2.4 Environmental Operation Requirement	15
2.4.1 Operating Limits	15
2.4.2 Weight and Dimensions.....	15

3	Using the Chopper	16
3.1	How the Model 3502 Optical Chopper Works	16
3.2	Mounting the Unit.....	17
3.2.1	Chopper Head	17
3.2.2	Chopper Motor.....	19
3.2.3	Mounting a Wheel.....	19
3.2.4	Mounting the Wheel Cover.....	21
3.3	Rack Mount Option	22
3.4	Initial Setup.....	22
3.4.1	Power	23
3.4.2	Connecting the Chopper Head to the Chopper Controller.....	23
3.4.3	Connecting the Chopper Controller to a Computer via USB	23
3.5	Operation	23
3.5.1	Front Panel Operation.....	24
3.6	Back Panel Operation	30
4	Computer Interfacing	32
4.1	Introduction.....	32
4.2	Using the Graphical User Interface (GUI).....	32
4.2.1	A Quick Start: How to Use the ‘New Focus Chopper Application’	33
4.3	USB Communication.....	34
4.4	Command Index and Conventions.....	34
4.5	Command Description	36
5	Troubleshooting	43
5.1	Normal Startup Operation.....	43
5.2	Symptoms and Steps to Follow	43
6	Specifications	45
6.1	Chopping Frequency.....	45
6.2	Internal Synthesizer	45
6.3	Reference Input.....	45
6.4	Reference Output	46
6.5	Phase Shifter	46

6.6	Harmonic Locking	46
6.7	External Voltage Control	46
6.8	General	46

7 Maintenance and Service 47

7.1	Enclosure Cleaning	47
7.2	Technical Support	47
7.3	Technical Support Contacts	47
7.4	Service	48
7.5	Warranty	48

Figures

Figure 1: Exclamation symbol.....	8
Figure 2: Electrical Shock symbol.....	8
Figure 3: CE mark.....	9
Figure 4: ON symbol.....	9
Figure 5: OFF symbol.....	9
Figure 6: WEEE Directive symbol.....	9
Figure 7: RoHS Compliant symbol.....	10
Figure 8: Warning, Certification, and Information Label.....	12
Figure 9: Functional block diagram for Model 3502 Optical Chopper.....	17
Figure 10: Model 3502 Optical Chopper Head with wheel cover installed. ...	18
Figure 11: Dimensions of Model 3502 Optical Chopper Head.....	19
Figure 12: Chopper wheels.....	20
Figure 13: Rack Mount Kit for Model 3502 Optical Chopper.....	22
Figure 14: Model 3502 Optical Chopper Controller front panel.....	24
Figure 15: Model 3502 Optical Chopper Controller back panel.....	30
Figure 16: Model 3502 Optical Chopper Application window.....	33

1 Safety Precautions

1.1 Definitions and Symbols

The following terms and symbols are used in this manual.

1.1.1 General Warning or Caution



Figure 1: Exclamation symbol.

The Exclamation symbol in the figure above appears in Warning and Caution tables throughout this manual. This symbol indicates that you should read the associated documentation to determine the nature of any potential hazards and any actions that should be taken against these hazards.

1.1.2 Electrical Shock



Figure 2: Electrical Shock symbol.

The Electrical Shock symbol in the figure above appears throughout this manual. It indicates a hazard arising from dangerous voltage. Any mishandling could result in irreparable damage to the equipment, and personal injury or death.

1.1.3 European Union CE Mark



Figure 3: CE mark.

The presence of the CE Mark on New Focus equipment means that this instrument has been designed, tested and certified compliant to all applicable European Union (CE) regulations and recommendations.

1.1.4 On



Figure 4: ON symbol.

The symbol in the figure above represents a power switch position on the Model 3502 Optical Chopper Controller. This symbol represents a *Power On* condition.

1.1.5 Off



Figure 5: OFF symbol.

The symbol in the figure above represents a power switch position on the Model 3502 Optical Chopper Controller. This symbol represents a *Power Off* condition.

1.1.6 Waste Electrical and Electronic Equipment (WEEE)



Figure 6: WEEE Directive symbol.

This symbol on the product or its packaging indicates that the product must not be disposed with regular waste. It is the user's responsibility to dispose of waste equipment marked with the WEEE Directive Symbol according to local laws. The separate collection and recycling of WEEE waste at the time of disposal will help conserve natural resources and ensure that it is recycled or disposed of

in a manner that protects human health and the environment. For information about where the user can drop off WEEE waste for recycling, please contact your local New Focus representative.

1.1.7 Control of Hazardous Substances



Figure 7: RoHS Compliant symbol.

This label indicates product compliance with the EU Directive 2002/95/EC that restricts the content of six particular hazardous substances.

1.2 Warnings and Cautions

1.2.1 General Warnings

Observe these general warnings when operating or servicing this equipment:

- Thoroughly read and understand this User's Manual.
- Heed all warnings on the unit and in the operating instructions.
- Use this equipment indoors only.
- The external input power to this equipment can be up to 240 VAC. Please follow this User's Manual for proper use or installation of this instrument.
- Disconnect power before cleaning the equipment. Do not use liquid or aerosol cleaners; use only a damp lint-free cloth.
- Lockout all electrical power sources before servicing the equipment.
- There are no user-replaceable fuses in this equipment. The user must ensure that appropriate current-limiting protection is provided by the external AC power line.
- Do not operate this equipment in an explosive or flammable atmosphere.
- Use only the New Focus-supplied mains power cord with the external AC supply. Use of under-rated power cords may cause property damage.

1.2.2 General Cautions

Observe these cautions when operating this equipment:

- Thoroughly read and understand this User's Manual.

- If this equipment is used in a manner not specified in this manual, the protection provided by this equipment may be impaired.
- Do not block ventilation openings.
- Use only the specified replacement parts.
- Follow precautions for static sensitive devices when handling this equipment.
- This product should only be powered as described in the manual.
- There are no user-serviceable parts inside the Model 3502 Optical Chopper Controller or motor head.

	<p style="text-align: center;">WARNING</p> <p>If this equipment is used in a manner not specified in this manual, the protection provided by this equipment may be impaired.</p>
---	---

	<p style="text-align: center;">WARNING</p> <p>This instrument is intended for use by qualified personnel who recognize thermal, shock, or laser hazards and are familiar with safety precautions required to avoid possible injury. Read this User's Manual thoroughly before attempting to use the Model 3502 Optical Chopper!</p>
---	--

	<p style="text-align: center;">CAUTION</p> <p>The Model 3502 Optical Chopper is designed to be safe when operated under Normal Environmental Conditions as defined in EN61010-1:2010. Operation under harsher environmental conditions can result in severe injury.</p>
---	--

	<p>The Model 3502 Optical Chopper is intended for use in an industrial laboratory environment. Use of this product in other environments, such as residential, may result in electromagnetic compatibility difficulties due to conducted as well as radiated disturbances.</p>
---	--

1.3 Location of Labels and Warnings

1.3.1 Model 3502 Optical Chopper Controller Rear Panel



Figure 8: Warning, Certification, and Information Label.

2 General Information

2.1 System Overview

The Model 3502 Optical Chopper is used to introduce a periodic interruption of a light path in an optical experiment resulting in an amplitude modulation, which is useful for many small optical signal detection schemes. The modulation frequency can be controlled from 4 Hz to 10.65 kHz. Full control is available through the Model 3502 Optical Chopper Controller's front panel. In addition, the Chopper Controller can be programmed over a USB communication interface to set and measure the modulation frequency, adjust the interruption phase, and perform all other operations available through the front panel.

2.1.1 Key Product Features:

A number of advanced features make the Model 3502 Optical Chopper an excellent choice for many applications:

- Extremely low jitter noise across entire range of chopping frequencies
- Windows-based graphical user interface (GUI)
- User-written software control
- LabVIEW™ and C# examples

2.2 Scope of this Manual

Carefully read this User's Manual before using the 3502 Optical Chopper. Be especially careful to observe the warnings and cautions throughout this manual. If any operating instructions are not clear, please contact New Focus.

This instruction manual contains the necessary information for operation and maintenance of the Model 3502 Optical Chopper, as well as information for troubleshooting and obtaining service if necessary.

2.3 Unpacking and Inspection



WARNING

Do not attempt to operate this equipment if there is evidence of shipping damage or you suspect the unit is damaged. Damaged equipment may present additional hazards to you. Contact New Focus technical support for advice before attempting to plug in and operate damaged equipment.

The Model 3502 Optical Chopper is carefully assembled, tested, and inspected before shipment. Upon receiving this instrument, check for any obvious signs of physical damage that might have occurred during shipment. Report any such damage to the shipping agent immediately.

NOTE: Retain original packing materials in case reshipment becomes necessary.

2.3.1 What is included

The 3502 package contents:

- Model 3502 Optical Chopper Controller.
- Model 3502 Motor Assembly (including wheel cover) with a shielded Ethernet cable and a set of 2-slot, 7/5-slot, 42/30-slot, 60-slot, 60/2-slot, and 100-slot wheels, and lab post mounting hardware.
- USB Flash Drive which contains this User Manual, USB driver, GUI software application and documented programming examples.
- Power supply cables (North American and European).

2.4 Environmental Operation Requirement

2.4.1 Operating Limits

Parameter	Minimum	Maximum
Voltage Requirements	100V/50-60Hz	240V/50-60Hz
Electrical Ratings		25 Watts 100-240 VAC 50-60 Hz
Operating temperature	10 °C (≤ 90% humidity, non-condensing)	40 °C (≤ 90 % humidity, non-condensing)
Storage temperature	0 °C (≤ 85% humidity, non-condensing)	50 °C (≤ 85 % humidity, non-condensing)
Relative Humidity (storage)		≤ 85%
Altitude		< 3000 meters (10000 feet)
Environment, Use		Indoor Use Only
Pollution Degree		2

*Operating outside the operating limits may damage the unit.

2.4.2 Weight and Dimensions

Net Weight	5.7 lb. (Chopper Head assembly included)
Controller Dimensions	4.0 in x 8.5 in x 11.0 in (H x W x L)

3 Using the Chopper

3.1 How the Model 3502 Optical Chopper Works

The Model 3502 Optical Chopper is designed to interrupt light paths in optical experiments at frequencies from 4 Hz to 10.65 kHz. Both single- and dual-beam experiments can be performed across a broad range of chopping frequencies. The Chopper has a crystal-controlled frequency synthesizer that serves as an internal reference frequency for locking the Chopper to a particular chopping frequency. Reference frequencies can also be provided through the Sync In BNC connection to allow the Chopper to lock to an external source.

Several measures ensure that jitter and drift of the chopping frequency is reduced to a minimum. Precision photo-etched wheels are mounted on a high quality DC motor. The Model 3502 Optical Chopper Head has a photo-sensor for monitoring the chopping frequency of the outer part of the wheel. The Chopper Controller then actively stabilizes the motor speed to match the desired chopping frequency. This technique minimizes phase noise at the chopping frequency and provides for long-term stable chopping with minimal frequency drift.

Figure 9 shows a block diagram of the Model 3502 Optical Chopper system. Programmable divide/multiply circuitry allows for harmonic or subharmonic locking of the Chopper to the reference frequency. In addition, the phase of the chopping frequency may be varied over a -180 to +179 degree range with respect to the reference frequency. A variety of TTL-level outputs are available for use in triggering lock-in amplifiers, oscilloscopes, photon counters, or boxcar averagers.

The chopping frequency, as well as a number of other operating parameters, can be viewed on the front panel display. Easy-to-use cursor keys provide easy adjustment of operating parameters. From the front panel the user can store and recall up to nine instrument setups. A USB 2.0 interface provides remote operation of all instrument functions.

The Chopper Head can be mounted on a 1/2"-diameter post or bolted directly to a standard optical bench. The Model 3502 Optical Chopper is supplied with six Chopper wheels and a wheel cover. The Model 3510 Rack Mount Kit, sold separately, enables the Chopper Controller to be mounted in a rack.

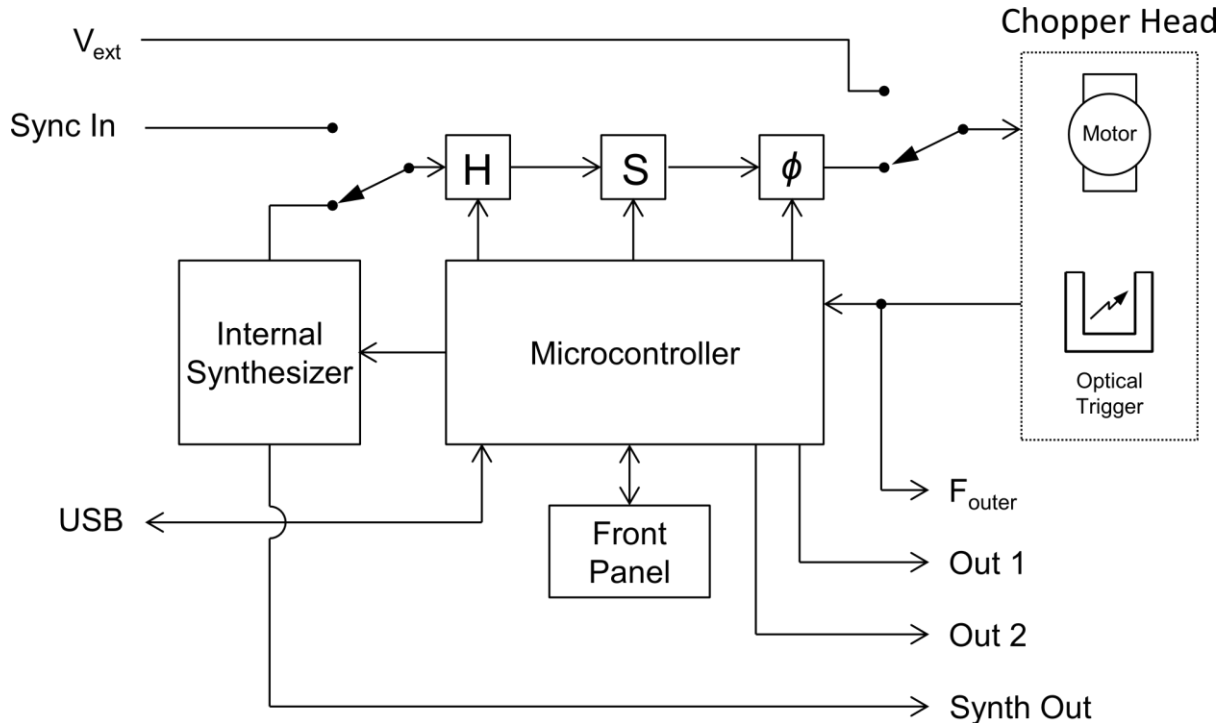

Figure 9: Functional block diagram for Model 3502 Optical Chopper.

3.2 Mounting the Unit

3.2.1 Chopper Head

The Model 3502 Optical Chopper Head (Figure 10 and Figure 11) may be secured to standard optical benches using $\frac{1}{4}$ "-20 or M6 bolts. The bolts pass through the mounting plate perpendicular to the plane of the optical bench. This mounting method provides the advantage of allowing the wheel to be rotated by loosening the $\frac{1}{4}$ "-20 set screws on the side of the motor mount. Do not over-tighten the set screws.

The Model 3502 Optical Chopper head may also be mounted on standard $\frac{1}{2}$ " optical bench rods. First, loosen the two $\frac{1}{4}$ "-20 set screws. (These secure the head to the mounting plate by compressing on the dowel.) Remove the dowel and mounting plate assembly. Insert the $\frac{1}{4}$ "-20 knob (supplied with the Chopper) into the base of the head. This knob is inserted into the same hole occupied by the dowel. Slide the motor mount onto the $\frac{1}{2}$ " optical bench rod and hand-tighten the knob. Do not over-tighten.

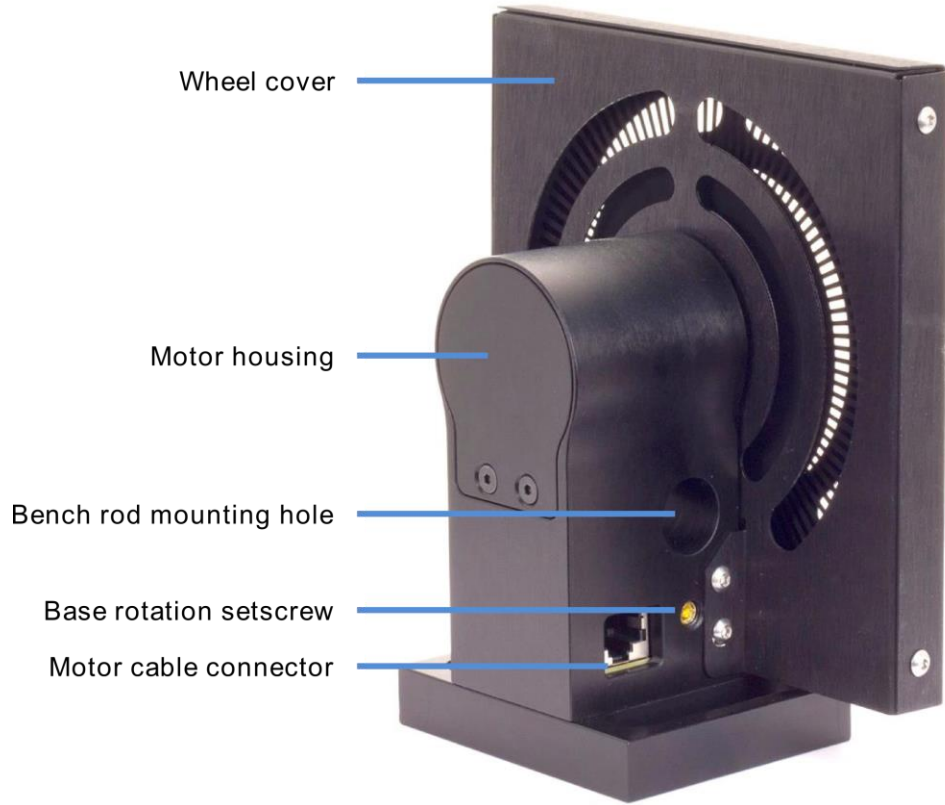

Figure 10: Model 3502 Optical Chopper Head with wheel cover installed.

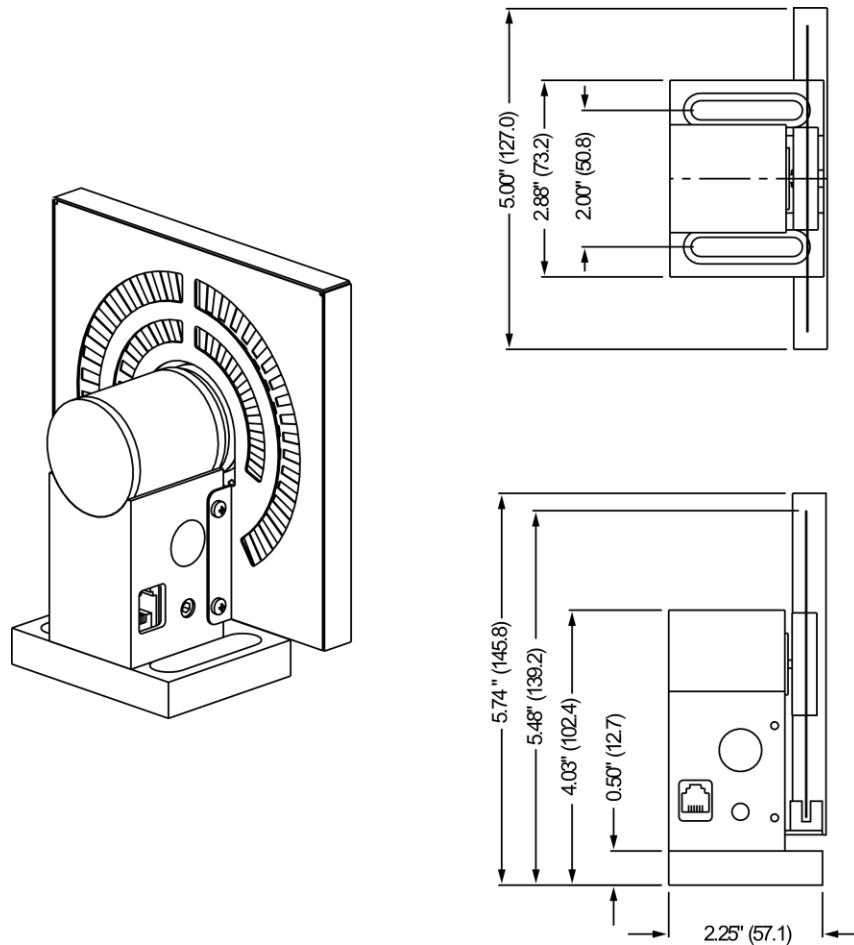

Figure 11: Dimensions of Model 3502 Optical Chopper Head. Dimensions in inches (mm).

3.2.2 Chopper Motor

The operating life of the Chopper motor is limited. Long-term use of the motor at high speed will result in faster wear and a shorter lifetime. Contact New Focus for details about replacing the motor, if this becomes necessary.

3.2.3 Mounting a Wheel

Six wheels are shipped with Model 3502 Optical Chopper, shown in Figure 12 below. To install or change a wheel first power off the Chopper Controller. Secure the chopping head to a work surface. Remove the four 4-40 screws that secure the retaining cap over the wheel, while taking care not to bend the wheel on the optical pickup. Install the replacement wheel, retaining cap, and 4-40 screws. Do not over-tighten the screws. Please note that if a wheel is bent during the installation/removal process, it can be very difficult to straighten again. This may degrade the stability of operation of the Model 3502 Optical Chopper system, and a replacement wheel may be required.

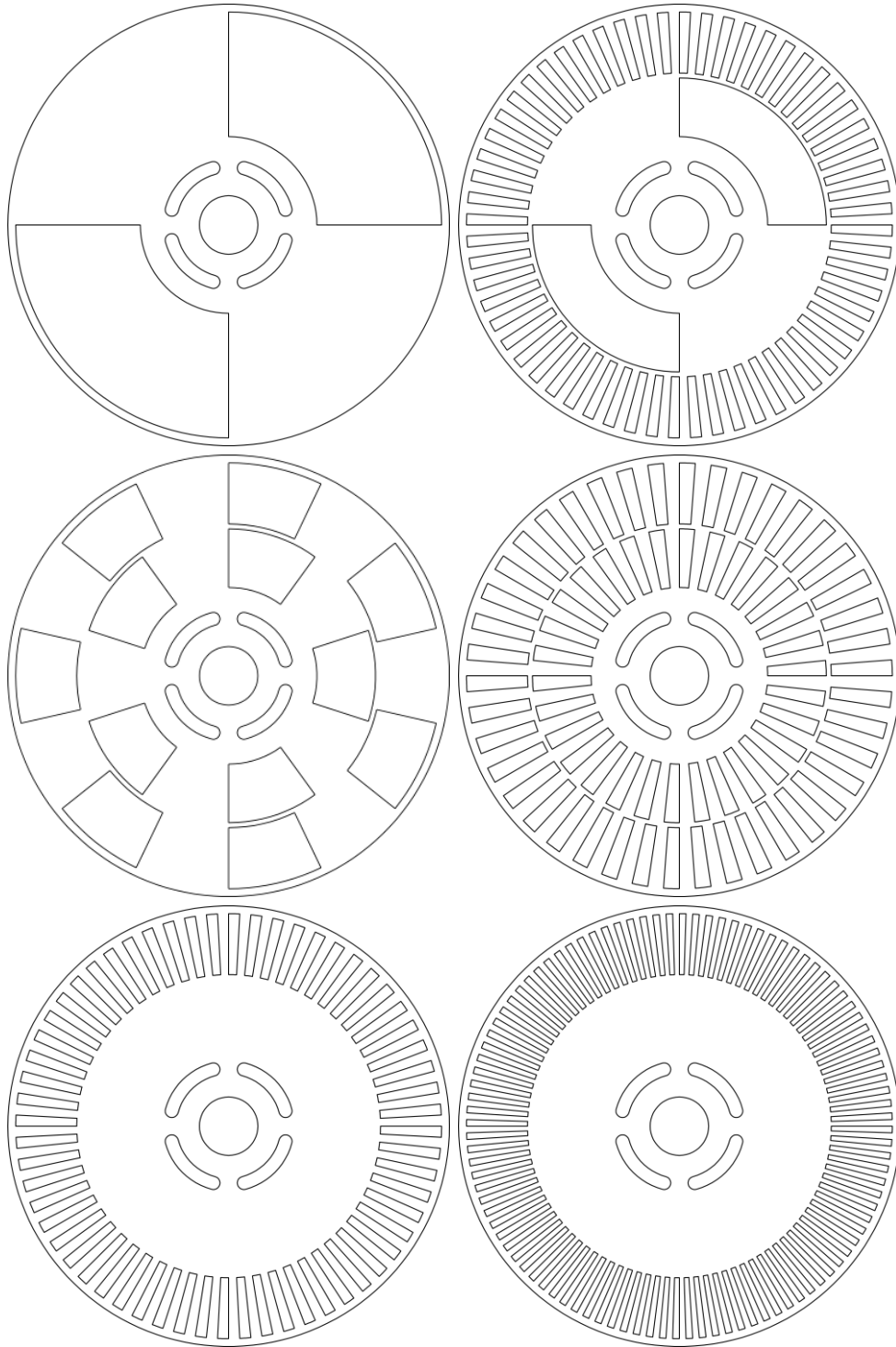



Figure 12: Chopper wheels. Top row: 2-slot and 60/2-slot wheels. Middle row: 7/5-slot and 42/30-slot wheels. Bottom row: 60-slot and 100-slot wheels. All wheels are 4.50" (114.3 mm) O.D.

	<p>WARNING</p> <p>The moving wheel may inflict injury. The operator should ensure the safety of personnel who may be exposed to this hazard.</p>
---	---

3.2.4 Mounting the Wheel Cover

	<p>WARNING</p> <p>The wheel cover is provided for safety and its installation is encouraged. The Chopper wheel can cause injury if it is touched while rotating. This is especially critical if you find yourself reaching into your optical set-up with the lights off. You may want to use the Chopper wheel cover to reduce the chance of injury.</p>
---	---

The wheel cover attaches to the Chopper Head with four screws. The wheel cover is made of 0.031" (0.80 mm) aluminum with an anti-reflective black anodized coating. Two concentric slots, etched in both faces of the cover, allow apertures of various sizes according to the table below. The wheel cover dimensions are 5" x 5" x 0.5".

Wheel Type	Largest Beam Diameter	
	Inner Cover Slot	Outer Cover Slot
2-slot	0.295" (7.50 mm)	0.394" (10.00 mm)
60/2-slot	0.295" (7.50 mm)	0.107" (2.71 mm)
7/5-slot	0.295" (7.50 mm)	0.394" (10.00 mm)
42/30-slot	0.135" (3.44 mm)	0.138" (3.51 mm)
60-slot	-	0.107" (2.71 mm)
100-slot	-	0.064" (1.62 mm)

The wheel cover is also provided to reduce the generation of stray light that could interfere with your measurements. The Chopper head uses an IR sensor to detect Chopper wheel motion. The source in this sensor emits light of approximate wavelength 950 nm. The wheel cover will greatly reduce the amount of sensor-radiated stray IR light picked up by your experiment detector.

To install the wheel cover, first install a wheel on the Chopper hub. Then, slide the wheel cover over the wheel. Please note that it can require some force to separate the wheel cover's mounting flanges far enough to fit over the motor housing. Once the mounting flanges are lowered past the motor, align one of the four flange holes with a threaded hole in the motor base and loosely attach the cover to the base with one of the 4-40 x 3/8" mounting screws. Loosely fasten the three remaining screws. Tighten the four screws after they are installed.

3.3 Rack Mount Option

The Model 3510 Rack Mount Kit is a Chopper accessory that allows one or two Chopper Controllers to be mounted in a standard rack. The kit consists of two short ears, one long ear, one rack plate, and six 6-32 flathead screws. The figure below illustrates how to use the rack mount kit to mount a single Chopper Controller or two Chopper Controllers side-by-side.

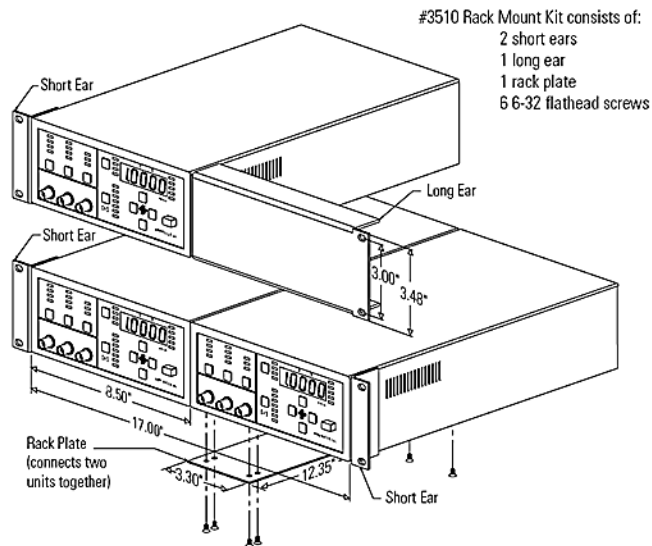



Figure 13: Rack Mount Kit for Model 3502 Optical Chopper

3.4 Initial Setup

	<p>WARNING</p> <p>The Model 3502 Optical Chopper Controller is intended for use ONLY with New Focus Model 3502 Optical Chopper motor heads. Connection of other devices to the unit's motor connectors may cause damage to the unit or the connected device, fire, and/or personal injury.</p>
---	--

	<p>WARNING</p> <p>Before operating the Model 3502 Optical Chopper Controller, thoroughly read and understand this User's Manual!</p>
---	---

This section contains information on how to connect Model 3502 Optical Chopper Controller to your local mains power and how to connect the Chopper Head to the Chopper Controller.

3.4.1 Power

Make sure that that power switch is in the OFF position. Connect the male end of the provided AC power cable to the mains supply. Connect the female end to the three-pronged input receptacle on the back of the Chopper Controller.

	<p>WARNING</p> <p>To avoid electric shock, connect the instrument to building earth-ground, 3-prong receptacles by using the supplied power cord only. Failure to observe this precaution can result in damage to the product, fire, severe injury, or death.</p>
---	--

	<p>WARNING</p> <p>Do not position this product in such a manner that would make it difficult to disconnect the power cord.</p>
---	---

	<p>WARNING</p> <p>Position the equipment so that access to the mains ON/OFF switch is readily available. In the event of a hazard, press the grey Power switch on the lower right of the front panel to the OFF position to turn power OFF to the internal electronics and fully disconnect the power cord of the Controller from mains power.</p>
---	---

3.4.2 Connecting the Chopper Head to the Chopper Controller

Make sure that the power switch is in the OFF position. Connect the Chopper Head to the Controller with the provided standard shielded Ethernet cable by plugging the smaller modular connector of the cable into the Chopper Head and the larger connector into the MOTOR input on the rear panel of the Chopper Controller.

3.4.3 Connecting the Chopper Controller to a Computer via USB

The Model 3502 Optical Chopper Controller can be connected to a computer with a standard USB-A to USB-B cable for computer control and communication.

3.5 Operation

When the unit is turned on the unit performs a series of internal verifications, the word PASS is briefly displayed on the 5-digit LED numeric display, and it shows its driving frequency setpoint. The unit is then ready to operate the Chopper Head.

3.5.1 Front Panel Operation

The Model 3502 Optical Chopper can be operated manually by keying in control functions from the Chopper Controller front panel shown below.

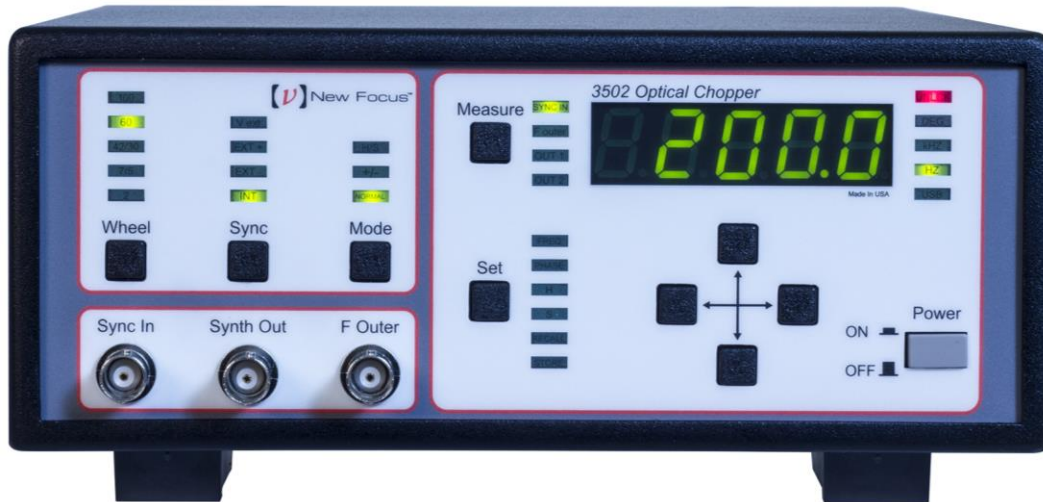

Figure 14: Model 3502 Optical Chopper Controller front panel.

Wheel Button

The User may select from different wheels to accommodate the chopping frequency of interest. Single- or double-slot wheels are provided for single- or dual-path experiments. The table below summarizes the provided wheel selection and each wheel's chopping frequency range.

Wheel Type (slots)	Lowest Frequency (F_{outer})	Highest Frequency (F_{outer})
100	200 Hz	10.65 kHz
60	120 Hz	6.40 kHz
42/30	84 Hz	4.48 kHz
7/5	14 Hz	746 Hz
2	4 Hz	213 Hz
60/2	See text	See text

F_{outer} is the chopping frequency as measured by an optical pick-up on the Model 3502 Optical Chopper Head. If a wheel has two sets of slots, F_{outer} refers to the chopping frequency of the slots on the outer edge of the wheel. To change the wheel type, push the Wheel button until the LED lights under the desired wheel type.

For setups requiring very low chopping frequencies and high stability the 60/2-slot wheel may be used. There is no wheel setting for this particular wheel on the front panel—the 60-slot wheel setting must be selected. The actual chopping frequency will differ from that displayed on the front panel by a factor of $2/60 = 1/30$. For example, in NORMAL mode with the internal synthesizer set to 120 Hz and with the 60-slot wheel setting selected, the actual chopping frequency through the 2-slot segment of the wheel will be $(1/30) \cdot 120 = 4$ Hz.

Sync Button

The user may synchronize the chopping frequency to the Chopper's internal synthesizer (INT), the rising edge (EXT+) or falling edge (EXT-) of an externally-supplied signal on Sync In. The motor's rotational speed may be controlled directly by applying a negative voltage to the V_{ext} input.

When INT is selected, the signals available on the OUT 1 and OUT 2 outputs (see the following section on the Mode button) on the back panel are phase-locked to the internal synthesizer. When using the INT setting, a signal applied to Sync In has no effect on the device's operation.

When an external signal is used, either with EXT+ or EXT-, the signals available on the OUT 1 and OUT 2 outputs are instead phase-locked to the external signal. In EXT+ and EXT- modes the output from Synth Out (described below) is not locked to, and does not have the same frequency as, the external signal and remains at the frequency setpoint set on the front panel.

When V_{ext} is selected, the user may drive the motor directly with an analog voltage (-10 V to 0 V) applied at V_{ext} on the back panel. When using V_{ext} or INT, a signal applied to the Sync In input has no effect on the Chopper. In this setting, the signals available on OUT 1 and OUT 2 are frequency- and phase-locked to the chopping frequency measured using the photo-interrupt on the Chopper Head, F_{outer} . Note that these signals will therefore only be as stable as the externally-controlled chopping frequency.

To change the Sync source, press the Sync button until the LED under the desired Sync source lights.

Mode Button

The Mode button allows the User to change the frequency that F_{outer} will lock to in addition to the reference signals available at OUT 1 and OUT 2 (rear panel). The table below gives the locking frequency of F_{outer} and the reference signals available at OUT 1 and OUT 2, for each Mode setting.

In the table, the following definitions are used:

- F_{sync} : frequency of the Sync source
- F_{outer} : chopping frequency of outer slots as measured by IR sensor
- F_{inner} : chopping frequency of the inner slots; for single-slot wheels F_{outer} is the chopping frequency, and F_{inner} is undefined.

Mode Setting	F_{outer} locked to	OUT 1	OUT 2
H/S	$(H/S) \cdot F_{\text{sync}}$	$(H/S) \cdot F_{\text{sync}}$	$[H/(7 \cdot S)] \cdot F_{\text{sync}}$
+/-	F_{sync}	$F_{\text{outer}} - F_{\text{inner}}$	$F_{\text{outer}} + F_{\text{inner}}$
Normal	F_{sync}	$5 \cdot F_{\text{sync}}$	F_{inner}

Table 1: Chopping frequency and outputs vs. mode setting.

For all wheels with a dual slot pattern (except for the 60/2-slot wheel), $F_{\text{outer}} = 7/5 \cdot F_{\text{inner}}$. Therefore, $F_{\text{outer}} - F_{\text{inner}} = 2/7 \cdot F_{\text{sync}}$ and $F_{\text{outer}} + F_{\text{inner}} = 12/7 \cdot F_{\text{sync}}$.

When the Sync setting is V_{ext} , the reference signals available at OUT 1 and OUT 2 are generated with respect to the measured chopping signal F_{outer} .

Please see Table 2 on page 29 for a complete reference of output signals according to Mode selection.

To change the Mode, push the Mode key until the LED under the desired selection lights up.

Sync In

A TTL signal applied to the Sync In input will be used as a frequency and phase reference in EXT+ and EXT- modes. TTL pulses can be used to trigger the Chopper Controller as long as they are longer than 1 μs .

Synth Out

The signal provided by the internal synthesizer is available on this output.

F Outer

The signal from the optical pick-up on the Chopper Head is available on this output as a TTL signal.

Set Button

The Set button selects which instrument parameter you can modify using the cursor keys. Press Set until the LED lights under the desired parameter: FREQ, PHASE, H, S, RECALL, or STORE. Each of these parameters is described below.

The up arrow and down arrow keys will then change the parameter value. In some cases, the left arrow and right arrow keys select the significant digit to be modified.

Set: FREQ

The user may set the internal synthesizer frequency depending on the Sync source selected. When EXT-, EXT+ or V_{ext} sync has been selected, the frequency may range from 4.00 Hz to 99.9 kHz.

When the INT setting is selected for the Sync source, the synthesizer frequency will be restricted to the working range of the particular chopping wheel. In H/S mode this range will be modified by the user-specified values of H and S according to:

$$F_{\max} = (S/H) \cdot F_{\text{outer}}, \text{ highest,}$$

and

$$F_{\min} = (S/H) \cdot F_{\text{outer}}, \text{ lowest.}$$

The internal synthesizer frequency may be set to three significant digits. The significant digit to be modified may be selected by the left and right arrow keys. The magnitude of the digit may be changed with the up and down arrow keys. If the display overflows or underflows, the display will change between the Hz/kHz LEDs and move the decimal point to maintain three significant digits of resolution.

Set: PHASE

The phase delay may be set from -180.0° to $+179.0^\circ$. The phase shift is always with respect to F_{outer} . In NORMAL and +/- modes, $F_{\text{outer}} = F_{\text{sync}}$. In H/S mode $F_{\text{outer}} = (H/S) \cdot F_{\text{sync}}$.

When the phase adjustment is active, the DEG LED will be lit. The left and right arrow keys can be used to select the significant digit to modify, and this digit will blink. The up and down arrow keys can be used to change the magnitude of the digit.

Set: H and S

In H/S mode the user may lock the Chopper to a harmonic of the sync frequency. H is set to the harmonic of interest. Use the up arrow and down arrow keys to set H to an integer value from 1 to 15.

The user may lock the Chopper to a subharmonic of the sync frequency. S is set to the subharmonic of interest. Use the up arrow and down arrow keys to set S to an integer value from 1 to 15.

S and H may be set in any combination.

Set: STORE

The user may store an instrument setup in one of two ways. First, the control unit will retain the control settings when the power is removed. When power is restored, the instrument will recall the last control settings used.

Second, the user may utilize one of nine programmable instrument set-ups. To store an instrument setup press the Set button until STORE is lit. Then, use the up and down arrow keys to assign the instrument setup number, 1-9. Press the left or right arrow key to store the instrument's settings. Location 0 is reserved for the factory default settings (see the Default Settings section below).

Set: RECALL

The user may recall an instrument setup in one of two ways. Firstly, on power up, the instrument will recall the last control settings used.

Secondly, a previously stored setup can be recalled by pressing the Set button until the RECALL LED is lit. The up and down arrow keys are used to select the instrument setup number, again, ranging from 0 to 9. Press the left or right arrow key to recall the displayed instrument setup. The display will blink when the recall process is complete. Location 0 is reserved for the factory default settings.

Set: Default Settings

Location 0 is reserved for the factory default settings: Wheel is set to 42/30, Sync is set to INT, Mode is set to NORMAL, and the internal synthesizer frequency is set to 84 Hz.

Measure Button

The Measure button is used to select which frequency measurement (F_{sync} , F_{outer} , OUT 1 or OUT 2) is displayed on the front panel. The instrument will continue to measure and update the display until another function key is pressed. To change the parameter to be measured, press the Measure button until the LED lights under the desired parameter.

UNLCK LED

The red UNLCK LED indicates when the Chopper is not synchronized to an internal or external sync frequency. In addition, the UNLCK LED will blink when an external sync frequency exceeds the limits for a particular wheel.

USB LED

The USB LED lights when the Chopper Controller is connected to a computer.

Mode	Sync Source	OUT 1		OUT 2		F _{outer}	
		Output Freq.	Phase is locked to	Output Freq.	Phase is locked to	Output Freq.	Phase is locked to
Normal	Int	$5 \cdot (\text{Int. } F_{\text{sync}})$	Int. F_{sync}	$(5/7) \cdot (\text{Int. } F_{\text{sync}})$	Int. F_{sync}	Int. F_{sync}	Int. F_{sync}
	¹ Ext+, Ext-	$5 \cdot (\text{Ext. } F_{\text{sync}})$	Ext. F_{sync}	$(5/7) \cdot (\text{Ext. } F_{\text{sync}})$	Ext. F_{sync}	Ext. F_{sync}	Ext. F_{sync}
	V _{ext}	$5 \cdot (F_{\text{outer}})$	F_{outer}	$(5/7) \cdot (F_{\text{outer}})$	F_{outer}	<i>Freq. is controlled by ext. voltage.</i>	<i>Motor phase is not controlled internally.</i>
+/-	Int	$(2/7) \cdot (\text{Int. } F_{\text{sync}})$ <i>i.e. $F_{\text{outer}} - F_{\text{inner}}$ with $F_{\text{outer}} = (7/5) \cdot F_{\text{inner}}$</i>	Int. F_{sync}	$(12/7) \cdot (\text{Int. } F_{\text{sync}})$ <i>i.e. $F_{\text{outer}} + F_{\text{inner}}$ with $F_{\text{outer}} = (7/5) \cdot F_{\text{inner}}$</i>	Int. F_{sync}	Int. F_{sync}	Int. F_{sync}
	¹ Ext+, Ext-	$(2/7) \cdot (\text{Ext. } F_{\text{sync}})$ <i>i.e. $F_{\text{outer}} - F_{\text{inner}}$ with $F_{\text{outer}} = (7/5) \cdot F_{\text{inner}}$</i>	Ext. F_{sync}	$(12/7) \cdot (\text{Ext. } F_{\text{sync}})$ <i>i.e. $F_{\text{outer}} + F_{\text{inner}}$ with $F_{\text{outer}} = (7/5) \cdot F_{\text{inner}}$</i>	Ext. F_{sync}	Ext. F_{sync}	Ext. F_{sync}
	V _{ext}	$(2/7) \cdot (F_{\text{outer}})$	F_{outer}	$(12/7) \cdot (F_{\text{outer}})$	F_{outer}	<i>Freq. is controlled by ext. voltage.</i>	<i>Motor phase is not controlled internally.</i>
H/S	Int	$(H/S) \cdot (\text{Int. } F_{\text{sync}})$	Int. F_{sync}	$(H/7S) \cdot (\text{Int. } F_{\text{sync}})$	Int. F_{sync}	$(H/S) \cdot (\text{Int. } F_{\text{sync}})$	Int. F_{sync}
	¹ Ext+, Ext-	$(H/S) \cdot (\text{Ext. } F_{\text{sync}})$	Ext. F_{sync}	$(H/7S) \cdot (\text{Ext. } F_{\text{sync}})$	Ext. F_{sync}	$(H/S) \cdot (\text{Ext. } F_{\text{sync}})$	Ext. F_{sync}
	V _{ext}	$(H/S) \cdot (F_{\text{outer}})$	F_{outer}	$(H/7S) \cdot (F_{\text{outer}})$	F_{outer}	<i>Freq. is controlled by external voltage.</i>	<i>Motor phase is not controlled internally.</i>

Table 2: Summary of Modes, Settings and Outputs.

3.6 Back Panel Operation

The back panel of 3502 Optical Chopper Controller provides the functions operation described below.

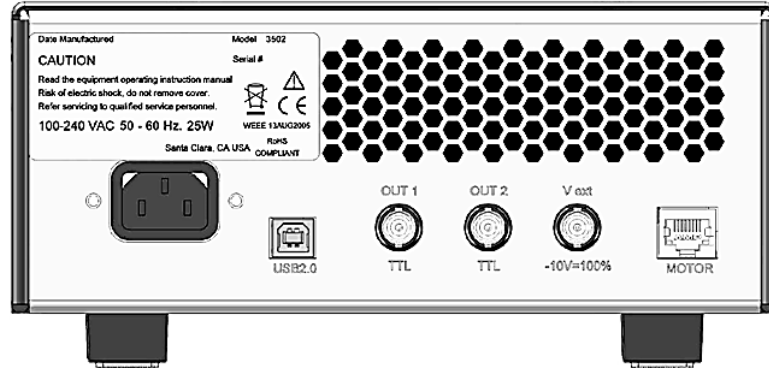



Figure 15: Model 3502 Optical Chopper Controller back panel.

	<p>CAUTION</p> <p>Do not block the rear panel of the Controller. Ensure a minimum clearance of 30" for adequate ventilation of the device. Blocking the normal convective airflow around the unit, or thermally insulating the unit, can result in severe injury, damage to the product, and/or fire.</p>
--	--

OUT 1

The function of the OUT 1 output depends on the instrument's operating mode. In H/S mode, the instrument provides a TTL-level signal at frequency $(H/S) \cdot F_{\text{sync}}$. In +/- mode the frequency at OUT 1 is $F_{\text{outer}} - F_{\text{inner}}$, and in NORMAL mode the frequency is $5 \cdot F_{\text{outer}}$. This information is also summarized in Table 2 on page 29.

OUT 2

The function of the OUT 2 output depends on the instrument's operating mode. In H/S mode, the instrument provides the user with a TTL-level signal at frequency $[H/(7 \cdot S)] \cdot F_{\text{sync}}$. In +/- mode the frequency at OUT 2 is $F_{\text{outer}} + F_{\text{inner}}$. In NORMAL mode the frequency is F_{inner} . This information is also summarized in Table 2 on page 29.

V_{ext}

The V_{ext} BNC input connector can be used to supply an external 0 to -10 V DC voltage. When the Sync setting is V_{ext} , the user may drive the Chopper motor directly with this input DC voltage. In this case, 0 to -10 V DC corresponds to 0 to 100% of the highest motor speed, respectively.

MOTOR socket

The input marked MOTOR on the rear panel is used to connect the 3502 Optical Chopper Head to the Chopper Controller with the shielded Ethernet cable provided.

USB 2.0

The USB-B input port is used in connecting the Chopper Controller to a host computer system. This allows the instrument to be controlled remotely via USB interface.

Power Entry Module

The AC power is connected at the power entry module on the rear panel. The power module has been chosen for global operation, and North American and European power cords are supplied.

Motor Cable

The cable that connects the Chopper Controller to the Chopper Head is a six-conductor shielded Ethernet cable. Connect the cable from the connector on the side of the Chopper Head to the MOTOR connector on the back panel of the Chopper Controller. The instrument has been tested with cable lengths up to 25 feet, but the Chopper is supplied with a shorter cable.

4 Computer Interfacing

4.1 Introduction

The Model 3502 Optical Chopper can be controlled remotely over the USB 2.0 interface either via an intuitive, Windows-based Graphical User Interface (GUI) application or via commands sent from a host PC.

Before connecting the instrument to the USB interface the user should install the application included on the flash drive that accompanies the Model 3502 Optical Chopper. The installer will install not only the GUI application, but also the appropriate USB drivers and programming examples (LabVIEW and C#), and supporting documentation. Please consult the ‘Readme Chopper Application.pdf’ document on the flash drive for installation instructions and a list of the files that are installed. This document also addresses important considerations when installing the software on 32-bit or 64-bit operating systems.

Although the user can choose a custom installation directory, the default location is under ‘Program Files\New Focus\New Focus Chopper Application\’. Three sub-directories are installed here: ‘Bin’, containing the New Focus Chopper Application and supporting files; ‘Docs’, containing documentation of the GUI Application, the programming examples and the Newport USB library API documentation; and ‘Samples’, containing C# and LabVIEW examples to get you started with remote operation of the Model 3502 Optical Chopper. Please note that these examples are provided for reference only.

The latest GUI application version and supporting files can always be found on the Model 3502 Optical Chopper’s product page at newport.com.

4.2 Using the Graphical User Interface (GUI)

The GUI allows full control of the Model 3502 Optical Chopper’s front panel functions (save for turning the Controller On/Off). Below is a screenshot of the ‘3502 Optical Chopper Application’ GUI window.

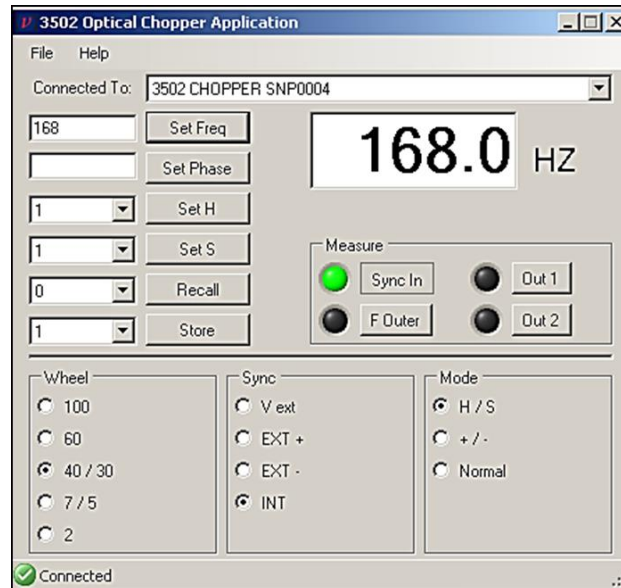



Figure 16: Model 3502 Optical Chopper Application window.

4.2.1 A Quick Start: How to Use the ‘New Focus Chopper Application’

1. Turn the Model 3502 Optical Chopper Controller on using the power button on the front panel of the Controller.
2. Open the New Focus Chopper Application. If you turn on the Chopper after opening the application you may need to select the Connect menu item from the File menu.
3. The  icon at the lower left corner of the window indicates that the GUI has successfully established a connection to the Chopper Controller.
4. Operating parameters can now be set from the application window: radio buttons are used to select the Wheel, Sync mode, and Mode of operation.
5. The desired chopping frequency is set by entering the value in Hz in the topmost text entry field and pressing the Set Freq button. Similarly, the chopping phase, H, and S can all be changed. Note that although you can set values for the chopping frequency, phase, H, and S via the GUI, the present values of these setpoints can only be read through the front panel of the Chopper Controller.
6. Up to nine setup states can be stored using the Store button on the left. This is done by first assigning the setup state a number (1-9) from the dropdown menu next to the Store button, then clicking the button. Similarly, a setup state can be recalled using the Recall button.
7. The frequency of Sync In, F_{outer} , OUT 1, and OUT 2 can be measured by clicking their respective button in the Measure field. The magnitude of the frequency measured (in Hz) will be shown in the numeric display field.
8. To exit the application, either close the window or select ‘Exit’ from the ‘File’ menu.

4.3 USB Communication

To control the Model 3502 Optical Chopper remotely without using the GUI application, commands can be issued directly over USB using the Newport USB library. The API is described in detail in the document ‘Chopper USB Libraries API User’s Manual.pdf’. This file is installed in the ‘Docs’ folder. After consulting this document, the best way to become acquainted with the procedure for controlling the Model 3502 Optical Chopper programmatically is to review the provided C# and LabVIEW examples.

4.4 Command Index and Conventions

In the brief command index below and detailed command descriptions that follow in the next subsection several conventions are used.

Some commands may be used to set and query an operating parameter. For example, the PHS command can be used to set the chopping phase (PHS900) or to read the value of the phase (PHS?). If a command allows querying, it will be followed by a ‘?’. If a command is not a query, there will be no response from the Chopper Controller.

A bracket pair ‘[]’ indicates that the command accepts a data value. Data ranges are given in parentheses ‘()’. Do not use a decimal point or comma in data passed to the Chopper Controller this way. For example, to set the chopping frequency to 1.23 kHz, send the command OSC123000. To set the phase to -90 degrees, send the command PHS-90. Note that data returned from the Controller will have decimal points included.

Multiple commands on a single line must be separated by a semicolon ‘;’.

Table 3 below summarizes all commands.

FR*?	Measures a given frequency. $1 = F_{\text{sync}}, 2 = F_{\text{outer}}, 3 = \text{OUT } 1, 4 = \text{OUT } 2$.
HAR[]?	Sets the harmonic multiplier H (1 - 15).
IDN?	Identification query. Returns "NEW FOCUS 3502 CHOPPER <Firmware version> <Firmware date>, SN<Serial Number>".
KEY*	Duplicates the action of pressing a front panel key: 0 = Right arrow, 1 = Down arrow, 2 = Up arrow, 3 = Left arrow, 4 = Set, 5 = Measure, 6 = Mode, 7 = Sync, 8 = Wheel.
MEM*	Accesses instrument set-up memory. 0 = Store, 1 = Recall. Use with STO and RCL commands.
MOD*?	Selects the instrument mode. 0 = H/S, 1 = +/-, 2 = NORMAL.
OSC[]?	Sets the internal synthesizer frequency to three significant digits. (4.00 Hz to 99.9 kHz in EXT+/EXT- mode; range automatically limited in INT mode).
PHS[]?	Sets the phase delay (-180.0 to +179.0).
RCL[]?	Selects instrument set-up for recall (0 - 9). 0 - factory default set-up. Use with MEM1 command.
SET*	Selects the parameter modified by the arrow keys: 0 - Synth frequency, 1 - Phase, 2 - Harmonic multiplier, 3 - Subharmonic divisor, 4 - Recall set-up, 5 - Store set-up
STO[]?	Selects instrument set-up for storage (1-9). Use with MEM command.
SUB[]?	Sets subharmonic divide ratio S (= 1 - 15).
SYN[]?	Selects the source of the sync frequency. 0 = V_{ext} , 1 = EXT+, 2 = EXT-, 3 = INT.
WHL*?	Selects the wheel. 0 = 60 slot wheel, 1 = 42/30 slot wheel, 2 = 7/5 slot wheel, 3 = 2 slot wheel, 4 = 100 slot wheel.

Table 3: Summary of computer control commands.

4.5 Command Description

FR*?

Description	Frequency query.
Syntax	FR*?
Remarks	The FR* command is used to query the following frequencies associated with the Measure key on the Chopper front panel: F_{sync} , F_{outer} , OUT 1, and OUT 2. Data is returned in Hz.
	FR1? Query F_{sync}
	FR2? Query F_{outer}
	FR3? Query frequency of OUT 1
	FR4? Query frequency of OUT 2
Example	The chopping frequency is 1.23 kHz, and the Chopper is in NORMAL mode.
	FR3? Query.
	FR36150.0 Response. The frequency at OUT 1 is 6.15 kHz.

HAR[]?

Description	Set and query H.
Syntax	HAR[]?
Remarks	The HAR command sets and queries the harmonic multiplier H, which is used in H/S mode. The data may range from 1 to 15.
Example	
	HAR2 Command. Sets H to 2.
	HAR? Query.
	HAR2 Response. H is currently set to 2.

IDN?

Description Identification query.

Syntax IDN?

Remarks Returns the following string identifying the Chopper: "NEW FOCUS 3502 CHOPPER <Firmware version> <Firmware date>, SN<Serial Number>".

Example

IDN?	Query.
NEW FOCUS	Response. The firmware version is 1.16,
3502	the firmware date is 5/05/14, and the
CHOPPER	serial number of the unit is P0004.
1.16	
5/05/14,	
SNP0004	

KEY?

Description Duplicates the action of pushing a front panel button.

Syntax KEY?

Remarks The KEY command duplicates the action of pushing one of the 9 black front panel buttons. The nine options are as follows:

KEY0	Right arrow
KEY1	Down arrow
KEY2	Up arrow
KEY3	Left arrow
KEY4	Set
KEY5	Measure
KEY6	Mode
KEY7	Sync
KEY8	Wheel

MEM?

Description Store and recall instrumental set-ups.

Syntax MEM?

Remarks The MEM command, along with the STO and RCL commands, is used to store and recall one of the 9 instrumental set-ups. After selecting which instrument set-up number to use (1 through 9) using the STO command, MEM0 will store the current instrument set-up. After selecting which instrument set-up to recall using the RCL command, MEM1 recalls the selected set-up.

Example

STO5	Selects location #5 for setup storage
MEM0	Saves setup in location #5
RCL1	Selects location #1 setup recall
MEM1	Recalls setup in location #1

MOD*?

Description Select and query the mode of operation.

Syntax MOD*?

Remarks The MOD command allows the user to query the Chopper's operating mode and to set the Chopper operating mode as follows:

MOD0	H/S
MOD1	+/-
MOD2	NORMAL

Example

MOD2	Command. Operating mode set to NORMAL.
MOD?	Query.
MOD2	Response. Operating mode is NORMAL.

OSC []?

Description Set and query the synthesizer frequency.

Syntax OSC []?

Remarks The OSC command sets and queries the internal synthesizer. In INT Sync mode setting the synthesizer frequency will set the chopping frequency. In INT Sync mode the data supplied by the OSC command is limited by the Chopper wheel minimum and maximum chopping frequencies. In the other modes of operation, the data may range from 4.00 to 99.9 kHz. Only three digits of resolution are available. The data is entered in Hz, and no decimal point should be included.

Example

OSC54300	Command. Sets the internal synthesizer to 543 Hz.
OSC?	Query.
OSC543.00	Response. The internal synthesizer's frequency is set to 543 Hz.

PHS []?

Description Set and query the phase delay.

Syntax PHS []?

Remarks The PHS command sets and queries the phase shifter. The data may range from -180.0 to +179.0 degrees. Do not use a decimal point in the data.

Example

PHS-1234	Command. Set the phase shift to -123.4 degrees.
PHS?	Query.
PHS-123.4	Response. The phase shift is set to -123.4 degrees.
PHS222	Command. Set the phase shift to 22.2 degrees.

RCL[]?

Description Selects instrument set-up for recall.

Syntax RCL[]?

Remarks The RCL command will select a formerly stored instrument set-up. The RCL? query will return the recall set-up number. The data may range between 0 and 9. Recall of set-up “0” will restore the Model 3502 Optical Chopper to factory default settings. RCL is used with MEM1 to recall the instrument set-up.

Example

RCL0	Command. Select factory default setup for recall.
MEM1	Command. Recalls factory default setup.
RCL4	Command. Select location #4 for setup recall.
RCL?	Query.
RCL4	Response. The active location for recall is location #4.
MEM1	Command. Recalls setup in location #4.

SET*

Description Selects the parameters to be modified by the arrow keys.

Syntax SET*

Remarks The SET command selects which parameter is activated so that it can be changed by the arrow keys.

SET0	Synthesizer frequency
SET1	Phase
SET2	H
SET3	S
SET4	Recall
SET5	Store

STO[]?

Description Selects instrument set-up for storage.

Syntax STO[]?

Remarks The STO command selects the instrument set-up number in which to store the current Chopper set-up. The STO? query will return the selected instrument set up number. The data may range from 1 to 9. STO is used with MEMO to store the instrument set-up.

Example

STO9	Command. Select location #9 for setup storage.
STO?	Query.
STO9	Response. Location #9 is selected for setup recall.
MEMO	Command. Recalls setup #9.

SUB[]?

Description Set and query S.

Syntax SUB[]?

Remarks The SUB command sets and queries S, the subharmonic divide ratio which is used in H/S mode. The data may range from 1 to 15.

Example

SUB7	Command. Set subharmonic divide ratio to 7.
SUB?	Query.
SUB7	Response. Subharmonic divide ratio is 7.

SYN[]?

Description Set and query the source used for synchronization.

Syntax SYN[]?

Remarks The SYN command sets and queries the frequency source used for synchronization.

SYN0	V _{ext}
SYN1	Ext+
SYN2	Ext-
SYN3	INT
SYN?	Query

Example

SYN3	Command. Set sync source to INT.
SYN?	Query.
SYN3	Response. Sync source is set to INT.

WHL[]?

Description Set and query the type of chopping wheel being used.

Syntax WHL[]?

Remarks The WHL command sets and queries the type of chopping wheel that is being used:

WHL0	60-slot wheel
WHL1	42/30-slot wheel
WHL2	7/5-slot wheel
WHL3	2-slot wheel
WHL4	100-slot wheel
WHL?	Query wheel type

Example

WHL1	Command. Select the 42/30-slot wheel.
WHL?	Query.
WHL1	Response. Selected wheel is the 42/30-slot wheel.

5 Troubleshooting



CAUTION

There are no user serviceable parts inside the Model 3502 Optical Chopper Controller or Motor Head. Work performed by persons not authorized by New Focus will void the warranty.

5.1 Normal Startup Operation

When the Chopper Controller is properly connected to the power mains and a Chopper Head, and is turned on, the front panel LEDs will blink and the display will show PASS before recalling the last Chopper Controller set up. The motor should begin turning and come to speed within about one minute.

5.2 Symptoms and Steps to Follow

If nothing happens:

Check that the power cord is connected to the Chopper Controller.

Check that the Chopper Head is connected to the Chopper Controller. Do not connect the Chopper Head when the Chopper Control unit is powered on.

Fails test at start up:

Please contact New Focus for service.

Motor fails to turn:

With power removed from the control unit, check that the wheel is free to turn without obstructions. Also, this condition may be caused by a broken shielded Ethernet cable between the Chopper Controller and the Chopper Head. Substitution of a known functional shielded Ethernet cable is the best solution.

Motor spins down and stops when sync frequency is changed:

The Chopper Controller will stop driving the motor in the Chopper Head if an externally-supplied sync frequency is outside the range of the chopping frequencies allowed for a given wheel setting. Verify that this external signal is of the correct frequency.

Synchronization to an external signal is unreliable:

Verify that the pulse width of the external trigger pulse is at least 1 μs long. Use an oscilloscope with a high impedance input to monitor the external signal while it is connected to the Chopper Controller. The input signal should have valid TTL voltage levels.

Motor oscillates wildly:

Recall the factory default settings. This will place the instrument into known conditions. If the oscillation stops, then the signal supplied via Sync In may have been unstable. Verify the stability of the input signal with an oscilloscope or frequency counter. The frequency of the signal on Sync In may have been outside of operating limits which are determined by the operating Mode, H, S, and the Wheel setting. Refer to the entry on the **FREQ** setting in Section 3.5.1 on page 24 for more details.

Observe the signal at F_{outer} on an oscilloscope. If the cable or optical sensor is damaged, the signal will remain high or low. If this is the case, replace the cable between the Chopper Controller and the Chopper Head.

Check for the correct wheel setting on the front panel.

6 Specifications

6.1 Chopping Frequency

Please note that specifications are subject to change without notice.

Wheel	Min. Freq. (F_{outer})	Max. Freq. (F_{outer})	Jitter ($\mu\text{s p-p}$, typical)	
			@ Min. Freq.	@ Max. Freq.
100	200 Hz	10.65 KHz	200	5
60	120 Hz	6.40 KHz	150	3
42/30	84 Hz	4.48 KHz	150	5
7/5	14 Hz	746 Hz	1000	15
2	4 Hz	213 Hz	2000	50

6.2 Internal Synthesizer

Stability	100 ppm after one hour warm-up.
Drift	Less than 10 ppm/ $^{\circ}\text{C}$.
Accuracy	< 1/5 of least significant digit.
Resolution	4.00 Hz - 99.9 kHz, 3 significant digits.
Range limits (INT)	Upper: [Highest wheel frequency]·S/H. Lower: [Lowest wheel frequency]·S/H.
Range limits (EXT)	4.00 Hz – 99.9 kHz

6.3 Reference Input

Sync In	TTL-level pulse, with same frequency limits as internal oscillator. Pulse width $\geq 1 \mu\text{s}$.
---------	---

6.4 Reference Output

Sync Out	TTL level square wave, may be used as free-running oscillator when using EXT+, EXT- or V_{ext} Sync setting.
F_{outer}	TTL-level square wave at the chopping frequency.
OUT 1	TTL level pulse: $5 \cdot F_{outer}$ in NORMAL mode $F_{outer} - F_{inner}$ in +/- mode $(H/S) \cdot F_{outer}$ in H/S mode.
OUT 2	TTL level pulse: F_{inner} in NORMAL mode $F_{outer} + F_{inner}$ in +/- mode $[H/(7 \cdot S)] \cdot F_{sync}$ in H/S mode.

6.5 Phase Shifter

Range:	-180.0° to +179.0°
Resolution:	0.1°, increasing to 0.25° at 6.4 kHz.

6.6 Harmonic Locking

Subharmonic (S):	1 – 15
Harmonic (H):	1 – 15
Note: S and H may be set in any combination.	

6.7 External Voltage Control

0 to -10.0 V DC for 0 to 100% of maximum chopping frequency.

6.8 General

Net Weight:	5.7 pounds (Chopper Head assembly included)
Power Input:	100-240 VAC, 50-60 Hz.

7 Maintenance and Service

7.1 Enclosure Cleaning

Before cleaning the enclosure of the Model 3502 Optical Chopper Controller, the power cord must be disconnected from the wall socket and from the unit.

The source enclosure should only be cleaned with a mild soapy water solution applied to a damp lint-free cloth. Do not use an acetone or alcohol solution; this will damage the finish of the enclosure.

7.2 Technical Support

Information and advice about the operation of any New Focus product is available from our technical support engineers.

Hours: 8:00–5:00 PST, M-F (excluding holidays)

Toll Free: 1-866-NUFOCUS (1-866-683-6287)
(from the USA & Canada only)

Phone: (408) 284-6808

Support is also available via email:

Email: techsupport@newfocus.com

We typically respond within one business day.

7.3 Technical Support Contacts

North America

New Focus

3635 Peterson Way

Santa Clara, CA 95054

Telephone: (866) 683-6287

Telephone: (408) 919-1500

Europe

Newport/MICRO-CONTROLE S.A.

Zone Industrielle

45340 Beaune la Rolande, FRANCE

Telephone: (33) 02 38 40 51 56

Asia

Newport Opto-Electronics Technologies

中国 上海市 爱都路 253号 第3号楼 3层 C部位, 邮编 200131

253 Aidu Road, Bld #3, Flr 3, Sec C, Shanghai 200131, China

Telephone: +86-21-5046 2300

Fax: +86-21-5046 2323

7.4 Service

Your Model 3502 Optical Chopper Controller and Chopper Head have been designed to provide years of trouble-free operation. Virtually no maintenance is required except for ensuring that the unit is not damaged, contaminated, or used in an unsafe manner.

Obtaining Service

The Model 3502 Optical Chopper Controller and Chopper Head contain no user serviceable parts. To obtain information regarding factory service, contact New Focus. Please have the following information available:

- Instrument model number (on the rear panel).
- Instrument serial number (on the rear panel).
- Description of the problem.

If the instrument is to be returned to New Focus, you will be given a Return Material Authorization (RMA) number, which you should reference in your shipping documents.

7.5 Warranty

New Focus, a Newport Corporation company, guarantees its products to be free of defects for one year from the date of shipment. This is in lieu of all other guarantees, expressed or implied, and does not cover incidental or consequential loss.

Note that the life of the motor is limited. Long-term high-speed use of the motor will result in faster wear and a shorter lifetime. Because of this limited lifetime, the Chopper Head has a 90 day warranty, while all other parts have a one year warranty.