

Installation and Setup Manual

020-101412-02

Christie Velvet LED Display System



NOTICES

COPYRIGHT AND TRADEMARKS

Copyright ©2015 Christie Digital Systems USA Inc. All rights reserved.

All brand names and product names are trademarks, registered trademarks or trade names of their respective holders.

GENERAL

Every effort has been made to ensure accuracy, however in some cases changes in the products or availability could occur which may not be reflected in this document. Christie reserves the right to make changes to specifications at any time without notice. Performance specifications are typical, but may vary depending on conditions beyond Christie's control such as maintenance of the product in proper working conditions. Performance specifications are based on information available at the time of printing. Christie makes no warranty of any kind with regard to this material, including, but not limited to, implied warranties of fitness for a particular purpose. Christie will not be liable for errors contained herein or for incidental or consequential damages in connection with the performance or use of this material. Canadian manufacturing facility is ISO 9001 and 14001 certified.

WARRANTY

Products are warranted under Christie's standard limited warranty, the complete details of which are available by contacting your Christie dealer or Christie. In addition to the other limitations that may be specified in Christie's standard limited warranty and, to the extent relevant or applicable to your product, the warranty does not cover:

- a. Problems or damage occurring during shipment, in either direction.
- b. Projector lamps (See Christie's separate lamp program policy).
- c. Problems or damage caused by use of a projector lamp beyond the recommended lamp life, or use of a lamp other than a Christie lamp supplied by Christie or an authorized distributor of Christie lamps.
- d. Problems or damage caused by combination of a product with non-Christie equipment, such as distribution systems, cameras, DVD players, etc., or use of a product with any non-Christie interface device.
- e. Problems or damage caused by the use of any lamp, replacement part or component purchased or obtained from an unauthorized distributor of Christie lamps, replacement parts or components including, without limitation, any distributor offering Christie lamps, replacement parts or components through the internet (confirmation of authorized distributors may be obtained from Christie).
- f. Problems or damage caused by misuse, improper power source, accident, fire, flood, lightening, earthquake or other natural disaster.
- g. Problems or damage caused by improper installation/alignment, or by equipment modification, if by other than Christie service personnel or a Christie authorized repair service provider.
- h. Problems or damage caused by use of a product on a motion platform or other movable device where such product has not been designed, modified or approved by Christie for such use.
- i. Problems or damage caused by use of a projector in the presence of an oil-based fog machine or laser-based lighting that is unrelated to the projector.
- j. For LCD projectors, the warranty period specified in the warranty applies only where the LCD projector is in "normal use" which means the LCD projector is not used more than 8 hours a day, 5 days a week.
- k. Except where the product is designed for outdoor use, problems or damage caused by use of the product outdoors unless such product is protected from precipitation or other adverse weather or environmental conditions and the ambient temperature is within the recommended ambient temperature set forth in the specifications for such product.
- l. Image retention on LCD flat panels.
- m. Defects caused by normal wear and tear or otherwise due to normal aging of a product.

The warranty does not apply to any product where the serial number has been removed or obliterated. The warranty also does not apply to any product sold by a reseller to an end user outside of the country where the reseller is located unless (i) Christie has an office in the country where the end user is located or (ii) the required international warranty fee has been paid.

The warranty does not obligate Christie to provide any on site warranty service at the product site location.

PREVENTATIVE MAINTENANCE

Preventative maintenance is an important part of the continued and proper operation of your product. Please see the Maintenance section for specific maintenance items as they relate to your product. Failure to perform maintenance as required, and in accordance with the maintenance schedule specified by Christie, will void the warranty.

REGULATORY

The product has been tested and found to comply with the limits for a Class A digital device, pursuant to Part 15 of the FCC Rules. These limits are designed to provide reasonable protection against harmful interference when the product is operated in a commercial environment. The product generates, uses, and can radiate radio frequency energy and, if not installed and used in accordance with the instruction manual, may cause harmful interference to radio communications. Operation of the product in a residential area is likely to cause harmful interference in which case the user will be required to correct the interference at the user's own expense.

CAN ICES-3 (A) / NMB-3 (A)

이 기기는 업무용(A급)으로 전자파적합등록을 한 기기이오니 판매자 또는 사용자는 이점을 주의하시기 바라며, 가정 외의 지역에서 사용하는 것을 목적으로 합니다.

Environmental

The product is designed and manufactured with high-quality materials and components that can be recycled and reused. This symbol  means that electrical and electronic equipment, at their end-of-life, should be disposed of separately from regular waste. Please dispose of the product appropriately and according to local regulations. In the European Union, there are separate collection systems for used electrical and electronic products. Please help us to conserve the environment we live in!

Content

Product overview.	4
Terminology.	4
Related documentation.	4
Typical LED solution.	5
Installation and setup.	6
Safety guidelines.	6
AC/power precautions.	7
Cable and control unit layout and design.	7
Christie E400 LED Display Controller interface and ports.	8
Installing the tiles.	9
(Optional) Installing the EOC410 and EOC420 fiber extenders.	12
Routing the cable.	13
Installing the Christie E400 LED Display Controller software.	13
Connecting to video sources.	14
Powering on the Velvet LED Display System array.	14
Powering off the LED display system array.	14
Testing the communication between the control unit and tiles.	14
Reviewing and modifying the tile configuration.	15
Specifications.	16
Physical specifications.	16
Display.	16
Power requirements - Input rating.	17
Environment.	17
Resolution requirements.	18
Regulatory.	18
Safety.	18
Approvals.	18
Electro-magnetic compatibility.	19

Product overview

Christie Velvet LED Display System (LED015-M, LED019-M, LED025-M, LED030-M, and LED040-M) are modular, high-quality image display units that can be configured into any size or shape.

The low energy consumption and the long service life of LED technology create display walls that last. LED display systems can be quickly and easily deployed into small display configurations, while providing the additional features required for larger and more complex installations.

Terminology

Learn about the components of the LED display system.

Term	Definition
Tile	A cabinet containing several LED modules.
Array	A group of connected tiles forming a larger display.
Control unit	Controls the LED display system array and video input source.
Pixel	A group of one red, one green, and one blue dot.
Subpixel	A pixel is comprised of three subpixels, one for each color: red, green, and blue. Each subpixel in LED display technology is an LED chip.
Pixel pitch	Specifies the shortest distance from the center of one pixel to the center of the next pixel.
SMD package size	A technical supplier specification related to the pixel size, and denotes the size of the surface-mounted diode (SMD) itself, for example, the 2.5 mm LED tile has a 2121 SMD package size (2121 = 2.1 mm by 2.1 mm).
Fill factor	Indicates the ratio between the area covered by pixels and the area not covered by pixels.

Related documentation

Additional information on the Velvet LED Display System is available in the following documents.

Christie E400 LED Display Control System Software User Manual (P/N: 020-101756-xx)

Typical LED solution

A typical LED display system installation contains a variety of components.

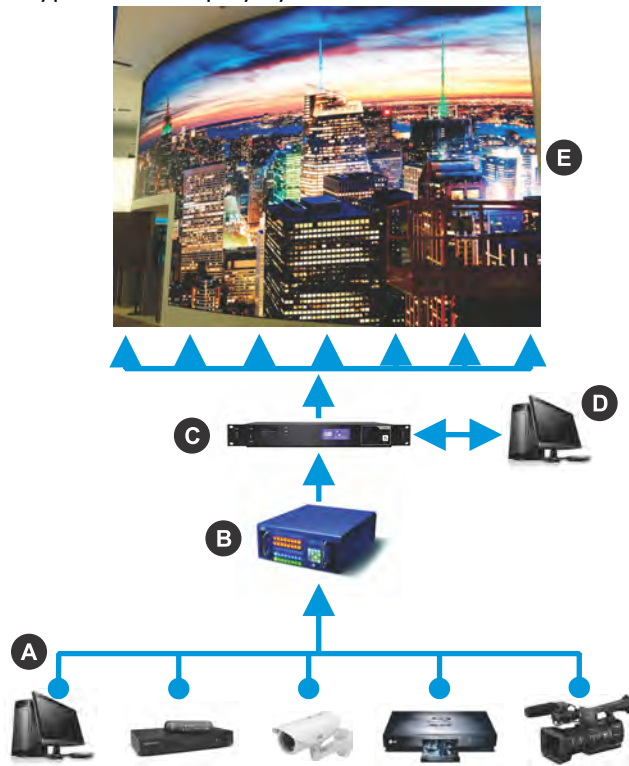

A	Media sources
B	Video matrix switch and splicing video processor (Vista X20)
C	Christie E400 LED Display Controller
D	Control computer
E	LED display

Installation and setup

The configuration of an array depends on the installation. Use the following instructions as a guideline only. Before installing, you must fully understand all site requirements and characteristics.

Safety guidelines

To avoid personal injury or damage to the display system, read this information thoroughly before installing the Velvet LED Display System tiles.



Warning! Failure to comply with the following could result in death or serious injury.

- SHOCK HAZARD! Disconnect the product from AC before servicing, cleaning, removing components, or opening any enclosure.
- SHOCK HAZARD! Do not touch the power supply when the power is on.
- SHOCK HAZARD! Observe all electrostatic precautions. Use a grounded wrist strap and insulated tools when handling, servicing, or cleaning electronic assemblies.



Notice. Failure to comply with the following may result in property damage.

- Always wear clean, lint-free gloves when handling the product.

AC/power precautions

Ensure all power precautions are understood before installing the product.



Warning! Failure to comply with the following could result in death or serious injury.

- A certified electrician must be present during installation.
- Always connect the ground first to reduce shock hazard.
- Do not return the current through the ground.
- SHOCK HAZARD! The line cord has a maximum power carrying capability. For the maximum number of tiles that may be connected per daisy chain when connecting to the power supply, refer to the product specifications.
- SHOCK HAZARD! A permanent single-phase connection must be installed between the LED tile system and the AC power supply.
- FIRE AND SHOCK HAZARD! Do not operate the system unless certified power connections, providing the recommended voltage, are used.
- HIGH TOUCH CURRENT HAZARD! To ensure reliable grounding, the power connection must be made by using an industrial plug (pluggable type B), or be provided by a permanent connection.
- A 13-20 A double pole mains circuit breaker, certified for the applicable local regulations, is required. It must be part of the building installation and easily accessible.
- Do not use a wall breaker greater than 20 A. This could result in severe damage to the tile system in the event of a failure.



Caution! Failure to comply with the following could result in minor or moderate injury.

- SHOCK HAZARD! Only use the AC power cord provided with the product or recommended by Christie.
- TRIP OR FIRE HAZARD! Position all cables where they cannot contact hot surfaces, be pulled, be tripped over, or damaged by persons walking on or objects rolling over the cables.
- FIRE HAZARD! Do not use a power cord that appears damaged.
- FIRE OR SHOCK HAZARD! Do not overload power outlets and extension cords.
- Only Christie qualified technicians are permitted to open product enclosures.

Cable and control unit layout and design

Before an array is constructed, you must plan the design layout of the tiles to make sure that control unit placement and the cabling layout support the overall tile design objectives.

The LED display system offers considerable flexibility in terms of the number of media sources that can be displayed and the overall resolution. Color and brightness matching, as well as other functions, may be performed across an entire array.

The video source connections between the cabinets is represented by the blue line. The power connections between the cabinets is represented by the red line.

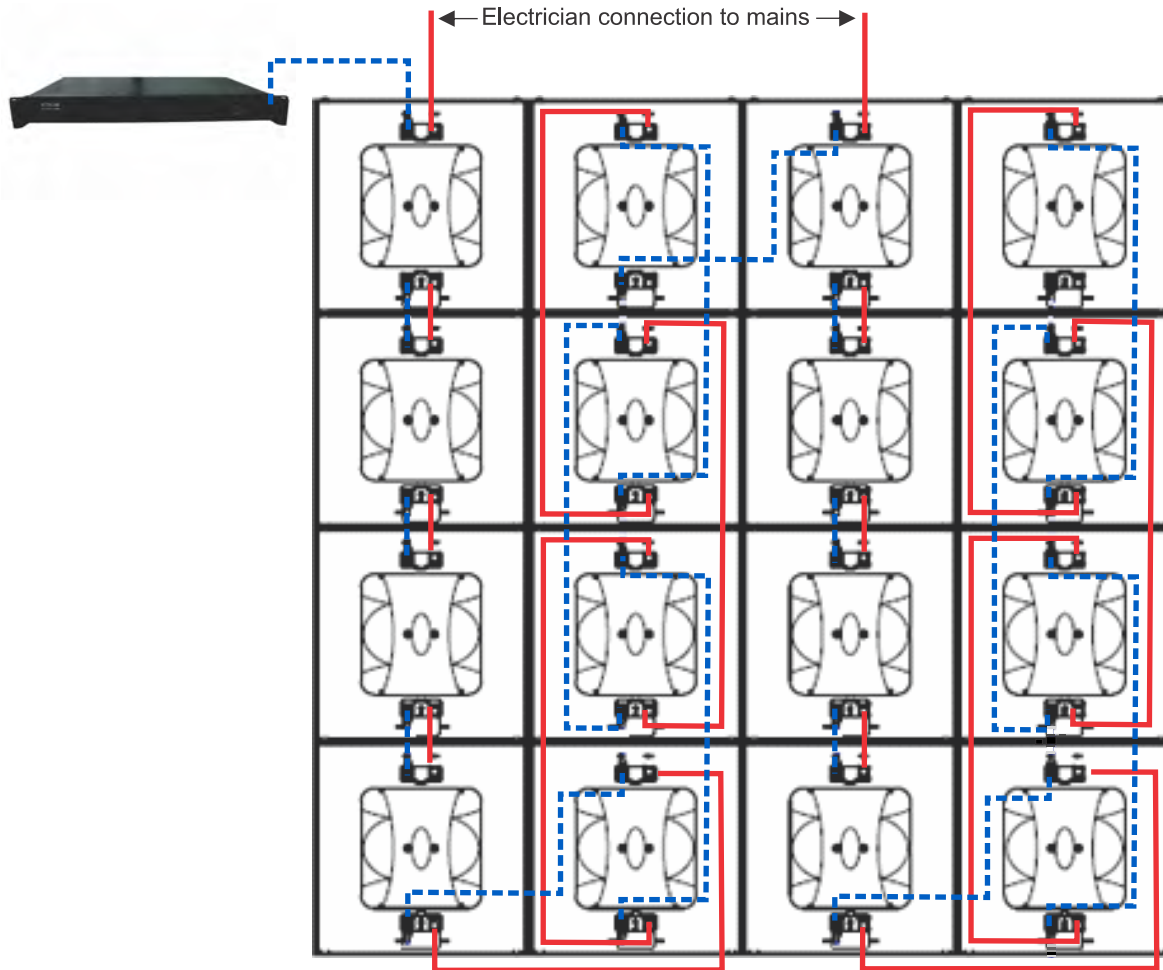

When installing the cables from tile to tile, consistently use either the top or bottom ports for all input connections, and the other set of ports for the output connections.

Christie E400 LED Display Controller interface and ports

Learn about the physical ports on the Christie E400 LED Display Controller.

Front



Inputs/Outputs	Description
RUN	<ul style="list-style-type: none"> When no video source is available, the green light blinks quickly. When a video source is available, the green light blinks normally. When the redundancy works, the indicator green light fades gradually.
STA (Status)	<ul style="list-style-type: none"> When the equipment is running, the red light is on. When authorization is occurring, the red light blinks.
PWR (Power)	<ul style="list-style-type: none"> When the PWR button is lit, the Christie Christie E400 LED Display Controller is on.

Rear

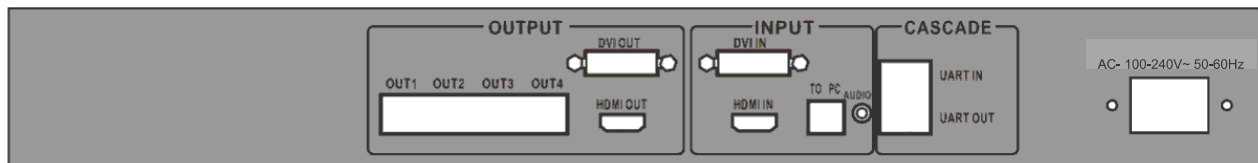

Inputs/Outputs	Description
DVI IN	DVI input
DVI OUT	DVI output
OUT1-OUT4	Output for four network interfaces
HDMI IN	HDMI input
HDMI OUT	HDMI output
To PC	Computer USB connection
AUDIO	Audio input
UART IN	The cascading input interface of the serial ports
UART OUT	The cascading output interface of serial ports
AC 100-240V~ 50/60HZ	AC power interface

Installing the tiles

Install the tiles in the array row by row. Do not attempt to construct the array column by column. Power on each tile to ensure it is functioning before installing it.



Warning! Failure to comply with the following could result in death or serious injury.

- External support for a display wall must be designed and implemented by a Christie qualified installer and must comply with local area regulations and safety standards.
- All display walls must have permanent external supports. The amount of external support required depends on the size of the display wall.
- A minimum of two people or lift equipment is required to safely lift, install, or move the product.

1. Ensure the external support structure is anchored to the wall and/or floor.
The design and anchoring of the LED display structure is not the responsibility of Christie Digital Systems. Contact a Christie representative for structure design options.
2. Mount the tiles to the support structure using one of the following methods:
 - a) To provide lateral stability, attach the panel to an external support by the slotted locking pins located on the rear cover of the tile.

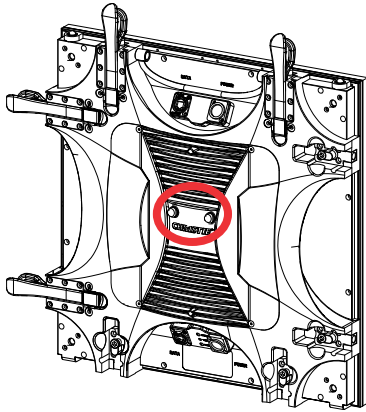

- b) Attach the tiles to the support structure using M10 bolts in the four mounting points. Ensure the M10 bolts have at least 4 mm, or three full revolutions, of thread engagement into the tile.

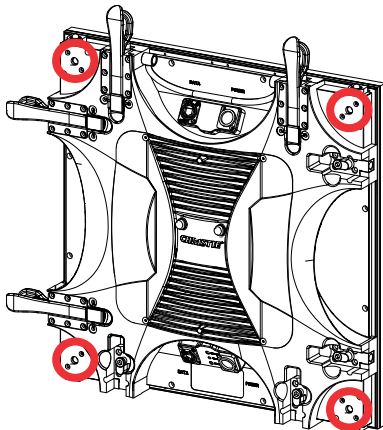

3. Install the first tile in the center of the bottom row, ensuring it is level.
4. Install the next tile in the row beside the center tile.
To help with aligning the tiles in the row, each side of the tile has locating pins and holes.



5. Adjust the tiles until they are level and no gaps exist between the displays in the array.

6. Using the locking mechanism, pull the second tile tight against the center cube.
 - a) Press and hold the locking button below the spanner.



- b) Pull down the spanner.
 - c) Lift the metal loop and place it around the locking mechanism screw on the second tile.



Make the same adjustments to the locking mechanism screw across all panels. If the screw is not the same depth on all panels, the panels may be misaligned and the uneven tension between the panels may affect the image quality.

- d) Push the spanner in until it is flat against the tile.
 - e) Repeat steps 6a to 6d for each locking mechanism on the panel.
7. Repeat steps 3 to 6 for all remaining tiles to be used in the first row.
Complete installing all tiles in the first row before installing the second row.
8. Repeat steps 2 to 8 for all rows in the array.

(Optional) Installing the EOC410 and EOC420 fiber extenders

A fiber optic extender increases the available distance between the LED display and the controller. The extenders are optional to the configuration of the array, and may be necessary based on the signal strength from the control unit.

Each model of fiber extender can relay content over a specified distance; the EOC410 Single-mode (SM) fiber extender increases the transmission distance by 15 KM, and the EOC420 Multi-mode (MM) fiber extender increases the transmission distance by 300 meters. Multiple extenders can be chained together between the control unit and the array to extend the distance even further.

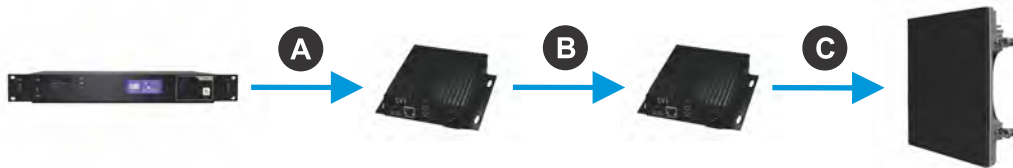

Notice. Failure to comply with the following may result in property damage.

- Do not bend the fiber optic cables beyond their minimum bend radius. Sharp bends can damage the cables and cause transmission problems.
- Always keep a protective cap on disconnected fiber optic cables.

1. Connect the power cord to the fiber extender.
2. Plug the Ethernet cable from the control unit into the fiber extender (A).
3. Connect the fiber optic cables between the two fiber optic extenders (B).
 - a) Remove the covers from the fiber optic cable ends.
 - b) Remove the protective plug from the fiber optic ports on the extender.



- c) Connect one fiber optic cable into the TX port on each extender.
 - d) Connect the other fiber optic cable into the RX port on each extender.

If the fiber optic cables are not plugged into the same port on each extender, the LED panels do not display any content.
4. Plug an Ethernet cable into the last extender in the chain and connect it to the first panel in the array (C).
 5. Plug the fiber extender power cables into a wall socket.
 6. Power on all the components in the tile configuration.

Routing the cable

When installing the cables from tile to tile, consistently use either the top or bottom ports for all input connections, and the other set of ports for the output connections.

The line cord has a maximum power carrying capability. For the maximum number of tiles that may be connected per daisy chain when connecting to the power supply, refer to the specifications in this manual. One inlet signal cable can connect to no more than 16 screen cases.

Top connections

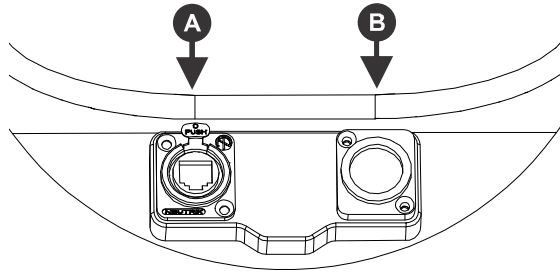

Bottom connections

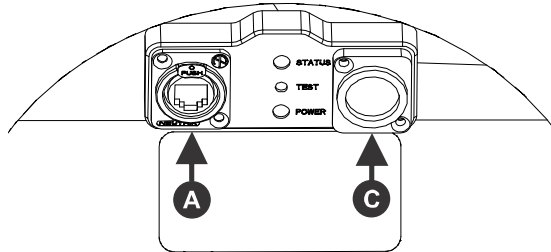

A	Data connections
B	Input power connections
C	Output power connections

1. Connect the network cable between the Christie E400 LED Display Controller and the first tile in the array.
2. Daisy chain the display port cables from one tile to the next. You do not need to make a complete loop between the Christie E400 LED Display Controller and the tiles; however, with a complete loop, communication to the entire array is not lost if one tile fails.
3. Daisy chain the power cables from one tile to the next, to a maximum of nine tiles.
4. Plug the USB cable from the controller to the computer that will be directly connected to the Christie E400 LED Display Controller.

Related information

Cable and control unit layout and design (on page 7)

Installing the Christie E400 LED Display Controller software

The Christie E400 LED Display Controller software controls the configuration of the array.

1. Insert the Christie E400 LED Display Controller software CD in the computer.
2. Follow the on screen instructions and install the Christie E400 LED Display Controller software.

Connecting to video sources

A Velvet LED Display System array requires a Christie E400 LED Display Controller to display an image using a source, connected with an HDMI or DVI cable, ensuring the supplied video signal is properly displayed across the entire array.

After the Christie E400 LED Display Controller is connected and powered up, the video content is available as long as the video source is connected.

Connect the HDMI or DVI output from the video source (computer or media player) to the appropriate input port on the Christie E400 LED Display Controller.

Powering on the Velvet LED Display System array

If the screen is not in use for more than three days, light the screen with 30% of maximum brightness for more than three hours and then with 80% to 100% of maximum brightness to get rid of moisture.

When the environment temperature is between -10 to 0 degrees Celsius, keep the screen blank more than 180 seconds after it starts.

1. Start the computer that is the video source.
2. Turn on the breaker for the array.
3. Turn on the Christie E400 LED Display Controller.

Powering off the LED display system array

When powering off in preparation for inspection or maintenance, always disconnect from AC.

Avoid switching the panel on and off while it is under full luminance (when the background of the computer monitor is white) as the surge current of power supply system is at the maximum value. There must be at least five minutes between turning the off the array and restarting it.

1. Turn off the Christie E400 LED Display Controller.
2. Turn off the computer.
3. Turn off the breaker for the LED array.

Testing the communication between the control unit and tiles

Verify that the array is connected and recognized by the Christie E400 LED Display Controller.

1. Launch the Christie E400 LED Display Controller software and login as the administrator.
 - a) Click **User > Advanced Login**.
 - b) Login with the password **admin**.
2. To confirm the display is connected and recognized by the control unit, in the Local System Info area ensure **Control System** has a value of **1**.

3. Switch to the **Display Control** tab.
4. To confirm the control unit is communicating with all tiles, select a color from the **Self Test** list and click **Send**.
If the control unit is communicating with all the tiles, each display changes to the selected color.
5. Reset the Self Test to **Normal** and click **Send**.
6. Close the Screen Control dialog.

Reviewing and modifying the tile configuration

Review the tile configuration reported in the Christie E400 LED Display Controller software.

1. Click **Screen Config**.
2. Select **Config Screen** and click **Next**.
3. On the Sending Board tab of the Screen Config dialog, select the resolution of the video source and click **Set**.
 - The native display resolution is 320 px by 240 px.
 - Change the X and Y coordinates to move the 320 x 240 window, as long as the source size is not exceeded.
4. Click **Save**.
5. Switch to the **Screen Connection** tab.
6. Click **Read from HW**.
7. Review the configuration of the tiles in the array, and modify as needed.
The cable layout for the tiles in the array is identified with an S where the first CAT-5 cable starts, and the green line shows the path of the daisy chain of cables. E identifies the end of the daisy chain.

Specifications

Learn about the product specifications. Due to continuing research, specifications are subject to change without notice.

Physical specifications

Learn the dimensions and weight of the tiles.

	LED015-M	LED019-M	LED025-M	LED030-M	LED040-M
Tile dimensions (W x H x D)	480.0 mm x 480.0 mm x 160.1 mm (16.54 in x 16.54 in x 6.30 in)				
Tile resolution	312 px x 312 px	252 px x 252 px	192 px x 192 px	160 px x 160 px	120 px x 120 px
Tile weight	11.5 kg (25.38 lb)				
Tile design	Die-cast aluminum				
Service access	Requires both front and rear access				
Module dimensions (W x H)	240 mm x 120 mm	240 mm x 240 mm	160 mm x 160 mm	240 mm x 240 mm	240 mm x 240 mm
Module resolution	156 px x 78 px	126 px x 126 px	64 px x 64 px	80 px x 80 px	40 px x 40 px

Display

Learn about the display specifications.

	LED015-M	LED019-M	LED025-M	LED030-M	LED040-M
Pixel pitch	1.538 mm	1.9 mm	2.5 mm	3.0 mm	4.0 mm
Pixel size	1010 (1.0 mm x 1.0 mm)	1010 (1.0 mm x 1.0 mm)	2121 (2.1 mm x 2.1 mm)	2121 (2.1 mm x 2.1 mm)	2121 (2.1 mm x 2.1 mm)
Pixel configuration	3 in 1 (1R1G1B)				

Power requirements - Input rating

Learn the power requirements for the projector.

		Input rating
LED Tile	LED015-M	100-240 V~, 50/60Hz, 2.4A, 240 watts (max. 12A, max. 5 tiles)
	LED019-M	100-240 V~, 50/60Hz, 2.4A, 240 watts (max. 12A, max. 5 tiles)
	LED025-M	100-240 V~, 50/60Hz, 1.5A, 150 watts (max. 12A, max. 9 tiles)
	LED030-M	100-240 V~, 50/60Hz, 1.5A, 150 watts (max. 12A, max. 9 tiles)
	LED040-M	100-240 V~, 50/60Hz, 1.5A, 150 watts (max. 12A, max. 9 tiles)
Christie E400 LED Display Controller		100-240 V~, 50-60 Hz, 0.7A, 70 watts
LED SM Fiber Extender (EOC410)		100-240 V~, 50-60 Hz, 0.7A, 70 watts
LED MM Fiber Extender (EOC420)		100-240 V~, 50-60 Hz, 0.7A, 70 watts

Environment

Learn about the environment requirements for the product while operating and not operating.

Non-operating environment

Item	Description
Tile temperature	-10°C to 55°C (-14°F to 131°F)
Tile humidity (non-condensing)	10% to 90%

Operating environment

Item	Description
Tile temperature	0°C to 40°C (32°F to 104°F)
Tile humidity (non-condensing)	10% to 90%
Altitude	0 to 3000 meters
Control unit temperature	-20°C to 60°C (-4°F to 140°F)
Control unit humidity	10% to 90%

Resolution requirements

- The maximum vertical and horizontal resolutions may vary. Contact a Christie representative for support, if required.
- 8 bit sources (30 Hz - 120 Hz)—All resolutions from 640 x 480 to 1920 x 1200 refer to standard resolutions selectable within the Christie E400 LED Display Controller software
- 8 bit sources (30 Hz - 60 Hz)—Resolutions 2048 x 1152 and 2560 x 960
- 10/12 bit sources (30 Hz - 60 Hz)—All resolutions from 640 x 480 to 1440 x 900
- Custom resolutions are accepted by following the formula below. Custom input is restricted to Single Link DVI/HDMI, using a recommended 94% of the pixels.

The maximum bandwidth of each output is 1Gbit/second, and is calculated with this formula:

Pixel Number x Frame Rate x (Red bit depth + Green bit depth + Blue bit depth)

8 bit calculation	1G = Pixel Num x Frame Rate x (8+8+8)
10 bit calculation	1G = Pixel Num x Frame Rate x (10+10+10)
12 bit calculation	1G = Pixel Num x Frame Rate x (12+12+12)

For example, the 10 bit calculation for a 60Hz DVI signal is:

- $1G = \text{Pixel Number} \times 60 \times (10+10+10)$
- Pixel Number: $555,555 \times 94\% = 522,221$ pixels
- Multiply the number of pixels by the number of ports: $522,221 \times 4 = 2,088,884$

Regulatory

This product conforms to the following regulations related to product safety, environmental requirements and electromagnetic compatibility (EMC).

Safety

- CAN/CSA C22.2 No. 60950-1
- ANSI/UL 60950-1
- IEC 60950-1
- EN 60950-1
- IEC 62471-1

Approvals

This product is designed and built to comply with all relevant directives, standards, safety, health and environmental rules and regulations required for the product to be sold in: USA/Canada, EU, Australia/New Zealand, Kuwait, China, Korea, Japan, Mexico, Ukraine, Russia, India, Argentina, Brazil, Singapore, South Africa, and Saudi Arabia.

Electro-magnetic compatibility

Emissions

FCC CFR47, Part 15, Subpart B, Class A

CAN ICES-3 (A) / NMB-3 (A)

CISPR 22/EN 55022, Class A

- IEC 61000-3-2/EN61000-3-2

Immunity

CISPR 24/EN55024

- IEC 61000-3-3/EN61000-3-3

IEC/EN61000

- IEC 61000-4-2/EN61000-4-2
- IEC 61000-4-3/EN61000-4-3
- IEC 61000-4-4/EN61000-4-4
- IEC 61000-4-5/EN61000-4-5
- IEC 61000-4-6/EN61000-4-6
- IEC 61000-4-8/EN61000-4-8
- IEC 61000-4-11/EN61000-4-11

Environmental

EU Directive (2011/65/EU) on the restriction of the uses of certain hazardous substances (RoHS) in electrical and electronic equipment and the applicable official amendment(s).

EU Regulation (EC) No. 1907/2006 on the registration, evaluation, authorization and restriction of chemicals (REACH) and the applicable official amendment(s).

EU Directive (2012/19/EU) on waste and electrical and electronic equipment (WEEE) and the applicable official amendment(s).

China Ministry of Information Industry Order No.39 (02/2006) on the control of pollution caused by electronic information products, hazardous substances concentration limits (SJ/T11363-2006), and the applicable product marking requirements (SJ/T11364-2006).



Corporate offices

USA – Cypress
ph: 714-236-8610
Canada – Kitchener
ph: 519-744-8005

Consultant offices

Italy
ph: +39 (0) 2 9902 1161

Worldwide offices

Australia
ph: +61 (0) 7 3624 4888
Brazil
ph: +55 (11) 2548 4753
China (Beijing)
ph: +86 10 6561 0240
China (Shanghai)
ph: +86 21 6278 7708

Eastern Europe and
Russian Federation
ph: +36 (0) 1 47 48 100
France
ph: +33 (0) 1 41 21 44 04
Germany
ph: +49 2161 664540

India
ph: +91 (080) 6708 9999
Japan (Tokyo)
ph: 81 3 3599 7481
Korea (Seoul)
ph: +82 2 702 1601
Republic of South Africa
ph: +27 (0)11 510 0094

Singapore
ph: +65 6877-8737
Spain
ph: +34 91 633 9990
United Arab Emirates
ph: +971 4 3206688
United Kingdom
ph: +44 (0) 118 977 8000