

# Mifare<sup>®</sup> DESFire Reader

## User's Manual



REV.A  
January 19, 2009

**Table of Contents**

Mifare® Configurable Sector Reader ..... 3

Mifare® Application Directory (MAD) Support: ..... 4

Mifare User-Data Format ..... 5

Wires Assignment ..... 6

Mifare DESFire Reader Utility ..... 7

    1. DESFire Settings: ..... 7

    2. Mifare Settings: ..... 8

    3. Reader Settings ..... 10

    4. LED / Buzzer Settings ..... 11

    5. Wiegand Setting: ..... 13

    6. ABA-TK2 Settings ..... 14

    7. RS232 Setting: ..... 15

    8. Configured Card: ..... 16

    9. Test DESFIRE Reader after configuration ..... 17

ANNEX A. Hardware Specification ..... 18

ANNEX B. Wiegand Interface ..... 19

ANNEX C. ABA TK2 Interface ..... 20

ANNEX D. RS232 Interface ..... 21

ANNEX E. External LED/Buzzer Control ..... 22

ANNEX F. Order Information ..... 23

ANNEX G. WebISP - Firmware Upgrade Utility ..... 24

ANNEX H. Configured Card ..... 26

ANNEX I. History ..... 27

## Mifare<sup>®</sup> Configurable Sector Reader

### Overview:

DESFire Reader is a user configurable mifare<sup>®</sup> sector data reader. It can be configured to read mifare<sup>®</sup> card with MAD1/MAD2/MAD3 standard in a mifare<sup>®</sup> application open system, or can be configured to read the user-defined sector data (Non-MAD) in a user defined closed system.

Output interface can be configured as an RS232 output or Wiegand output. Wiegand output is selectable up to 128 bits.

DESFire Reader can also be set with a Reader ID number for multi-unit communication.

### Features:

1. Support MAD1/MAD2/MAD3 standard, and support customer MAD-AID setting.
2. Support Non-MAD format with user-defined sector number.
3. Support used card with data offset and length.
4. Support Multi Sectors.
5. Support Mifare<sup>®</sup> Standard 4K or Mifare<sup>®</sup> Standard 1K card.
6. Each Reader with Reader ID for multi-link application.
7. Output interface: Wiegand (Default), ABA-TK2 and RS232.
8. Wiegand output selectable from 1 bits to 128 bits.
9. RS232 output packet can be set with Header, Reader ID and Trailer.

### Application:

1. Access Control.
2. Time Attendance.
3. Guest Registration System.
4. Academic Services.
5. Info Services.

**Mifare® Application Directory (MAD) Support:**

DESFIRE READER support the MAD format card, the MAD (mifare® application directory) standard proposes the introduction of common data structures for card application directory entries. DESFIRE Reader should take advantage of this feature using those sector pointers instead of physical sector number.

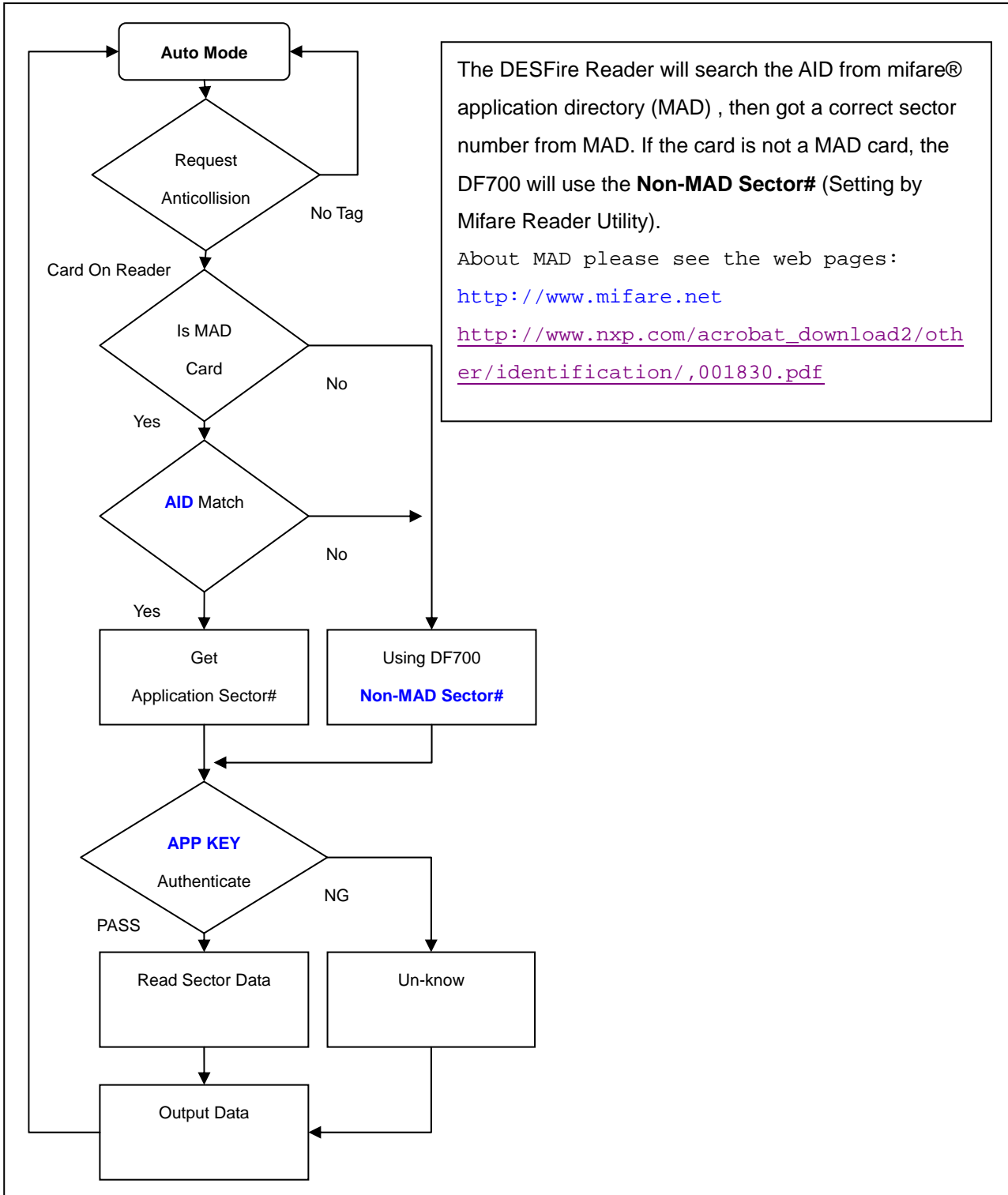

**Mifare User-Data Format**

DESFIRE READER will send out the data following the format as below, the user data length defined by the Data-Info. At wiegand output format, the data output length is fixed (defined by Number Of Bits), so the user data would be cut if longer than Number of Bits, or the user data would be appended with zero "0" if shorter than Number of Bits.

		Byte 0	Byte 15
Application Sector #	Block 0	<b>Data-Info</b>	<b>USER DATA (Max 128 Bytes)</b>
	Block 1		
	Block 2		
	Block 3		



Data-Info			
bit7	bit6	bit5	bit0
Data Type (11b)		Data Length	

Data Type is fixed with 11b which meets "any other data" type of "Card Holder information" as MAD standard.

And data length is including the data with ending zero "0", so the number of data byte sent by DESFIRE READER is equal to data length with one less for RS232 output.

Example: Data Length is 16, DESFIRE READER only send out 15 bytes for RS232 output.

## Wires Assignment

Color	Symbol	I/O	Description
Red	VCC	IN	Power Input : DC 7.5V~12V
Black	GND	IN	Power Ground
White	DATA 1	OUT	Wiegand Data 1 Signal / ABA TK2 Clock (Strobe)
Green	DATA 0	OUT	Wiegand Data 0 Signal / ABA TK2 Data
Yellow	TXD	OUT	RS232 TXD (To Host RXD)/ RS485+(for DF710)
Blue	RXD	IN	RS232 RXD (To Host TXD)/ RS485-(for DF710)
Orange	CP	OUT	ABA TK2 Card Present
Brown	LED/BUZEER	IN	External LED/BUZZER Control

To configure the DESFIRE Reader you need connect the reader to the MF700KIT first as below:

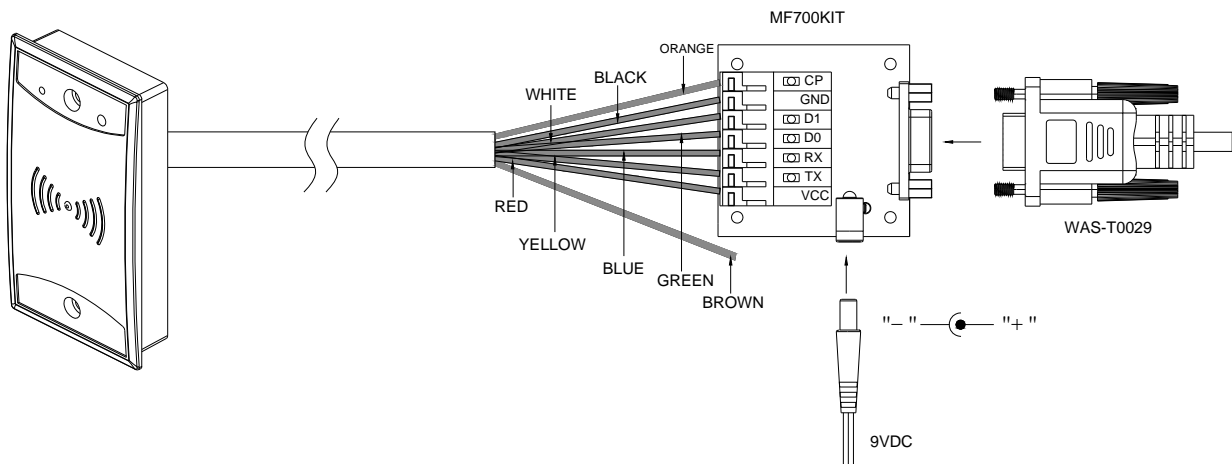

The above housing is for reference only

### Note:

MF700KIT is a test connection kit for DESFIRE READER configuration use. It is an optional item for purchasing.

## Mifare DESFire Reader Utility

### 1. DESFire Settings:

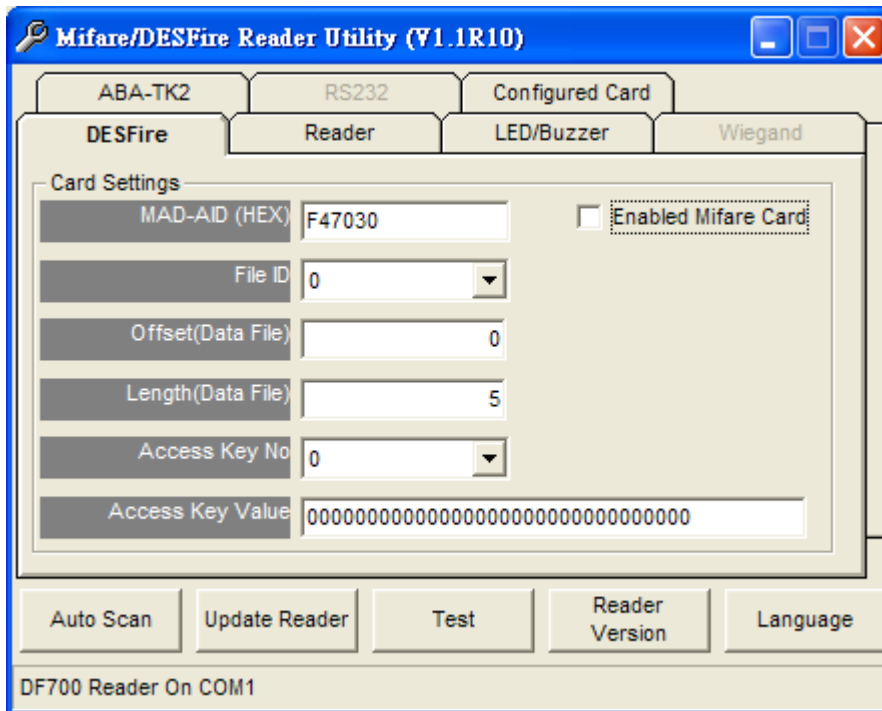

#### MAD-AID: (Default=F47030)

MAD Application Identifier number is authorized and assigned by Mifare.net upon the customer's request for registered Application Identifier in a mifare® application open system (AID: 000000h~FFFFFFh). Or it is also possible for the user to define the AID himself for the application in user defined closed system without registering into MAD group. According to the AID, DESFIRE READER can find and read the corresponding application on the card.

#### File ID: (Default=0)

File ID is 0~15. There are three file type. Data file, Value file and Record file. DESFire Reader will auto detect the type and output the data.

#### Offset/Length: (Default=0 / 5)

The Data file will depend on the value to output data. The Value file will be sent the value out. The Record file will be sent the latest record data.

#### Access Key No/Value: (Default=0 / 00000000000000000000000000000000)

Key must be the same as the Read or Read/Write KEY of the card issued. This means DESFIRE READER only can read the data on the card with the same KEY.

## 2. Mifare Settings:

Mark on "Enabled Mifare Card", and this tab will be visible.

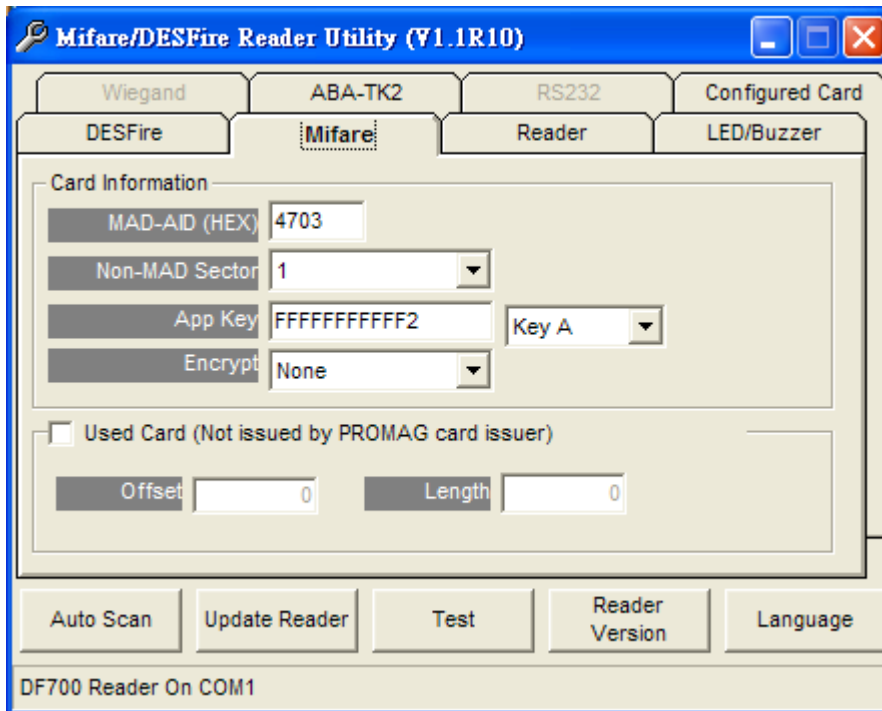

### **MAD-AID: (Default=4703)**

MAD Application Identifier number is authorized and assigned by Mifare.net upon the customer's request for registered Application Identifier in a mifare® application open system (AID: 0000h~FFFFh).

Or it is also possible for the user to define the AID himself for the application in user defined closed system without registering into MAD group. According to the AID, DESFIRE READER can find and read the corresponding sector on the MAD card.

### **Non-MAD Sector: (Default =0)**

When the card is Non-MAD format, DESFIRE READER will only read the "Non-MAD Sector".

(1K Card Sector: 0~15, 4K Card Sector:0~39). For the Non-MAD application, user can freely define the Sector.

### **App Key (KEY\_A): (Default=FFFFFFFFF2)**

App Key must be the same as the KEY\_A of the card issued. This means DESFIRE READER only can read the sector data on the card with the same KEY\_A.



**Encrypt: (Default=None)**

Fraud prevention, Select Encrypt Mode (None, Encrypt 1, Encrypt 2, Encrypt 3, Encrypt 4, Encrypt 5) to protected your card data. (Remark: Encrypt mode must to work together with the same encrypt mode of “Mifare Card Issuer” software.)

**Used Card (Not issued by “Mifare Card Issuer”)**

You have to indicate the data position in the card, when the card is not issued by “Mifare Card Issuer” software. And you must set the “Offset” (Max 255, and base from zero) form the beginning of sector and set your data “Length” (Max 128).

Example:

If your card data in the grey grid of sector, you have to set the “Offset” = 17, and set the “Length”= 20.

	AID Sector (or Non-MAD Sector)															
Block 0	0	1	2	3	4	5	6	7	8	9	10	11	12	13	14	15
Block 1	16	17	18	19	20	21	22	23	24	25	26	27	28	29	30	31
Block 2	32	33	34	35	36	37	38	39	40	41	42	43	44	45	46	47

### 3. Reader Settings

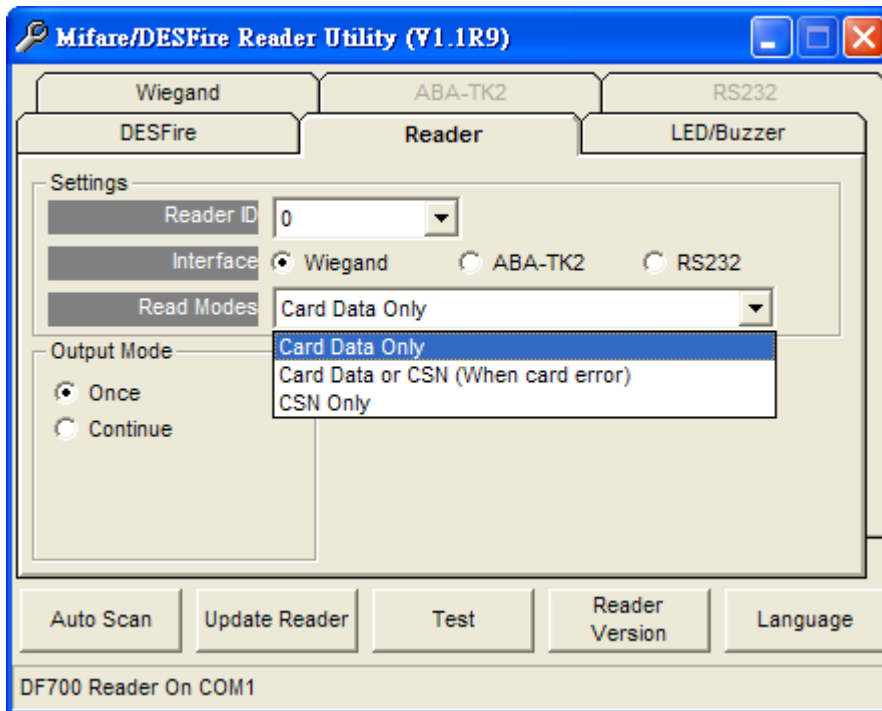

#### **Reader ID : (Default=0)**

DESFIRE Reader ID for multi link application. (ID: 0~99).

#### **Interface : (Default=Wiegand)**

DESFIRE READER can be set as Wiegand , RS232 or ABA-TK2 output.

#### **Read Mode: (Default=Card Data Only)**

- Card Data Only: Read card sector data only; If any error (ex. mifare key error), reader will show "Card Invalid" status.
- Card Data or CSN (Card Serial Number): Read card sector data, If any error (ex. mifare key error), reader will send the CSN to host.
- CSN Only: CSN read only.

#### **Output Mode: (Default=Once)**

- Once: Send data (or CSN) to host once.
- Continue: Keeping sending data (or CSN) to host till card remove.

4. LED / Buzzer Settings

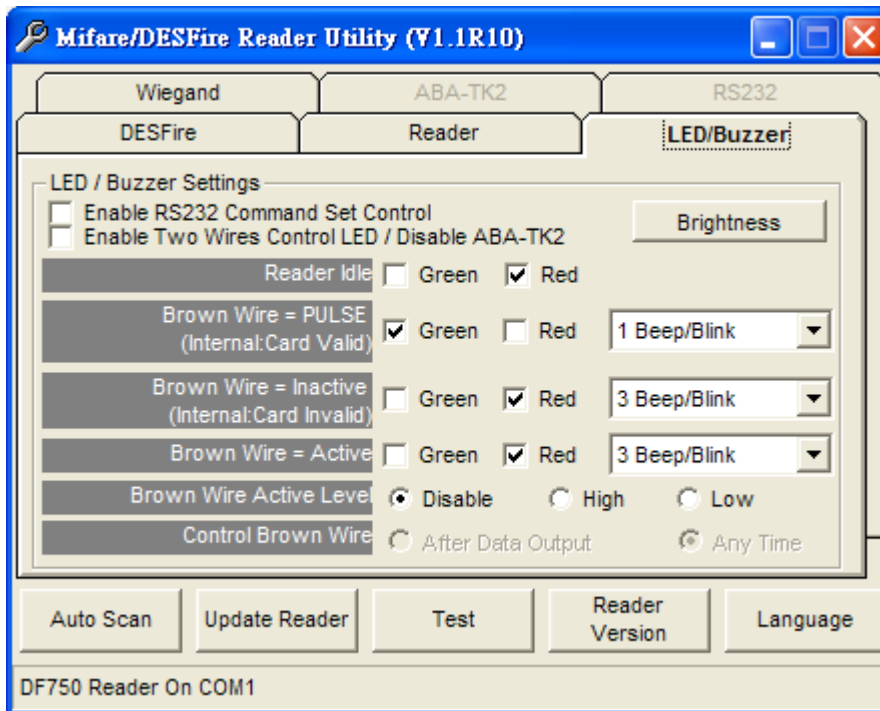

**Enable RS232 Command Set Control: (For 19200,n,8,1 Only)**

RS232 LED/Buzzer command set frame as below:

STX	J	NUMBER (0~9)	CR
02h	4Ah	30h~39h	0Dh

Command Table:

NUMBER	Descriptions
0 (30h)	All LED Off, Buzzer Off
1 (31h)	Green LED ON
2 (32h)	Green LED OFF
3 (33h)	Red LED ON
4 (34h)	Red LED OFF
5 (35h)	Buzzer Beep 1 Time
6 (36h)	Buzzer Beep 3 Time
7 (37h)	Green LED ON with Beep 1 Time
8 (38h)	Red LED ON with Beep 3 Time
9 (39h)	All LED ON (Orange)

**Remark: If Enable the RS232 Command Set Control (for LED/Buzzer), the external LED/Buzzer control with high/low level control will be disable.**

**Enable Two Wires Control LED / Disabled ABA-TK2: (For 19200,n,8,1 Only)**

set up the "Brown Wire Active Level", and Brown wire and Orange wire will follow the setting.

Example: "Brown Wire Active Level"=High; Green light on with a beep when brown wire level high. Red light on with three beeps when orange wire level high. When both wire change level high at the same time, it will both light on without beep.

**Read Idle:** Show LED color after power on or idle state.

**Brown wire = PULSE (or Card is valid):** Show LED color and beeps to indicate the end-user when brown wire = PULSE, or card was passed by DESFIRE Reader.

**Brown wire = Inactive ( or Card Is invalid):** Show LED color and beeps to indicate the end-user when brown wire = Inactive, or card was failed by DESFIRE Reader.

**Brown wire = Active:** Show LED color and beeps to indicate the end-user that brown wire = Active signal from Host.

**Brown wire Active level:** Set Brown wire Active level condition with Host status.

Disable: Always disable the Brown wire. (Default), LED/Buzzer control by reader self.

High: Active High / Normal keep in Low.

Low: Active Low / Normal keep in High.

**Remark:**

**If set Active Low, you may have to connect brown wire to a pull-up resistor (1K~10K) with 5VDC).**

**Control Brown wire:**

After Data Output: The brown wire will be enabling after finished output the card data or CSN. (Default)

Any Time: The brown wire enabled in any time.

**Note:** See Annex E, the LED/Buzzer also can be controlled externally with High/Low level control.

**Brightness:**

Change value to brighten or darken led. More high and more brighten..

## 5. Wiegand Setting:

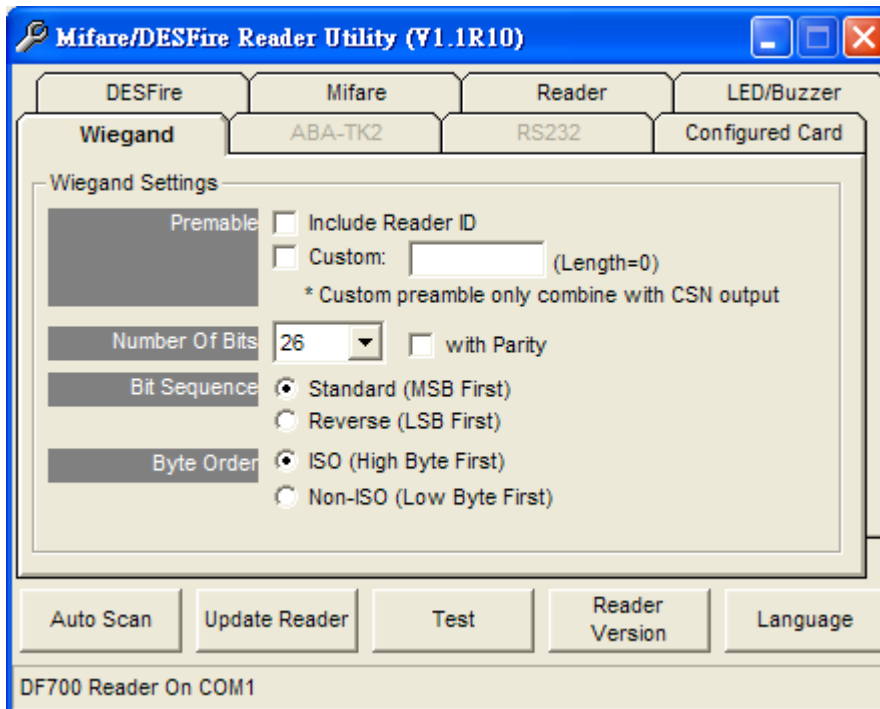

**Include Reader ID** is to set the Wiegand output data to include Reader ID when it is enabled.

(Default=Disable).

**Custom Preamble** is to set the Wiegand output data to include preamble code when it is enabled.

This code only combine with CSN output.

(Default=Disable).

**Number of Bits** is to set the Wiegand output type you want to meet your Host (or Terminal). It can be 1 to 128 (Default=26).

**Bit Sequence** is to set the Wiegand output data sequence, it can be standard data sequence (MSB first) or Reverse data sequence (LSB first). (Default=Standard).

**Byte Order** is to set the Wiegand output data sequence, it can be ISO (High byte first) or Non ISO (Low byte first).

## 6. ABA-TK2 Settings

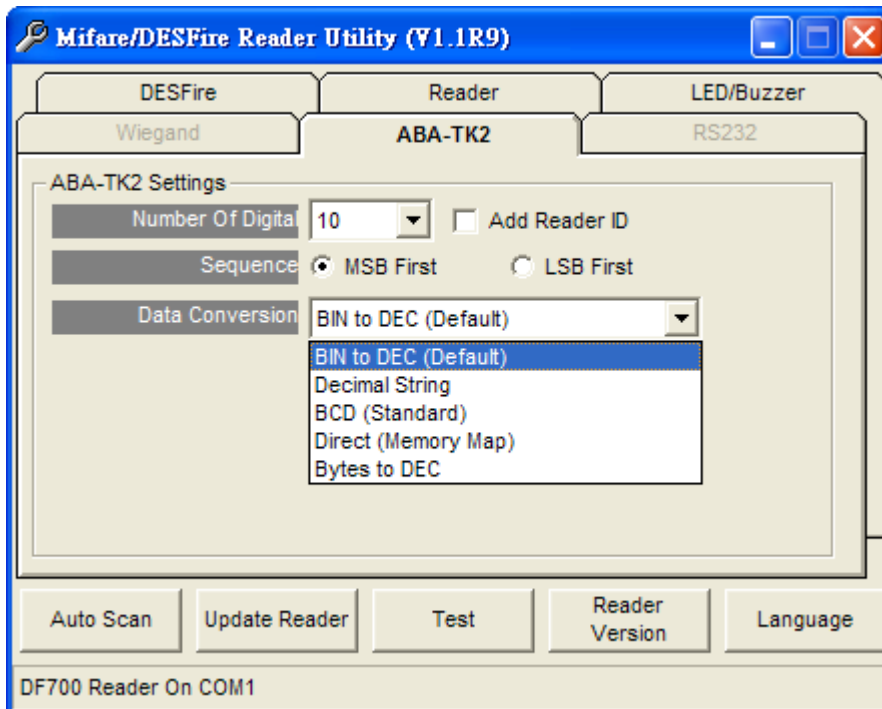

**Number Of Digital:** Set number of digital codes for TK2 output. (Default=10)

**Add Reader ID:** Add Reader ID into TK2 data. (Default=Disable)

**Sequence:** Set the TK2 data sequence. (Default=MSB First)

**Data Conversion:** Select card data format to convert ,

a. BIN to DEC (Default, card issue by Mifare Card Issuer Utility)

b. Decimal String (ex. "123456")

c. BCD

d. Direct (Memory Map)

e. Bytes to DEC

## 7. RS232 Setting:

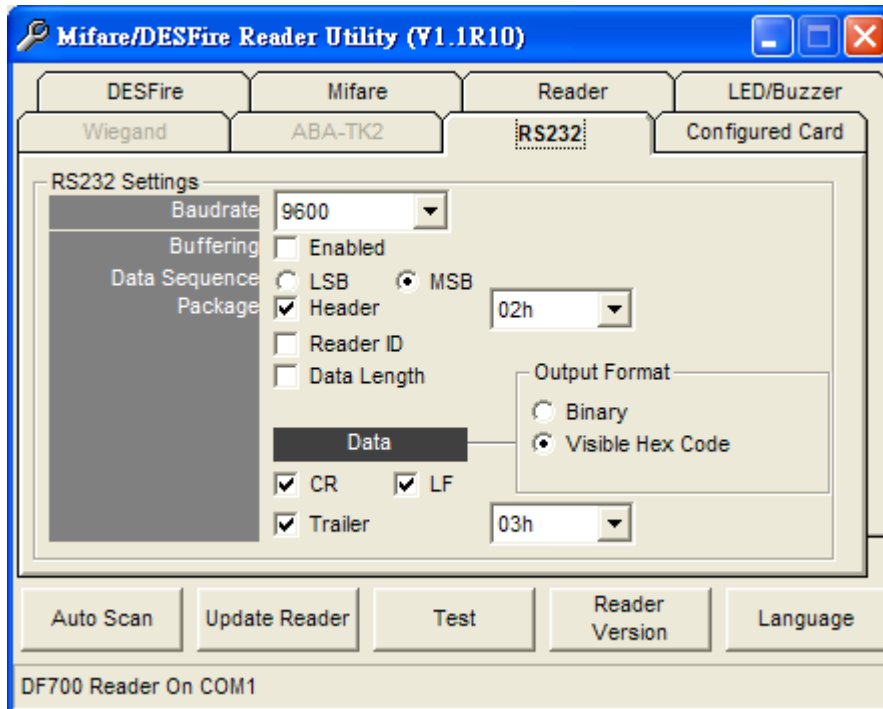

**Baudrate** can be set 2400bps~57600bps (Default=9600bps)

**Data Sequence** can be set "LSB" first and "MSB" first(Default).

**Package**<sup>2</sup> is to set the output data packet to include Header, Reader ID, Data Length, CR, LF and Trailer. (Header:00h~FFh, Trailer : 00h~FFh). (Default = 02h+Visible Hex Code+CR+LF+03h)

**Output Format** can be "Binary" or "Hex String" for output format.

Note:

(1).Wiegand output data packet with Reader ID:

Standard	Parity( <b>Even</b> )	Reader ID	(MSB)	Data Bits	(LSB)	Parity( <b>Odd</b> )
Reverse	Parity( <b>Odd</b> )	Reader ID	(LSB)	Data Bits	(MSB)	Parity( <b>Even</b> )

(2).RS232 output data packet with Header, Reader ID and Trailer:

Header	Reader ID	(LSB)	Data Bytes	(MSB)	Trailer
--------	-----------	-------	------------	-------	---------

(3).ABA-TK2 with Reader ID:

MSB First	SS	Reader ID	(MSB)	Digital Code	(LSB)	ES	LRC
LSB First	SS	Reader ID	(LSB)	Digital Code	(MSB)	ES	LRC

**Remark:**

*DESFire READER all configuration items are write only, so any users can not read the configuration items from DESFire READER to get the **App Key**, that is very important to protect your **App Key** and all configuration items.*

## 8. Configured Card:

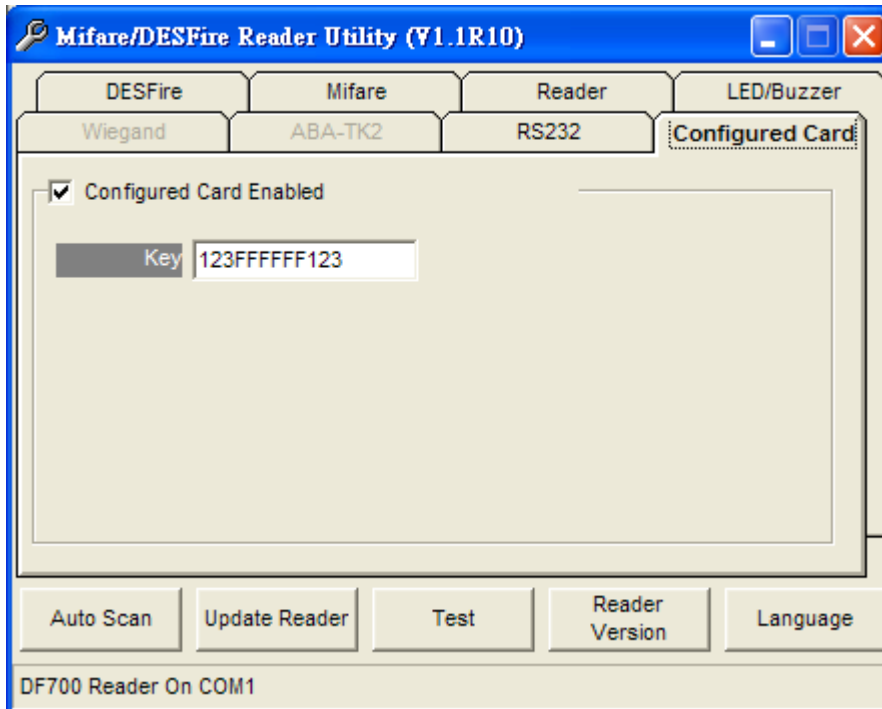

**Configured Card Enabled** can allow your reader change configuration by Mifare Card.

**Key** is the Mifare Key A for allowed configured card.



## 9. Test DESFIRE Reader after configuration

After DESFIRE READER configuration is completed you may use DESFIRE READER Utility “Test” function to test the DESFIRE READER to see if the configuration is done correctly.

1. After the configuration on the DESFIRE READER Utility software is made, you should click [Update Reader] to download the current configuration to the DESFIRE Reader.
2. After DESFIRE READER configuration is completed, you may click [Test] to test DESFIRE Reader.
3. Get an issued mifare<sup>®</sup> card to put on DESFIRE Reader to be read and see the output data on the window of “DESFIRE READER Output Test”.

Wiegand 34 bits output data with standard bit sequence, example as below:

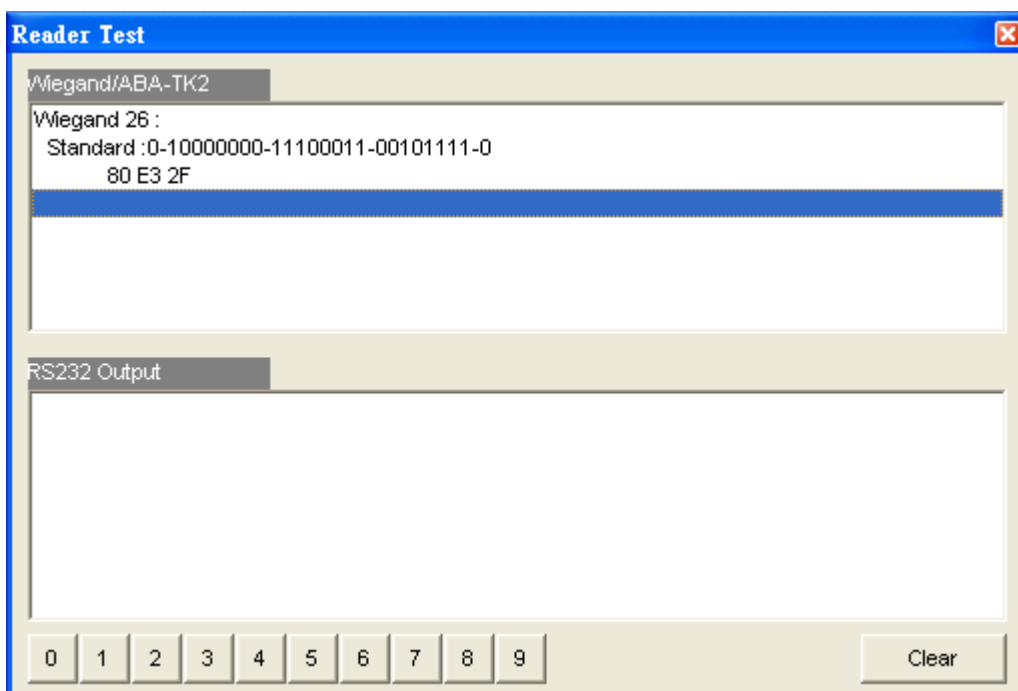

## ANNEX A. Hardware Specification

	DESFIRE READER
<b>Major Feature</b>	Mifare® DESFire Application Directory Reader Access Control & Security
<b>Card Type</b>	ISO14443A, Mifare Class <sup>1</sup> (Mifare® 1K, Mifare® 4K for MAD1/MAD2) DESFire
<b>RF Frequency</b>	13.56MHz
<b>RF Distance<sup>2</sup></b>	50mm (Using the MFA01 Mifare® card of GIGA-TMS INC.)
<b>DC Power</b>	7.5VDC~12VDC (Min 250mA@7.5V, 150mA@12V)
<b>Interface</b>	Wiegand 26~128 bits (Standard / Reverse) RS232 2400bps~57600bps ABA-TK2 40IPS
<b>Dimension</b>	H82.5mm x W46.5mm x D15.0mm
<b>Weight</b>	120g

Note:

1. Mifare Class: Mifare Standard 1K/4K/Pro (without Mifare Ultra-Light).
2. DESFIRE READER RF distance can reach up to 50mm with MFA01 (Mifare® Standard 1K Card) of GIGA-TMS INC.

## ANNEX B. Wiegand Interface

The Data 1 and Data 0 signals are held at a logic high level unit, the reader is ready to send a data stream. The reader places data as asynchronous low-going pulses on the Data 1 or Data 0 lines to transmit the data stream to Host. The Data 1 and Data 0 pulses will allowable pulse width times and pulse interval times for the DESFIRE Reader.

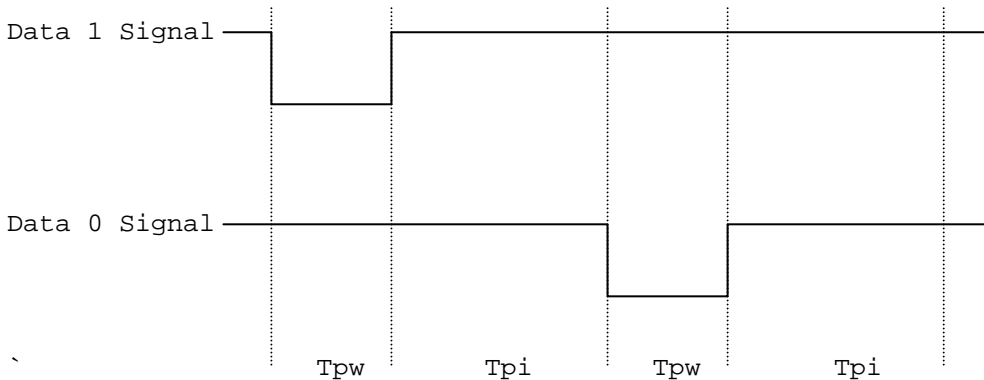

### Pulse Times

Symbol	Description	Typical Time
$T_{pw}$	Pulse Width Time	100us +/- 3%
$T_{pi}$	Pulse Interval Time	1.9ms +/- 3%

### Wiegand Packet (Without Reader ID)

Standard (Default)	Parity(Even)	(MSB)	Data Bits	(LSB)	Parity(Odd)
Reverse (Option)	Parity(Odd)	(LSB)	Data Bits	(MSB)	Parity(Even)

Connect the Wiegand wires, example as below: (The pull high resistor must  $\geq 10K$  Ohm)

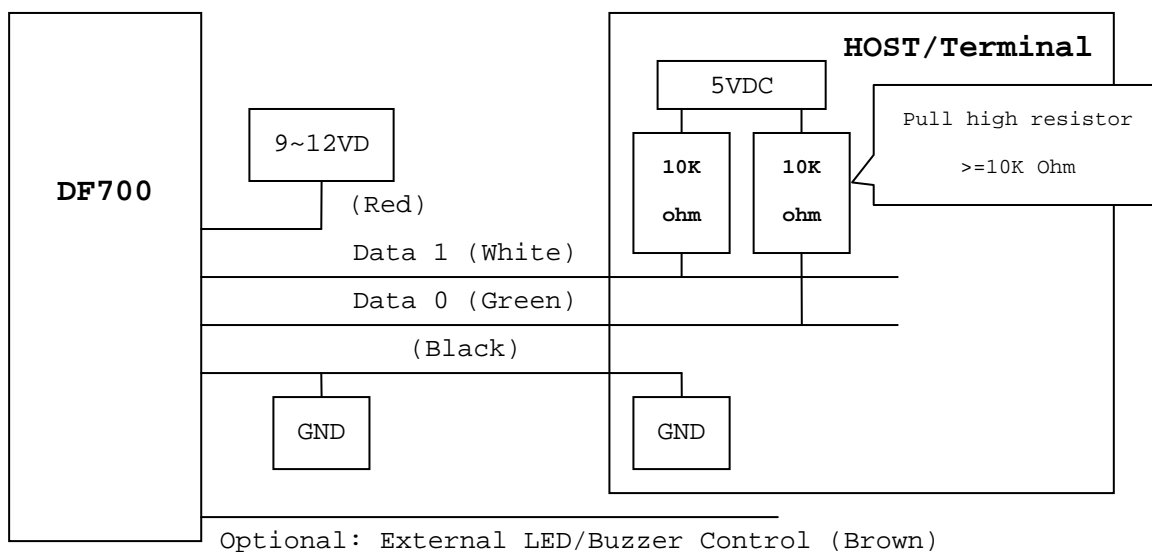

## ANNEX C. ABA TK2 Interface

The timing for Card Present, Clock (Strobe) and Data , example as below:

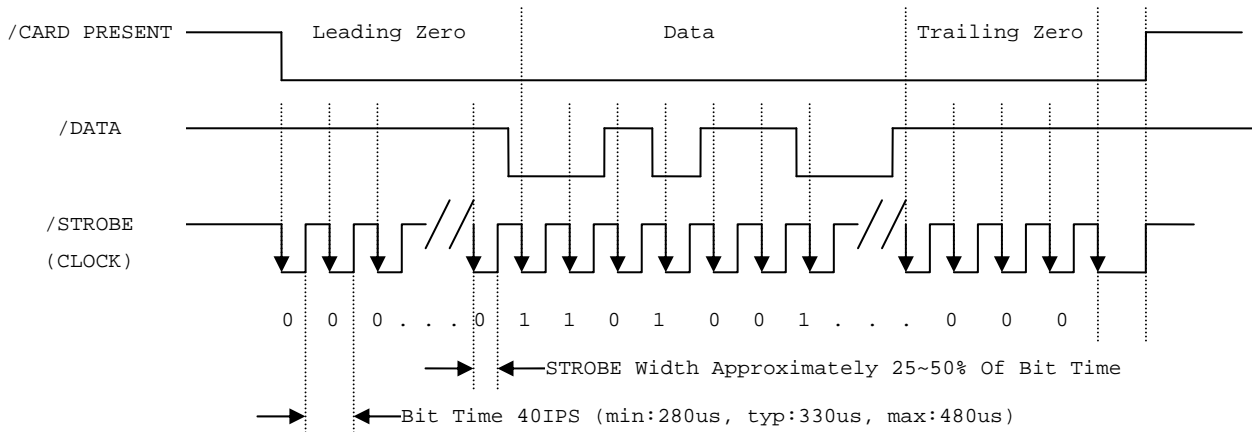

### DATA

The data signal is valid while the clock is low. If the Data signal is high, the bit is a zero. If the Data signal is low, the bit is a one.

### CLOCK (STROBE)

The Clock signal indicates when Data is valid. It is recommended that Data be loaded by the user with the leading edge (negative) of the Strobe.

### CARD PRESENT

Card Present will go low after flux reversals from the Reader. Card Present will return high after the last flux reversal.

Connect the ABA TK2 wires, example as below:

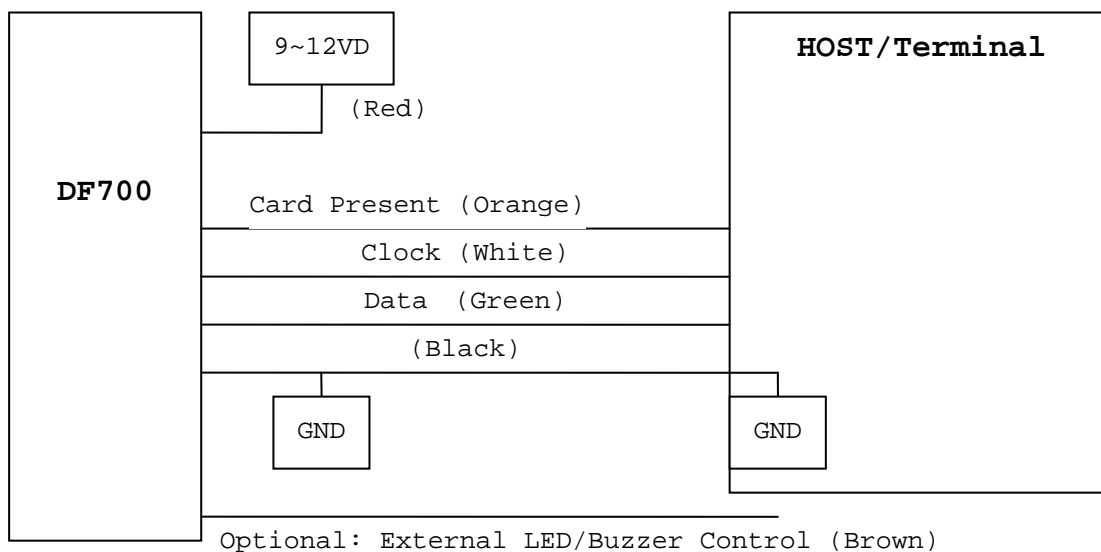

## ANNEX D. RS232 Interface

Connect the RS232 wires, example as below:

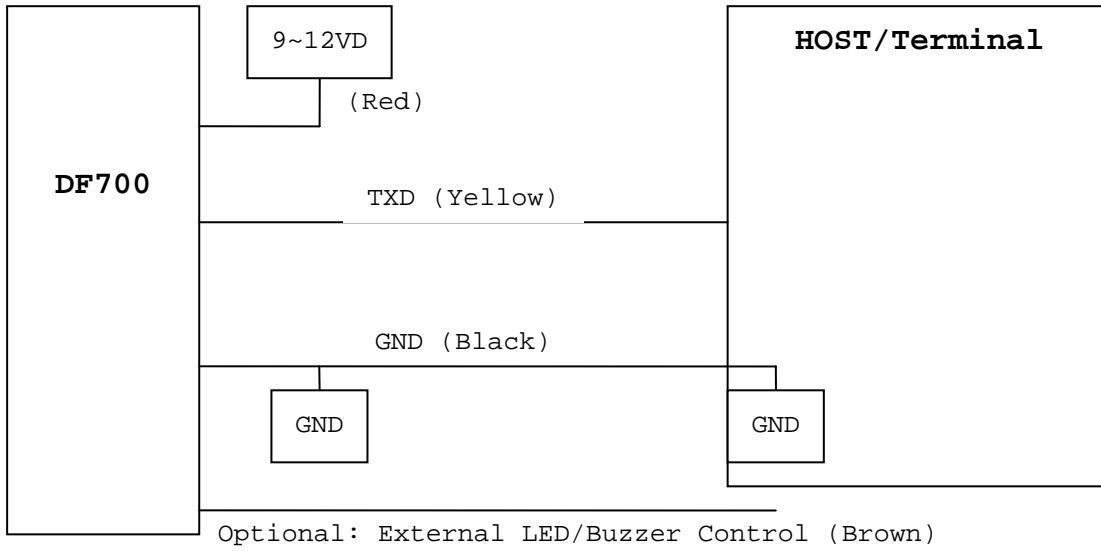

## ANNEX E. External LED/Buzzer Control

DESFIRE READER supports the external LED/Buzzer control for Terminal (or Host) to prompt end-user the card data is invalid or valid. Use `Brown` wire to control the LED/Buzzer of DESFIRE READER

Examples as below: (Active High)

### (1) Show External Invalid Status

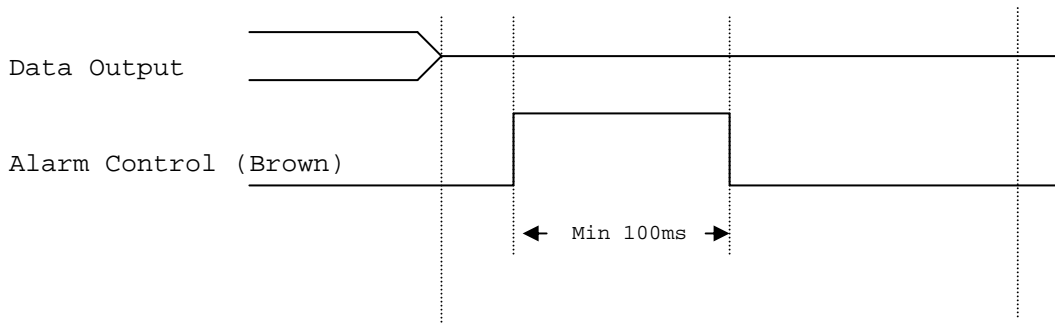

### (2) Show Card Valid Status

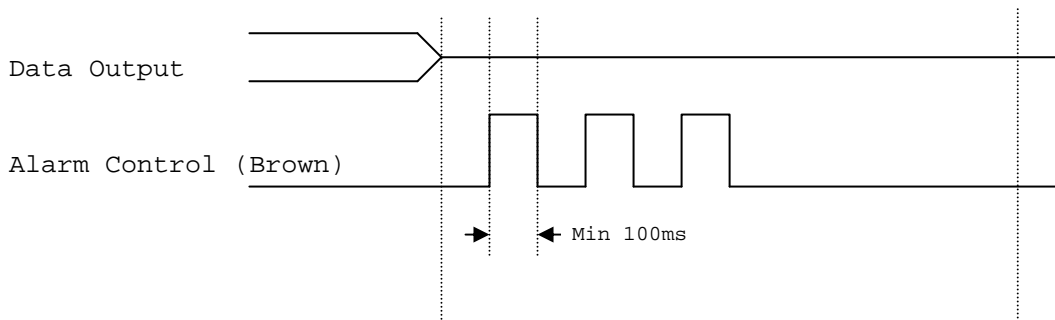

Note:

1. Send one pulse to show the "Extern Invalid" LED/Buzzer Status.
2. Send three or more pulse to show the "Card Valid" LED/Buzzer status.
3. You can configure the LED/Buzzer status by DESFIRE READER utility.

## ANNEX F. Order Information

Part Number	Include	Description
DF700-00	DF700-00	DF700 DESFire Configurable Reader
MF700KIT-10	MF700KIT WAS-T0029 DISK5238 Power Adaptor	Reader Kit MF7XX Configure Cable Card Issue and Utility Software DC Power Adaptor 9VDC for MF7XXKIT
MFA01	MFA01	Mifare® Standard 1K Card
MFA04	MFA04	Mifare® Standard 4K Card

## ANNEX G. WebISP - Firmware Upgrade Utility

DESFIRE READER also supports the ISP (In-System Program) function to upgrade the reader's firmware.

Install the WebISP (include in CD-ROM) in your Windows System first (It may need to reboot your system) and follow the steps as below: (First of all, you need to connect the reader or programmer to PC, and make sure they were power-on)

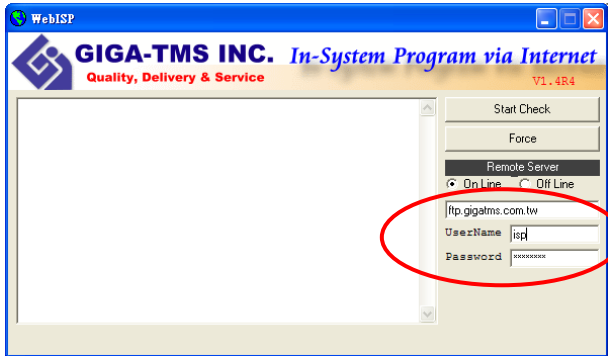
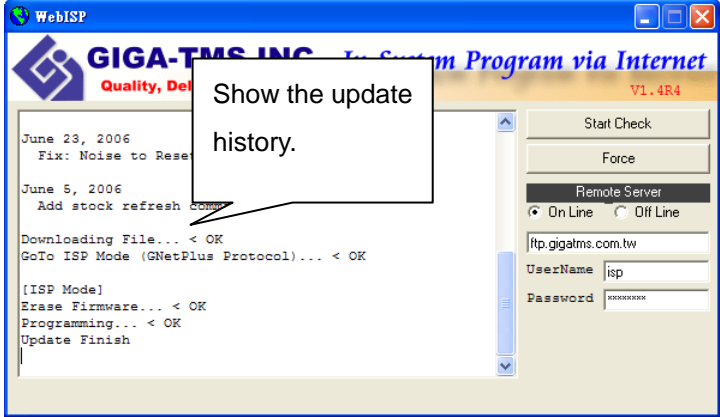
<p><b>Step 1:</b> Input your account (UserName and Password)</p> <p>Note: Contact us to get your account when needed.</p>	
<p><b>Step 2:</b> Click [Start Check] to automatically check the firmware version from our FTP server.</p> <p>Note:</p> <ol style="list-style-type: none"> <li>1. The WebISP will auto scan all Comm ports to search the reader or programmer.</li> <li>2. The WebISP will show the [Update Information] and list the update history.</li> </ol>	

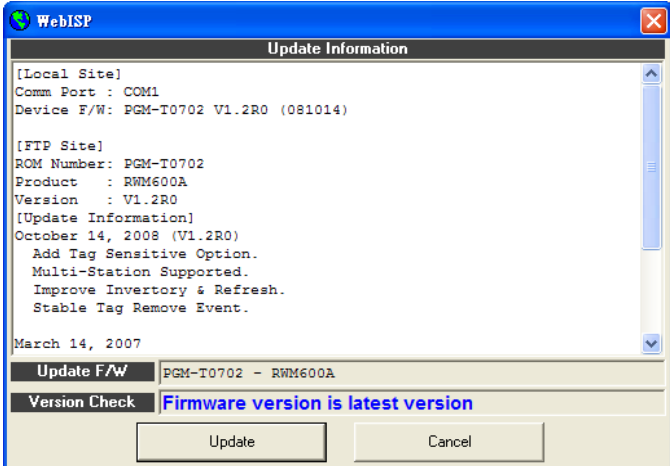
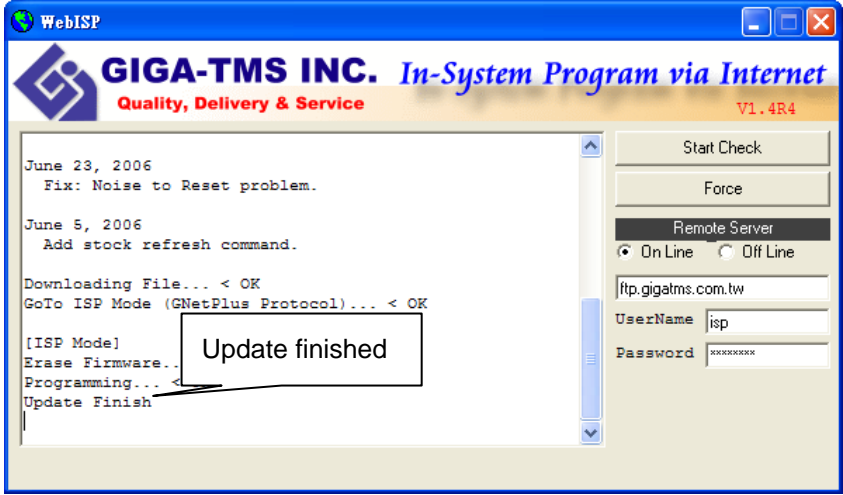

<p><b>Step 3:</b> If your reader's or programmer's firmware out of date, then WebISP will prompt you to update the firmware. Click [Update] to begin Updating the firmware.</p>	 <p>The screenshot shows the 'WebISP Update Information' dialog box. It displays local and FTP site information, including device and ROM numbers. The 'Update F/W' field shows 'PGM-T0702 - RWM600A'. The 'Version Check' field indicates 'Firmware version is latest version'. There are 'Update' and 'Cancel' buttons at the bottom.</p>
<p><b>Step 4:</b> Wait for the updating to finish. And repeat step 2 to update other readers or programmers.</p>	 <p>The screenshot shows the main WebISP interface for GIGA-TMS INC. The log window displays the following text: 'June 23, 2006 Fix: Noise to Reset problem.', 'June 5, 2006 Add stock refresh command.', 'Downloading File... &lt; OK', 'GoTo ISP Mode (GNetPlus Protocol)... &lt; OK', '[ISP Mode] Erase Firmware..', 'Programming... &lt;', and 'Update Finish'. A callout box with the text 'Update finished' points to the 'Update Finish' line. On the right side, there are buttons for 'Start Check', 'Force', and 'Remote Server' settings (On Line/Off Line, ftp.gigatms.com.tw, User Name: isp, Password: *****).</p>

## ANNEX H. Configured Card

You can configure the reader by Mifare Card when the "Configured Card Enabled" is enabled.

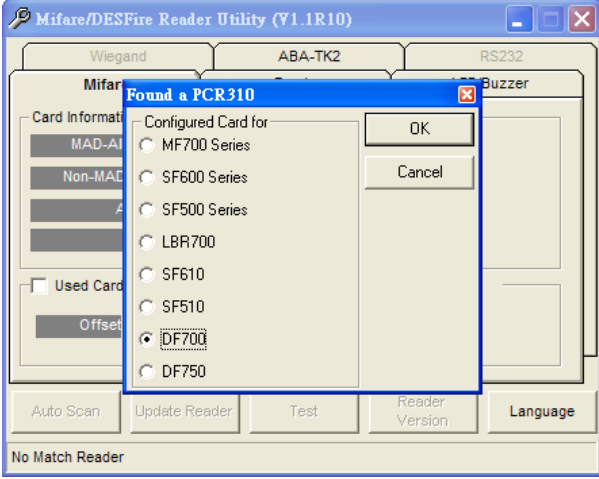
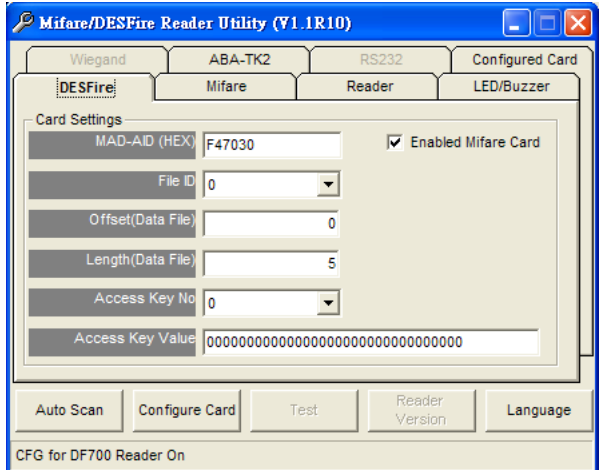
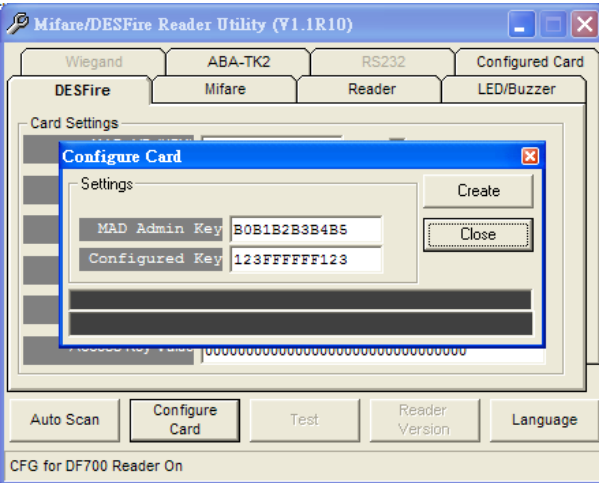
<p><b>Step 1:</b> Connect the PCR310 to PC for issuing card.</p> <p>Click "Auto Scan"</p> <p>Choose "DF700"</p> <p>Click "OK"</p> <p><b>Remark:DO NOT connect the reader to PC.</b></p>	
<p><b>Step 2:</b> Configure all settings as normal.</p> <p>Click "Configure Card"</p>	
<p><b>Step 3:</b> Type in correct "Configured Key" as same as reader configured before.</p> <p>Put a empty Mifare Card.</p> <p>Click "Create"</p> <p>Finish</p> <p>Take this card to approach the readers for configured this settings.</p>	

## **ANNEX I. History**

Rev A: January 19, 2009

Initial DESFire Reader.

# PROMAG<sup>®</sup>

**GIGA-TMS INC.**

<http://www.gigatms.com.tw>

<mailto:promag@gigatms.com.tw>

**TEL : +886-2-26954214**

**FAX : +886-2-26954213**

Office: 8F, No. 31, Lane 169, Kang-Ning St., Hsi-Chih, Taipei, Taiwan