

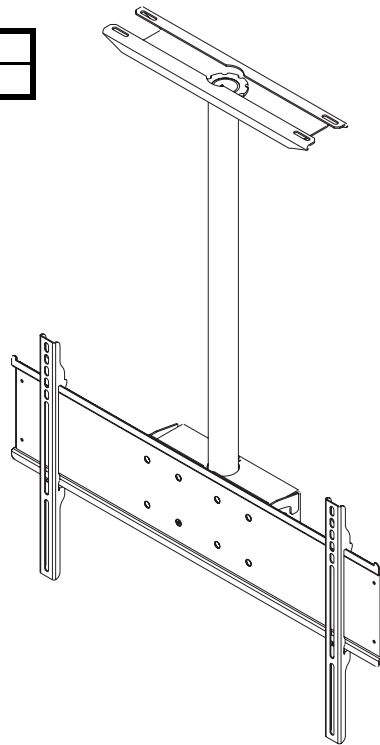

## Installation and Assembly: Straight Column Mount for 32" - 71" Flat Panel Displays

Model	Max. Load	Screen Size Range
PLCM-1CP	225 lb. (102.3 kg.)	32" - 71"
PLCM-UNL-CP	200 lb. (90.7 kg.)	32" - 65"



**NOTE:** Read entire instruction sheet before you start installation and assembly.

### **⚠ WARNING**

- Do not begin to install your Peerless product until you have read and understood the instructions and warnings contained in this Installation Sheet. If you have any questions regarding any of the instructions or warnings, for US customers please call Peerless customer care at 1-800-865-2112, for all international customers, please contact your local distributor.
- This product should only be installed by someone of good mechanical aptitude, has experience with basic building construction, and fully understands these instructions.
- Make sure that the supporting surface will safely support the combined load of the equipment and all attached hardware and components.
- Never exceed the Maximum UL Load Capacity.
- If mounting to wood wall studs, make sure that mounting screws are anchored into the center of the studs. Use of an "edge to edge" stud finder is highly recommended.
- Always use an assistant or mechanical lifting equipment to safely lift and position equipment.
- Tighten screws firmly, but do not overtighten. Overtightening can damage the items, greatly reducing their holding power.
- This product is intended for indoor use only. Use of this product outdoors could lead to product failure and personal injury.

Before you begin, make sure all parts shown are included with your product.

Parts List		PLCM-1CP	PLCM-UNL-CP
Description	Qty	Part #	Part #
<b>A</b> ceiling arm box	1	201-1062	201-1062
<b>B</b> tilt bracket	1	200-1552	200-1552
<b>C</b> 33" support pipe	1	139-1088	139-1088
<b>D</b> retaining collar	1	1800-375	1800-375
<b>E</b> M5 x 10 mm penta-pin™ screw	4	505-9010	505-9010
<b>F</b> .062" fiber washer	1	540-9432	540-9432
<b>G</b> M10 x 15 mm penta-pin screw	8	520-9263	520-9263
<b>H</b> M10 penta-pin tool	1	520-9260	520-9260
<b>I</b> M5 penta-pin tool	1	520-9249	520-9249
<b>J</b> M5 x 8 mm phillips Type F screw	4	520-1167	520-1167
<b>K</b> ceiling plate	1	128-1039	128-1039
<b>L</b> ceiling plate end cap	2	2PT-22CA01D	2PT-22CA01D
<b>M</b> wood screw	4	5S1-015-C03	5S1-015-C03

Parts may appear slightly different than illustrated.

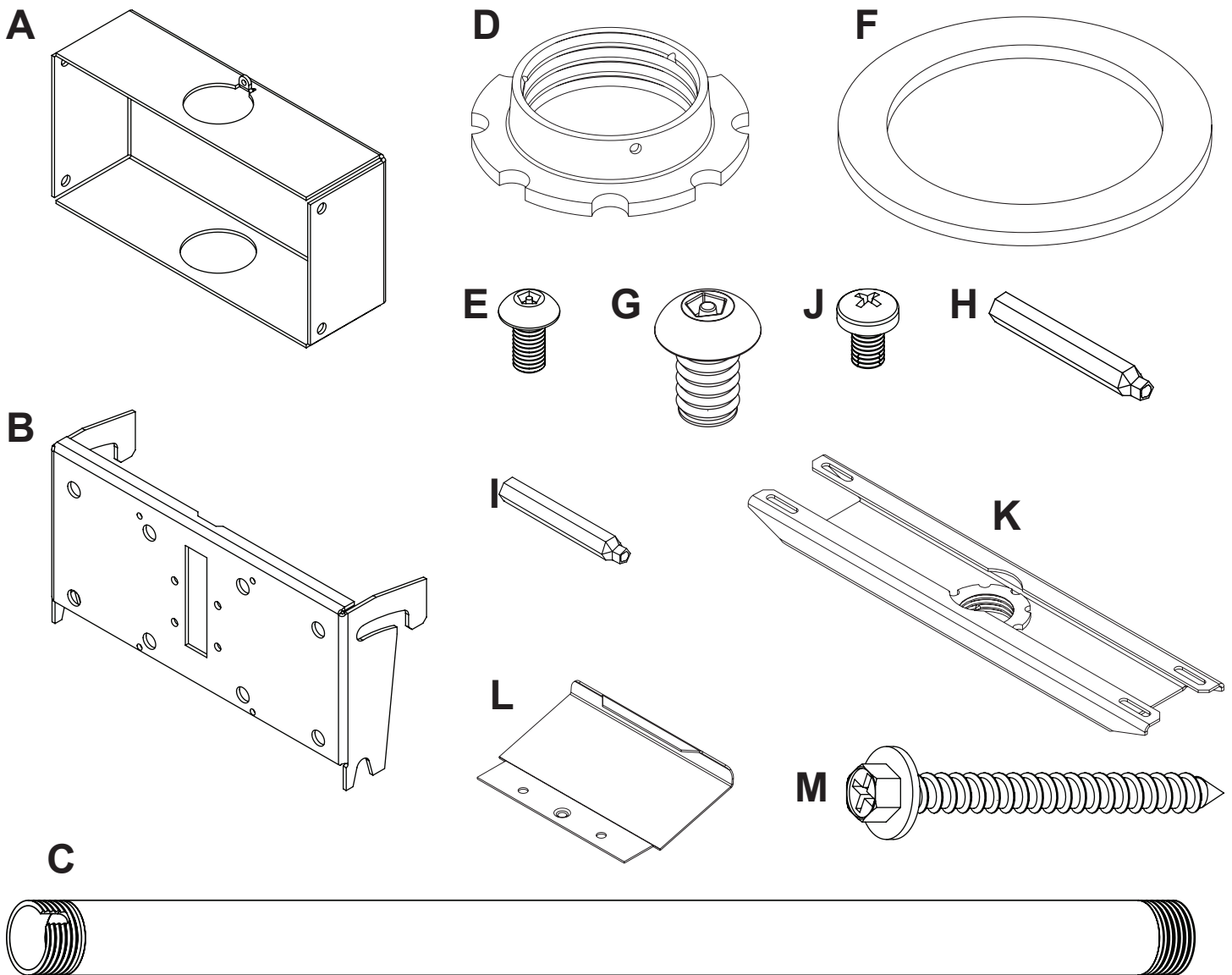

# Parts List

Description	Qty	PLCM-1CP	PLCM-UNL-CP
		Part #	Part #
AA adapter plate	1	-	201-1110
BB shallow vertical brackets	2	-	202-1655
CC M5 x 10 mm socket pin screw	4	-	520-1063
DD M10 x 15 mm socket screws	4	-	520-9262
EE 6 mm allen wrench	1	-	560-9716
FF 4mm allen wrench	1	-	560-9646

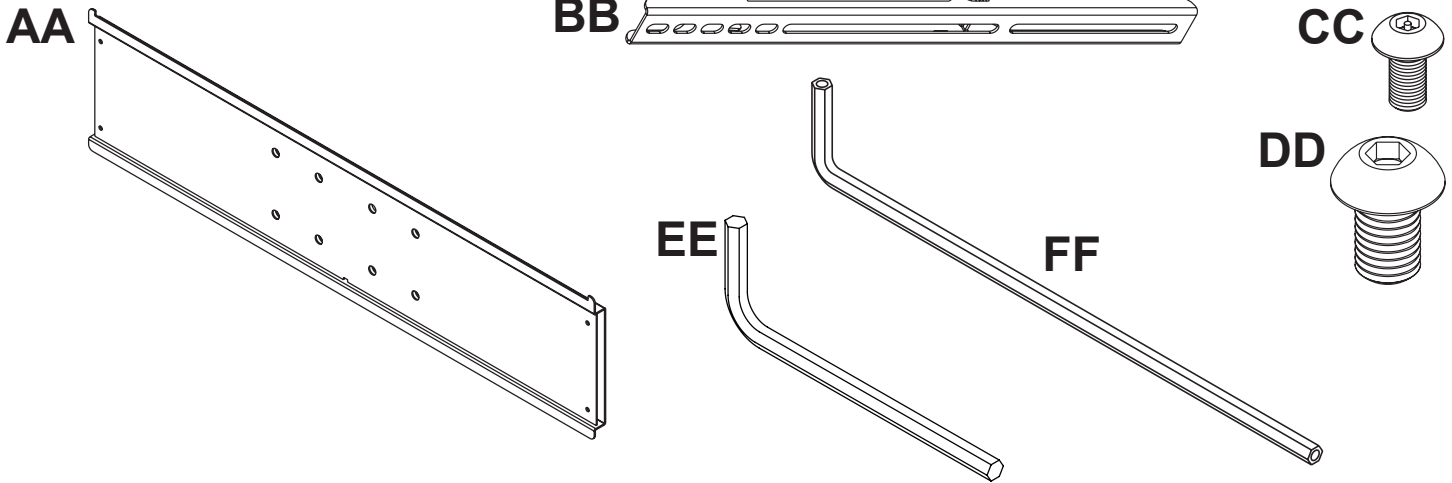

## Security Adapter Bracket Fasteners

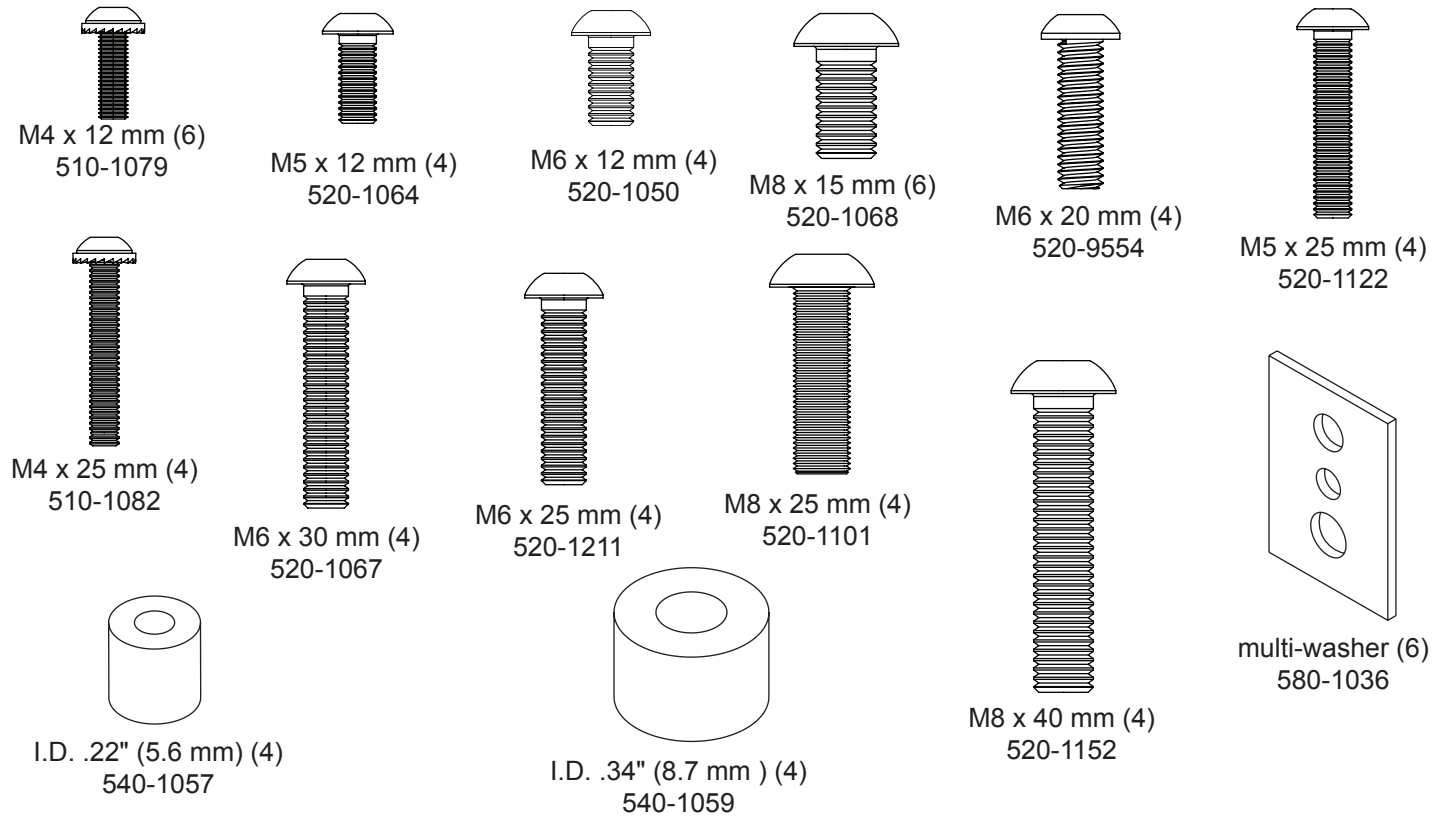

## Installing Adapter Brackets

### ⚠ WARNING

- Tighten screws so adapter brackets are firmly attached. Do not tighten with excessive force. Overtightening can cause stress damage to screws, greatly reducing their holding power and possibly causing screw heads to become detached. Tighten to 40 in. • lb (4.5 N.M.) maximum torque.
- If screws don't get three complete turns in the display inserts or if screws bottom out and bracket is still not tightly secured, damage may occur to display or product may fail.

- 1 To prevent scratching the display, set a cloth on a flat, level surface that will support the weight of the display. Place display face side down. If display has knobs on the back, remove them to allow the adapter brackets to be attached. Place adapter brackets (**BB**) on back of display, align to holes, and center on back of display as shown below. Attach the adapter brackets to the back of the display using the appropriate combination of screws, multi-washers and spacers as shown in step 1-1 and step 1-2.

**NOTE:** Top and bottom holes on display must always be used.

Verify that all holes are properly aligned, and then tighten screws using a phillips screwdriver.

**NOTE:** Tighten using security allen wrench (**FF**).

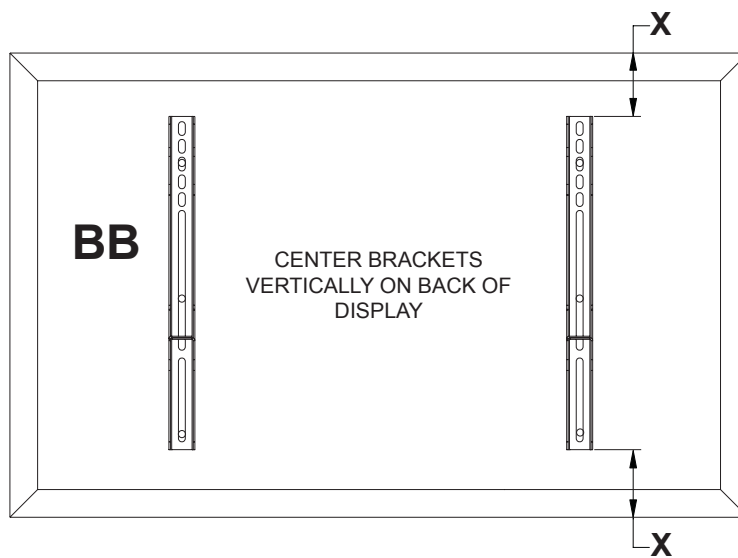

**Note:** "X" dimensions should be equal.

#### Notes:

- The number of fasteners used will vary, depending upon the type of display.
- Multi-washers and spacers may not be used, depending upon the type of display.
- Use the corresponding hole in the multi-washer that matches your screw size as shown.

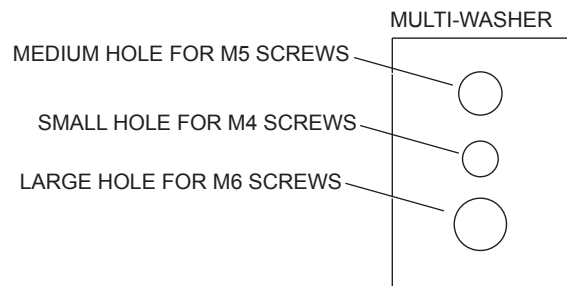

**NOTE:** For **flat back displays** proceed to step 1-1. For **bump-out or recessed back display** skip to step 1-2.

## For Flat Back Display

**1-1** Begin with the shortest length screw, hand thread through multi-washer and adapter bracket into display as shown below. Screw must make at least three full turns into the mounting hole and fit snug into place. Do not over tighten. If screw cannot make three full turns into the display, select a longer length screw from the baffled fastener pack. Repeat for remaining mounting holes, level brackets and tighten screws.

**NOTE:** Spacers may not be used, depending upon the type of display.

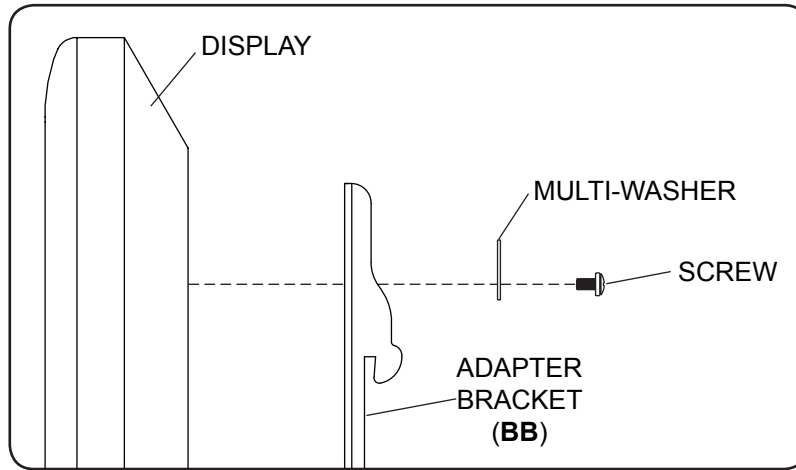

If you have any questions, please call Peerless customer care at **1-800-865-2112**.

---

## For Bump-out or Recessed Back Display

**1-2** Begin with longer length screw, hand thread through multi-washer, adapter bracket and spacer in that order into display as shown below. Screw must make at least three full turns into the mounting hole and fit snug into place. Do not over tighten. If screw cannot make three full turns into the display, select a longer length screw from the baffled fastener pack. Repeat for remaining mounting holes, level brackets and tighten screws.

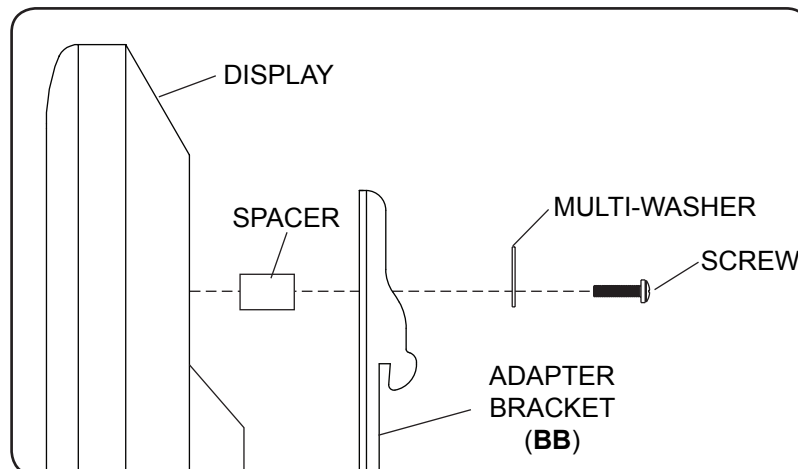

If you have any questions, please call Peerless customer care at **1-800-865-2112**.

- 2 For Wood Joist Finished Ceiling, Exposed Wood Joists, or Wood Beam Ceiling.** Drill four 5/32" (4 mm) dia. holes to a minimum depth of 2.5" (64 mm) **INTO JOIST CENTERS**. Attach ceiling plate (**K**) with four wood screws (**M**) using a 3/8" (10 mm) socket wrench. Tighten wood screws (**M**) so ceiling plate is firmly attached. Snap end caps (**L**) into place.

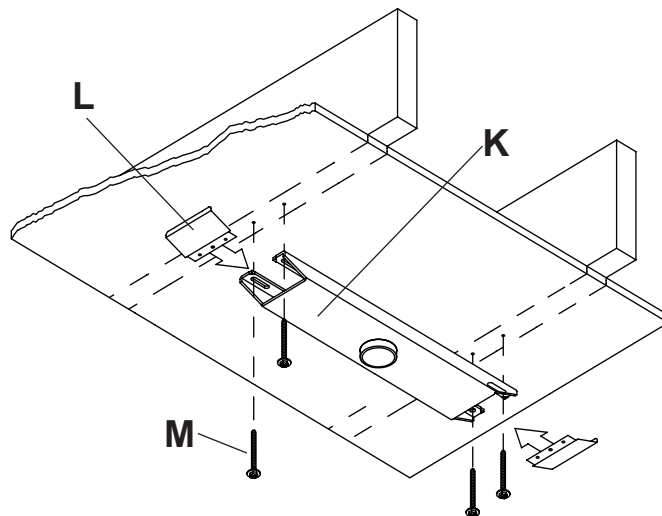

## ⚠ WARNING

- Tighten wood screws so that ceiling plate is firmly attached, but do not overtighten. Overtightening can damage screws, greatly reducing their holding power.
- Never tighten in excess of 80 in • lb (9 N.M.).
- Make sure that mounting screws are anchored into the center of the joists. The use of an "edge to edge" stud finder is highly recommended.

- 2 For Concrete Ceilings** drill four 5/16" (8 mm) dia. holes to a minimum depth of 1 3/4" (45 mm). Attach ceiling plate (**K**) using concrete expansion anchors as shown in 2-1 and 2-2. Then snap end caps (**L**) into place.

Align hole in ceiling plate with hole in ceiling.  
Gently hammer in concrete anchor.

Use a 10 mm wrench to tighten concrete anchor to 80 in • lb (9 N.M.) maximum torque to expand anchors.

**FOR PRODUCT SAFETY USE ONLY RAWL™ #5005 OR HILTI™ HL814 CONCRETE ANCHORS.**  
Order accessory kit **#ACC210** which contains four .312 x 1.625 concrete expansion anchors.

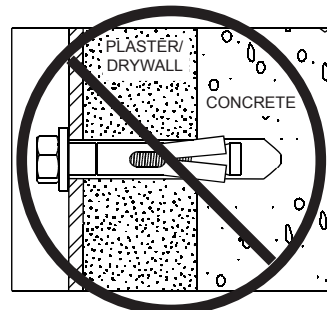
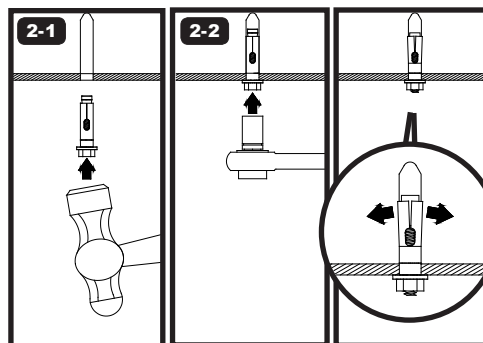
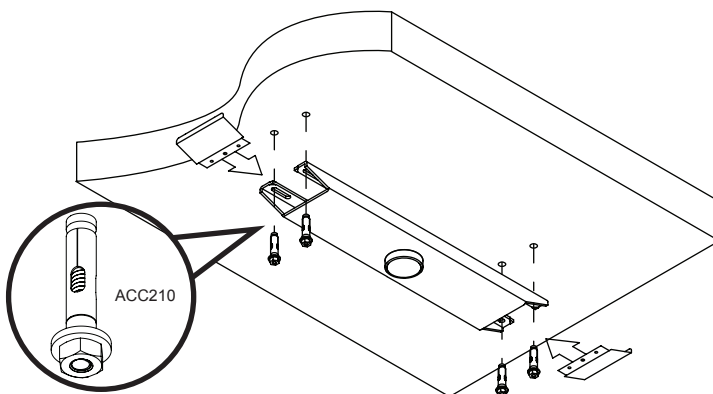

## ⚠ WARNING

- Always attach concrete expansion anchors directly to load-bearing concrete.
- Never attach concrete expansion anchors to concrete covered with plaster, drywall, or other finishing material.

## Installing Adapter Bracket

- Using the hole pattern shown below, attach adapter plate (AA) to tilt bracket (B) with four M10 x 15 mm screws (G). Tighten screws using M10 penta-pin tool (H).

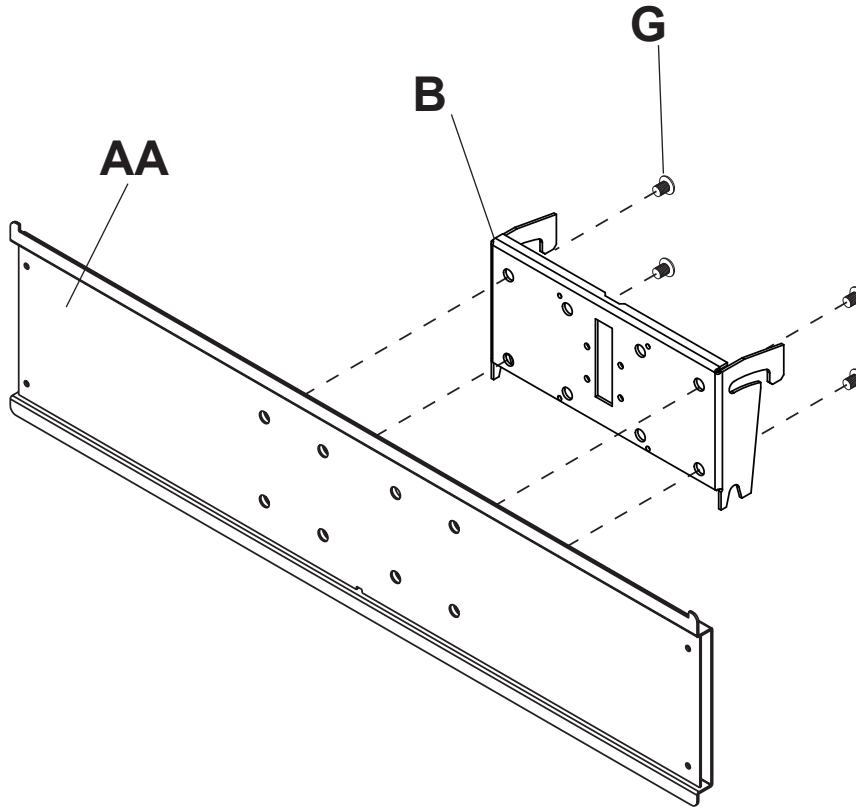

**4** Thread support pipe (C) into threaded fitting in ceiling plate (K). Align with one small hole in the side of the ceiling plate threaded fitting. Insert and tighten one M5 x 10 mm penta-pin screw (E) as shown. Tighten screw using M5 penta-pin tool (I). Insert four M10 x 15 mm penta-pin screws (G) into threaded holes in the sides of ceiling arm box (A). Leave approximately 1/4" of exposed thread. Slide ceiling arm box (A) and fiber washer (F) onto end of support pipe. Thread retaining collar (D) onto support pipe. Allow ceiling arm box (A) to rest on top of retaining collar (D). Insert and tighten one M5 x 10 mm penta-pin screw (E) into retaining collar (D) as shown. Insert one M5 x 10 mm penta-pin screw (E) through the tab on the back of ceiling arm box (A). Use M5 penta-pin tool (I) to tighten screws. Do not over tighten.

**Note:** UL Listed AEC or EXT extension column series can be used in combination with, or in place of support pipe (C) to achieve different lengths.

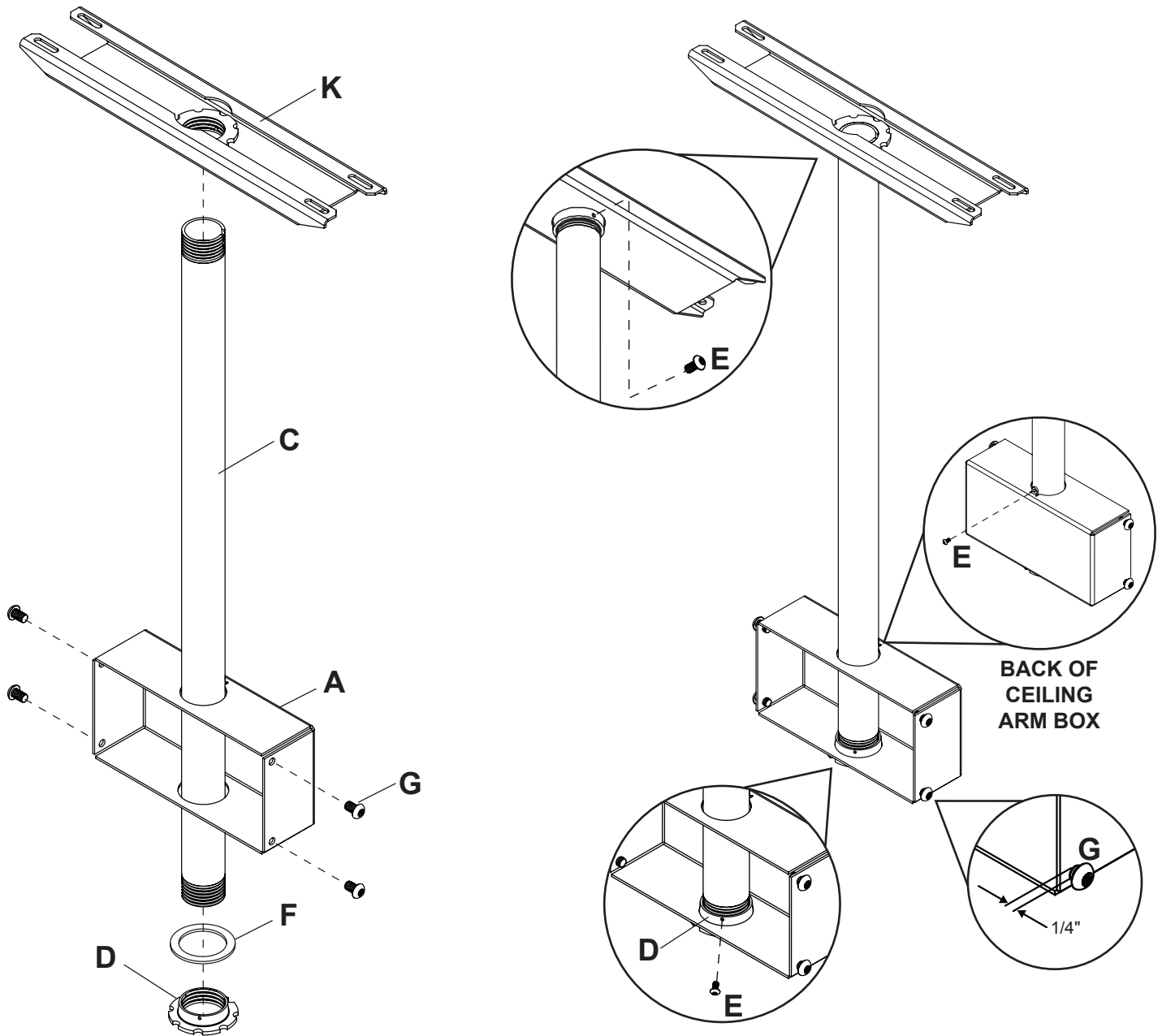



- 5** Hang tilt bracket (**B**) onto ceiling arm box (**A**). Adjust tilt as desired and tighten four M10 x 15 mm penta-pin screws (**G**) using M10 penta-pin tool (**H**).

**⚠ WARNING**

- For a safe assembly be sure to fully tighten four screws (**G**).

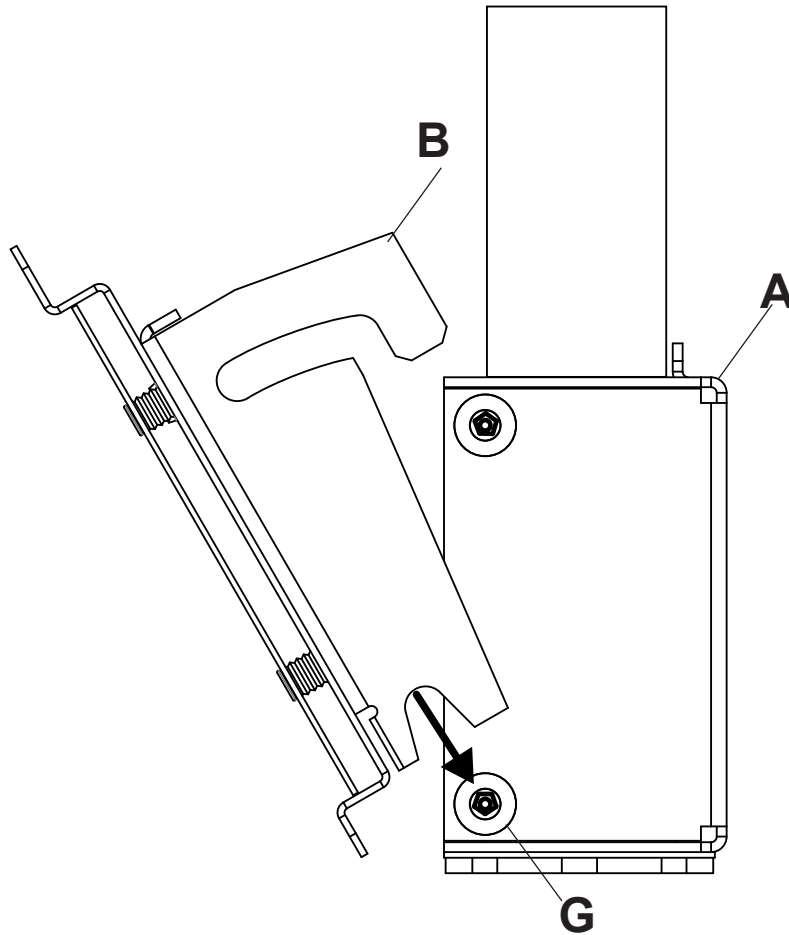

## Mounting and Removing Flat Panel Display

### ⚠ WARNING

- Always use an assistant or mechanical lifting equipment to safely lift and position the plasma television.

**6** Hook adapter brackets (**BB**) onto universal PLP plate (**AA**), then slowly swing display in as shown. Turn safety/security screws clockwise at least six times to prevent display from being removed as shown in detail 1. Tighten all fasteners using wrench (**FF**).

Display can be adjusted horizontally if desired as shown in figure 6.1.

**NOTE:** To lock the display down, tighten safety/security screws to adapter bracket as shown in detail 1.

To remove display from mount, loosen safety/security screws, swing display away from mount, and lift display off of mount.

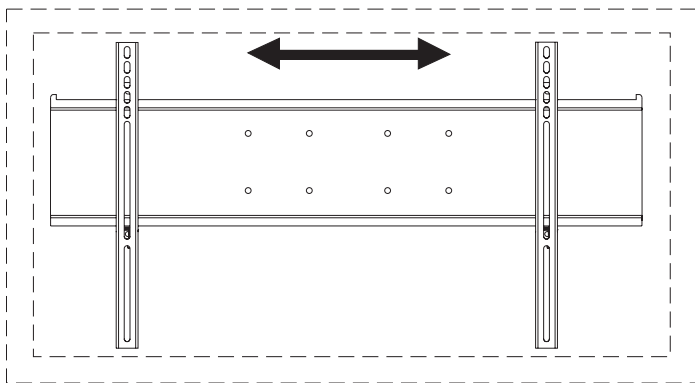

Fig. 6.1

