



3-5800CR.090-1

Rev. H 3/06

English



CAUTION!

- Refer to instruction manual for more details.
- Remove power to unit before wiring input and output connections.
- Follow instructions carefully to avoid personal injury.

Contents

1. Power Connections
2. Compatible Sensor Wiring
3. 4 - 20 mA Current Output Connections
4. Relay Connections
5. Relay Operation
6. Menu Functions
7. Parts Per Million (PPM) Factor
8. Temperature Coefficient
9. Parts and Accessories
10. Specifications
11. Quick Reference Menu Parameters
12. Troubleshooting
13. Maintenance

Remove terminal blocks for easy wiring

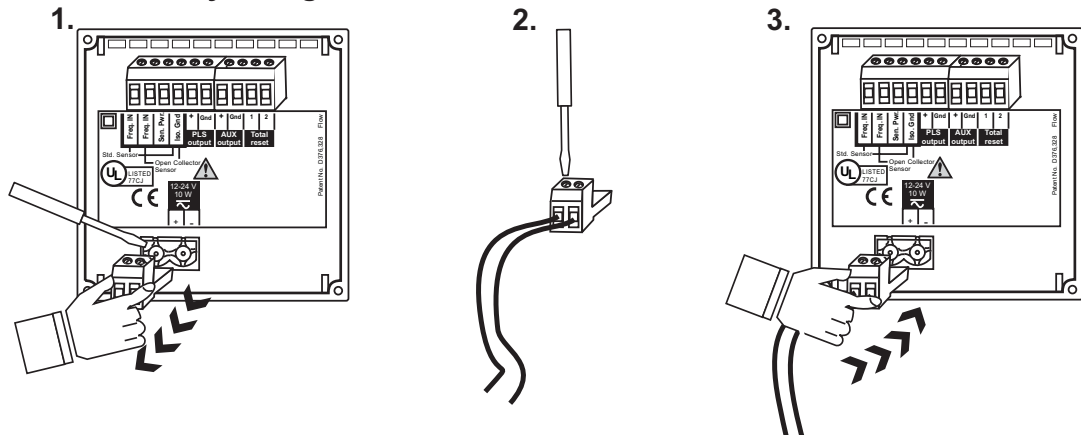

1. Power Connections



CAUTION!

Never connect 110 VAC or 220 VAC to rear power terminals. High voltage AC will damage instrument and void warranty.

- = Double Insulated
- = DC or AC power

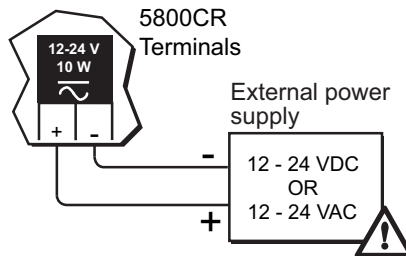

Technical Notes:

- To reduce the possibility of noise interference, isolate AC power lines from signal lines.
- Maximum 4-20 mA loop impedance (sec. 3) is affected by the supply voltage.

2. Compatible Sensor Wiring

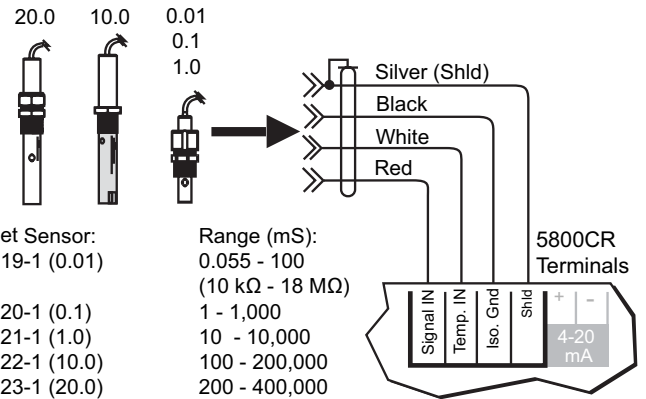

Technical Notes:

- ★ Resistivity measurements within the 10 MΩ to 18 MΩ range must be performed in solution temperatures from 20°C to 100°C.
- Use three conductor shielded cable for cable extensions up to 30 m (100 ft) max.
- Cable shield **MUST** be maintained through cable splice.

3. 4-20 mA Current Output Connections

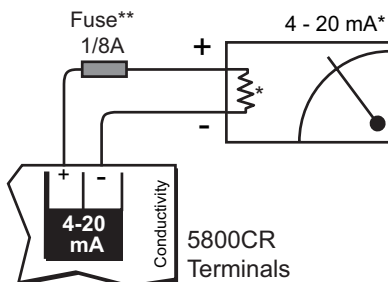

To isolate output and prevent ground loop problems:

1. Use monitor device with isolated inputs, or
2. Use separate DC supply for 5800CR and monitor device, or
3. Power 5800CR with 12 - 24 VAC step down transformer

Technical Notes:

- ** 1/8A fuse recommended (customer supplied)
- * 4-20 mA output is internally powered (non-isolated), maximum loop impedance 350 Ω with a 12 V instrument supply voltage, 950 Ω with a 24 V instrument supply voltage.

4. Relay Connections

Two internal relay contact sets (COM, NO, and NC) may be used for external device control. Front panel LED annunciators indicate the activation status of each relay. Each relay can control up to two devices simultaneously, as shown. Relay operation modes include Low alarm, High alarm, and Proportional Pulse (sec. 5).

Common device connections include:

- Pulse mode - metering pump control
- Pulse mode - solenoid valve control
- Low or High mode - warning lamps
- Low or High mode - bells or sirens
- Low or High mode - external heavy-duty relay

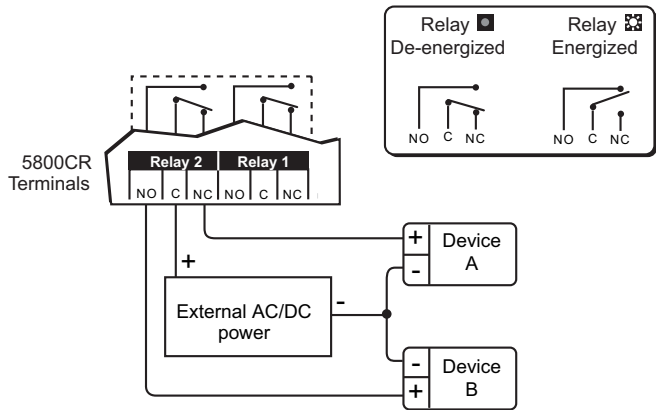

Wiring Example Right

Device A IS powered when relay 2 is de-energized (front panel LED "off"). Power is discontinued when the relay 2 setpoint is reached (front panel LED "on"). Device B IS NOT powered when the relay 2 is de-energized. Power is applied after the relay 2 setpoint is reached.

Technical Notes:

- Maximum relay contact ratings: 5 A @ 30 VDC, 5 A @ 125 VAC, or 3 A @ 250 VAC
- An external heavy-duty relay must be used for devices with surge currents or operating currents that exceed the above specifications.

5. Relay Operation

A. LOW alarm mode

The relay is energized when the solution conductivity (mS) drops below the setpoint, and is de-energized when the solution conductivity rises above the setpoint plus hysteresis (sec. 6.2F, 6.2G).

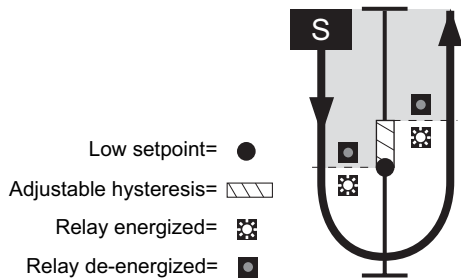

B. HIGH alarm mode

The relay is energized when the solution conductivity (mS) rises above the setpoint and is de-energized when the solution conductivity falls below the setpoint plus hysteresis (sec. 6.2F, 6.2G).

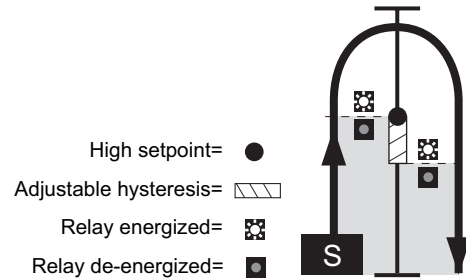

C. Proportional PULSE mode

The proportional pulse relay configuration is primarily designed for metering pump control. The operator is prompted to enter a minimum and maximum conductivity setpoint and maximum pulse rate for the assigned relay (sec. 6.2H, 6.2I). Relay pulse width is fixed at 130 ms. Refer to the operation examples below.

- Metering pump chemical addition (dry contact activation type required)

Example 1 (right):

As the process conductivity (S) rises above the minimum pulse setpoint (10 S) the relay begins pulsing; triggering the metering pump for deionized water addition. As the process conductivity continues to rise, pulsing accelerates proportionally until the maximum programmed pulse rate of 300 pulses/minute and setpoint (90 S) are reached, forcing the process conductivity back down to intended levels (e.g. 10 S).

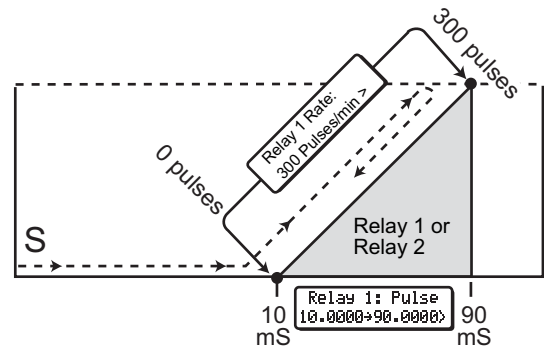

Example 2 (right):

As the process conductivity falls below the minimum pulse setpoint (90 S) the relay begins pulsing; triggering the metering pump for chemical addition. As the process conductivity continues to decrease, pulsing accelerates proportionally until the maximum programmed pulse rate of 300 pulses/minute and setpoint (10 S) are reached, forcing the process conductivity back up to intended levels (e.g. 90 S).

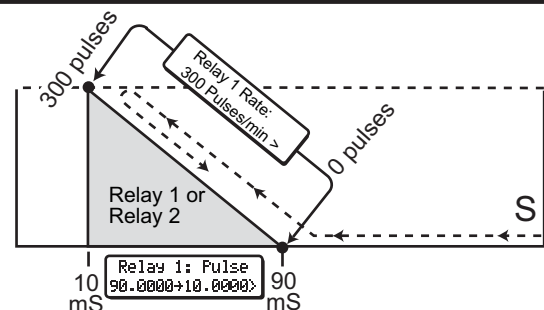

6. Menu Functions

To access either CALIBRATE or OPTIONS menus, press and hold the ENTER key as illustrated below:

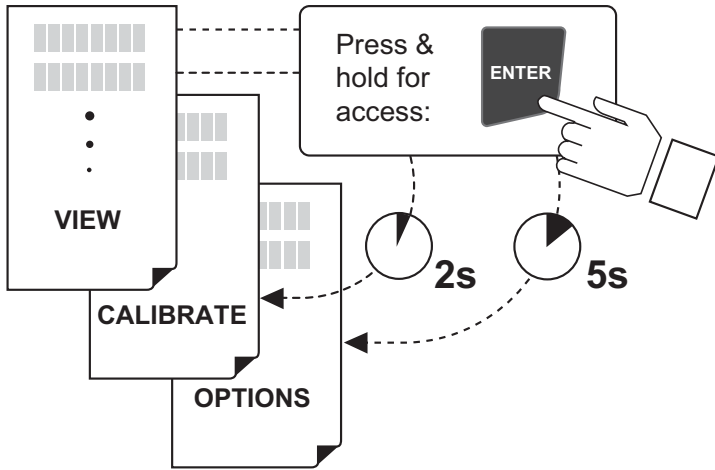

Menus:

- VIEW menu (sec. 6.1): The VIEW menu is displayed during standard operation. The operator can navigate freely through the menu by pressing either UP or DOWN arrow keys.
- CALIBRATE Menu (sec. 6.2): The CALIBRATE menu contains all critical display setup and output parameters. A simple security code feature prevents unauthorized tampering. The operator is required to enter a simple access code for menu access. The same code also unlocks OPTIONS menus.
- OPTIONS Menu (sec. 6.4): The OPTIONS menu contains setup and display features that are seldom accessed for minor display or output adjustments.
- Reversible Dials
The 5800CR includes a dial kit with 6 reversible dial faces and units decals (factory installed dial: 0 - 100). See dial kit for additional information.

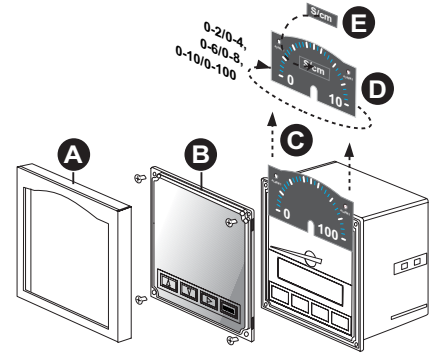

6.1 VIEW Menu

1	2	3
Choose:	Change:	Save:
<p>0.0 uS/cm +25.0 °C Cond./temp.</p> <p>Loop Output: 20.00 mA Loop output</p> <p>Min→Max: uS/cm 0.0000→100.000 Range</p> <p>Relay 1: Low 10.0000 uS/cm Relay 1</p> <p>Relay 2: High 90.0000 uS/cm Relay 2</p> <p>Last CAL: 01-01-98 Last calibration</p>		

Menu Displays A - F:
(Factory default displays shown in menu column 1)

- A. Active display of conductivity, resistivity, or PPM (TDS) and Temperature in degrees Celsius (°C) or Fahrenheit (°F).
- B. Loop output display: shows the loop current output level.
- C. Range display: shows the programmed min and max meter dial range (sec. 6.2D).
- D. Relay 1 display: shows the programmed operation mode and setpoint for relay 1 (sec. 6.2F).
- E. Relay 2 display: shows the programmed operation mode and setpoint for relay 2 (sec. 6.2F).
- F. Last calibration: shows a user defined setup date for maintenance records. This feature is not an internal timer or calender.

6.2 CALIBRATE Menu

Requirements

System calibration (Step E, WET CAL) is required for first-time system setup or periodic sensor verification. System calibration can be performed with with a solution of know conductivity and an accurate thermometer, or with fixed resistors. Refer to the WET CAL procedure (sec. 6.3) for calibration details.

CALIBRATE: ---- Enter Key Code		Press keys in sequence to continue, ***** will appear during code entry.	
1 Choose:		2 Change:	
A. Cell#: Standard 1 >	Cell#: Standard .01 .1 1 10 20 Cell type	Cell: Custom 01.0200 Cell value	
Sensor			
B. Units: uS >	Units: uS mS PPM kΩ MΩ	Units: uS mS PPM kΩ MΩ*	
Units	Measured units		
Shown only with PPM units selected above			
C. PPM Factor: 2.00 >	PPM Factor: 2.00 Factory default: 2.00	PPM Factor: 1.95	
PPM Factor			
D. Min→Max: uS/cm 0.0000+100.000 >	Min→Max: uS/cm 00.0000+100.000 Meter Min→Max	Min→Max: uS/cm 00000.0+00400.0	
Range			
E. WET CAL: >	WET CAL: Press <ENTER> key to access Press <ENTER> WET CAL procedure (sec. 6.3); System calibration "Please Wait" briefly displays		
Wet Calibration			
Relay Low or High Mode Selected			
F. Relay 1: Low 10.0000 uS/cm >	Relay 1: Low 10.000 uS/cm Mode Setpoint	Relay 1: Low 100.000 uS/cm	
Relay			
G. Relay 1 Hys: 1.0000 uS/cm >	Relay 1 Hys: 01.0000 uS/cm Hysteresis	Relay 1 Hys: 00200.0 uS/cm	
Relay			
Relay Pulse Mode Selected, Step F			
H. Relay 1: Pulse 10.0000+90.0000 >	Relay 1: Pulse 10.0000+90.0000 Mode Range	Relay 1: Pulse 0070.0+00095.0	
Relay			
I. Relay 1 Rate: 120 Pulses/min >	Relay 1 Rate: 120 Pulses/min Pulse rate	Relay 1 Rate: 025 Pulses/min	
Relay			
J. Last CAL: 01-01-98 >	Last CAL: 01-01-98 Optional	Last CAL: 02-05-98	
Last calibration			
To return to VIEW:	To restore original value:		
quick press	quick press		

Menu Settings A - J:

(Factory default displays shown in menu column 1)

- A. Selects cell type and cell value:
 - Standard cells: 0.01, 0.1, 1.0, 10.0, or 20.0
 - Custom (certified) cells: 00.0000 - 999999.
 See section 2 for recommended cell constant and operation range
 - B. Selects displayed conductivity units;
 - ★ Solution temperatures limited from 20°C to 100°C for measurements from 10 MΩ to 18 MΩ.
 - C. Sets PPM factor when PPM display units are selected (step B), 0.01 - 9.99. Refer to section 7 for feature explanation.
 - D. Sets Min →Max meter dial range (factory installed dial, 0 - 100). Contact factory for custom dial configurations. Does not effect 4 to 20 mA output
 - E. Selects WET CAL procedure for first time system setup or periodic system recalibration (sec. 6.3).
- Menu items F - I repeat for relay 2 setup.
- F. Sets relay operation mode Low or High, and setpoint, 00.0000 - 999999. units (sec. 5).
 - G. Sets relay hysteresis, 00.0000 - 999999. units (sec. 5). Set to zero to disable feature
 - H. Sets relay minimum and maximum pulse setpoint, 00.0000 - 999999. units (sec 5).
 - I. Sets relay pulse rate, 000 - 300 pulses/minute (sec. 5).
 - J. Sets user defined setup date for maintenance records. This feature is not an internal timer or calender

"SAVING" briefly displays

6.3 WET CAL Procedure

Requirements

Electronic calibration is performed to exacting standards by Signet. System calibration will reduce errors which may be caused by sensor wire lengths longer than the standard fifteen feet length. Wire lengths of 100 feet are acceptable; cable shield must be maintained through cable splice. Calibration may be done by known solution value (A), or by resistance simulation (B).

A) Calibration with NIST Traceable Solutions:

When using calibration standards traceable to the National Institute of Standards and Technology (NIST), care must be taken to ensure the sensor and test solution are at the solution temperature specified on the test solution label. Care must be taken to prevent contamination of the calibration solution. It is recommended to thoroughly rinse the sensor in a small amount of test solution (then discard) before placing in any test solution for calibration purposes. The two step WET CAL process first allows for verification or calibration of temperature, followed by verification or calibration of either conductivity, resistivity, or PPM (TDS) using a known process solution.

B) Optional Verification with Precision Resistors:

The use of precision resistors ($\pm 0.1\%$) connected to the rear "Temp In", "Signal IN", and "Iso Gnd" terminals in place of the *GF* SIGNET sensor, will yield quick and accurate electronic instrument calibration. The WET CAL procedure allows for verification or calibration of temperature, followed by conductivity, resistivity, or PPM (TDS) utilizing precision resistors. Calibration is completed as follows:

- 1) Select a standard cell constant based on desired range of operation (sec. 10, Fig. 1).
- 2) Place a 1096 Ω TC resistor between "Temp IN" and "Iso Gnd" terminals as shown. Note: Temperature simulation errors can adversely effect calibration: 3.85 ohms = 1°C error.
- 3) Calculate the required simulation resistor that represents a value within the selected cell range (sec. 10, Fig. 1). The formula for determining the required simulation resistance is:

$$\text{Resistance} = \frac{\text{Cell}}{\text{Desired conductivity (Siemens*)}} ; \quad \text{e.g.} \quad \frac{0.1}{0.000020 \text{ (Siemens*)}} = 5,000 \text{ or } 5 \text{ k}$$

*Conversion: 1 S = 1×10^{-6} Siemens or 0.000001 Siemens

$$\text{Conductivity} = \frac{\text{Sensor cell}}{\text{Simulation resistance (Ohms)}} ; \quad \text{e.g.} \quad \frac{0.1}{100,000} = 0.000001 \text{ Siemens*} \quad \text{or} \quad \boxed{1 \text{ S/cm}}$$

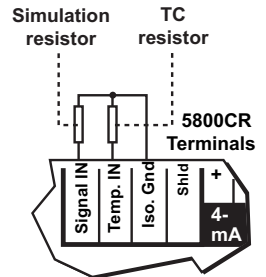

- 4) Place the calculated simulation resistance between the "Signal IN" and "Iso Gnd" terminals as shown.
- 5) Perform WET CAL Procedure below, setting temperature to 25.0 °C and conductivity to the calculated value, step 3.

WET CAL Procedure (Solution Calibration Illustrated below)

1	2	3
Display:	To Change:	To Accept:
<p>Temperature: +25.7 °C ></p> <p>A) Solution cal.: place sensor and thermometer into standard solution then press right arrow key.</p> <p>B) Resistor verification: press right arrow key.</p>	<p>Temperature: +25.0 °C</p> <p>A) Solution cal.: allow approx. 3 minutes for stabilization, then enter solution temperature*</p> <p>B) Resistor verification: enter 25.0 C on display.</p>	<p>Press ENTER to accept temperature calibration.</p> <p>Temperature: +25.0 °C</p>
<p>★ Conductivity: 10017.3 uS/cm ></p> <p>Measured conductivity shown after temperature calibration</p>	<p>Conductivity: 10000.0 uS/cm</p> <p>Enter known solution conductivity or calculated conductivity.</p> <p>Optional: enter zero to reset factory calibration (zero MUST be re-entered if to reset factory calibration).</p>	<p>Conductivity: 1000.0 uS/cm</p> <p>Press ENTER to accept conductivity calibration; display returns to CALIBRATE MENU in 3 seconds (sec. 6.2E)</p>
<p>To exit WET CAL at any time without saving changes:</p> <p>▲ ▼ quick press</p>		

*IMPORTANT:
Always match test solution manufacturer's temperature recommendation.

Conductivity units are displayed as selected in the CALIBRATE menu (sec. 6.2B).

★ Resistivity displayed when k Ω or M Ω ranges are selected (sec. 6.2B).

6.4 OPTIONS Menu

OPTIONS: ---- Enter Key Code		Press keys in sequence to continue, *** will appear during code entry.	
1	2	3	
Choose:	Change:	Save:	
A. Contrast: 3 >	Contrast: 1 2 3 4 5	Contrast: 1 2 3 4	 "SAVING" briefly displays
Contrast	Low ----- High		
B. Display Decimal: ***** >	Display Decimal: Display Decimal: *****	Display Decimal: *****	
Conductivity	Display decimal		
C. Display Average: Low >	Display Average: Display Average: Off Low High	Display Average: Off Low High	
Averaging	0s 4s 8s		
D. Set 4 mA: 0.0000 uS/cm >	Set 4 mA: 00.0000 uS/cm	Set 4 mA: 02000.0 uS/cm	
Loop output	Set 4 mA		
E. Set 20 mA: 100.000 uS/cm >	Set 20 mA: 100.000 uS/cm	Set 20 mA: 120.000 uS/cm	
Loop output	Set 20 mA		
F. 4 mA Adjust: 4.00 mA >	4 mA Adjust: 4.00 mA	4 mA Adjust: 3.88 mA	
Loop output	4 mA adjust		
G. 20 mA Adjust: 20.00 mA >	20 mA Adjust: 20.00 mA	20 mA Adjust: 19.98 mA	
Loop output	20 mA adjust		
H. Temperature: °C >	Temperature: °C °F	Temperature: °C °F	
Temp. display	C or F		
I. Temperature Comp %: 2.00 >	Temperature Comp %: 2.00	Temperature Comp %: 1.81	
Temp. comp %	Factory default: 2.00		
To return to VIEW:	To restore original value:		
quick press	quick press		

Menu Settings A - I:

(Factory default displays shown in menu column 1)

- A. Selects LCD display contrast: 5 levels
- B. Selects display decimal:
..... to
- C. Selects LCD display averaging:
Off = 0 seconds, Low= 4 seconds, High= 8 seconds (also effects 4 - 20 mA output)
- D. Sets 4 mA output setpoint. 4 mA and 20 mA setpoints are reversible.
- E. Sets 20 mA output setpoint. 20 mA and 4 mA setpoints are reversible.
- F. Sets 4 mA current output: 3.0 to 5.0 mA (overrides 4.00 mA factory calibration)
- G. Sets 20 mA current output: 19 to 21 mA (overrides 20.00 mA factory calibration)
- H. Selects temperature display: °C or °F
Recalibration is not required when switching from Celsius to Fahrenheit.
- I. Selects temperature compensation % (coefficient), see section 8 for feature explanation.

7. Parts Per Million (PPM) Factor

This feature is only applicable when PPM display units are selected (sec. 6.2B).

The 5800CR is capable of displaying total dissolved solids (TDS) in parts per million (PPM) units. This is done by dividing the actual solution conductivity in μS by the programmed parts per million factor (sec. 6.2C).

$$\text{TDS (PPM)} = \frac{\text{Solution conductivity } (\mu\text{S})}{\text{PPM Factor}}$$

Example:

- PPM Factor = 2.00 (factory default)
- Solution conductivity = 400 μS
- TDS (PPM) = $\frac{400 \mu\text{S}}{2.00 \text{ PPM Factor}} = 200 \text{ PPM}$ on the display

The programmable PPM Factor is adjustable from 0.01 to 9.99 (factory default = 2.00). You can determine the best PPM Factor for your process solution if you know the solution's conductivity (μS) and the percent of total dissolved solids (PPM), see example below:

$$\text{PPM Factor} = \frac{\text{Solution conductivity } (\mu\text{S})}{\text{Total dissolved solids (PPM)}}$$

Example:

- Solution conductivity = 400 μS
- TDS = 200 PPM (mg/L)
- PPM Factor = $\frac{400 \mu\text{S}}{200 \text{ PPM}} = 2.00$

8. Temperature Coefficient (Temp. Comp. %)

Conductivity measurement is highly dependent on temperature. Temperature dependence is usually expressed as the relative change per $^{\circ}\text{C}$, commonly known as percent/ $^{\circ}\text{C}$ change from 25 $^{\circ}\text{C}$, or slope of the solution.

Slopes can vary significantly depending on process solution type. The factory default temperature compensation factor is 2.00%/ $^{\circ}\text{C}$. This setting satisfies many general applications. Your process solution may require adjustment for maximum accuracy. The following procedure can be used to determine the optimum temperature compensation factor for your process. This procedure can be used when published references are not available.

★ Do not use this procedure for solutions from 0.055 μS to 0.1 μS (10 M Ω to 18 M Ω). An internal pure water curve is used for these ranges. The factory default setting of 2.00%/ $^{\circ}\text{C}$ should be used.

Equipment Required

- 5800CR monitor and 28XX-1 series conductivity sensor
- Process solution samples (2)
- Temperature source

Procedure

1. Disable the 5800CR's temperature comp % factor by entering 0.00 (sec. 6.4l).

2. Heat the sample solution close to the maximum process temperature. Place sensor in the sample solution (allow several minutes for stabilization). Access the VIEW menu (sec. 6.1A) and record the displayed temperature and conductivity values in the spaces provided below:

Sample Solution (Step 2)

Displayed temperature:

T1= _____ $^{\circ}\text{C}$

Displayed conductivity:

C1= _____ μS

3. Cool the sample solution close to the minimum process temperature. Place sensor in the sample solution (allow several minutes for stabilization). Record displayed temperature and conductivity values in the spaces provided below:

Sample Solution (Step 3)

Displayed temperature:

T2= _____ $^{\circ}\text{C}$

Displayed conductivity:

C2= _____ μS

A 10% change in conductivity between steps 2 and 3 is required for optimum performance. If necessary, increase maximum (step 2) and reduce minimum (step 3) sample temperatures. This will result in a larger change in conductivity between steps.

4. Substitute recorded readings (steps 2 and 3) into the following formula:

$$\text{TC Slope} = \frac{100 \times (C1 - C2)}{(C2 \times (T1 - 25)) - (C1 \times (T2 - 25))}$$

Example:

A sample solution has a conductivity of 205 μS @ 48 $^{\circ}\text{C}$. After cooling the solution, the conductivity was measured at 150 μS @ 23 $^{\circ}\text{C}$. Therefore: C1 = 205, T1 = 48, C2 = 150, T2 = 23. The TC is calculated as follows:

$$\text{TC Slope} = \frac{100 \times (205 - 150)}{(150 \times (48 - 25)) - (205 \times (23 - 25))} = \frac{5500}{3860} = 1.42\%/^{\circ}\text{C}$$

9. Parts and Accessories

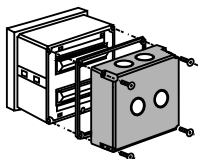

Splashproof rear cover
#3-5000.395
(code 198 840 227)

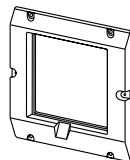

5 x 5 inch adapter plate
for Signet retrofit
#3-5000.399
(code 198 840 224)

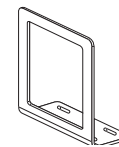

Optional surface
mount bracket #3-
5000.598
(code 198 840 225)

- Power supply, 120 VAC - 24 VAC, #3-5000.075
- Front snap-on bezel, #3-5000.525 (code 198 840 226)
- Assorted conductivity unit/multiplier decal sheet, #3-5500.611 (code 198 840 231)
- 5800CR Conductivity Monitor Instruction Sheet, #3-5800CR.090-1 (code 198 869 916)

10. Specifications

General

Compatible sensors: Signet 3-28XX-1 Standard and Certified Series Sensors (Figure 1)

Accuracy: $\pm 2\%$ of reading

Input range: 0.055 to 400,000 μS (10 k Ω to 18 M Ω ★), optically isolated

★ Resistivity/conductivity measurements from 10 M Ω to 18 M Ω (0.055 μS to 0.1 μS) must be performed in solution temperatures from 20°C to 100°C.

Enclosure:

- NEMA 4X/IP65 front
- Dimensions: 1/4 DIN, 96 x 96 x 88 mm (3.8 x 3.8 x 3.5 in.)
- Case materials: ABS plastic
- Keypad material: Sealed 4-key silicone rubber
- Weight: 500 g (18 oz.)

Display:

- Type: Microprocessor controlled air-core meter movement and backlit alphanumeric 2 x 16 LCD
- Update rate: <2s
- Contrast: User selected
- Relay annunciators: 2 LEDs
- Displayed units: μS , mS, k Ω , M Ω , PPM

Environmental

Operating temp.: -10 to 55°C (14 to 131°F), 50°C (122°F) max. with optional rear cover

Storage temp.: -15 to 80°C (5 to 176°F)

Relative humidity: 0 to 95%, non-condensing

Altitude: 4000 m max.

Pollution degree: 2

Electrical

Power requirements:

- 12 to 24 VDC or 12 to 24 VAC, unregulated, 50-60 Hz, 10 W max.

Temperature input:

- PT1000, 0 to 100°C (32 to 212°F), optically isolated

Relay outputs (2 sets):

- Mechanical SPDT contacts
- Max. voltage rating: 5 A @ 30 VDC, 5 A @ 125 VAC, or 3 A @ 250 VAC, (power factor = 1.0)
- Hysteresis: User adjustable

Current output:

- 4 to 20 mA, non-isolated, internally powered, fully adjustable and reversible
- Update rate: <2s
- Max loop impedance: 350 Ω with a 12 V instrument supply voltage, 950 Ω with a 24 V instrument supply voltage
- Accuracy $\pm 0.1\%$ of max range

Noise immunity: EN50082-2

Noise emissions: EN55011

Safety: EN61010-1

Agency Approvals

- CE, UL listed
- Manufactured under ISO 9001

Figure 1

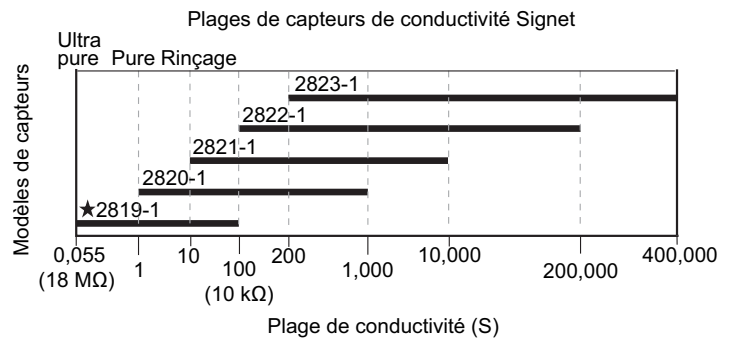

Dimensions:

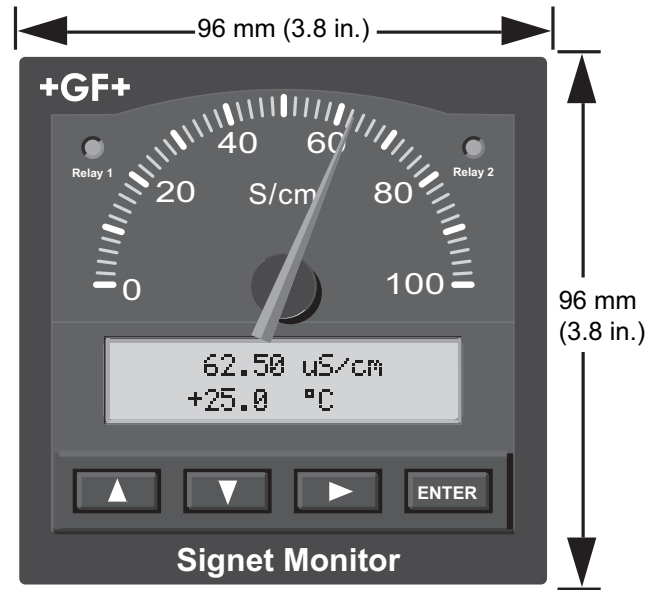

Front View

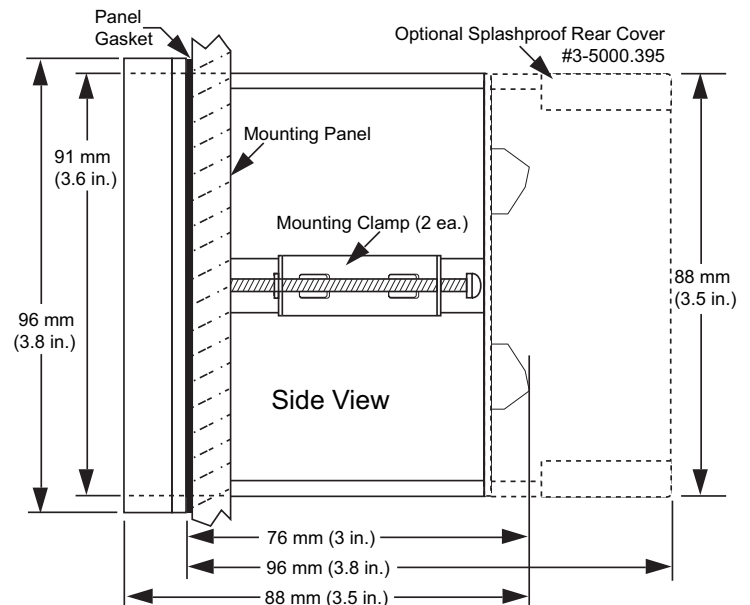

Dimensions:

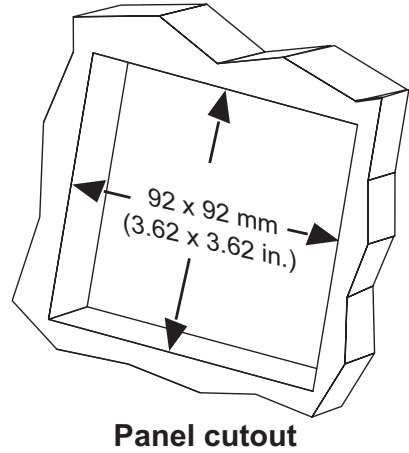
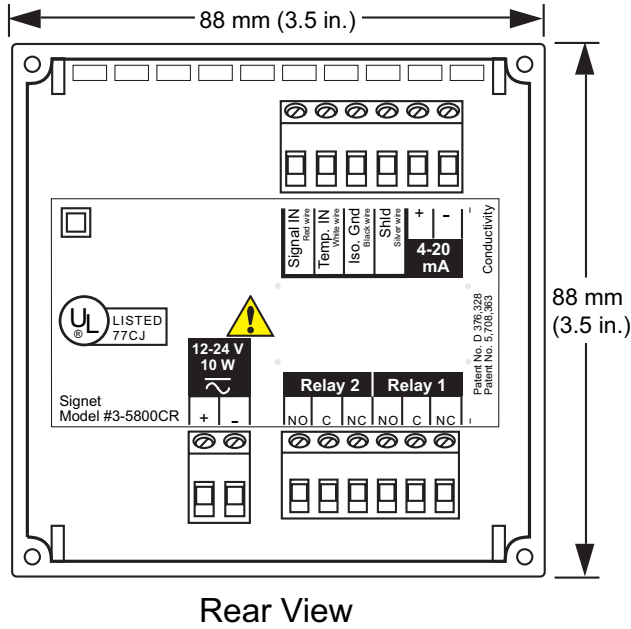

11. Quick Reference Menu Parameters

11.1 VIEW Menu Setup Parameters (sec. 6.1)

Menu Parameters	Display Description	Range	Factory Default
A. 0.0 uS/cm +25.0 °C	• Process conductivity • Process temperature	• 0.055 - 400,000 mS (10 k - 18 M) • Process temperature	n/a n/a
B. LOOP Output: 20.00 mA	Current loop output	3 - 21 mA	n/a
C. Min→Max: uS/cm 0.0000+100.000	Min → Max meter dial range	0.055 - 400,000 mS (10 k - 18 M★)	0.0000 - 100.000 mS/cm
D. Relay 1: Low 10.0000 uS/cm	• Relay 1 mode • Relay 1 setpoint	Low, High, or Pulse, 0.055 - 400,000 mS (10 k - 18 M)	Low 10.0000 mS/cm
E. Relay 2: High 90.0000 uS/cm	• Relay 2 mode • Relay 2 setpoint	Low, High, or Pulse, 0.055 - 400,000 mS (10 k - 18 M)	High 90.0000 mS/cm
F. Last CAL: 01-01-98	Last calibration date	00 - 00 - 00 - 39 - 39 - 99	01 - 01 - 98

★ Resistivity/conductivity measurements from 10 MΩ to 18 MΩ (0.055 μS to 0.1 μS) must be performed in solution temperatures from 20°C to 100°C.

11.2 CALIBRATE Menu Setup Parameters (sec. 6.2)

Menu Parameters	Display Description	Range	Factory Default
A. Cell: Standard 1 >	Sensor type: and cell constant	• Standard sensor cells: 0.01, 0.1, 1.0, 10.0, 20.0 • Custom sensor cells: 00.0000 - 999999.	• Standard sensor •Cell 1.0
B. Units: uS >	Process units	mS, mS, PPM, k, or M	mS
C. PPM Factor: 2.00 >	Total dissolved solids (PPM) factor	0.01 - 9.99	2.00
D. Min+Max: uS/cm 0.0000+100.000 >	Min → max meter dial range	0.055 - 400,000 mS or 10 k - 18 M	0.0000 - 100.000 mS
E. WET CAL: >	System Calibration Procedure	Wet Solution or resistor calibration	n/a
F. Relay 1: Low 10.0000 uS/cm >	• Relay 1 mode • Relay 1 setpoint	• Low or High • 00.0000 - 999999.	Low 10.0000 mS/cm
G. Relay 1 Hys: 1.0000 uS/cm >	Relay 1 hysteresis	• Low or High 00.0000 - 999999.	1.0000 mS/cm
H. Relay 1: Pulse 10.0000+90.0000 >	• Relay 1 mode • Relay 1 range	• Pulse • 00.0000 - 999999.	10.0000 - 90.0000 mS/cm
I. Relay 1 Rate: 120 Pulses/min >	Relay 1 pulse rate	000 - 300 pulses/minute	120 pulses/minute
J. Last CAL: 01-01-98 >	Last calibration date	00 - 00 - 00 - 39 - 39 - 99	01 - 01 - 98

PPM Factor shown only with PPM units selected above (step B)

Relay mode and set-point displays repeat for relay 2 setup

11.3 OPTIONS Menu Setup Parameters (sec. 6.4)

Menu Parameters	Display Description	Range	Factory Default
A. Contrast: 3 >	Display contrast	0 - 5	3
B. Display Decimal: XXXX.X >	Display decimal	*.**** _ ****.	****.*
C. Display Average: Low >	Display averaging	Off= 0 sec., Low= 4 sec., High= 8 sec.	Low= 4 sec.
D. Set 4 mA: 0.0000 uS/cm >	4 mA setpoint	00.0000 - 999999.	00.0000 mS/cm
E. Set 20 mA: 100.000 uS/cm >	20 mA setpoint	00.0000 - 999999.	100.000 mS/cm
F. 4 mA Adjust: 4.00 mA >	4 mA adjust	3.0 - 5.0 mA	4.00 mA
G. 20 mA Adjust: 20.00 mA >	20 mA adjust	19 - 21 mA	20.00 mA
H. Temperature: °C >	Temperature display	Celsius or Fahrenheit	C
I. Temperature Comp %: 2.00 >	Temperature comp. percentage	0.00 % - 9.99 %	2.00 %

12. Troubleshooting

Display	Problem	Solution
1. 0.0 μ S/cm ----- $^{\circ}$ C or ----- μ S/cm ----- $^{\circ}$ C or 0.0 M Ω •cm ----- $^{\circ}$ C or -----M Ω cm 25.0 $^{\circ}$ C	Temperature wiring shorted or temperature element in sensor bad	A) Verify sensor wiring (sec. 2) B) Verify instrument temperature input: <ul style="list-style-type: none"> Remove Black and White sensor wires from rear Temp. IN and Iso. Gnd terminals, then place a 1100 Ω resistor across terminals. Power instrument and verify approximately 26.0$^{\circ}$C (79$^{\circ}$F) on display. If instrument reads correctly, replace sensor. If error condition persists, instrument requires factory service.
2. 0.0 μ S/cm 25.0 $^{\circ}$ C or ----- M Ω •cm 25.0 $^{\circ}$ C	A) Sensor not connected or improperly connected B) Pipe empty or sensor not in solution C) Wrong scale selected D) Wrong range selected (cell constant too small) E) TC% set incorrectly for process temperature F) Sensor wiring open G) Water too cold for high-purity water measurement	A) Verify sensor wiring (sec. 2) B) Fill pipe or place sensor in process solution. C) Choose μ S or M Ω scale instead of mS or k Ω scale (sec. 6.2B) D) Choose a sensor with cell constant adequate for your process solution (sec. 10, Figure 1) E) Set TC% to zero (sec. 6.41) and check reading. If reading is ok, calculate proper TC% for your process solution (sec. 8), then re-enter correct value (sec. 6.41). F) Replace sensor G) See specifications section 10 for recommended high-purity range and temperature requirements.
3. -----uS/cm 25.0 $^{\circ}$ C or 0.0 M Ω •cm 25.0 $^{\circ}$ C	A) Sensor shorted or improperly connected B) Wrong scale selected C) Wrong range selected (cell constant too large) D) TC% set incorrectly for process temperature	A) Verify sensor wiring including cable splice (sec. 2); cable shield must continue through splice. B) Choose mS or k Ω scale instead of μ S or M Ω scale (sec. 6.2B) C) Choose a sensor with cell constant adequate for your process solution, see section 10, Figure 1. D) Set TC% to zero (sec. 6.41) and check reading. If reading is ok, calculate proper TC% for your process solution (sec. 8), then re-enter correct value (sec. 6.41).
4. Too Much Error Check Sensor	Temperature input out of tolerance during WET CAL Procedure (sec. 6.3)	Exit WET CAL Procedure by pressing UP and DOWN arrow keys simultaneously, then refer to solution steps 1B above to verify sensor temperature input.
5. Reset To Factory Calibration	Zero entered as solution conductance or resistance during WET CAL step 2	Measured conductivity, Resistivity, PPM, or resistivity entered as zero to quickly recall factory defaults.
6. SETUP READ ERROR Press any Key	Power fault occurred while saving setup menu entry	Press any key to reload factory defaults then reprogram conductivity system setup parameters.

13. Maintenance

Clean the instrument case and front panel with a soft cloth and a mild liquid soap solution.



#1119 Woorim-Lionsvalley II, 680 Gasan-Dong, Guemcheon-Gu, Seoul
http : www.fnsplus.com Tel : 82-2-2027-2380 Fax : 82-2-832-1017

+GF+

George Fischer Signet, Inc. 3401 Aerojet Avenue, El Monte, CA 91731-2882 U.S.A. • Tel. (626) 571-2770 • Fax (626) 573-2057
For Worldwide Sales and Service, visit our website: www.gfsignet.com • Or call (in the U.S.): (800) 854-4090

