



Infocharger(ICC & ICH)

DC POWER SUPPLY/BATTERY CHARGER



Important Notices!

Thank you for choosing this charger system. This product can be used for both battery charger and DC power supply applications.



For the staff and equipment safety it is necessary for the users to fully read and save this manual before working on this equipment.

Description of the Symbols



IMPORTANT NOTICE! Please follow the instructions.



LIFE RISK! Please follow the instructions



DANGER! Please follow the instructions otherwise the unit can be damaged or user can be hurt

Contents

1	Safety	3
2	System Description	4
3	Installation	6
3rd1	Handling	6
3rd2	Storage.....	6
3rd3	Positioning.....	6
3rd4	Connections	7
3rd4.1	Ground (Earth) Connection	9
3rd4.2	Input connection.....	9
3rd4.3	Battery connection.....	9
3rd4.4	Output connection	9
4	Switch ON and Switch OFF procedures	10
4th1	System Switch ON	10
4th2	System Switch OFF	10
5	Operating Instructions	11
5th1	Unit Operation	11
5th1.1	Operation modes	11
5th2	Displays.....	12
5th2.1.1	LCD Display.....	12
5th2.1.2	MENU STRUCTURE.....	13
5th2.1.3	Buttons	15
	There are mainly four buttons in the front panel. The functionalities of the buttons are given below.	15
6	Operating Procedures for Parallel Systems (Optional)	17
7	Optional Modules	19
8	Maintenance.....	20
9	Trouble Shouting	21
10	Technical Specifications	22
11	Block Diagrams.....	25

1 Safety



For the staff and equipment safety, it is necessary for the users to fully read and understand this manual for DC Power Supply/Battery Charger before installation and operation.



Avoid the sudden temperature changes, which can cause condensation inside the battery charger. Otherwise, wait at least for two hours before switching on.

This product should be installed according to the instructions defined at chapter 3.3 'Positioning'.

Do not close ventilation holes or other openings.

Keep away the liquid and solid object entry inside the unit.

Installation and commissioning have to be done by authorized technical service.

Earth (Ground) connection should be done.

Do not plug in/off the communication interface cables during bad weather conditions with lightning.

To avoid the risk of fire, all the connections have to be done according to the suggested cable cross-sections. The cables should be isolated type and properly installed.

Do not connect exceeding load than charger's nominal power to the output.

Maintenance and service of the equipment should be done by authorized technical service staff.

In case of emergency (damage of the cabinet, front panel or connections etc.) switch off the battery charger, disconnect the input supply and inform the authorized technical service staff.

The unit should be packed properly if it is needed to be moved.

2 System Description

DC Power Supply Operation Mode

If the equipment is being ordered as DC Power Supply, then the unit supplies a limited voltage and current value that is adjusted from the front panel to the connected DC load. The output voltage and current limits can be easily adjusted separately from the SETTINGS menu on the LCD panel.

Battery Charger Operation Mode

The equipment that is ordered as battery charger has the following specifications. This operation mode has 4 grades charging level depending on the battery type. These are initial charge, float charge, boost charge and temperature or auto controlled charging types. The charge voltages per cell are ; for initial charge: 2.04V, for float charge: 2.23V, for boost charge: 2.375V, for temperature controlled charge ; 2.17V at 0°C / 2.29V at 50°C. These values are factory set, but only temperature controlled charging values can be set from front panel according to the battery type.

LVD (Low Voltage Disconnect) is available as an option. This function protects the batteries from deep discharge by disconnecting them from output during battery mode when the mains is absent.

Additionally, the optional dry contact alarm card provides automation functionality to the device.

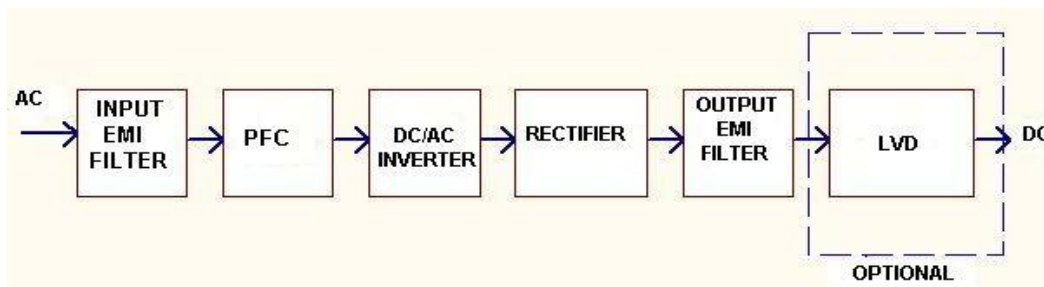

ICC SYSTEM BLOCK DIAGRAM

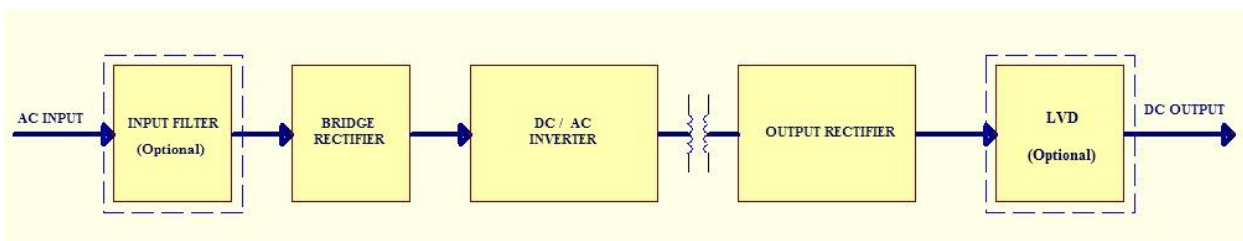

ICH SYSTEM BLOCK DIAGRAM

Input EMI filters (Optional)

These filters prevent electromagnetic interference between Infocharger, mains and loads. (EMI – electromagnetic interference)

Your battery charger and loads are protected against high voltage.

Bridge Rectifier

This unit converts the AC voltage from mains to DC voltage.*

*Available with ICH system.

DC / AC Inverter

The inverter helps to obtain a very constant AC voltage level at the output by using DC voltage at the boost's rectifier output.

Rectifier

This unit draws on the mains the power required to supply the inverter and to recharge the batteries. The alternating input voltage is rectified and distributed to the batteries.

Low Voltage Protection (Optional)

This type of protection is used as optional to prevent the deep discharge of the loads in the absence of the power at mains, and this voltage level can be adjustable at the front panel.

Your Battery Charger' features and benefits:

Feature	Benefit
SMPS technology Transformerless design	Compact design, small dimensions and low weight
Microprocessor controller	<ul style="list-style-type: none">▶ To use all the sources in optimum level.▶ To observe carefully the failure conditions
PFC technology (only for ICC)	High input power factor <ul style="list-style-type: none">▶ To consume low reactive power▶ Not to load the installation extra (cables, transformers, generators etc.) Clean power for the mains.
Wide input voltage tolerance	This helps to reduce battery usage and guarantees battery to be fully charged and extends the battery life time. On-line operation even the mains is between 90 – 265 V for ICC and 176 – 265 V for ICH.
On-line double conversion topology	The output voltage of the Infocharger is DC. Infocharger input total harmonic distortion is very low. This is very important for both the systems and batteries which are supplied by Infocharger.
Temperature Management	<ul style="list-style-type: none">▶ To calculate overloading time in a reliable way.▶ To protect against over temperature.
Modular System Architecture	<ul style="list-style-type: none">▶ Parallel connection is available up to 7 units if you use InfoCharger ICH model as battery charger.
Dry Contact Information	<ul style="list-style-type: none">▶ Provides monitoring of your InfoCharger from your automation by relays and microprocessor.
Effective output voltage regulation: (output voltage is not affected by changes on the mains input and load level.)	
High efficiency (low power consumption)	

3 Installation



Check if the Infocharger has been subjected to any damage before unpacking it. If you notice any damage, please contact to transport firm. Check if all the additional parts have been supplied with the battery charger.

Please make sure that the packing contains the following

Infocharger

User Manual

Test Report



Before the installation, please check if your Infocharger is customized following your special requirements (if any).



The standard unit's output voltage can be adjustable between 0, 30, 60, 150, 300VDC.

3rd1 Handling



If needed to move the battery charger, it is obligatory to pack the unit. It is suggested to keep the original packing.

3rd2 Storage

Please store the battery charger in an environment where the temperature is between $-15\text{ }^{\circ}\text{C}$ and $+70\text{ }^{\circ}\text{C}$ no receipt of direct sunlight, far from the heating, in a dry place. Environmental humidity must be between %20 and %95 (non-condensing).

3rd3 Positioning

Infocharger and battery cabinet(if any) have to be positioned in an environment;

No direct sun access,

Must be dry,

Far from the heating equipments

No excessive dust

Well-ventilated

In order to maintain adequate ventilation of Infocharger and battery cabinets (if any), ensure the air vents are not blocked and leave at least 20 cm space at the rear side of the unit for ventilation.

3rd4 Connections



Connections must be done by authorized technical service staff. Life risk for user!



Temperature changes such as from cold to hot environment can cause condensation. It is dangerous to operate the Infocharger. Please wait at least two hours before making the connections.

Connection terminals are on the front side of ICC models and on rear side of ICH models. Please take out the cover of the rear side to make the connections.

Standard Infocharger connections are shown below.

ICC Models;

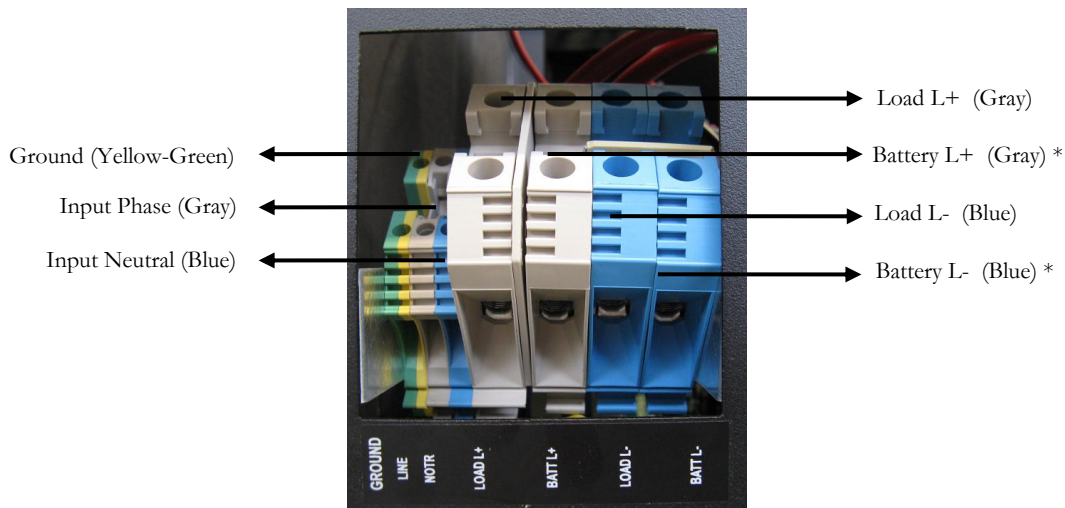

1 PHASE INPUT

* Battery connection terminal is available with LVD option.

ICH Models;

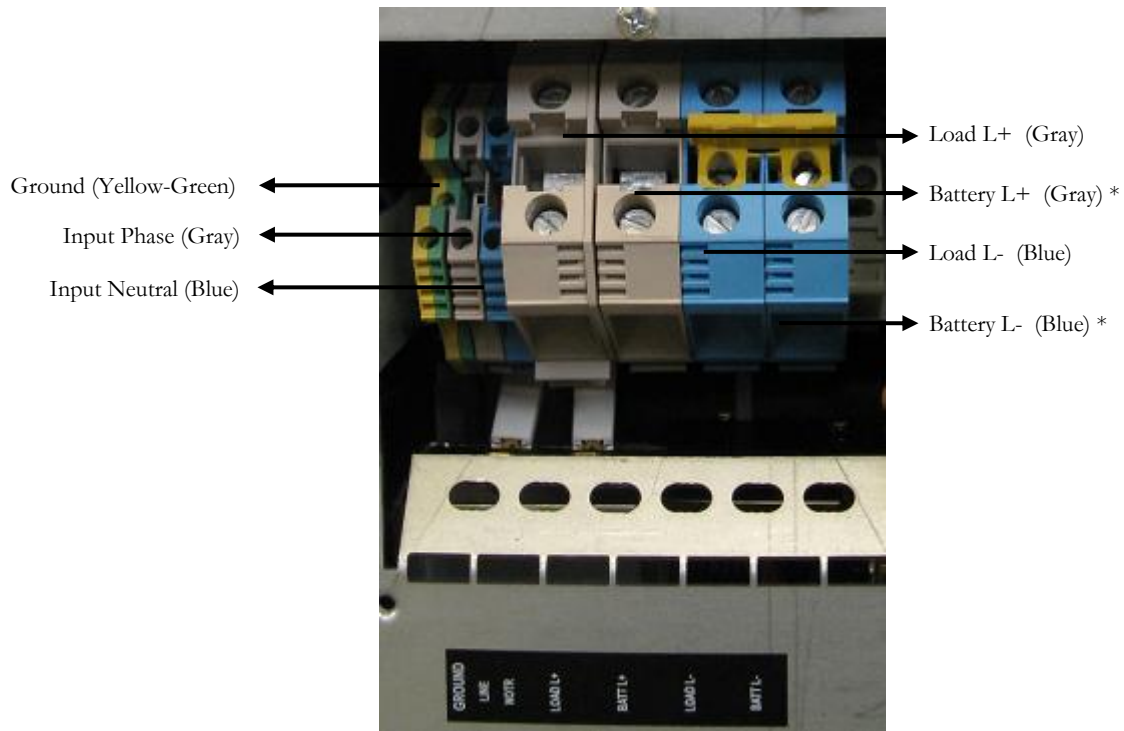

1 PHASE INPUT

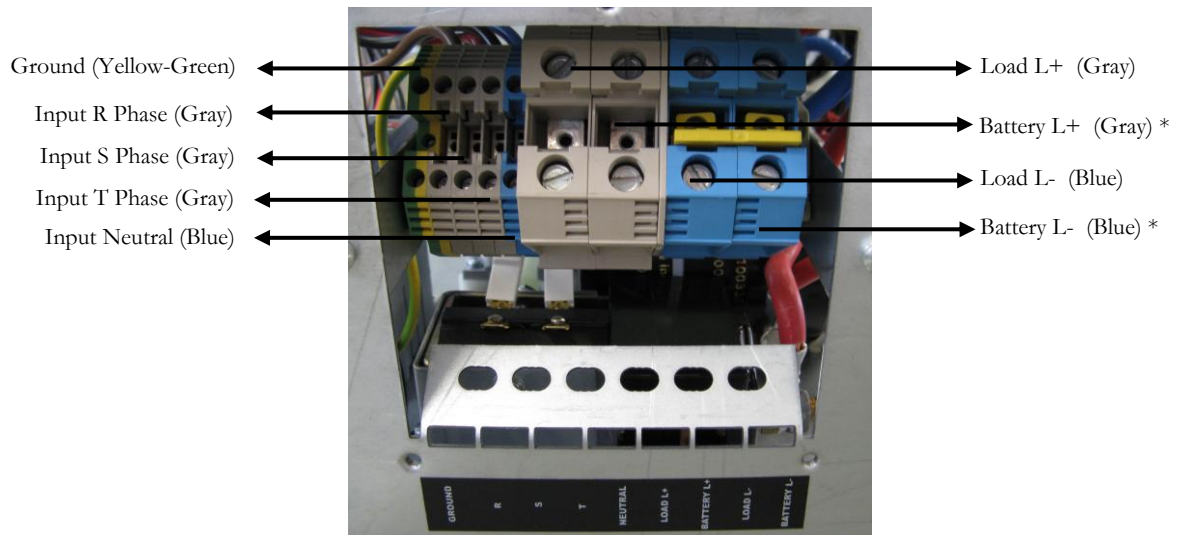

3 PHASE INPUT

* Battery connection terminal is available with LVD option.

Please follow the instructions as explained below.

3rd4.1 Ground (Earth) Connection



Inforcharger ground (earth) connections have to be done.

The input ground terminals of the Inforcharger should be connected to a reliable (low resisted) ground

The grounding connection of the loads can be done over the output grounding contactor.

The grounding connection of the external battery cabinet(if any) should be done over the same battery grounding contactor.

The connection between the grounding unit of the Inforcharger and the ground can be made according to the minimum cross-sectioned cables which are given in the technical specifications table below.

3rd4.2 Input connection

The connections between the distribution frame and Inforcharger for phase, neutral and ground are explained as below;

FOR ICC: The Phase, Neutral and ground must be connected to their contactors on the front panel with a 2.5 mm² cross-section multi-vein cable.

FOR ICH: For single phase models, the Phase, Neutral and ground must be connected to their contactors on the back panel with a 10 mm² cross-section multi-vein cable.

For three phase models, the R, S, T, Neutral and ground must be connected to their contactors on the back panel with a 4 mm² cross-section multi-vein cable.



Changes on distribution panel have to be done by authorized persons only.

3rd4.3 Battery connection

The batteries must be connected to the L+ (positive) and L- (negative) points properly (If LVD is used with device, the batteries must be connected to B+ and B- terminals). The DC power supply type Inforcharger does not have this connection. The batteries have to be connected with an external circuit breaker.

3rd4.4 Output connection

The terminal on the equipment can be used for the + and – output points. The cables to these terminals are connected to the fuses and the protection is over the (L+) point.

4 Switch ON and Switch OFF procedures

4th1 System Switch *ON*

After making all the connections mentioned in the previous chapter,

- First switch on input fuse and check output voltage
- Then switch on output fuse and battery fuse (if any)

If mains voltage is within the limits, the unit switches on.

InfoCharger makes self-test for few seconds to check if everything is normal, and then starts to charge the batteries or supply the load.

4th2 System Switch *OFF*

To stop the load to be supplied or the batteries to be charged, please switch off the all automatic fuses in the front panel.

5 Operating Instructions

5th1 Unit Operation

Infocharger; is designed for the usage as a Battery Charger or DC Power Supply. Output current, voltage and the float charge limits are adjustable on the front control panel easily.

5th1.1 Operation modes

- **Battery Charger**

The device charges batteries by converting AC voltage to DC voltage. Current limit, output voltage and charging temperature can be adjustable from front panel.

The battery current and voltage characteristics are shown in the figure below

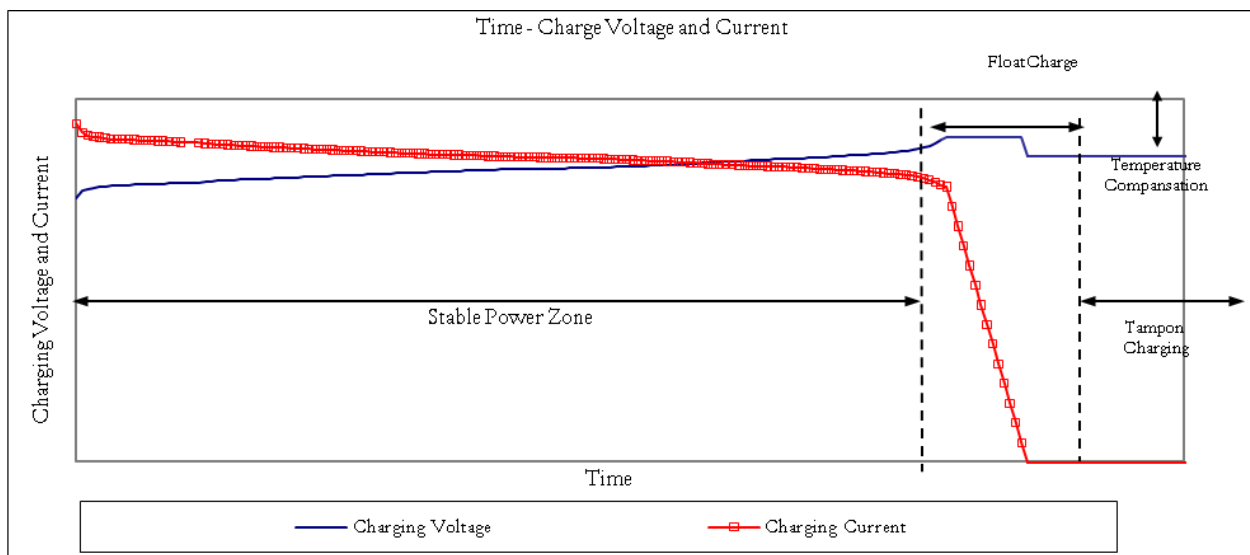

Battery current is controlled in a way to keep stable the power transferred to batteries in direct charge zone. If the voltage passes a certain value, float charging starts. It is applied fixed voltage 2,23V per battery. Float charging takes 30 minutes. Then it passes to tampon charging. During the tampon charging, it is applied fixed voltage 2,25V per battery in 25 °C environment temperature. Auto charge voltage is adjustable according to the environment temperature.

- **DC Power Supply**

The device supplies the DC load by converting AC voltage to DC voltage. Current limit and output voltage can be adjustable from front panel.

5th2 Displays

The front panel of the Infocharger is shown below:



Infocharger control panel is composed of;
 LCD Display (Liquid Crystal Display),
 LEDs
 Buttons

5th2.1.1 LCD Display

There are mainly four display sections on the control panel as follows

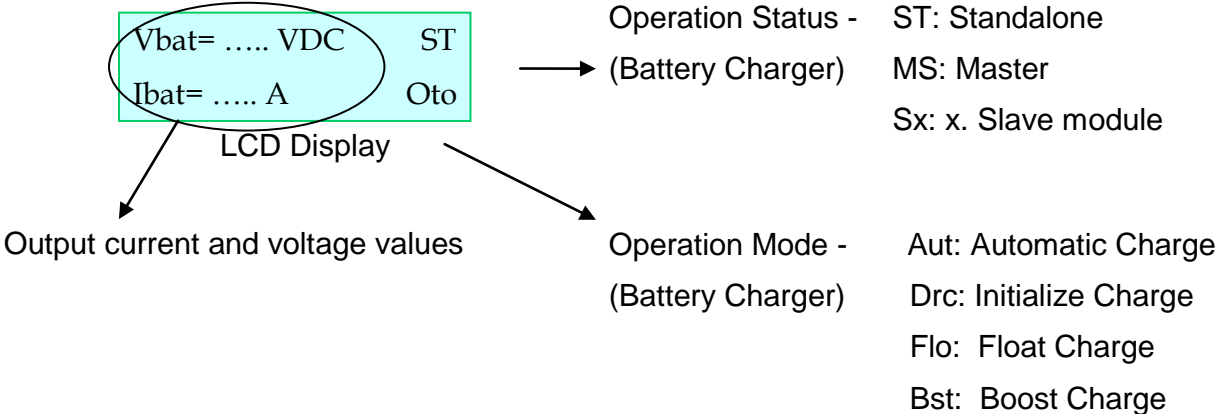

On the “Operation status” section of the display, parallel operating mode is monitored.
 ST: If InfoCharger operates in single mode (standalone), this message is monitored.
 MS: If InfoCharger operates in parallel mode and is assigned as master, this message is monitored.

👉 Operating modes can be adjusted on only MS (master) unit.

Sx: If InfoCharger operates in parallel mode and is assigned as slave, this message is monitored.



Slave units operate in “Float” mode and operation mode can not be adjusted when parallel communication is cut.

On the “Operation mode” section of the display, the actual operating mode can be monitored. On the left part of this display section the following messages can be observed:

DRC : Initial Charging
FLO : Float Charging
BST : Boost Charging
AUT : Automatic Charging

5th2.1.2 MENU STRUCTURE

1 - ANALOG VALUES

Vbatt : Battery voltage (VDC)
Ibatt : Battery current (Idc)
Vinput : Input voltage (VAC)
Tred : Internal temperature of the charger (°C)
Tenv : Environmental (ambient) temperature (°C)

2 - ADJUSTMENTS

BATTERY CHARGER

Battery Type : Maintenance Free Lead Acid, Ni-Cd
Battery Capacity : Between 0 – 1000 Ah adjustable
Charging Current : Between 0 – 100% adjustable
Low Voltage Protection : Active or Passive
Temperature Charging : Active or Passive
0°C voltage value : Depends on type (Temperature Charging voltage value 0°C)
50°C voltage value : Depends on type (Temperature Charging voltage value 50°C)
Max Charging Duration : 0 – 120 minutes adjustable for ICH, 0-10 hours adjustable for ICC
Low Voltage Limit : LVD low limit (Adjustable between 19-22, 38-44, 86-92, 172-184 VDC)
Charging Limit : Direct, Float, Boost, Automatic charging limits

DC POWER SUPPLY

Vout: The output voltage is adjustable between 0, 30, 60, 150, 300VDC.

Iout: It is adjustable between 0-255.

3 - ALARMS

Vinput : In case of the voltage at mains is out of limit value

Vbatt : In case of the battery current is out of limit value

Vload : In case of the load voltage is out of limit value

Tcharger : In case of the measured value over the ventilator is higher than limit value.

Tamb : In case of the operating temperature is higher than the limit value

CURRENT LIMIT: Shows the output current value is equal to (nominal) current or greater than the (nominal) current

LVD : When the charger is at charger mode, it shows that the battery voltage is below the adjusted value.

EEPROM : When the memory log is not functioning.

INVERTER : When a fault occurs on inverter side.

4 - UNIT INFORMATION

Type : One of the following device type;

ICC: 24V-60A, 48V-30A, 110V-15A

ICH: 24V-200A, 48V-100A, 110V-50A, 220V-25A

Address : Binary system is used

Between 001 – 110 Sx Slave (up to 6 units)

111 Master Unit

Ver : Microprocessor software version.

Seri no : Serial number

5 - MODULE INFORMATION

Only monitored during parallel mode. Analog values and present alarms of the other units can be monitored.

6 - SYSTEM SWITCH ON/ SWITCH OFF

It is used of turning ON or OFF device.

7 - LANGUAGE SELECTION

Language: English, Turkish

5th2.1.3 Buttons

There are mainly four buttons in the front panel. The functionalities of the buttons are given below.



button: Scroll down to next line



button: Scroll up to previous line



button: Exit from the active menu.



button: Enter to active menu.

MENU STRUCTURE OF INFOCHARGER MENU SCREEN

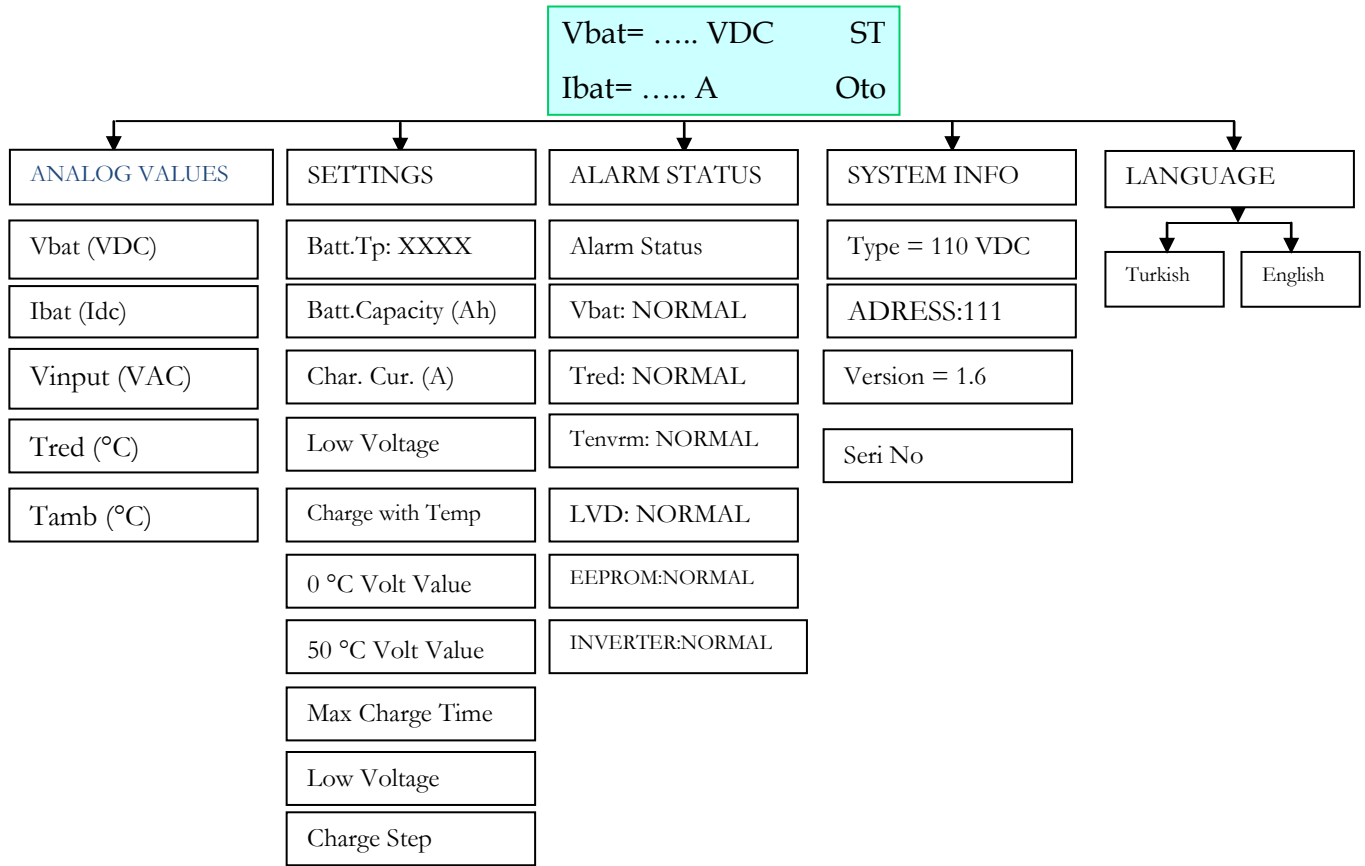

6 Operating Procedures for Parallel Systems (Optional)

InfoCharger can be purchased with parallel option for supplying the very critical load to increase the reliability. Maximum 7 identical power and specification InfoCharger can be connected in parallel.

Procedure for Commissioning and Start Up (First Installation)

- 1) The AC inputs of all units in the parallel system are connected to the same mains, and all the DC outputs are connected to each other. The critical load and batteries are connected to the common output of the parallel system.

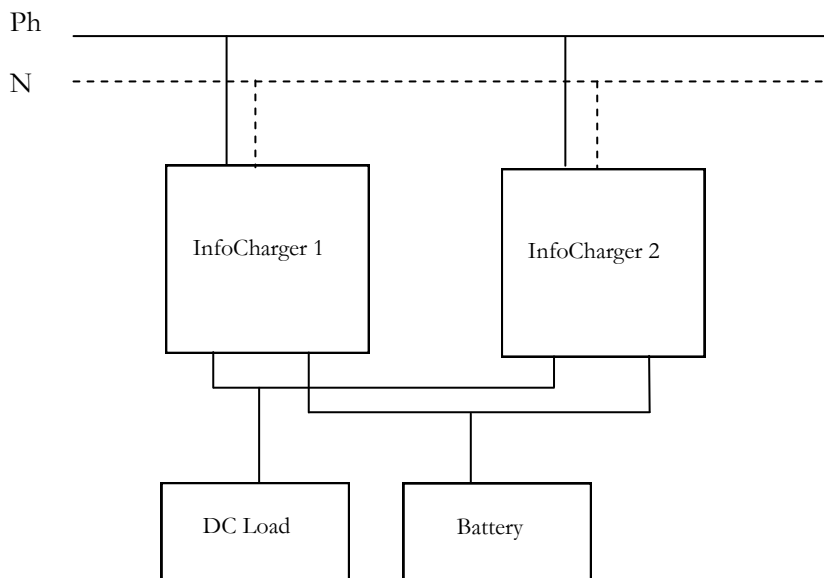

(OUTPUT CONNECTION OF PARALLEL CHARGER SYSTEMS)

- 2) There are also some signal cable connections between the charger units necessary for parallel operation. The Communication of parallel systems is made according to communication protocol. Before starting up the DC units, make the connection of communication cables between units as per below diagram:

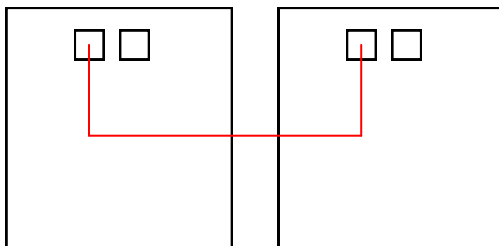

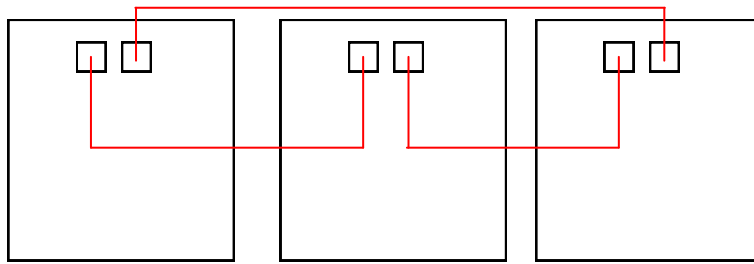

(COMMUNICATION CABLE CONNECTION BETWEEN PARALLEL CHARGERS)

CAUTION: Do not remove the communication cables between the Chargers during parallel operation.

In case this communication cable is removed or damaged during parallel operation and the communication is lost then the slave DC unit which cannot communicate with the master DC unit shall still supply the load at float mode. It shall not receive any further commands from Master unit.

- 3) All switches should be in “OFF” (“0”) position.
- 4) Switch on DC units.

Note: DC units are factory parallel configured.

- 5) After all DC units starts operating in parallel, on the LCD panel, MS (master) and Sx (x defines no of slave unit) messages should be observed.

7 Optional Modules

There are mainly two optional modules for the Infocharger

These are;

- 1- LVD Module: This module prevents the loads and batteries to be deeply discharged. A relay is used for the separation of the batteries from the load. This relay is on B+ side. The voltage level of this separation process can be chosen on the control panel. This voltage level can not be less than 1,65V which is the minimum voltage level per cell.
- 2- Relay Module: This module is designed for the automation processes and has 9 relay output

These are as follows;

- a. TOTAL ALARM: Total Alarm
- b. CUR LIM: Operating within the current limit
- c. FAN FAILURE: FAN FAILUE (Available only on ICC)
- d. TEMP HIGH :Ventilator temperature is out of limit
- e. VLOAD OUL: Load voltage is out of limit
- f. VBAT OUL: Battery voltage is out of limit
- g. VIN OUL : Mains voltage is out of limit
- h. +DC LEAKAGE: Leakage current to the earth at output + string
- i. -DC LEAKAGE: Leakage current to the earth at output - string

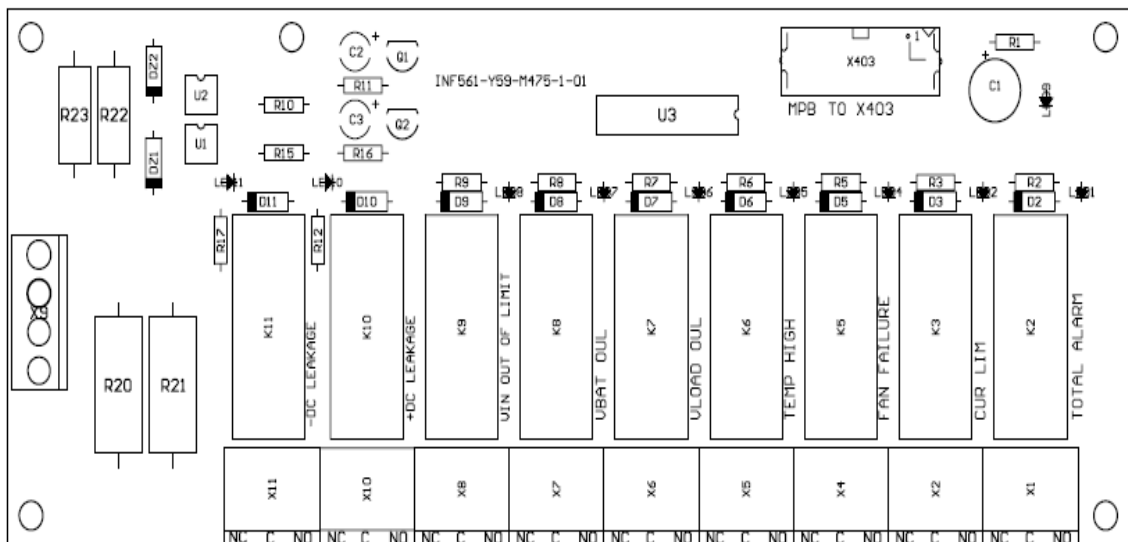

In the event of error; “Total alarm”, “Vin out of limit”, “Vbat OUL”, “Vload OUL” relays become unenergized, and other relays become active.

8 Maintenance

The Infocharger unit does not need maintenance.

If you want to make cleaning on the unit, than you should perform the following:

Disconnect the loads

Bring all the fuses on the unit to “0” position. (Wait for capacities to discharge for 10 minutes)

Clean the unit with a slightly moistened cloth.



Do not drop any liquid and solid foreign substance inside the unit.



Do not use a cleaning powder or any other material that may damage the plastic parts.

9 Trouble Shooting

In this section, procedures that should be followed are explained during an abnormal condition of the unit. Before you inform the technical service, read and apply carefully things explained in detail in this section.

If the fault led on front panel is on; then go to the main menu on front panel and check what the fault is.

If the LEDs on front panel are all off please check input fuses.

If you can read the battery and load voltage on front panel but can not measure the same voltage at battery and load then check the battery and load fuses.

If there is an over temperature failure, please check the ventilator if it is running.

If there is a problem with the batteries (boiling or over heating), please check the battery charge current and voltage on the front panel.

If you still have problems, please call technical service.

Please note the model and the serial number of the unit which are present on the rear panel label. Describe the problem with full information.

10 Technical Specifications

ICC MODELS							
Dimensions							
Height	28 cm	Width	25 cm	Depth	42 cm	Weight	11,6 kg
Environmental Conditions							
Temperature	Operating	0 ... +40 [°C]		Relative Humidity	Operating	%5 ... %90	
	Storage	-15 ... +70 [°C]			Storage	%0 ... %95	
Electrical Specifications							
Connection cable's section area				BATTERY		INPUT	
24V 60A				10mm ²		2,5mm ²	
48V 30A				6mm ²		2,5mm ²	
110V 15A				4mm ²		2,5mm ²	
Input							
Nominal Voltage				220V			
Nominal Frequency				50Hz			
Input voltage range at mains running				90 – 265 V			
Input frequency range at mains running				50 Hz / 60 Hz ±10%			
Power factor(at nominal input voltage)				>0,99 @ full load			
Current Total Harmonic Distortion (THD)[%]				<3%			
Efficiency				>90%			
Output							
Output voltage				24VDC	48VDC	110VDC	
Initial charge				24,5V	49V	112V	
Float charge				26,75V	53,5V	122,6V	
Fast charge				28,5V	57V	130,6V	
DC Supply				0-30V	0-60V	0-140V	
Short circuit current				110%	110%	110%	
Output current				60A	30A	15A	
Output Voltage fluctuations				<300mV	<600mV	<1V	
Dynamic response				2%<	2%<	2%<	
Output protection				Electronically short circuit protection / over current protection / reverse voltage protection			
Standards							
Protection Class				IP 20			
EMC				EN 50091-2			
Performance				EN 62040-3, EN 50091-3			
Safety				EN 50091-1			
Product Certification				CE, TSEK			

ICH MODELS								
Dimensions								
Height	56 cm	Width	26,5 cm	Depth	55.6 cm	Weight	35 kg	
Environmental Specifications								
Temperature	Operating	0 ... +50 [°C]		Relative Humidity	Operating	%5 ... %90		
	Storage	-15 ... +70 [°C]			Storage	%0 ... %95		
Electrical Specifications								
Connection Cable Cross Section				OUTPUT		INPUT	1 PH	3 PH
24V 200A				2X25mm ²			10mm ²	4mm ²
48V 100A				25mm ²			10mm ²	4mm ²
110V 50A				10 mm ²			10mm ²	4mm ²
220V 25A				4mm ²			10mm ²	4mm ²
INPUT								
Nominal Voltage				220V Ph-N or 380 Ph-Ph				
Nominal Frequency				50Hz				
Input voltage range at mains running				176 – 265 V				
Input frequency range at mains running				50 Hz / 60 Hz ±10%				
Power factor(at nominal input voltage)				>0,8 @ full load				
Efficiency				>90%				
OUTPUT								
Output voltage		24VDC	48VDC	110VDC	220VDC			
Initial charge		24,5V	49V	110V	220V			
Float charge		26,8V	53,5V	120V	240V			
Boost charge		28,5V	57V	128V	254V			
Dc Supply		0-30V	0-60V	0-140V	0-260V			
Short circuit current		104%	104%	104%	104%			
Output current		200A	100A	50A	25A			
Output Voltage fluctuations		<100mV	<200mV	<500mV	<1V			
Dynamic response		2%<	2%<	2%<	2%<			
Output protection				Electronically short circuit protection / over current protection / reverse voltage protection				
Standards								
Protection Class				IP 20				
EMC				EN 50091-2				
Performance				EN 62040-3, EN 50091-3				
Safety				EN 50091-1				
Product Certification				CE, TSEK				

Cable cross-section area (mm ²)	Current value absorbed by the load (Amp.)
1,5	18
4	34
6	44
10	61
16	82
25	108
35	135
50	168
70	207
95	250
120	292
150	335
185	382
240	453
300	504

THESE UNITS ARE GIVEN FOR THE MULTI-VEINS CABLES. THE CABLE SIZE SHOULD BE INCREASED PROPORTIONALLY REGARDING TO THE DISTANCE.

11 Block Diagrams

ICC BLOCK DIAGRAM

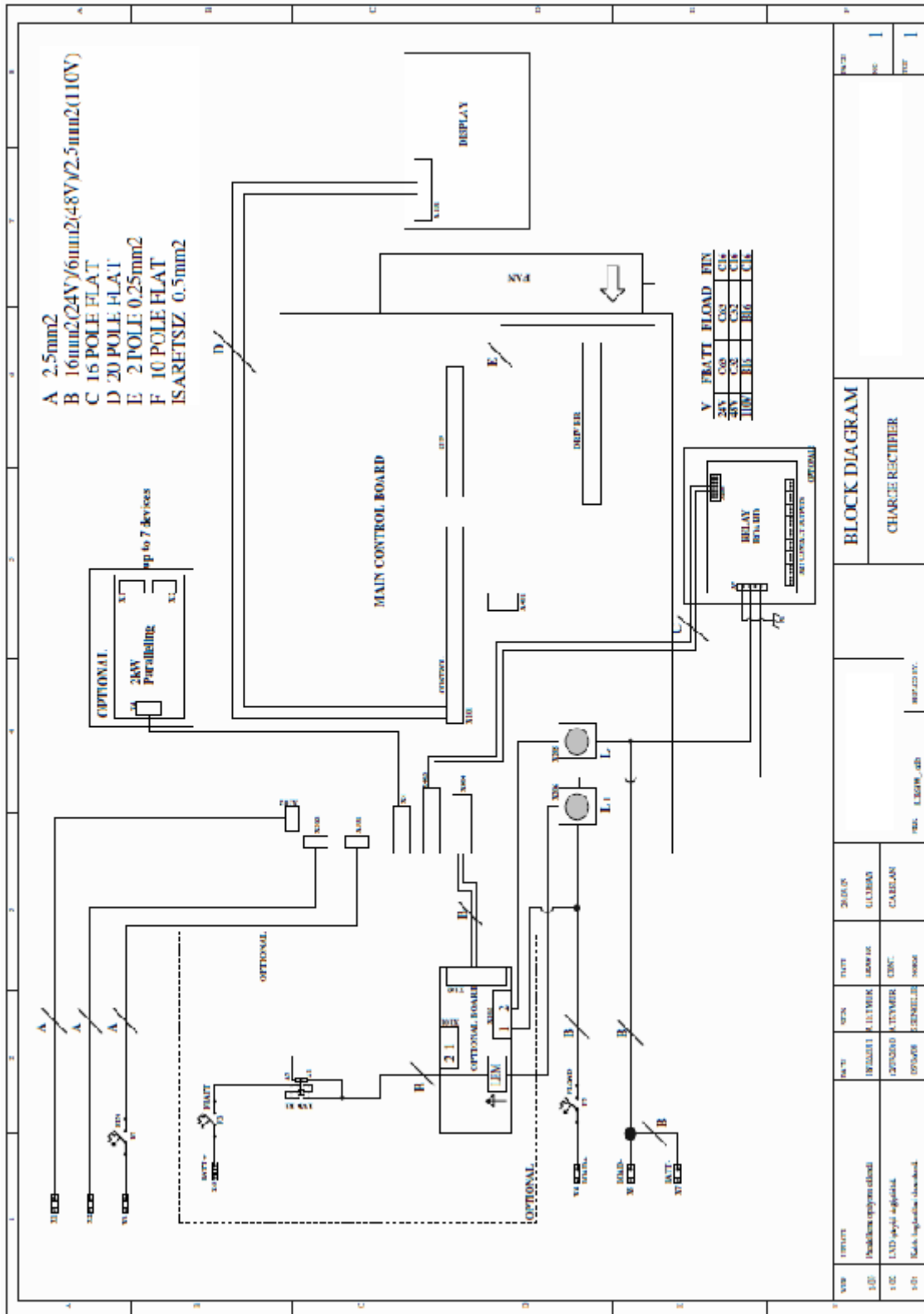

ICH BLOCK DIAGRAMS

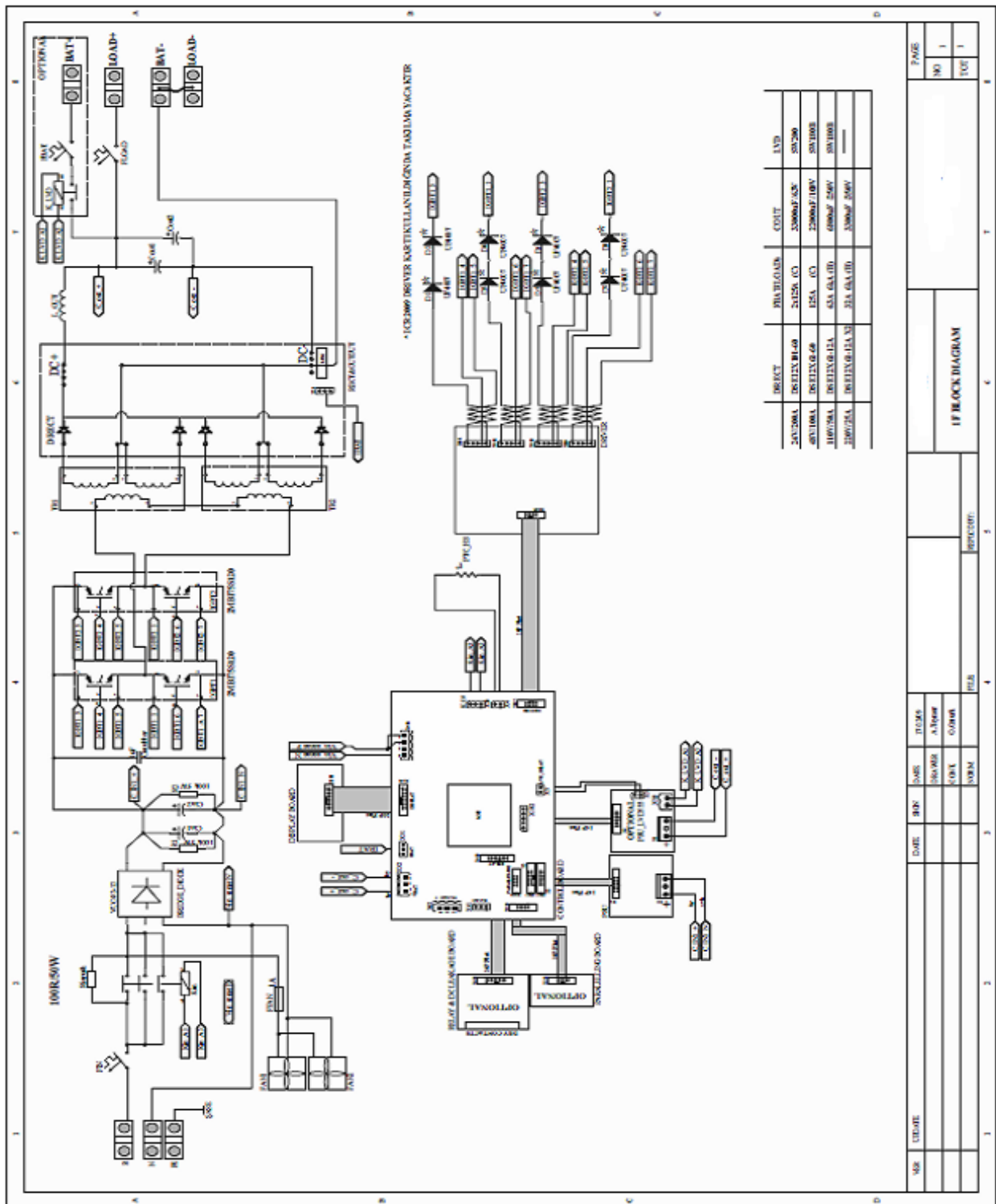

1-PHASE BLOCK DIAGRAM

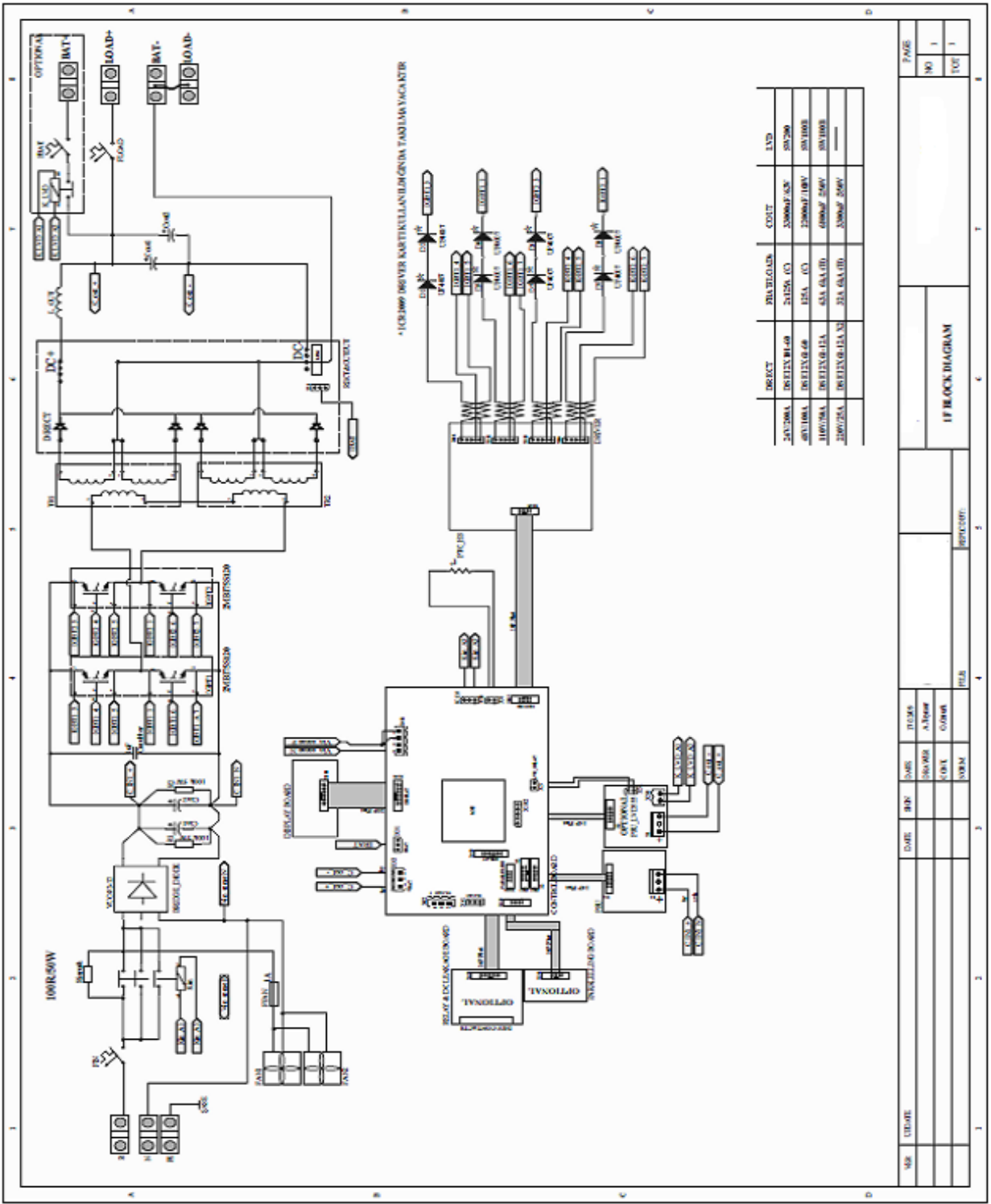

3-PHASE BLOCK DIAGRAM