

# **ADZS-BF707-BLIP2 Board Evaluation System Manual**

Revision 1.0, April 2015

Part Number  
82-100126-01

Analog Devices, Inc.  
One Technology Way  
Norwood, Mass. 02062-9106



## Copyright Information

©2015 Analog Devices, Inc., ALL RIGHTS RESERVED. This document may not be reproduced in any form without prior, express written consent from Analog Devices, Inc.

Printed in the USA.

## Disclaimer

Analog Devices, Inc. reserves the right to change this product without prior notice. Information furnished by Analog Devices is believed to be accurate and reliable. However, no responsibility is assumed by Analog Devices for its use; nor for any infringement of patents or other rights of third parties which may result from its use. No license is granted by implication or otherwise under the patent rights of Analog Devices, Inc.

## Trademark and Service Mark Notice

The Analog Devices logo, Blackfin, CrossCore, and EngineerZone are registered trademarks of Analog Devices, Inc.

Blackfin+ is a trademark of Analog Devices, Inc.

All other brand and product names are trademarks or service marks of their respective owners.

## Regulatory Compliance

The ADZS-BF707-BLIP2 board is designed to be used solely in a laboratory environment. The board is not intended for use as a consumer end product or as a portion of a consumer end product. The board is an open system design which does not include a shielded enclosure and therefore may cause interference to other electrical devices in close proximity. This board should not be used in or near any medical equipment or RF devices.

The ADZS-BF707-BLIP2 board is in the process of being certified to comply with the essential requirements of the European EMC directive 2004/108/EC and therefore carries the “CE” mark.



The BLIP2 board evaluation system contains ESD (electrostatic discharge) sensitive devices. Electrostatic charges readily accumulate on the human body and equipment and can discharge without detection. Permanent damage may occur on devices subjected to high-energy discharges. Proper ESD precautions are recommended to avoid performance degradation or loss of functionality. Store unused BLIP2 boards in the protective shipping package.





# CONTENTS

## PREFACE

Product Overview .....	x
Purpose of This Manual .....	xii
Intended Audience .....	xii
Manual Contents .....	xiii
What's New in This Manual .....	xiii
Technical Support .....	xiv
Supported Processors .....	xiv
Supported Tools .....	xv
Product Information .....	xv
Analog Devices Web Site .....	xv
EngineerZone .....	xvi
Notation Conventions .....	xvi

# Contents

## USING ADZS-BF707-BLIP2 BOARD

Package Contents .....	1-2
Default Configuration .....	1-2
BLIP2 Board Installation .....	1-3
BLIP2 Board Session Startup .....	1-4
Evaluation License .....	1-6
Mobile DDR Memory .....	1-7
SPI Flash .....	1-8
UART1 Interface .....	1-8
USB Interface .....	1-8
SD Interface .....	1-9
Debug Interface .....	1-9
Power-On-Self Test .....	1-9
RF Wireless Interface .....	1-9
Power Architecture .....	1-10
Example Programs .....	1-10
Reference Design Information .....	1-11

## ADZS-BF707-BLIP2 BOARD HARDWARE REFERENCE

System Architecture .....	2-2
Push Buttons .....	2-4
GPIO Push Buttons (SW1 and SW2) .....	2-5
Reset Push Button (SW3) .....	2-5
WAKE IO Push Button (SW4) .....	2-5
LEDs .....	2-6
GPIO Status LED (LED1) .....	2-7
SYS_FAULT LED (LED4) .....	2-7
Connectors .....	2-8
JTAG/SWD/SWO Connector (P3) .....	2-10
USB Connector (P4) .....	2-10
USB to UART Connector (P8) .....	2-10
Power Connector (P5) .....	2-11
RF Wireless Connector (J2) .....	2-11
SD Connector (J3) .....	2-11

## ADZS-BF707-BLIP2 BOARD BILL OF MATERIALS

## ADZS-BF707-BLIP2 BOARD SCHEMATIC

## INDEX

# Contents



# PREFACE

Thank you for purchasing the ADZS-BF707-BLIP2 board, Analog Devices, Inc. low-cost evaluation system for the ADSP-BF70x family of Blackfin<sup>®</sup> processors.

The ADSP-BF707 processor is a member of the Blackfin family of products. Blackfin processors combine a dual-MAC state-of-the-art signal processing engine, the advantages of a clean, orthogonal RISC-like microprocessor instruction set, and single-instruction, multiple-data (SIMD) multimedia capabilities into a single instruction-set architecture. New enhancements to the Blackfin+<sup>™</sup> core add 32-bit MAC and 16-bit complex MAC support, cache enhancements, branch prediction and other instruction set improvements, all while maintaining instruction set compatibility to previous Blackfin products.

The ADZS-BF707-BLIP2 board is shipped with all of the necessary hardware—you can start the evaluation immediately. The package contains the standalone evaluation board, CE-approved power supply, and USB cable. The BLIP2 board ships with an ICE-1000 emulator.

A RF Wireless connector is provided for connecting the BLIP2 board to an Analog Devices Wireless Sensor Network (WSN) cluster board (EV-ADRN-WSN-2Z).

The on-board mechanical switches are push buttons.

## Product Overview

The evaluation board is designed to be used in conjunction with the CrossCore<sup>®</sup> Embedded Studio (CCES) development tools to test capabilities of the ADSP-BF70x processors. The development environment aids advanced application code development and debug, such as:

- Create, compile, assemble, and link application programs written in C++, C, and assembly
- Load, run, step, halt, and set breakpoints in application programs
- Read and write data and program memory
- Read and write core and peripheral registers

## Product Overview

The board features:

- Analog Devices ADSP-BF707 processor
  - 184-ball BGA package
- 24 MHz crystal oscillator for processor
- 24 MHz crystal oscillator for USB
- Mobile DDR memory (DMC0) chip
  - 32M bit x 16 x 4 banks (2G bit)
  - MT46H128M16LFDD-48WT
- Quad SPI Flash (SPI2)
  - 32M bit serial flash memory
  - Winbond W25Q32

- CMOS imaging sensors
  - ASX340AT by Aptina / ON Semiconductor and M12 lens holder
  - OVM7692 camera module by Omnivision
- RF Wireless
  - 4 x 2 connector
  - 0.05” socket
- Universal Asynchronous Receiver/Transmitter (UART1)
  - FTDI FT232RQ USB to UART converter
  - USB Mini B connector
- USB interface
  - Micro AB connector
- RESET controller
  - Analog Devices ADM6315 microprocessor supervisory circuits
- Debug (JTAG/SWD/SWO) interface
  - JTAG/SWD/SWO 10-pin 0.05” header for use with Analog Devices emulators
- LEDs
  - Two LEDs: one board status (yellow), one SYS\_FAULT (red)
- Push buttons
  - Four push buttons: one reset, one wake I/O, and two GPIO

## Purpose of This Manual

- External power supply
  - CE compliant
  - 5V @ 3.6 amps
- Other features
  - SD/MMC memory connector
  - 0-ohm resistors for processor current measurement

For information about the hardware components of the BLIP2 board, refer to [ADZS-BF707-BLIP2 Board Bill Of Materials](#).

## Purpose of This Manual

The *ADZS-BF707-BLIP2 Board Evaluation System Manual* provides instructions for installing the product hardware (board). The text describes operation and configuration of the board components and provides guidelines for running your own code on the ADZS-BF707-BLIP2 board. Finally, a schematic and a bill of materials are provided for reference.

## Intended Audience

The primary audience for this manual is a programmer who is familiar with Analog Devices processors. This manual assumes that the audience has a working knowledge of the appropriate processor architecture, instruction set, and C/C++ programming languages.

Programmers who are unfamiliar with Analog Devices processors can use this manual, but should supplement it with other texts (such as the *ADSP-BF70x Blackfin+ Processor Hardware Reference* and the *ADSP-BF70x Blackfin+ Processor Programming Reference*) that describe your target architecture.

Programmers who are unfamiliar with CrossCore Embedded Studio should refer to the CCES online help.

## Manual Contents

The manual consists of:

- Chapter 1, [Using ADZS-BF707-BLIP2 Board](#)  
Describes BLIP2 board functionality from a programmer's perspective and provides a simplified memory map of the processor.
- Chapter 2, [ADZS-BF707-BLIP2 Board Hardware Reference](#)  
Provides information about the BLIP2 board hardware components.
- Appendix A, [ADZS-BF707-BLIP2 Board Bill Of Materials](#)  
Provides a list of hardware components used to manufacture the BLIP2 board.
- Appendix B, [ADZS-BF707-BLIP2 Board Schematic](#)  
Lists the resources for board-level debugging.

## What's New in This Manual

This is the first edition (Revision 1.0) of the *ADZS-BF707-BLIP2 Board Evaluation System Manual*.

# Technical Support

You can reach Analog Devices processors and DSP technical support in the following ways:

- Post your questions in the processors and DSP support community at EngineerZone<sup>®</sup>:  
<http://ez.analog.com/community/dsp>
- Submit your questions to technical support directly at:  
<http://www.analog.com/support>
- E-mail your questions about processors and processor applications to:  
[processor.support@analog.com](mailto:processor.support@analog.com) or  
[processor.china@analog.com](mailto:processor.china@analog.com) (Greater China support)
- Contact your Analog Devices sales office or authorized distributor. Locate one at:  
[www.analog.com/adi-sales](http://www.analog.com/adi-sales)
- Send questions by mail to:  
Processors and DSP Technical Support  
Analog Devices, Inc.  
Three Technology Way  
P.O. Box 9106  
Norwood, MA 02062-9106  
USA

## Supported Processors

This evaluation system supports Analog Devices ADSP-BF707 Blackfin processors.

## Supported Tools

Information on supported tools for the ADZS-BF707-BLIP2 board and the ADSP-BF70x family of processors is:

<http://www.analog.com/BLIP>

## Product Information

Product information can be obtained from the Analog Devices Web site and the online help system.

## Analog Devices Web Site

The Analog Devices Web site, [www.analog.com](http://www.analog.com), provides information about a broad range of products—analog integrated circuits, amplifiers, converters, and digital signal processors.

To access a complete technical library for each processor family, go to [http://www.analog.com/processors/technical\\_library](http://www.analog.com/processors/technical_library). The manuals selection opens a list of current manuals related to the product as well as a link to the previous revisions of the manuals. When locating your manual title, note a possible errata check mark next to the title that leads to the current correction report against the manual.

Also note, [myAnalog.com](http://myAnalog.com) is a free feature of the Analog Devices Web site that allows customization of a Web page to display only the latest information about products you are interested in. You can choose to receive weekly e-mail notifications containing updates to the Web pages that meet your interests, including documentation errata against all manuals. [myAnalog.com](http://myAnalog.com) provides access to books, application notes, data sheets, code examples, and more.

## Notation Conventions

Visit [myAnalog.com](http://myAnalog.com) (found on the Analog Devices home page) to sign up. If you are a registered user, just log on. Your user name is your e-mail address.

## EngineerZone

EngineerZone is a technical support forum from Analog Devices. It allows you direct access to ADI technical support engineers. You can search FAQs and technical information to get quick answers to your embedded processing and DSP design questions.



Use EngineerZone to connect with other DSP developers who face similar design challenges. You can also use this open forum to share knowledge and collaborate with the ADI support team and your peers. Visit <http://ez.analog.com> to sign up.

## Notation Conventions

Text conventions used in this manual are identified and described as follows.

Example	Description
<b>File &gt; Close</b>	Titles in reference sections indicate the location of an item within the CCES environment's menu system (for example, the <b>Close</b> command appears on the <b>File</b> menu).
{this   that}	Alternative required items in syntax descriptions appear within curly brackets and separated by vertical bars; read the example as <i>this</i> or <i>that</i> . One or the other is required.
[this   that]	Optional items in syntax descriptions appear within brackets and separated by vertical bars; read the example as an optional <i>this</i> or <i>that</i> .
[this,...]	Optional item lists in syntax descriptions appear within brackets delimited by commas and terminated with an ellipsis; read the example as an optional comma-separated list of <i>this</i> .



Example	Description
.SECTION	Commands, directives, keywords, and feature names are in text with letter gothic font.
<i>filename</i>	Non-keyword placeholders appear in text with italic style format.
	<p><b>Note:</b> For correct operation, ...</p> <p>A Note provides supplementary information on a related topic. In the online version of this book, the word <b>Note</b> appears instead of this symbol.</p>
	<p><b>Caution:</b> Incorrect device operation may result if ...</p> <p><b>Caution:</b> Device damage may result if ...</p> <p>A Caution identifies conditions or inappropriate usage of the product that could lead to undesirable results or product damage. In the online version of this book, the word <b>Caution</b> appears instead of this symbol.</p>
	<p><b>Warning:</b> Injury to device users may result if ...</p> <p>A Warning identifies conditions or inappropriate usage of the product that could lead to conditions that are potentially hazardous for the devices users. In the online version of this book, the word <b>Warning</b> appears instead of this symbol.</p>

# Notation Conventions

# 1 USING ADZS-BF707-BLIP2 BOARD

This chapter provides information to assist you with development of programs for the ADZS-BF707-BLIP2 evaluation system.

The following topics are covered.

- [Package Contents](#)
- [Default Configuration](#)
- [BLIP2 Board Installation](#)
- [BLIP2 Board Session Startup](#)
- [Evaluation License](#)
- [Mobile DDR Memory](#)
- [SPI Flash](#)
- [UART1 Interface](#)
- [USB Interface](#)
- [SD Interface](#)
- [Debug Interface](#)
- [Power-On-Self Test](#)
- [RF Wireless Interface](#)
- [Power Architecture](#)

## Package Contents

- [Example Programs](#)
- [Reference Design Information](#)

## Package Contents

Your ADZS-BF707-BLIP2 board package contains the following items.

- ADZS-BF707-BLIP2 board
- ICE-1000 emulator
- Tripod
- M12 lens
- Universal 5V DC power
- USB Mini-B to Standard-A cable
- USB Micro-B to Standard-A cable
- Release note

Contact the vendor where you purchased your BLIP2 board or contact Analog Devices, Inc. if any item is missing.

## Default Configuration

The ADZS-BF707-BLIP2 board is designed to run as a standalone unit.

When removing the BLIP2 board from the package, handle the board carefully to avoid the discharge of static electricity, which can damage some components.

The BLIP2 evaluation system contains ESD (electrostatic discharge) sensitive devices. Electrostatic charges readily accumulate on the human body and equipment and can discharge without detection. Permanent damage may occur on devices subjected to high-energy discharges. Proper ESD precautions are recommended to avoid performance degradation or loss of functionality. Store unused BLIP2 boards in the protective shipping package.



## BLIP2 Board Installation

It is assumed that the CrossCore Embedded Studio software is installed and running on your PC.

Follow these instructions to ensure correct operation of the product software and hardware.

**Step 1:** Connect an emulator to the BLIP2 board.

1. Plug one side of the included USB cable into the USB connector of the emulator. Plug the other side into a USB port of the PC.
2. The status LED (labeled *STATUS*) lights up yellow if the connection with the PC is working and the appropriate Windows driver is installed. Please refer to the appropriate emulator manual if the status LED does not turn on.
3. Attach the emulator header (J2) on the bottom of the ICE-1000 to the P3 connector on the BLIP2 board.

## BLIP2 Board Session Startup

**Step 2:** Providing power to the BLIP2 board.

1. Plug one side of the USB Micro-B to Standard-A cable into the USB connector P4 on the BLIP2 board. Plug the other side into a USB port of the PC. If there lacks a USB port to supply power to BLIP2 board, follow the instructions in the next two steps.
2. Plug the jack-end of the assembled power adaptor into the power connector (REFDES) P5 (labeled 5V) on the BLIP2 board.
3. Plug the other side of the power adaptor into a power outlet.

## BLIP2 Board Session Startup

It is assumed that the CrossCore Embedded Studio software is installed and running on your PC.



Note: If you connect the board or emulator first (before installing CCES) to the PC, the Windows driver wizard may not find the board drivers.

1. Navigate to the CCES environment through the **Start** menu.

Note that CCES is not connected to the target board.

2. Use the Debug Configurations wizard to connect to the BLIP2 board.

If a debug configuration exists already, select the appropriate configuration and click **Debug**. Go to step 8.

To create a debug configuration, do one of the following:

- Click the down arrow next to the bug icon , select **Debug Configurations**.
- Choose **Run > Debug Configurations**.

The **Debug Configuration** dialog box appears.

3. Select **CrossCore Embedded Studio Application** and click  (New launch configuration).

The **Select Processor** page of the **Session Wizard** appears.

4. Ensure **Blackfin** is selected in **Processor family**. In **Processor type**, select **ADSP-BF707**. Click **Next**.

The **Select Connection Type** page of the **Session Wizard** appears.

5. Select **Emulator** and click **Next**.

The **Select Platform** page of the **Session Wizard** appears.

6. Choose the type of emulator that is connected to the BLIP2 board.

 An ICE-1000 emulator is included in the package.

7. Click **Finish** to close the wizard.

The new debug configuration is created and added to the **Debug Configurations** list.



8. In the **Name** edit box, users can select an appropriate name to describe the configuration, otherwise a default name is provided.
9. Select the **Custom Board Support** tab and check the **Enable customizations** box. Click on **Browse** and select the **ADZS-BF707-BLIP2-proc.xml** file found in the **ADZS\_BF707\_BLIP2\_Board-Rel1.0.0\Blackfin\Examples** folder.



## Evaluation License

Click **OK**. In the **Run/Debug settings**, click **Apply** to save and apply the changes.

10. In the **Program(s) to load** section, choose the program to load (if the appropriate program is not already populated) when connecting to the board. If not loading any program upon connection to the target, do not make any changes.

 While connected to the target, there is no way to choose a program to download. To load a program once connected, terminate the session and then load the new program.

 To delete a configuration, go to the **Debug Configurations** dialog box and select the configuration to delete. Click  and choose **Yes** when asked if you wish to delete the selected launch configuration. Then **Close** the dialog box.

 To disconnect from the target board, click the terminate button  or choose **Run > Terminate**.

To delete a session, choose **Target > Session > Session List**. Select the session name from the list and click **Delete**. Click **OK**.

 The default configurations that show up in the CCES Debug Configurations wizard are for JTAG mode debugging only. To use SWD mode, create a new platform using the Target Configurator.

## Evaluation License

When starting CCES for the first time, you are prompted to install a license with a serial number or to enable evaluation of the product without a serial number. In the box that contains the EZ-Board is a business card with a serial number on it. When prompted, choose “I have a serial number that I would like to activate” and enter the serial number shown on the card. If the evaluation license is installed but not activated, it allows



10 days of unrestricted use and then becomes disabled. The license can be re-enabled by activation. Once activated, the evaluation license offers unrestricted use for a defined period and then becomes disabled until an additional license is installed.



If installing CCES without using a serial number, you will be limited to 180 days.

An evaluation license can be upgraded to a full license. Licenses can be purchased from:

- Analog Devices directly. Call (800) 262-5645 or 781-937-2384 or go to:  
<http://www.analog.com/buyonline>.
- Analog Devices, Inc. local sales office or authorized distributor. To locate one, go to:  
[www.analog.com/adi-sales](http://www.analog.com/adi-sales).

## Mobile DDR Memory

The ADSP-BF707 processor connects to a 2Gb Micron MT46H128M16 chip through the Double Data Rate Synchronous Dynamic Random-Access Memory controller. The memory controller on the processor and the Mobile DDR memory chip are powered by the on-board 1.8V regulator. The memory controller on the processor can operate at a maximum clock frequency of 200 MHz. Data is transferred between the processor and the memory chip on both the rising and falling edges of the clock.

With a CCES session running and connected to the BLIP2 board through an emulator, the memory controller registers are configured automatically each time the processor is reset through a soft reset using CCES. The values are used whenever mobile DDR chip is accessed through the debugger (for example, when viewing memory or loading a program).

## SPI Flash

To disable the automatic setting of the memory controller registers, select **Target Options** from the **Session** menu in CCES and uncheck **Use XML reset values**.

## SPI Flash

The ADSP-BF707 processor has three SPI interfaces: SPI0, SPI1, and SPI2. SPI2 is connected to a Winbond W25Q32BC 32 Mb serial flash memory with quad SPI support. This flash is used for booting and scratchpad space.

## UART1 Interface

The ADSP-BF707 processor has two built-in universal asynchronous transmitters (UARTs). UART1 is connected to an FTDI, FT232RQ, USB to UART converter IC (U15).

For more information, refer to the UART1 example, which is included in the ADZS-BF707-BLIP2 Board Support Package.

## USB Interface

The ADSP-BF707 processor has an integrated USB PHY; the BLIP2 board provides a micro AB connector. The board supports USB high speed mode.

To learn about the device and host modes of the processor, refer to the USB example, which is included in the ADZS-BF707-BLIP2 Board Support Package. For more information, refer to the *ADSP-BF70x Blackfin+ Processor Hardware Reference*.

# SD Interface

The ADSP-BF707 processor has a secure digital (SD) interface that consists of a clock pin, command pin, card detect pin, and an 8-bit data bus.

# Debug Interface

The BLIP2 board provides a JTAG/SWD/SWO connection through a connector (P3), which is a 0.05” pitch header. A 8-bit trace connection also is available through a connector (P2), although this is not supported at this time. See [JTAG/SWD/SWO Connector \(P3\)](#) for more information.

# Power-On-Self Test

The Power-On-Self-Test Program (POST) tests all BLIP2 board peripherals, except for SD card interface, and validates functionality as well as connectivity to the processor. Once assembled, each BLIP2 board is fully tested for an extended period of time with POST. All BLIP2 boards are shipped with Video Occupancy Sensor real-time applications burned into flash memory. For executing POST code, refer to the `Power_On_Self_Test` example in the Board Support Package.

Note that the source code for the POST program is included in the ADZS-BF707-BLIP2 Board Support Package along with the `readme.txt` file that describes how the board is configured to run POST.

# RF Wireless Interface

A RF Wireless connector allows the BLIP2 board to be connected to an Analog Devices Inc. Wireless Sensor Network (WSN) cluster board EV-ADRN-WSN-2Z. Alternatively, it can be used as a general-purpose

## Power Architecture

connector for the SPI1 port, 3.2V supply, and ground. Note that any SPI1 pin can also be configured as GPIO. For pinout information, go to [ADZS-BF707-BLIP2 Board Schematic](#).

## Power Architecture

The ADZS-BF707-BLIP2 board has three primary voltage domains: 3.2V, 1.1V, and 1.8V. The power input is a 5V wall adaptor.

The Analog Devices ADP2370 voltage regulator provides 3.2V for the VDD\_EXT signal and the 3.2V power requirements of the board. The ADP2230 voltage regulator provides 1.1V for the VDD\_INT signal in addition to providing 1.8V for the VDD\_DMC0 signal. The ADP195 load switch is used to create a collapsible power domain to save power during hibernate mode. The ADP220 voltage regulator provides 2.8V to the CMOS imaging sensors.

## Example Programs

Example programs are provided with the ADZS-BF707-BLIP2 Board Support Package to demonstrate various capabilities of the product. The programs can be found in the ADZS\_BF707\_BLIP2\_Board-Rel1.0.0\Black-fin\Examples folder. The number after the “Rel” could be higher for newer versions. Refer to a readme file provided with each example for more information.

## Reference Design Information

A reference design info package is available for download on the Analog Devices Web site. The package provides information on the design, layout, fabrication, and assembly of the BLIP2 board.

The information can be found at:

<http://www.analog.com/BLIP>

## Reference Design Information

# 2 ADZS-BF707-BLIP2 BOARD HARDWARE REFERENCE

This chapter describes the hardware design of the ADZS-BF707-BLIP2 board.

The following topics are covered.

- [System Architecture](#)  
Describes the board's configuration and explains how the board components interface with the processor.
- [Push Buttons](#)  
Shows the locations and describes the push buttons.
- [LEDs](#)  
Shows the locations and describes the LEDs.
- [Connectors](#)  
Shows the locations and provides part numbers for the on-board connectors. In addition, the manufacturer and part number information is provided for the mating parts.

# System Architecture

This section describes the processor's configuration on the ADZS-BF707-BLIP2 board (Figure 2-1).

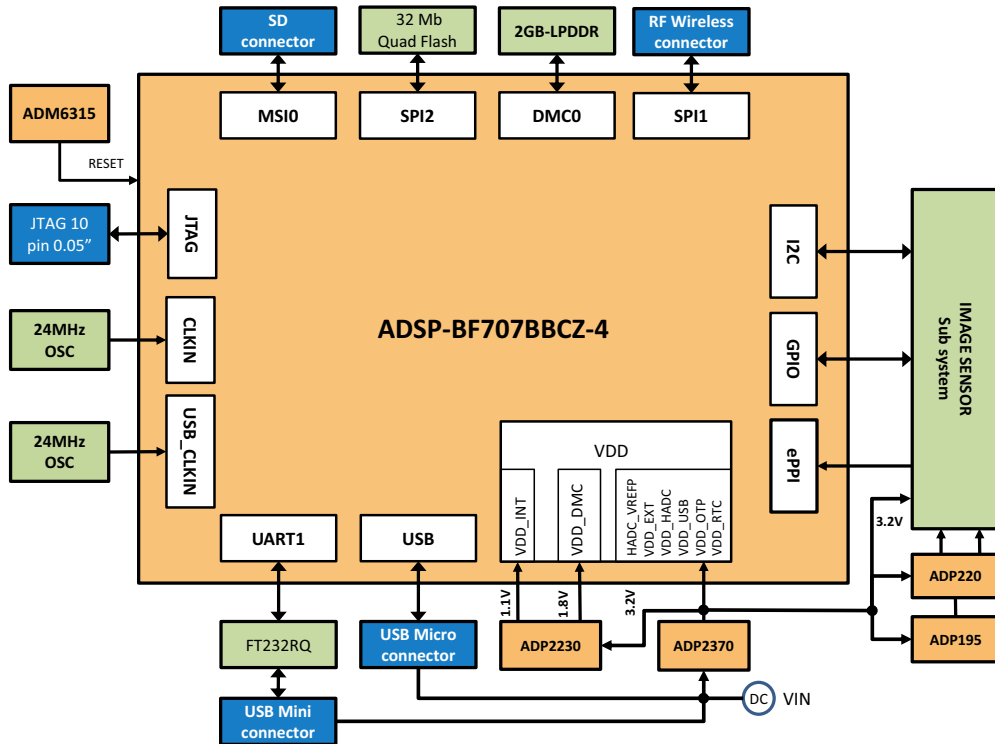

Figure 2-1. BLIP2 Board Block Diagram

The ADZS-BF707-BLIP2 board is designed to demonstrate the image analysis capabilities of the ADSP-BF707 processor. The board houses two imaging sensors. ASX340AT is a CMOS imaging sensor made by Aptina/ON Semiconductor. It is placed underneath a M12 lens holder.



## ADZS-BF707-BLIP2 Board Hardware Reference

OVM7692 is a camera module made by Omnivision. It packages an OV7692 imaging sensor with a lens.

The ADZS-BF707-BLIP2 board has a 24 MHz input clock and runs at 384 MHz internally.

USB circuitry and a micro USB AB connector enable the BLIP2 board to connect to a host. The clock for the USB circuit is generated by a 24 MHz oscillator.

An FT232RQ device from Future Technology Devices International and a USB Mini-B connector allow the UART1 port of the ADSP-BF707 processor to connect to a USB port of a host.

The SD connector enables plug-in of an SD card or a WiFi module that supports SD card interface.

The RF Wireless connector allows the connection of the BLIP2 board to an Analog Devices Inc. Wireless Sensor Network (WSN) Cluster Board. Alternatively, it can be used as a general-purpose connector for the SPI1 port, 3.2V supply, and ground. Note that any SPI1 pin can also be configured as GPIO.

See [ADZS-BF707-BLIP2 Board Schematic](#) and the Wireless Sensor Network (WSN) cluster board EV-ADRN-WSN-2ZWSN for more information.

## Push Buttons

This section describes operation of the push buttons. The push button locations are shown in [Figure 2-2](#).

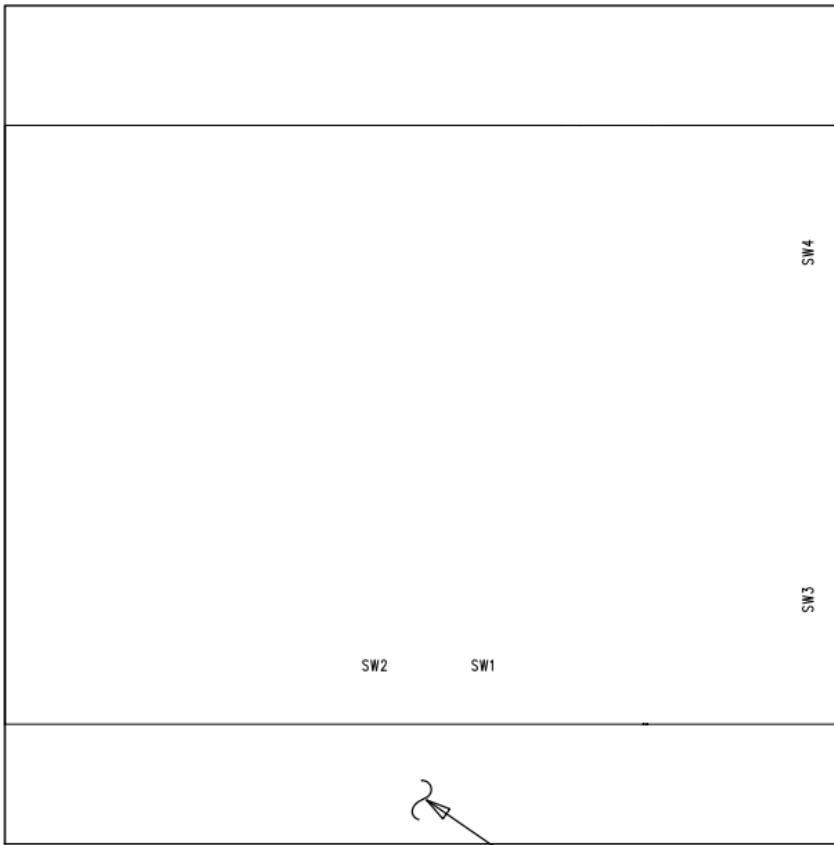

Figure 2-2. Push Button Locations

## GPIO Push Buttons (SW1 and SW2)

The GPIO push buttons (SW1 and SW2) are connected to the processor's signals PC\_11/SPT1\_BFS/MSIO\_D5/SPIO\_SEL3 and PC\_12/SPT1\_BD0/MSIO\_D6, respectively. The signals are used for debugging purposes.

## Reset Push Button (SW3)

The reset push button (SW3) resets the following ICs: processor (U7) and the USB to UART converter (U15).

## WAKE IO Push Button (SW4)

The WAKE IO push button (SW4) wakes up the processor after it goes into hibernate mode.

## LEDs

This section describes the on-board LEDs. [Figure 2-3](#) shows the LED locations.

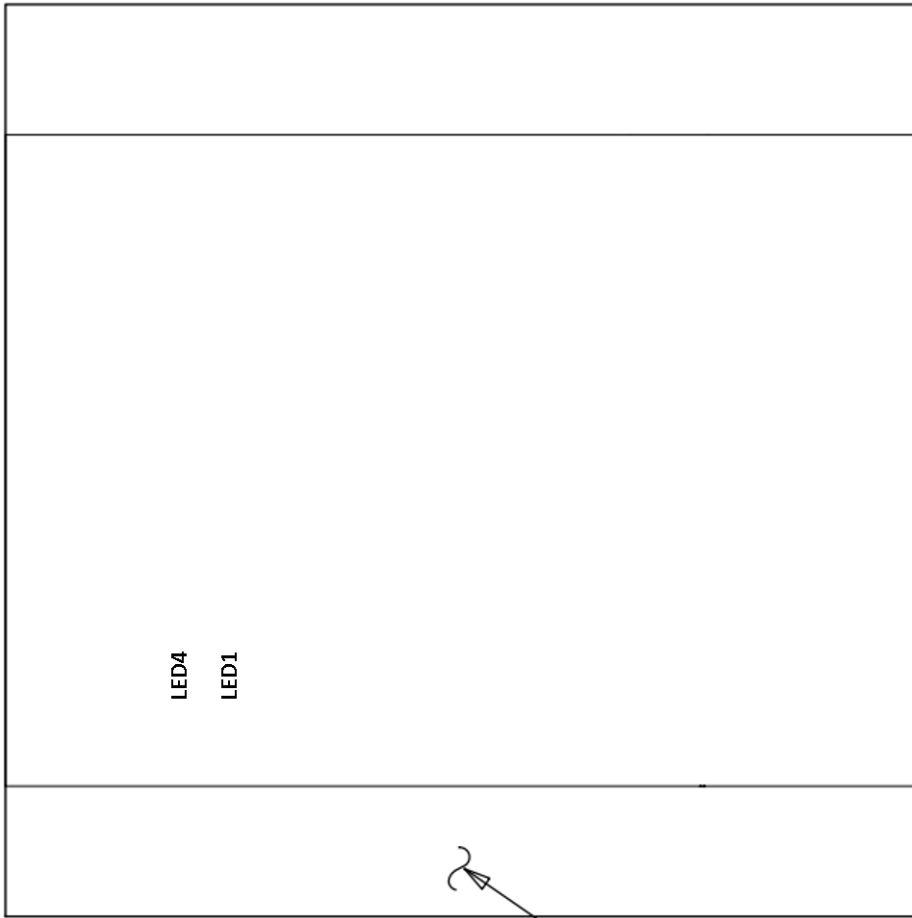

Figure 2-3. LED Locations

## GPIO Status LED (LED1)

When GPIO Status LED (LED1) (yellow) is ON, it indicates the status of the board.

## SYS\_FAULT LED (LED4)

When the SYS\_FAULT LED (LED4) (red) is ON, it indicates a system fault. For more information, refer to the *ADSP-BF70x Blackfin+ Processor Hardware Reference*.

## Connectors

This section describes connector functionality and provides information about mating connectors. The connector locations are shown in [Figure 2-4](#) and [Figure 2-5](#).

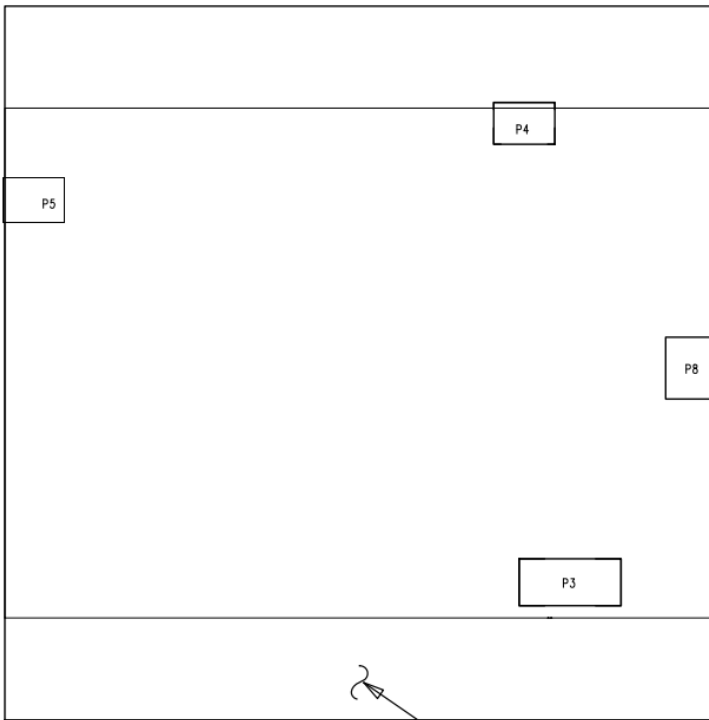

Figure 2-4. Connector Locations, Top

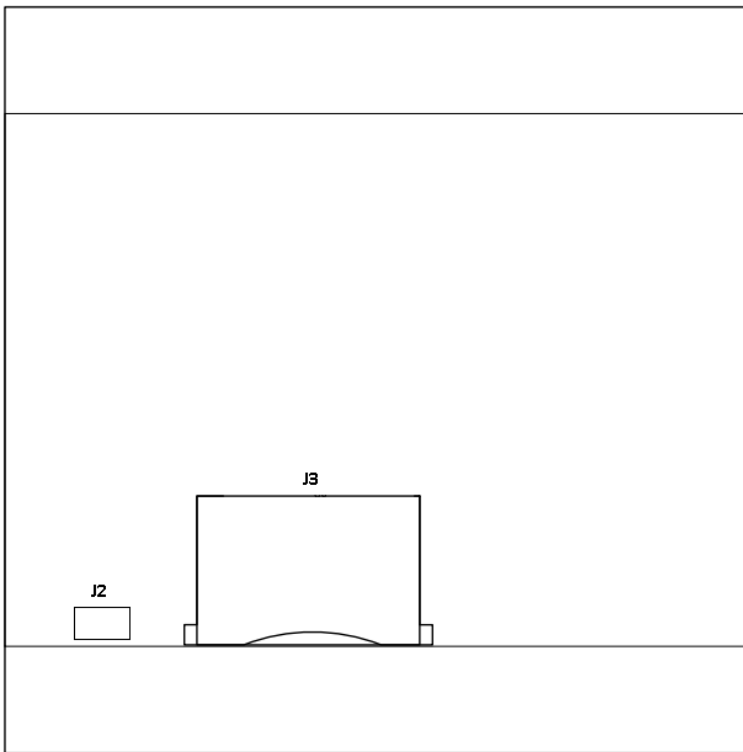

Figure 2-5. Connector Locations, Bottom

## Connectors

### JTAG/SWD/SWO Connector (P3)

The JTAG/SWD/SWO header (P3) provides debug connectivity for the processor. This is a 0.05” shrouded through-hole connector from SAMTEC (SAMTEC\_SHF-105-01-L-D-SM-K). This connector mates with ICE-1000, ICE-2000, and any newer Analog Devices emulators. For more information, see [Debug Interface](#).

### USB Connector (P4)

Part Description	Manufacturer	Part Number
USB Micro-AB	Hirose	ZX62D-AB-5P8
<b>Mating Cable</b>		
Any USB Micro-B to Standard-A or Micro-A to Standard-A receptacle cable		

### USB to UART Connector (P8)

Part Description	Manufacturer	Part Number
USB Mini-B	Hirose	UX60SC-MB-5S8
<b>Mating Cable</b>		
Any USB Mini-B to Standard-A cable		



## Power Connector (P5)

Part Description	Manufacturer	Part Number
0.65 mm power jack	CUI	045-0883R
<b>Mating Cable</b>		
5.0VDC@3.6A power supply	GLOBETEK	GS-1750(R)

## RF Wireless Connector (J2)

Part Description	Manufacturer	Part Number
4 x 2 0.05" pitch socket	SAMTEC	SFMC-104-T1-L-D
<b>Mating Connector</b>		
4 x 2 0.05" pitch header	SAMTEC	FTSH-104-04-F-D

## SD Connector (J3)

Part Description	Manufacturer	Part Number
SD 8-bit, 2 GB	SANDISK	MHC-W21-601
<b>Mating Connector</b>		
2 GB	SANDISK	SDSDB-2048-A11

## Connectors

# A ADZS-BF707-BLIP2 BOARD BILL OF MATERIALS

The bill of materials corresponds to [ADZS-BF707-BLIP2 Board Schematic](#).

Ref.	Qty.	Description	Reference Designator	Manufacturer	Part Number
1	1	SN74LVC1G08 SOT23-5	U11	TI	SN74LVC1G08DBVE
2	1	24MHZ OSC013	Y1	DIGI-KEY	535-9138-2-ND
3	1	24MHZ OSC013	Y2	DIGI-KEY	535-9138-2-ND
4	1	W25Q32 SO8W	U8	WINBOND	W25Q32FVSSIG
5	1	FT232RQ QFN50P500X500-33NA	U15	DIGI-KEY	768-1008-1-ND
6	1	ADP2230 DFN50P300X300-11N	U13	ANALOG DEVICES	ADP2230
7	1	ADP2370ACPZ-R7 DFN50P300X300-9N	U1	ANALOG DEVICES	ADP2370ACPZ-R7
8	1	LTC6993CS6-3 SOT95P280-6N	U12	LINEAR TECH	LTC6993CS6-3#TRMPBF
9	1	OVM7692-RACA BGA25C50X54P5X5_282 X318	U4	OMNIVISION TECH	OVM7692-RACA
10	1	SN74LVC2G14DCKRQ1 SOT65P210-6N	U14	DIGI-KEY	296-13011-1-ND
11	1	ASX340AT2C00XPED0 BGA63C65P8X8_7500X7 500_SCKT	U10	APTINA	ASX340AT2C00XPED0

Ref.	Qty.	Description	Reference Designator	Manufacturer	Part Number
12	1	ADP195 DFN65P200X200-7N	U5	ANALOG DEVICES	ADP195ACPZ-R7
13	1	ADM6315 SOT143	U3	ANALOG DEVICES	ADM6315-29D2ARTZR7
14	1	ADP220ACBZ-2828R7 BGA6C50P2X3_100X150	VR1	ANALOG DEVICES	ADP220ACBZ-2828R7
15	1	ADSP-BF707 BGA184C80P14X14_120 0X1200_SCKT	U7	ANALOG DEVICES	ADSP-BF707BBCZ-4
16	1	PWR .65MM CON045	P5	DIGI-KEY	CP1-023-ND
17	2	MOMENTARY SWT024	SW3,SW4	PANASONIC	EVQ-Q2K03W
18	2	MOMENTARY SWT024	SW1,SW2	PANASONIC	EVQ-Q2K03W
19	1	SD_CONN 8-BIT CON067	J3	MORETHA- NALL	MHC-W21-601-LF
20	1	USB 5PIN CON069	P8	DIGI-KEY	H11589CT-ND
21	1	USB-MICRO 5PIN HIROSE_ZX62D-AB-5P8	P4	DIGI-KEY	H11494CT-ND
22	1	0.05 10PIN SAM- TEC_SHF-105-01-L-D-S M-K	P3	SAMTEC	SHF-105-01-L-D-SM-K-TR
23	1	IDC 4x2 SAMTEC_S- FMC-104-T1-L-D	J2	SAMTEC	SFMC-104-T1-L-D
24	1	2A FAST 0603	F1	BOURNS INC	SF-0603F200-2
25	1	0 1/4W 5% 1206	R151	KOA	0.0ECTRk7372BTTED
26	2	0 1/4W 5% 1206	R83,R98	KOA	0.0ECTRk7372BTTED
27	3	1UF 16V 10% 0805 X7R	C90,C109,C110	DIGI-KEY	399-1284-2-ND
28	1	0 1/8W 5% 0805	R22	VISHAY	CRCW08050000Z0EA
29	2	2.2UH 10% 0805	L2,L3	DIGI-KEY	490-1119-2-ND

## ADZS-BF707-BLIP2 Board Bill Of Materials

Ref.	Qty.	Description	Reference Designator	Manufacturer	Part Number
30	2	1000PF 50V 10% 0805 X7R	C1,C3	DIGI-KEY	311-1136-2-ND
31	3	0.1UF 10V 10% 0402 X5R	C68,C101,C114	AVX	0402ZD104KAT2A
32	41	0.1UF 10V 10% 0402 X5R	C4-C8,C20-C25, C27,C38-C44,C54,C84-C89,C91-C100,C102,C104,C116,C118,C119	AVX	0402ZD104KAT2A
33	34	0.01UF 16V 10% 0402 X7R	C9-C16,C19,C26, C28-C31,C33-C37,C45,C46,C48,C49,C51,C52,C55-C58,C60,C62,C67,C112,C115	AVX	0402YC103KAT2A
34	35	10K 1/16W 5% 0402	R5,R10,R11,R14, R19,R20,R29,R35, R36,R38,R39,R42,R43,R46,R47,R61,R71,R80,R81, R90,R91,R96,R103-R105,R107,R110-R112,R117-R121,R143	VISHAY	CRCW040210K0FKED
35	5	10K 1/16W 5% 0402	R30,R57,R77,R78, R84	VISHAY	CRCW040210K0FKED
36	3	0 1/10W 5% 0402	R37,R92,R147	PANASONIC	ERJ-2GE0R00X
37	35	0 1/10W 5% 0402	R1-R4,R6-R9,R23, R24,R26,R31,R44,R50,R60,R63-R68,R70,R73,R74, R79,R124,R127,R129-R131,R136-R138,R140,R148	PANASONIC	ERJ-2GE0R00X

Ref.	Qty.	Description	Reference Designator	Manufacturer	Part Number
38	6	0 1/10W 5% 0402	R32,R93,R126,R128,R142,R150	PANASONIC	ERJ-2GE0R00X
39	4	0 1/10W 5% 0402	R33,R34,R125,R141	PANASONIC	ERJ-2GE0R00X
40	15	33 1/16W 5% 0402	R15-R18,R40,R41,R62,R85-R87,R106,R152-R155	VISHAY	CRCW040233R0JNED
41	2	1UF 16V 10% 0603 X5R	C103,C105	DIG01	399-5090-2-ND
42	2	4.7UF 25V 20% 0805 X5R	C61,C117	AVX	0805ZD475KAT2A
43	1	4.7UF 6.3V 20% 0603 X5R	C83	AVX	06036D475MAT2A
44	2	330 1/10W 5% 0603	R25,R72	DIG01	541-330GTR-ND
45	2	1M 1/10W 5% 0603	R21,R146	VISHAY	CRCW06031M00JNEA
46	1	0.0 1/10W 1% 0603	R149	PHYCOMP	232270296001L
47	2	1UF 6.3V 20% 0402 X5R	C106,C107	MURATA	GRM155R60J105ME19D
48	3	100 1/16W 5% 0402	R13,R88,R89	DIGI-KEY	311-100JRTR-ND
49	1	VARISTOR V5.5MLA 30A 0603	R12	LITTLEFUSE	V5.5MLA0603
50	1	PTC 0.5A 1206	R55	LITTLEFUSE	1206L050-C
51	1	47.0K 1/16W 1% 0402	R108	ROHM	MCR01MZPF4702
52	1	10.0K 1/16W 1% 0402	R56	DIGI-KEY	541-10.0KLCT-ND
53	2	100K 1/16W 5% 0402	R101,R102	DIGI-KEY	541-100KJTR-ND
54	4	0 1/16W 5% RNS003	RN2-RN4,RN17	PANASONIC	EXB-2HVR000V
55	1	422K 1/10W 1% 0603	R48	PANASONIC	ERJ-3EKF4223V
56	3	1A MBR130LSFT1G SOD-123FL	D2,D5,D9	ON SEMI	MBR130LSFT1G
57	2	18PF 50V 5% 0402 NP0	C63,C64	MURATA	GRM1555C1H180JA01D

## ADZS-BF707-BLIP2 Board Bill Of Materials

Ref.	Qty.	Description	Reference Designator	Manufacturer	Part Number
58	2	18PF 50V 5% 0402 NP0	C65,C66	MURATA	GRM1555C1H180JA01D
59	10	33 1/32W 5% RNS005	RN6-RN15	PANASONIC	EXB-28V330JX
60	1	30A GSOT05 SOT23-3	D1	VISHAY	GSOT05-E3-08
61	2	2.2K 1/10W 5% 0402	R27,R28	PANASONIC	ERJ-2GEJ222X
62	1	25.5K 1/16W 1% 0402	R54	PANASONIC	ERJ-2RKF2552X
63	2	15KV ESD7004 DFN50P250X100-10N	D4,D8	ON SEMI	ESD7004MUTAG
64	2	15KV ESDA6V1SC SOT95P280-6N	D3,D7	DIGI-KEY	497-6637-1-ND
65	1	4.12K 1/10W 1% 0402	R49	PANASONIC	ERJ-2RKF4121X
66	4	10UF 6.3V 20% 0603 X5R	C69,C70,C76,C79	DIGI-KEY	490-3896-2-ND
67	1	10.2K 1/16W 1% 0402	R51	DIGI-KEY	541-10.2KLTR-ND
68	1	RED LED_0603	LED4	DIGI-KEY	475-2512-2-ND
69	1	YELLOW LED_0603	LED1	DIGI-KEY	475-2558-1-ND
70	9	10UF 6.3V 20% 0402 X5R	C17,C18,C32,C47,C50,C53,C59,C108,C111	DIGI-KEY	445-8920-1-ND
71	1	10UF 6.3V 20% 0402 X5R	C113	DIGI-KEY	445-8920-1-ND
72	2	10UF 35V 20% 0805 X5R ZZZ	C2,C80	DIGI-KEY	445-14420-2-ND
73	1	250ohm NA% IND_DL- W5BT	L4	MOUSER	81-DLW5BTN251SQ2L
74	1	0.8A BSR16 SOT95P240-3N	Q1	FAIRCHILD SEMI	BSR16
75	4	470 1A 0603	FER1,FER2,FER4,FER5	DIGI-KEY	490-5223-2-ND
76	1	470 1A 0603	FER6	DIGI-KEY	490-5223-2-ND

Ref.	Qty.	Description	Reference Designator	Manufacturer	Part Number
77	1	187.0K 1/16W 1% 0402	R45	DIGI-KEY	311-187KLRTR-ND
78	2	560.0K 1/10W 1% 0402	R52,R58	PANASONIC	ERJ-2RKF5603X
79	1	453.0K 1/10W 1% 0402	R53	PANASONIC	ERJ-2RKF4533X
80	1	6.8uH 20% SMT	L1	COILCRAFT	XAL4030-682MEC
81	1	2GB LPDDR	U2	MICRON	MT46H128M16LFDD-48 WT



A

B

C

D

# BLIP2 SCHEMATIC

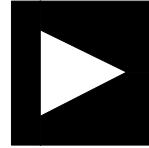
		<b>ANALOG DEVICES</b>	20 Cotton Road Nashua, NH 03063 PH: 1-800-ANALOGD
<b>Title</b>		BLIP2	
<b>Size</b> C	<b>Board No.</b>	A0573-2013	<b>Rev</b> 1.0
<b>Date</b>	02/05/15	<b>Sheet</b>	1 of 10

A

B

C

D

1

1

2

2

3

3

4

4

1

1

2

2

3

3

4

4

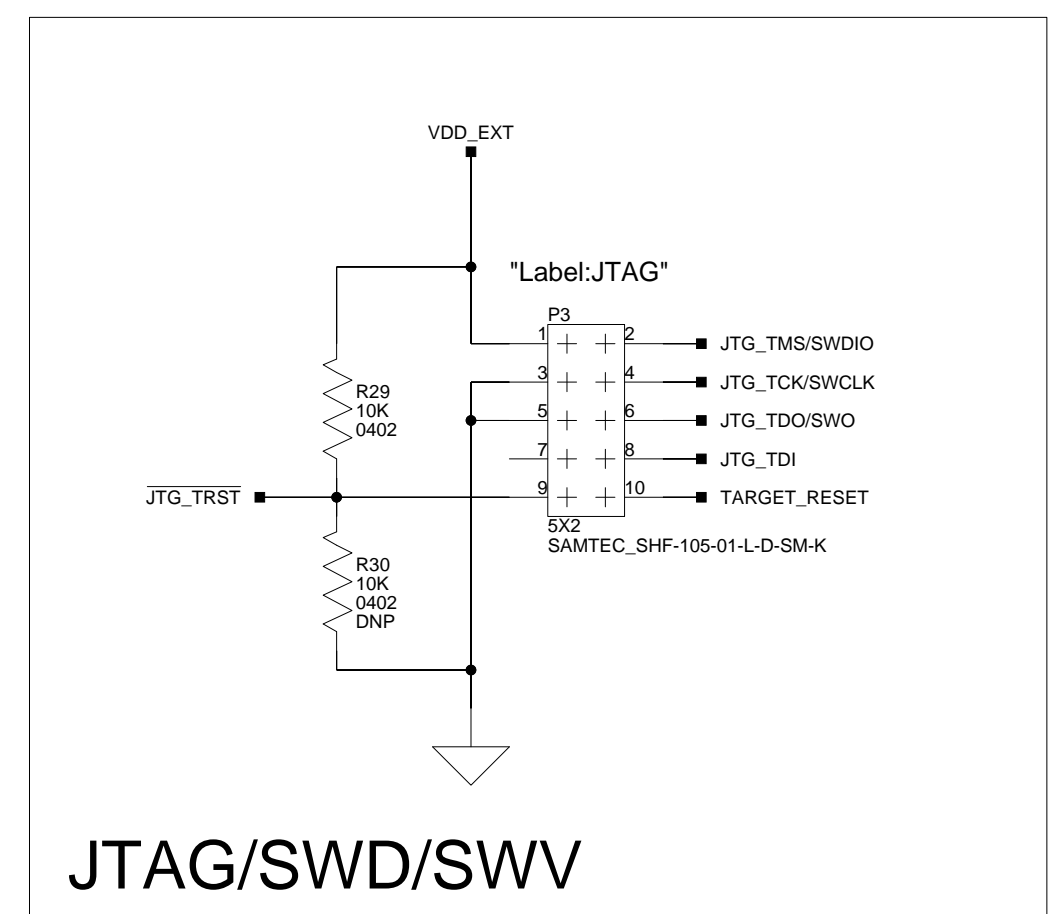
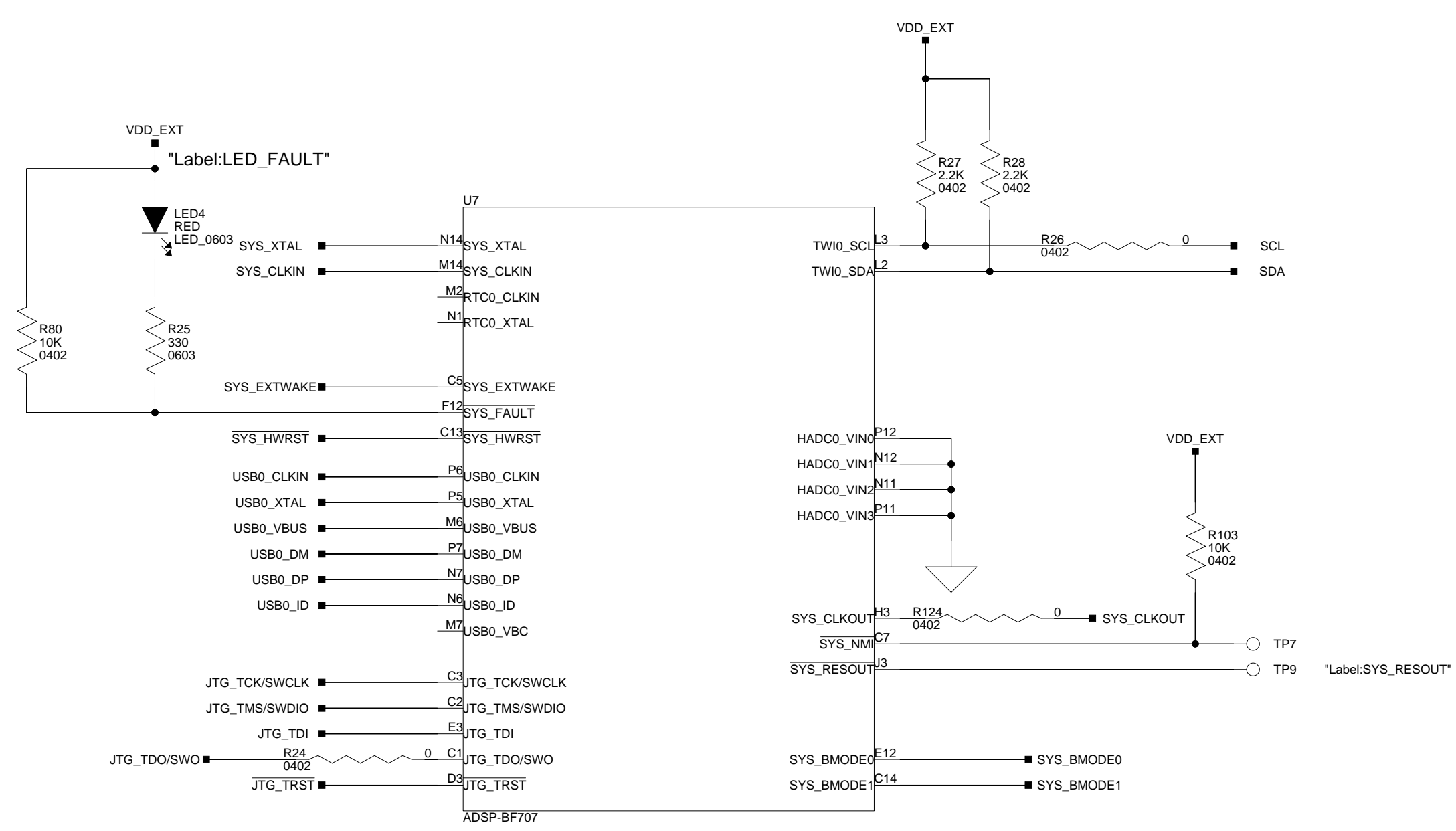
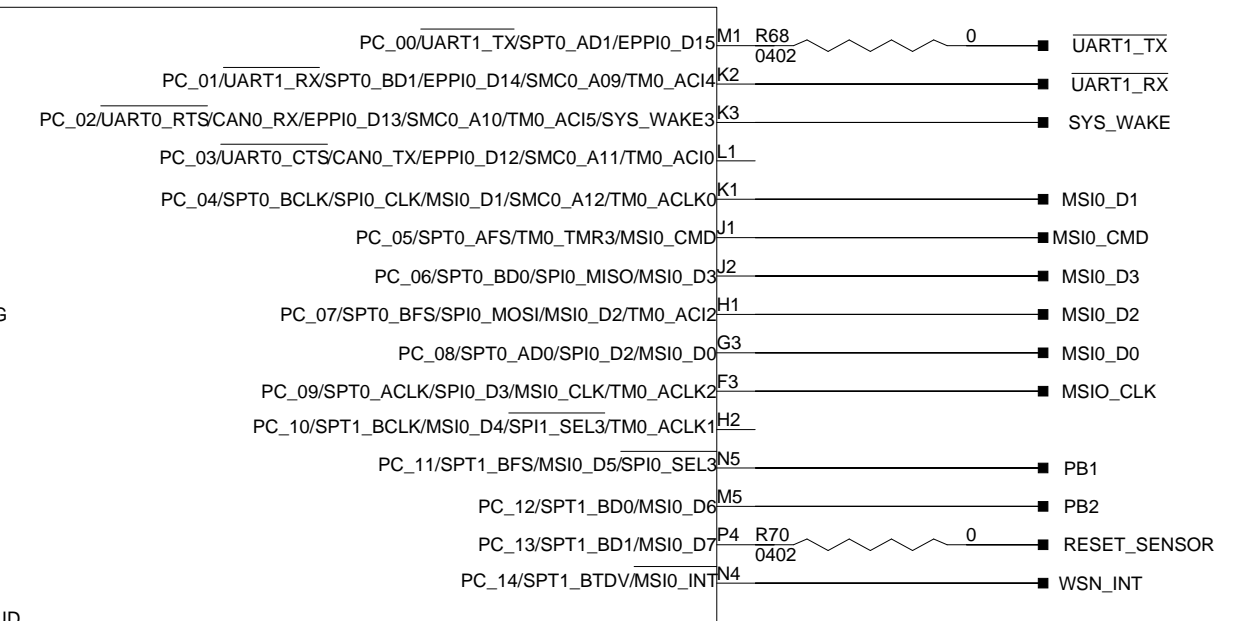
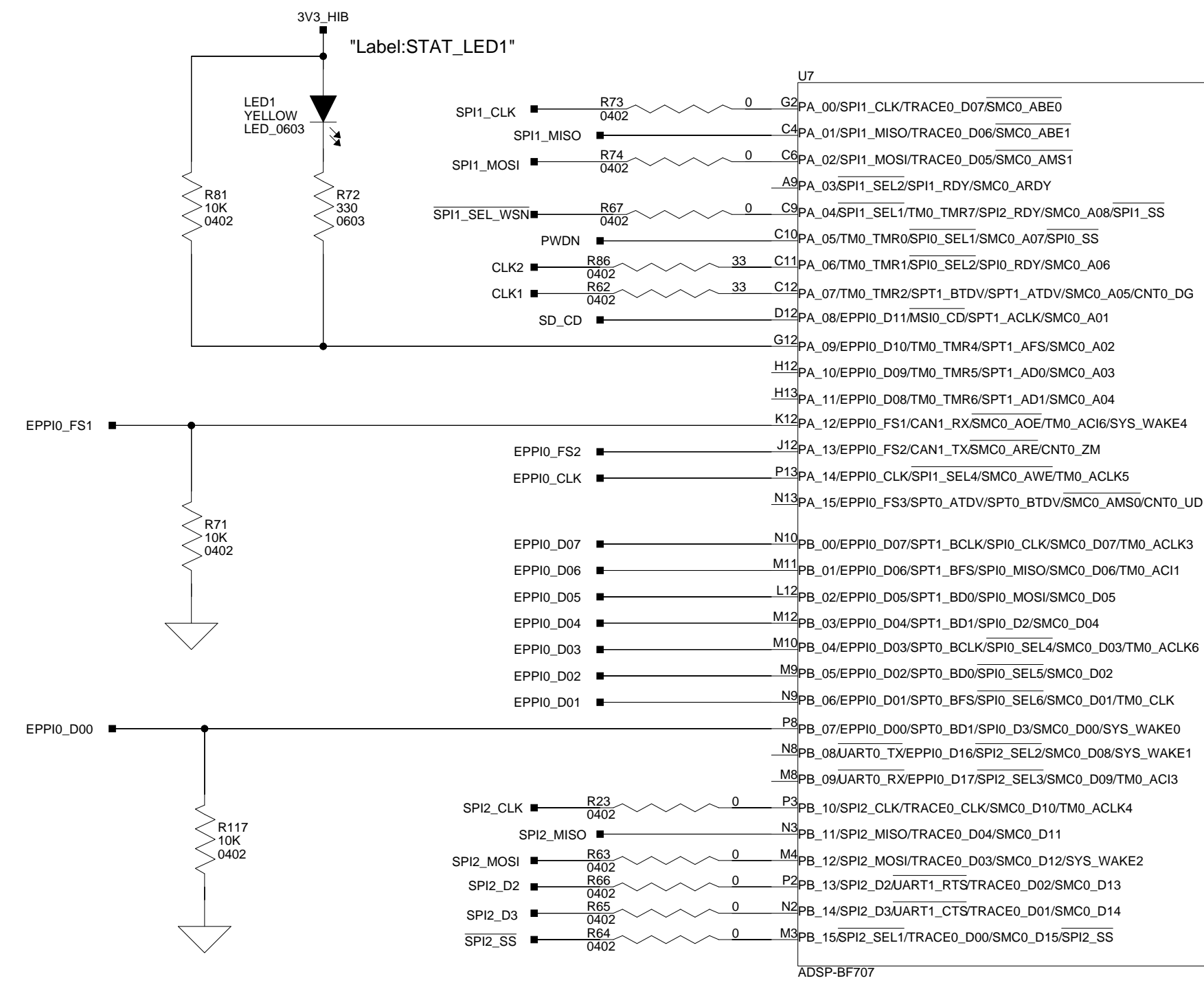

**ANALOG DEVICES**

20 Cotton Road  
Nashua, NH 03063  
PH: 1-800-ANALOGD

<b>Title</b>		
BLIP2 DSP MEMORY, JTAG		
<b>Size C</b>	<b>Board No.</b>	<b>Rev</b>
	A0573-2013	1.0
<b>Date</b>	02/05/15	<b>Sheet</b> 2 <b>of</b> 10

# 2GB LPDDR 32 Meg x 16 x 4 Banks

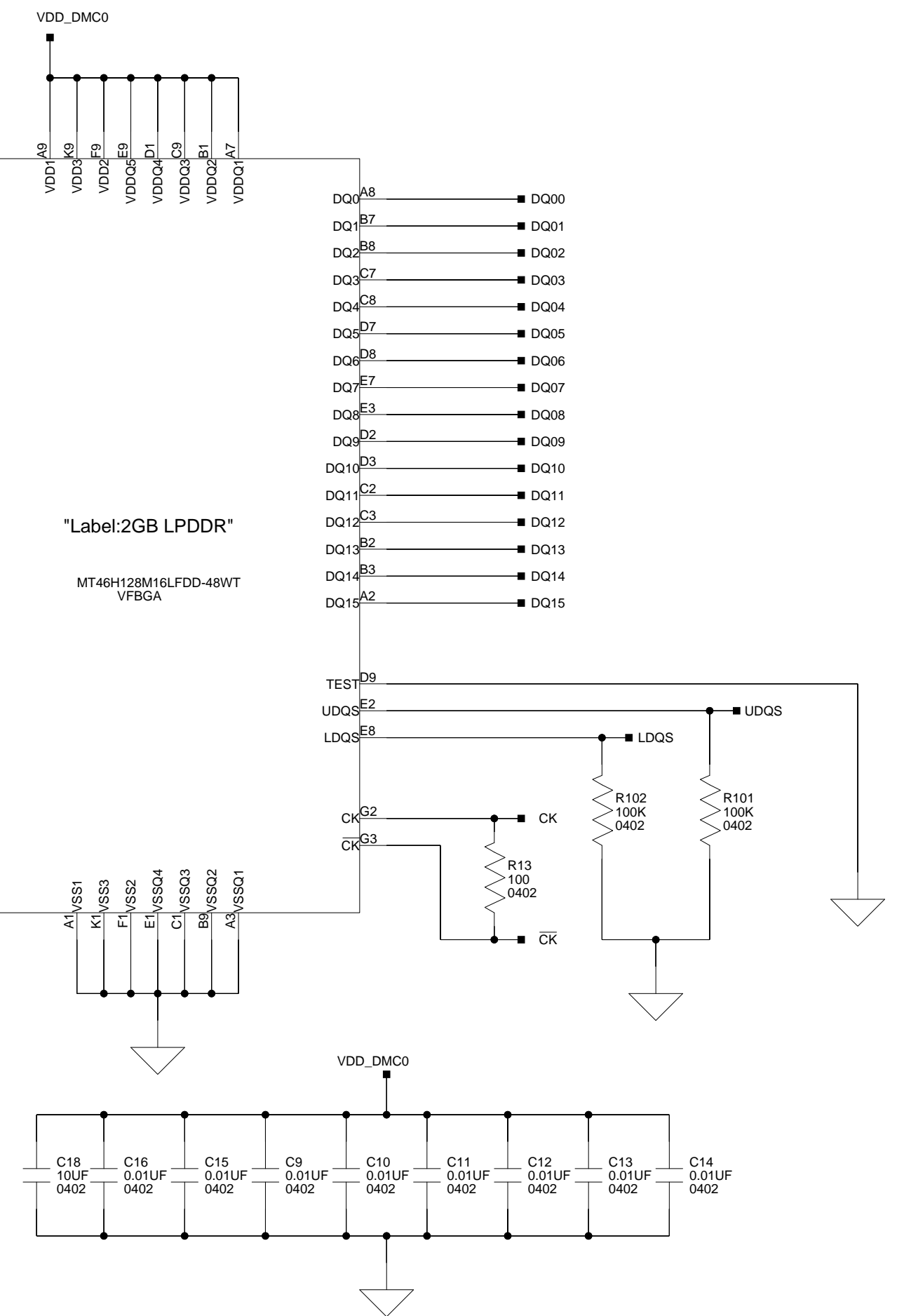
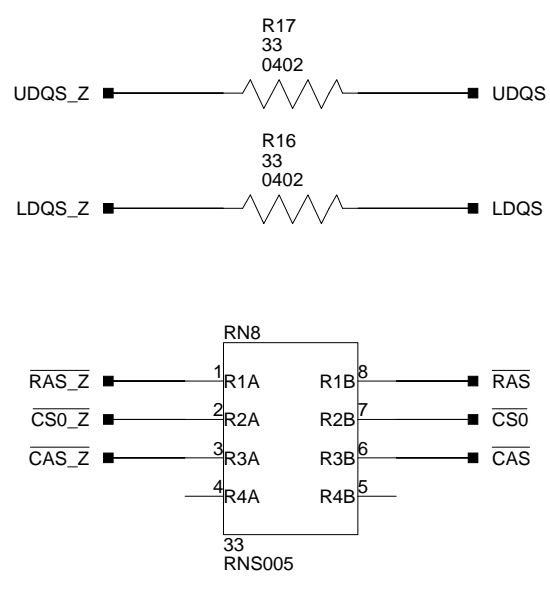
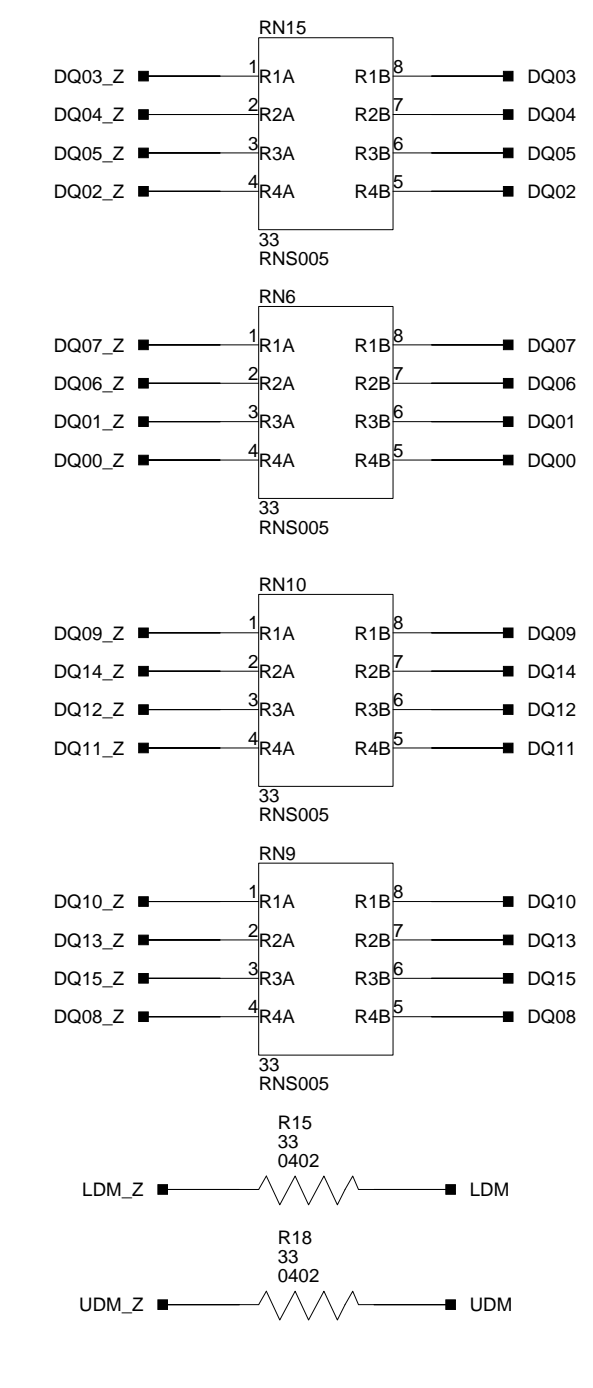
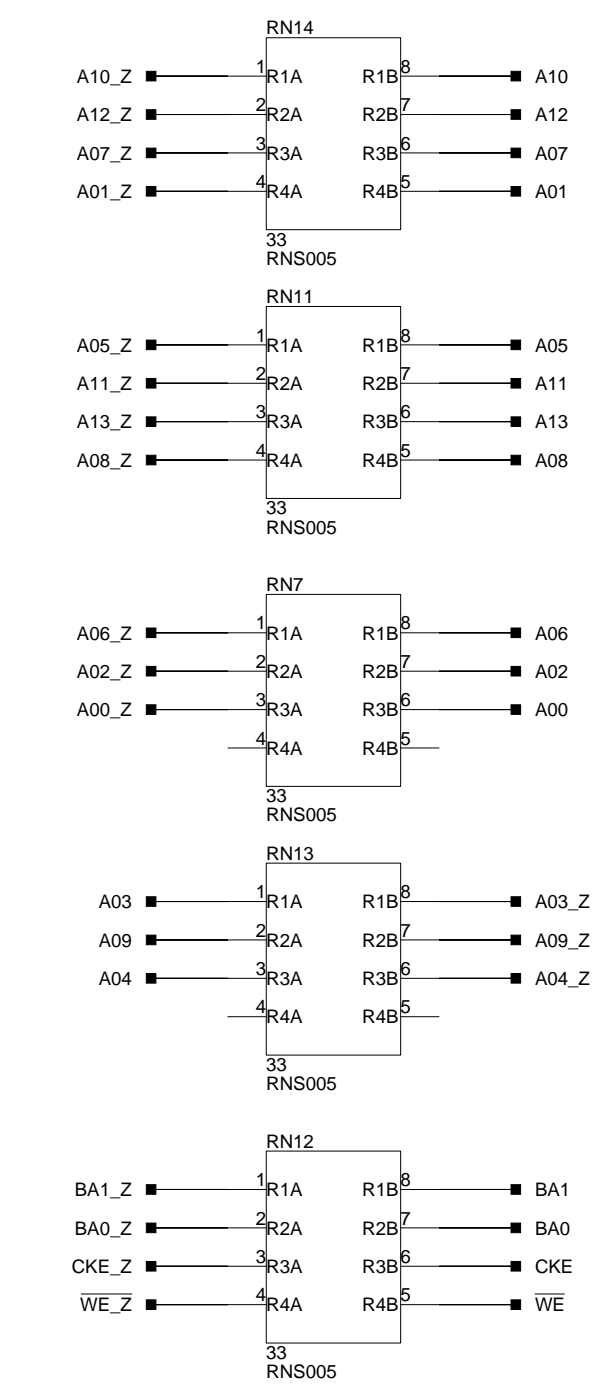
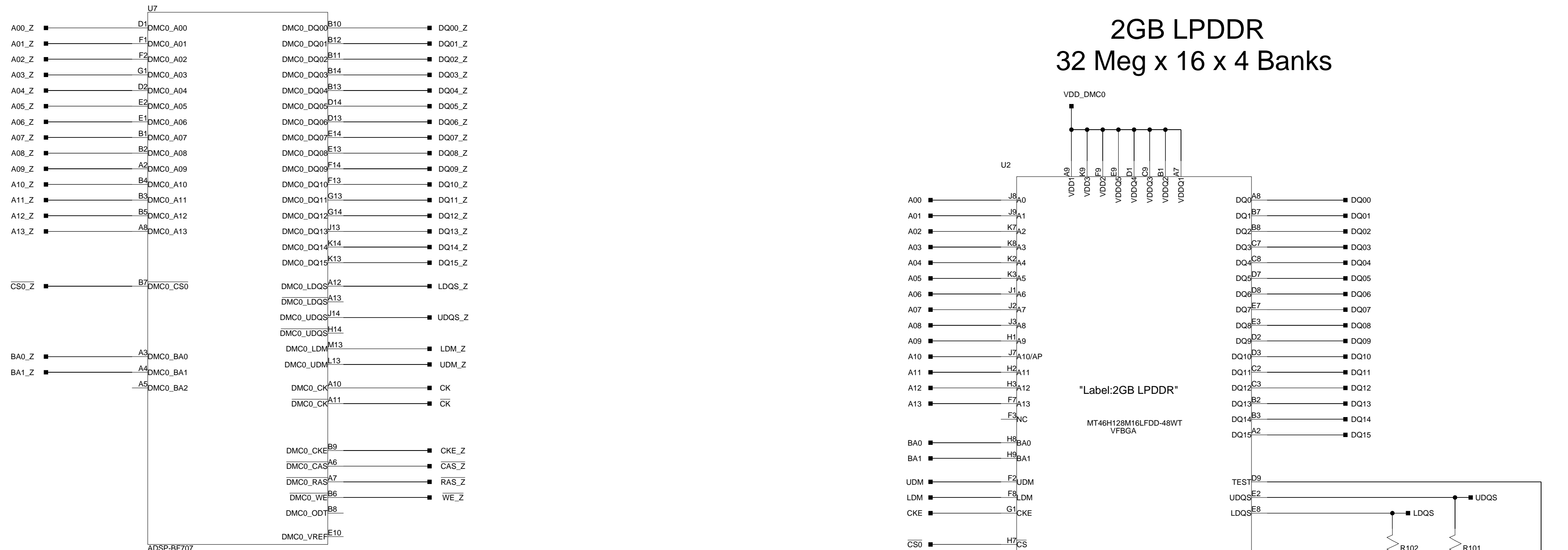

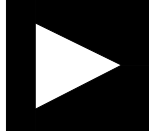
 <b>ANALOG DEVICES</b>		20 Cotton Road Nashua, NH 03063 PH: 1-800-ANALOGD	
		Title <b>BLIP2 DSP SIGNAL, LPDDR MEMORY</b>	
Size C	Board No. <b>A0573-2013</b>	Rev <b>1.0</b>	
Date <b>02/05/15</b>	Sheet <b>3</b> of <b>10</b>		

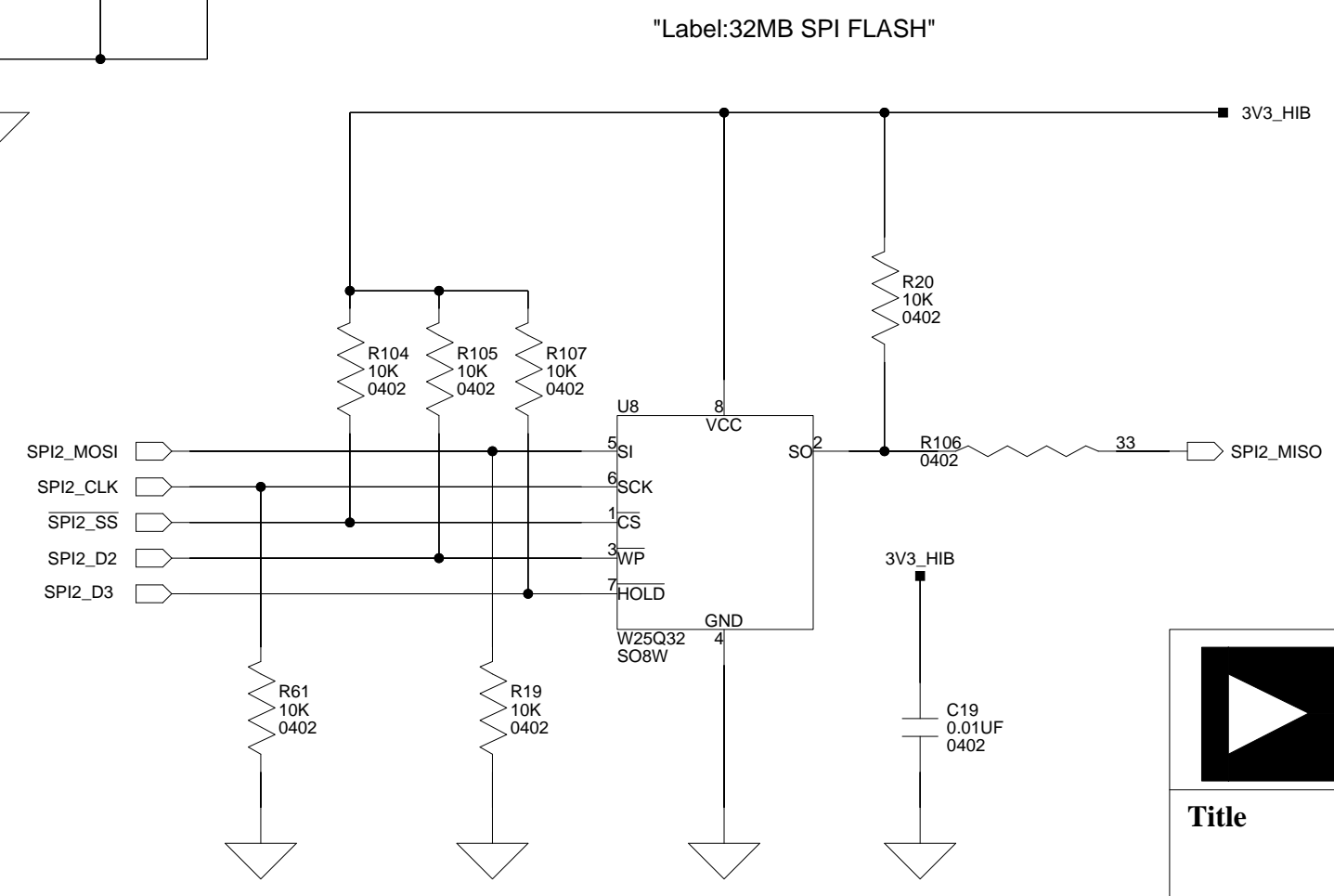
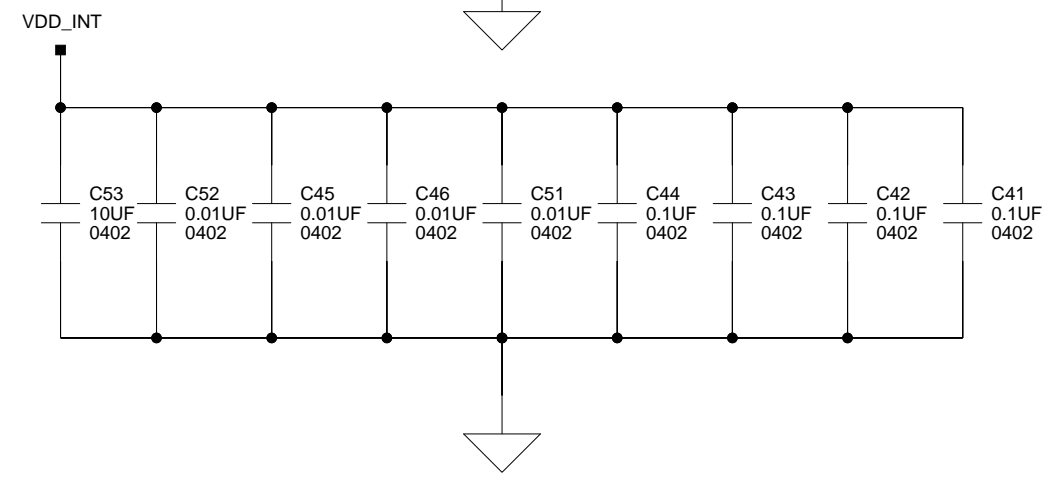
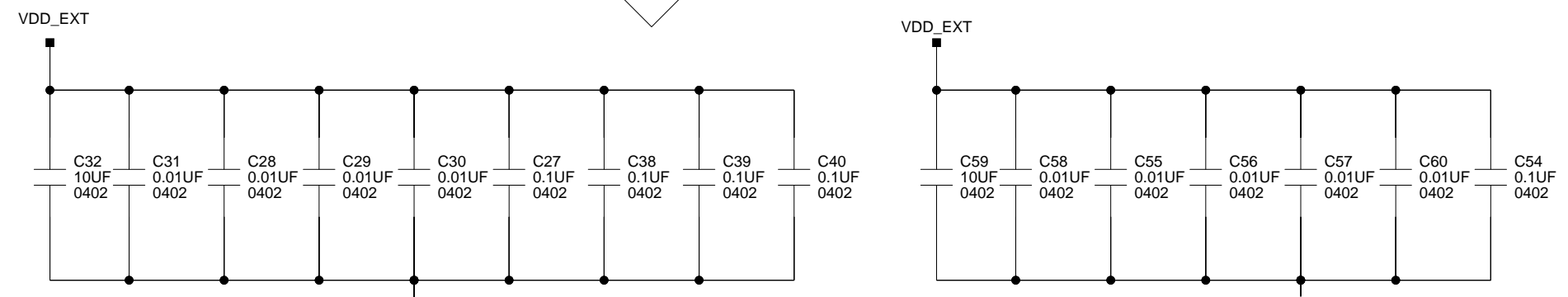
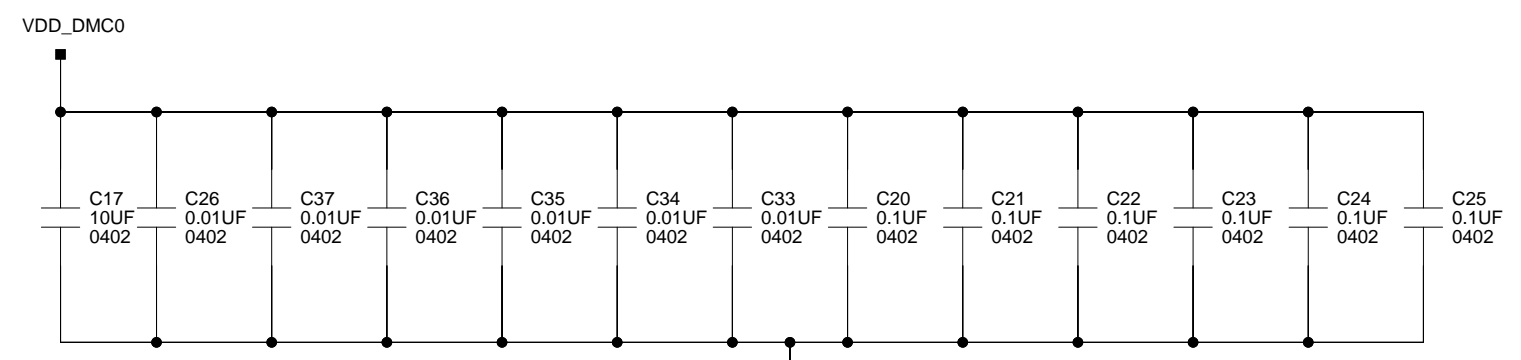
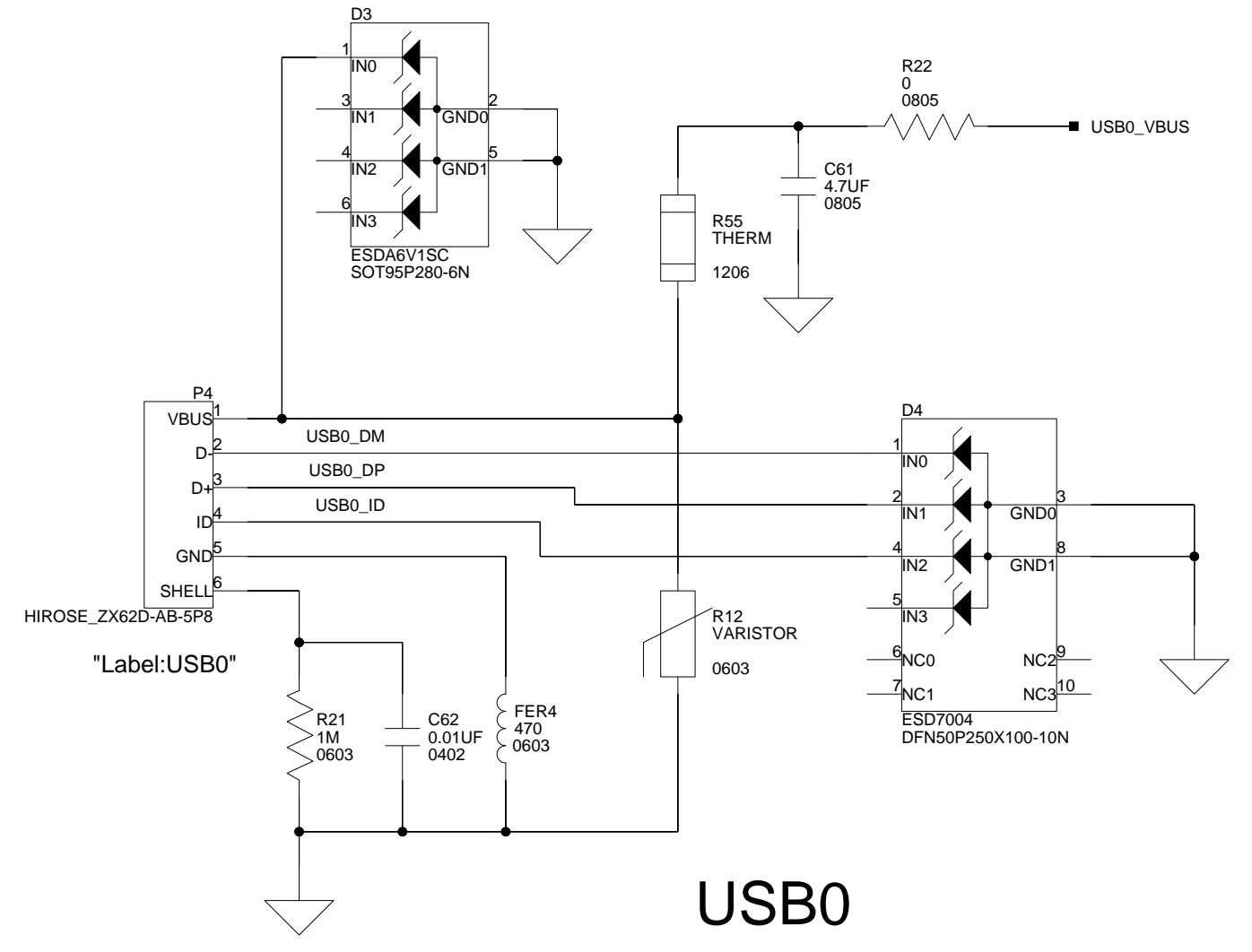
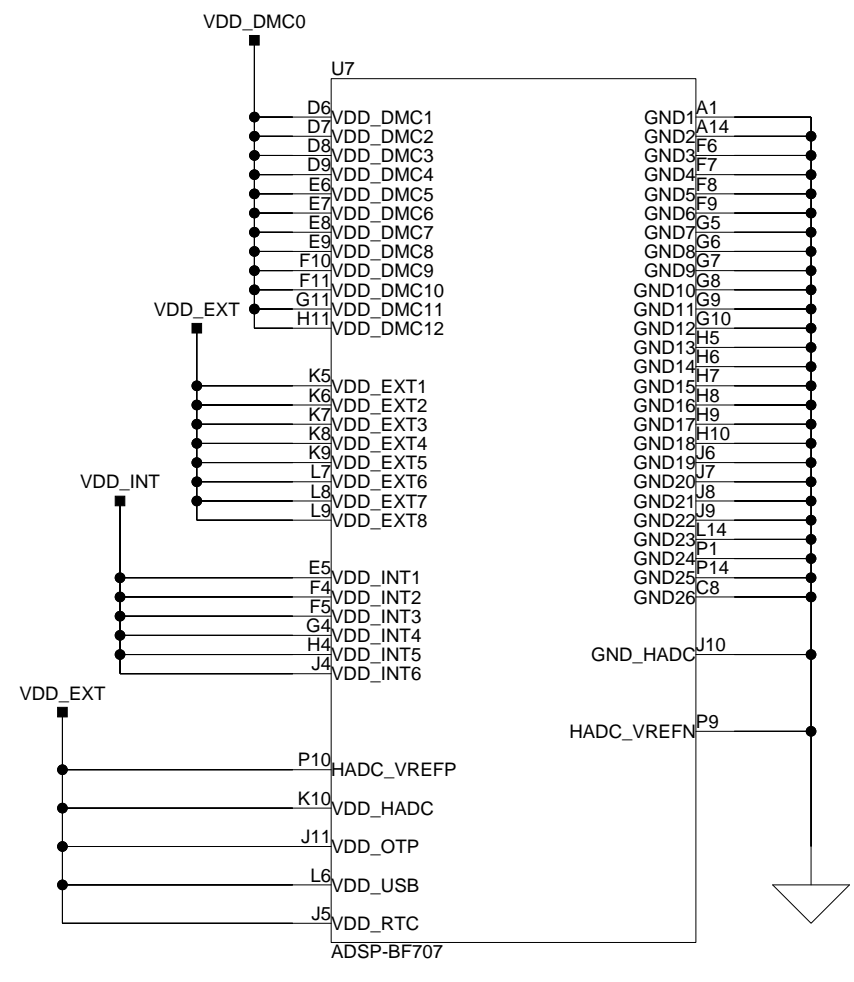

32MB SPI FLASH

		20 Cotton Road Nashua, NH 03063 PH: 1-800-ANALOGD	
<b>Title</b> BLIP2 DSP-POWER, USB, SPI FLASH			
<b>Size C</b>	<b>Board No.</b> A0573-2013	<b>Rev</b> 1.0	
<b>Date</b> 02/05/15	<b>Sheet</b> 4		<b>of</b> 10

# DSP\_XTAL

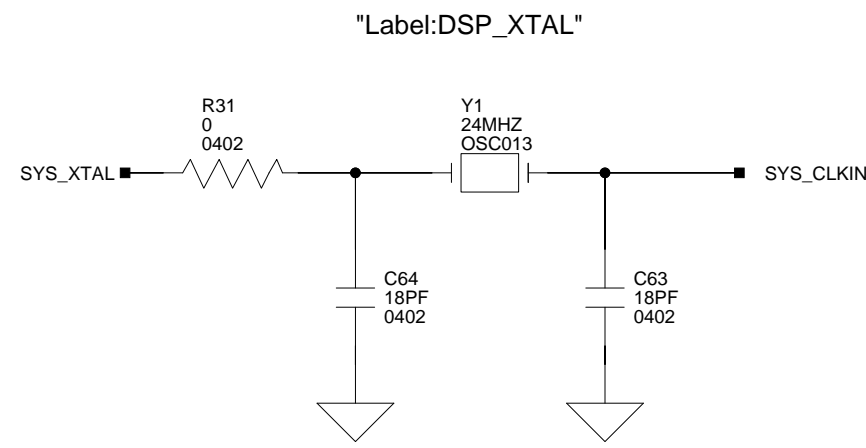

# USB\_XTAL

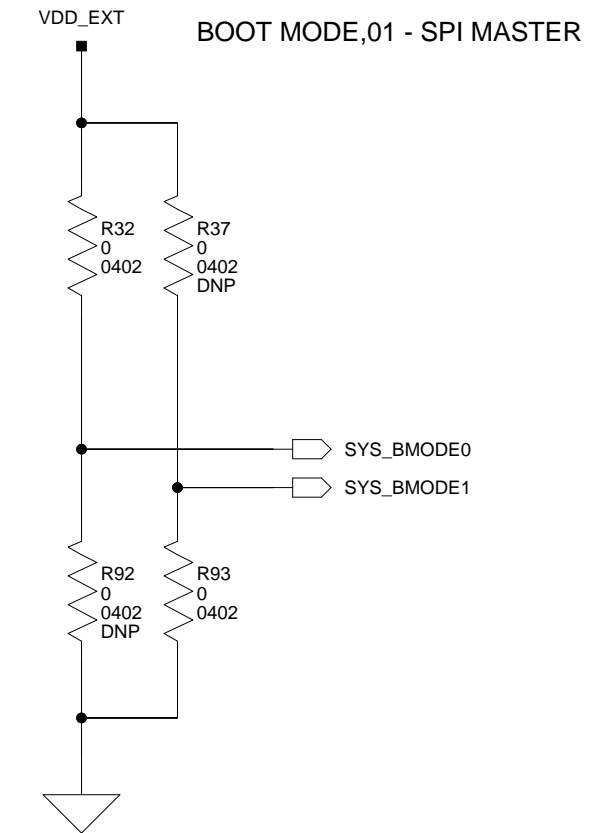
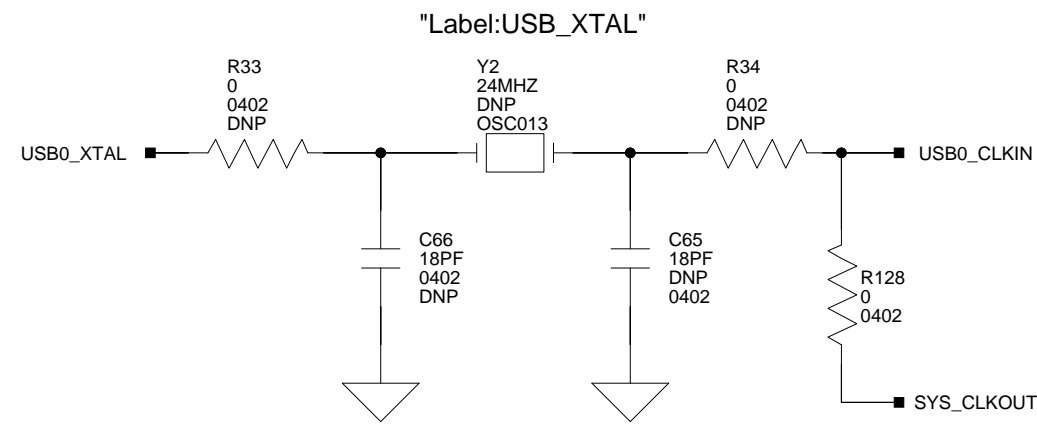

# "Label: PB1"

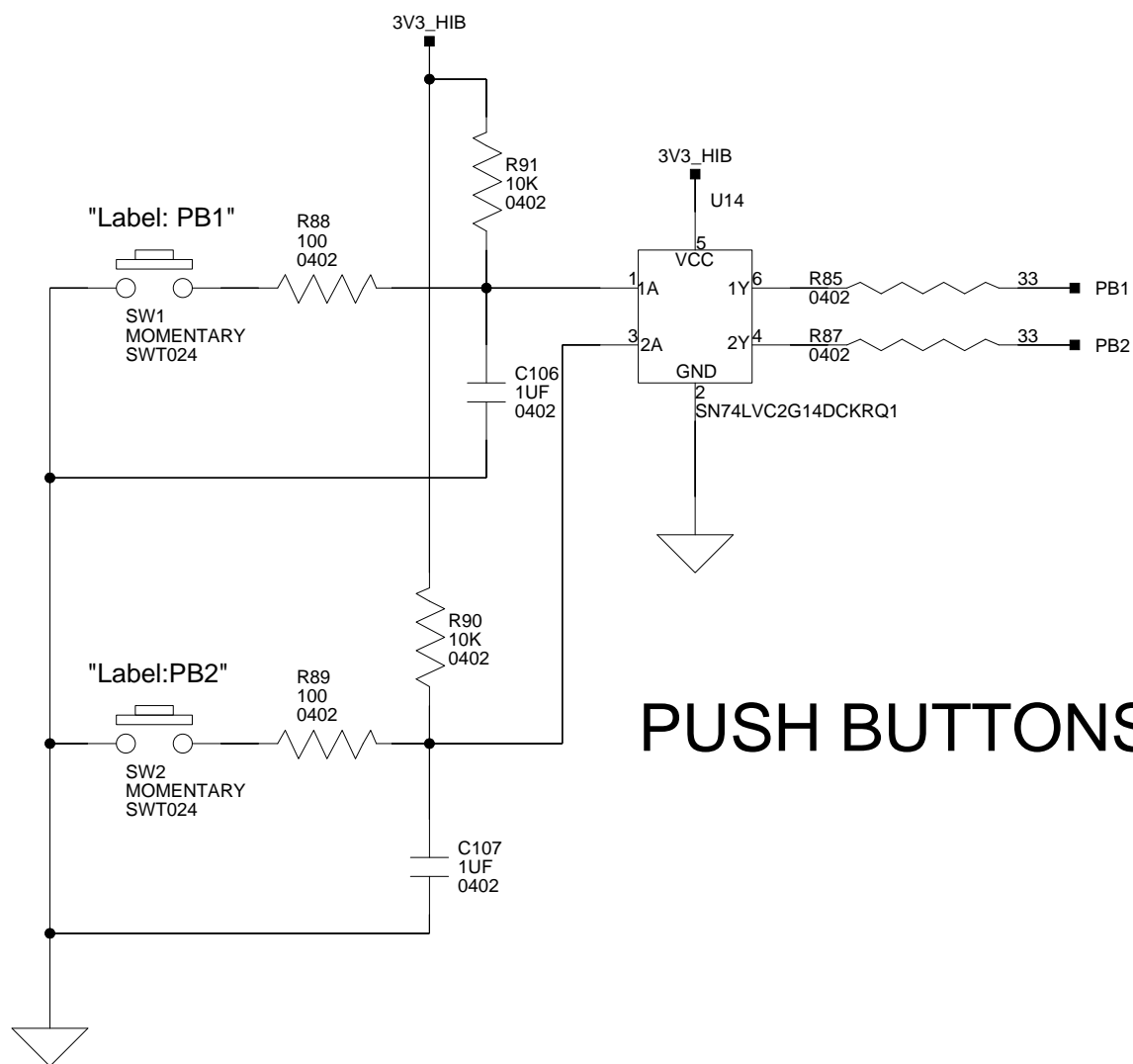

# PUSH BUTTONS

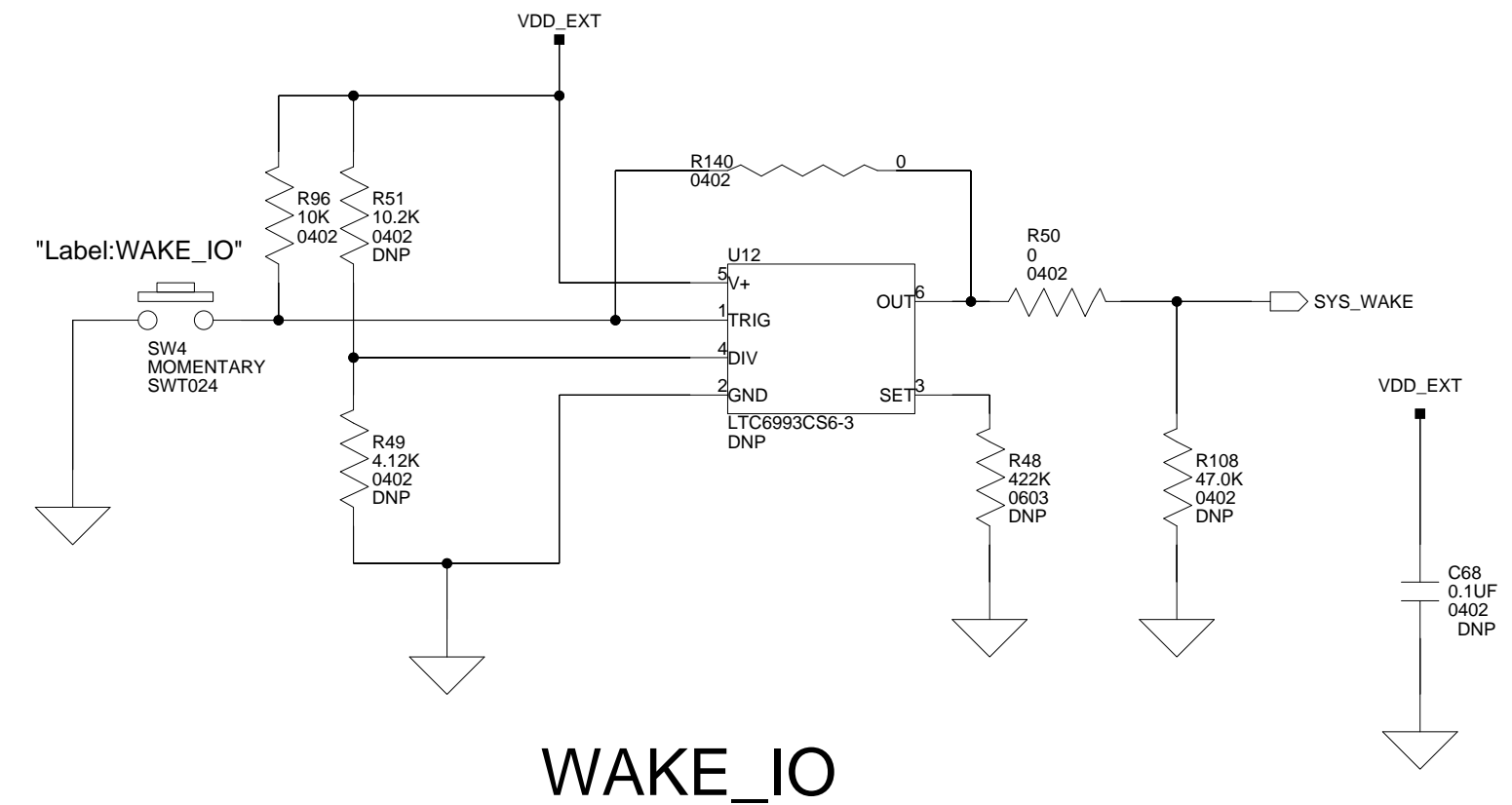

# WAKE\_IO

# "Label: RESET "

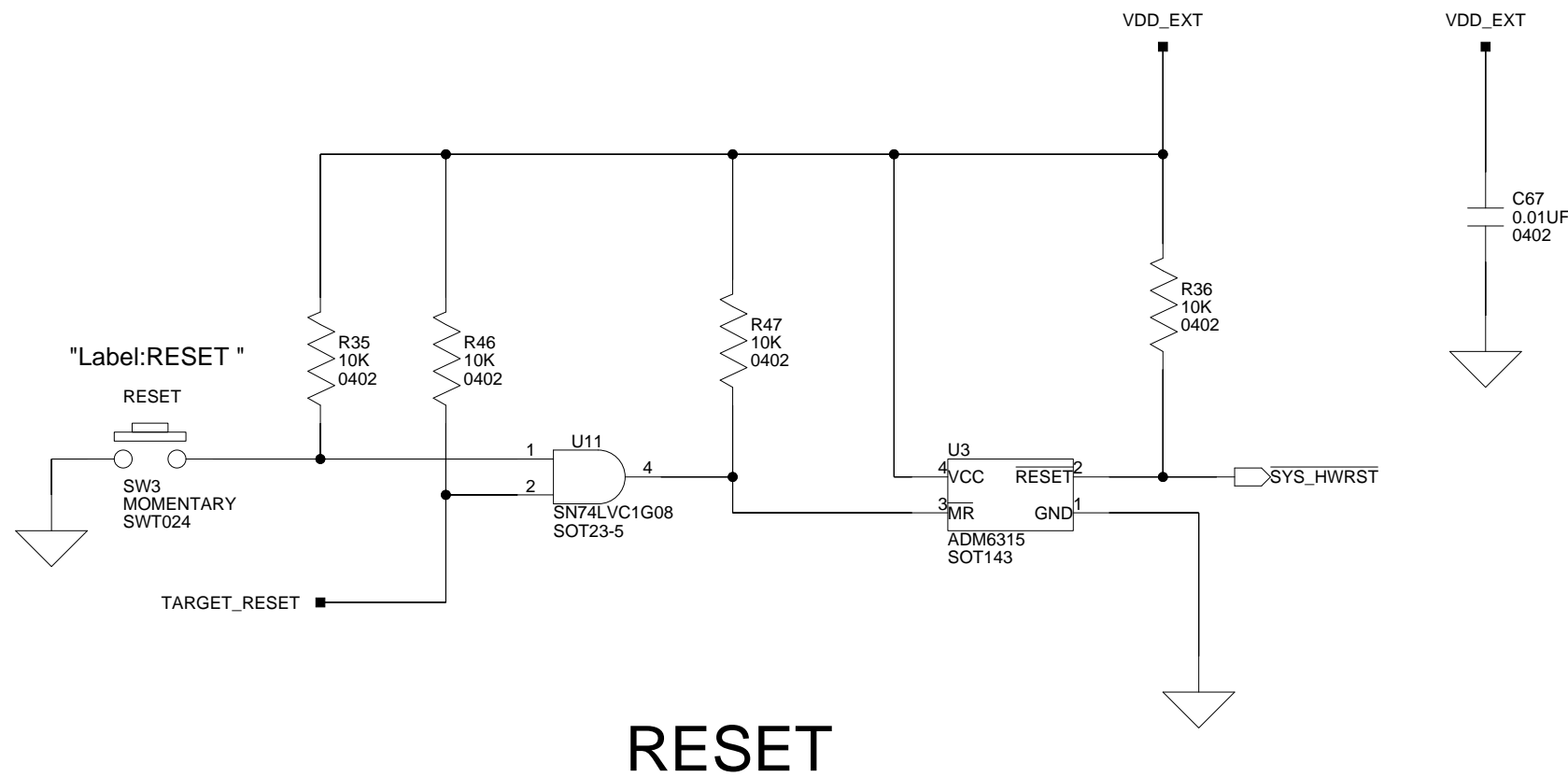

# RESET



**ANALOG  
DEVICES**

20 Cotton Road  
Nashua, NH 03063  
PH: 1-800-ANALOGD

Title **BLIP2**  
RESET,BOOT CNFG,XTAL,PUSH BOTTON AND WAKE IO

Size C	Board No. A0573-2013	Rev 1.0
Date 02/05/15	Sheet 5	of 10

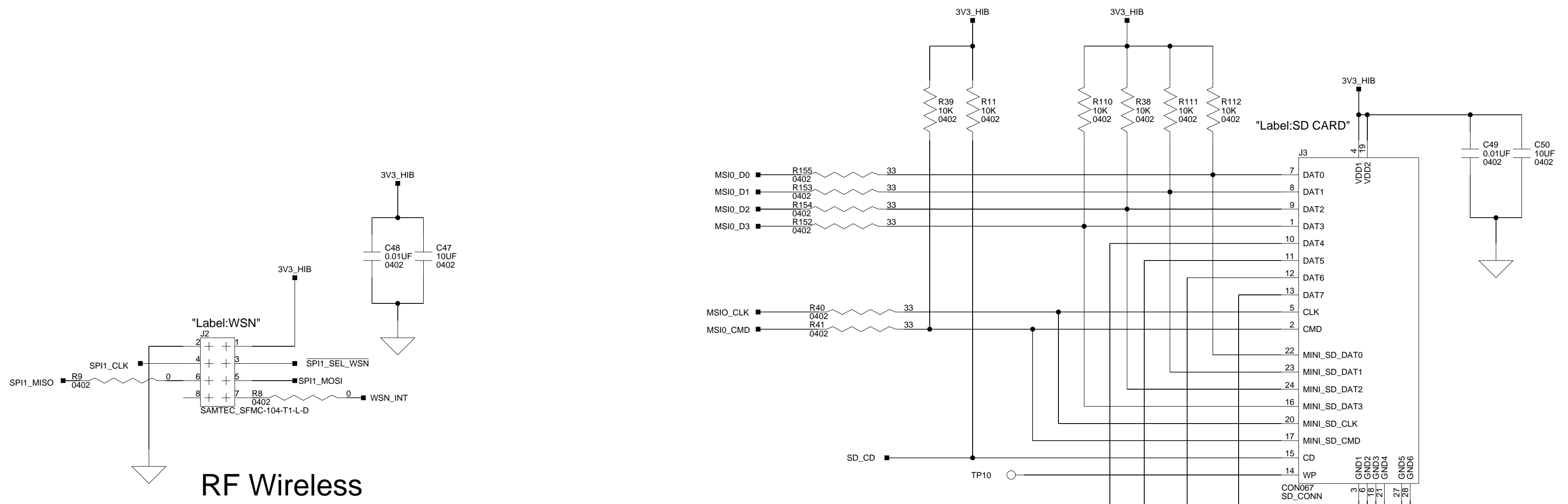

RF Wireless

SD CARD

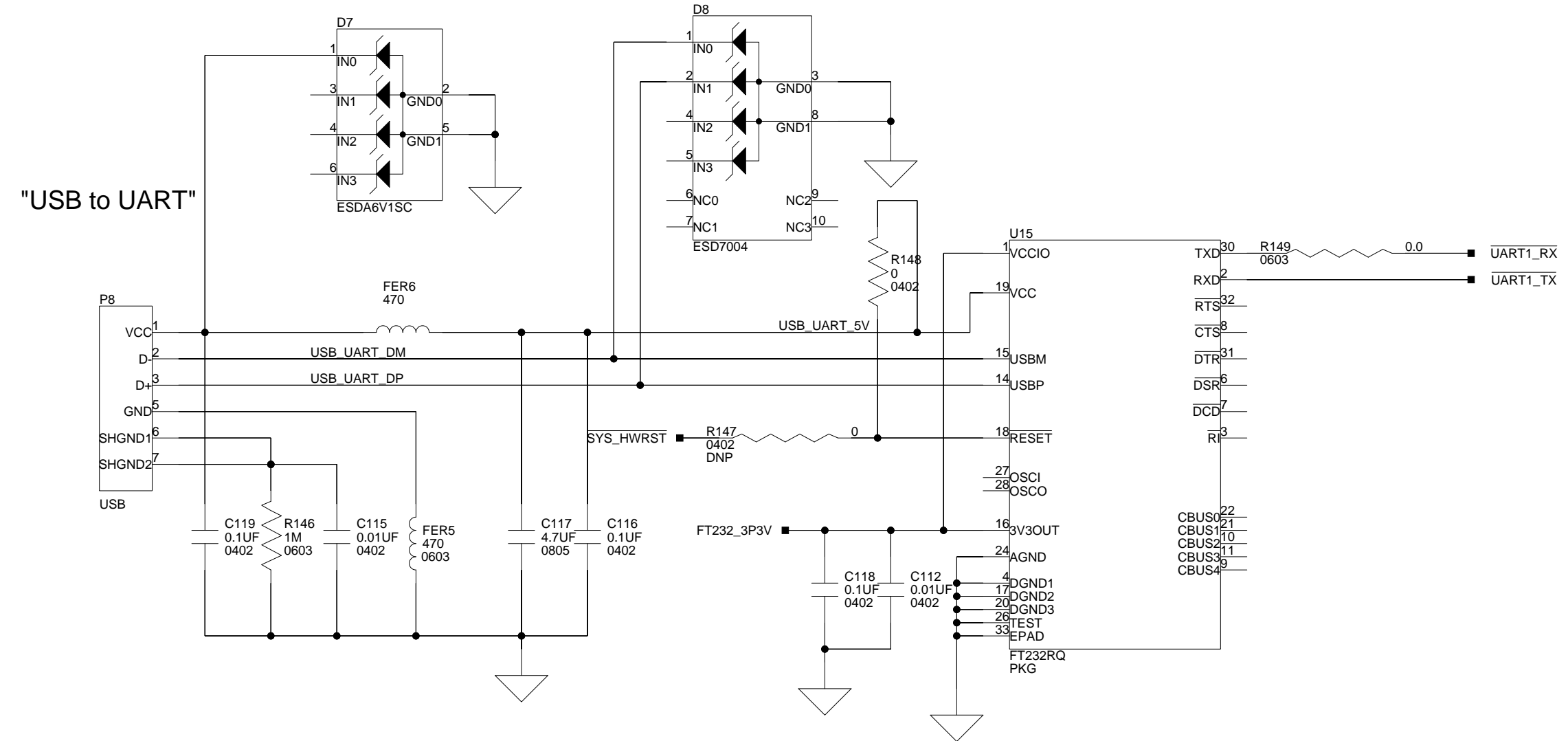

"USB to UART"

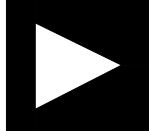
 <b>ANALOG DEVICES</b>		20 Cotton Road Nashua, NH 03063 PH: 1-800-ANALOGD	
		<b>Title</b> BLIP2 USB TO UART, WSN, SD CARD INTERFACE	
<b>Size C</b>	<b>Board No.</b> A0573-2013	<b>Rev</b> 1.0	
<b>Date</b> 02/05/15	<b>Sheet</b> 6 of 10		

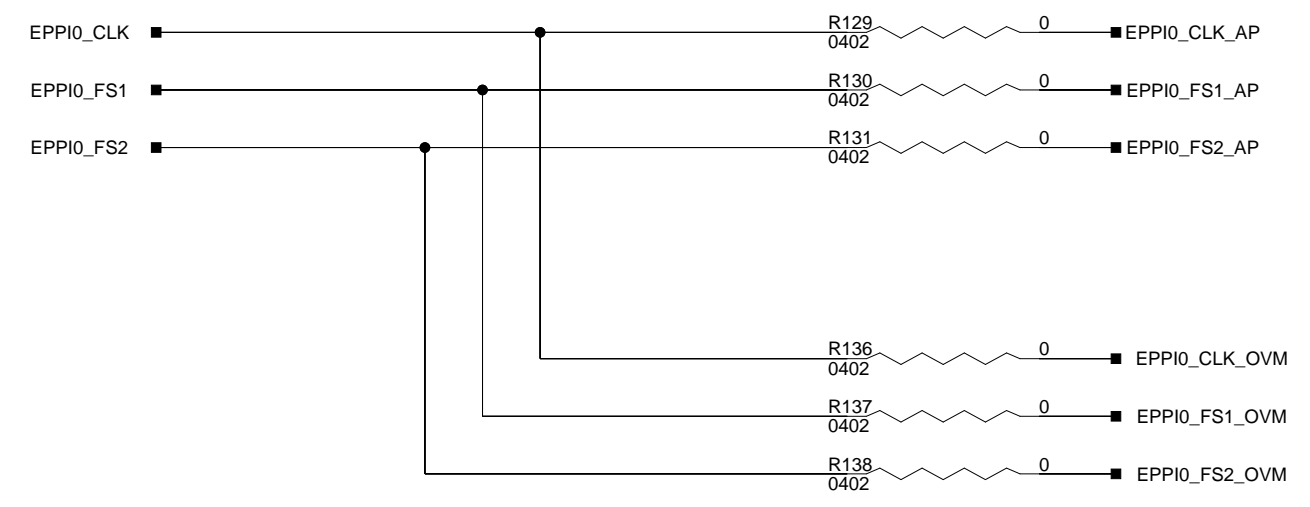
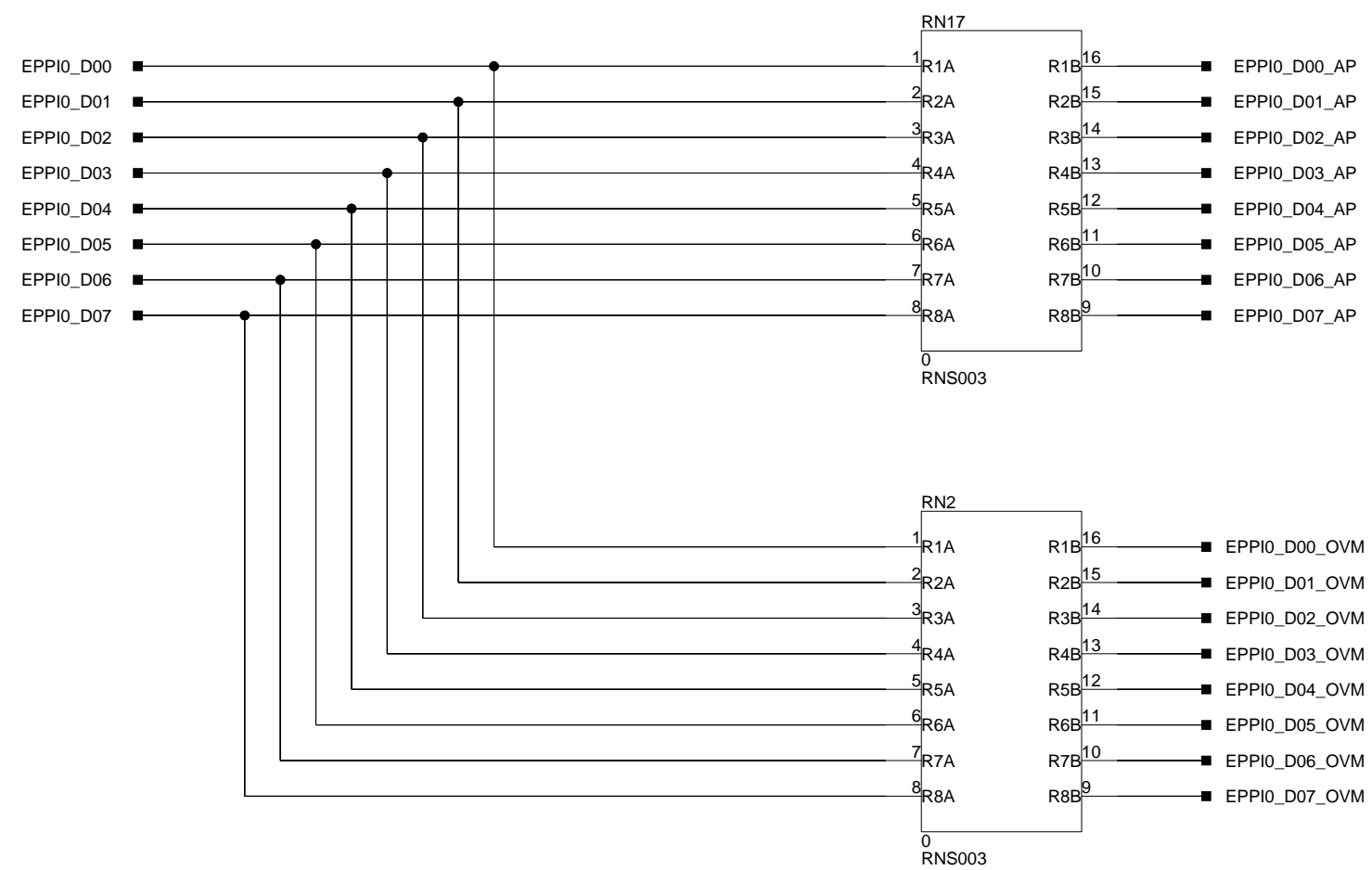

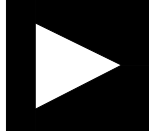
 <b>ANALOG DEVICES</b>		20 Cotton Road Nashua, NH 03063 PH: 1-800-ANALOGD
<b>Title</b> BLIP2 RESISTOR PACKS		
<b>Size</b> C	<b>Board No.</b> A0573-2013	<b>Rev</b> 1.0
<b>Date</b> 02/05/15	<b>Sheet</b> 7 <b>of</b> 10	

A

B

C

D

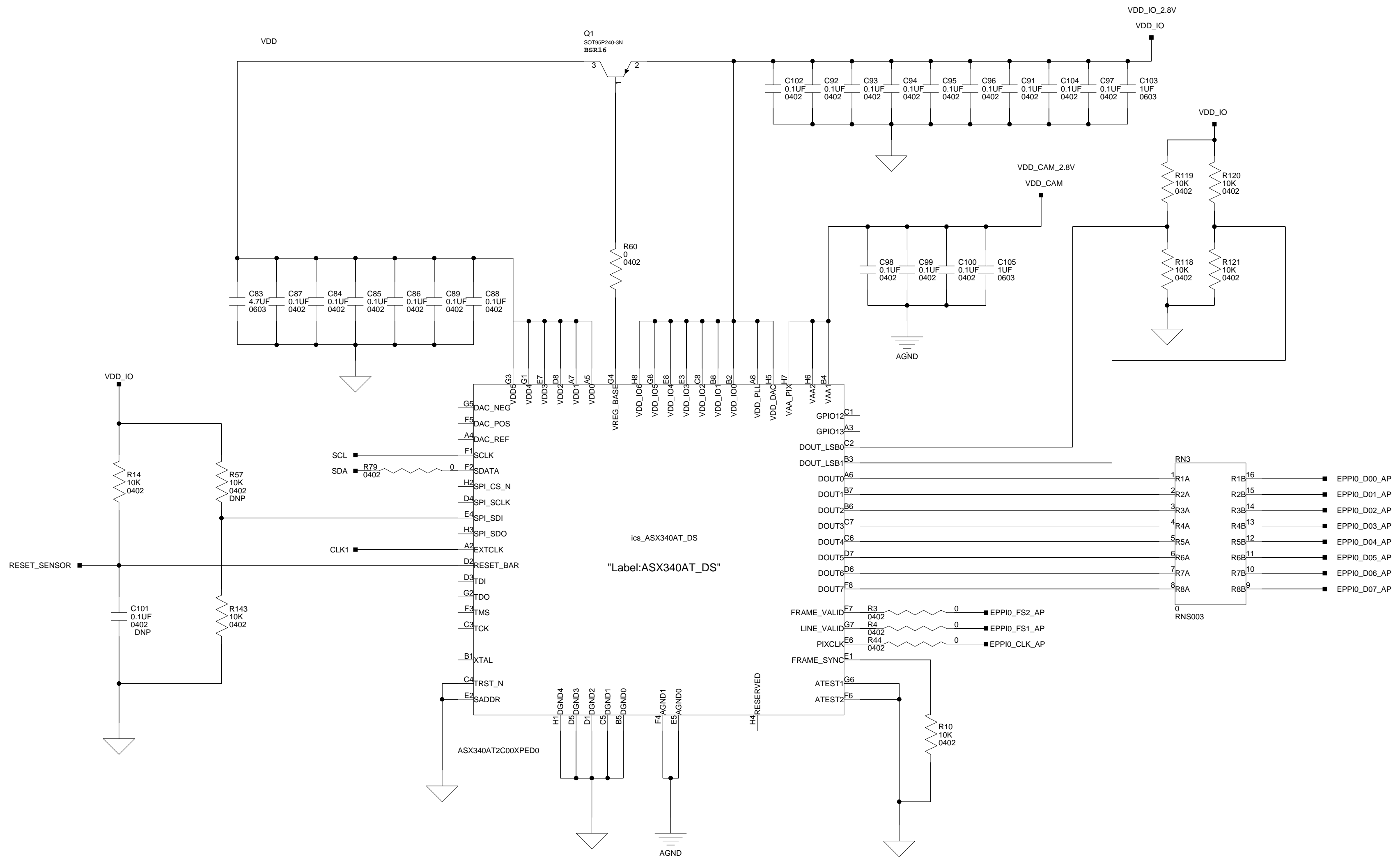

### ASX340AT\_DS-CMOS SENSOR

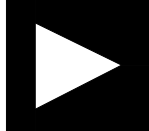
 <b>ANALOG DEVICES</b>		20 Cotton Road Nashua, NH 03063 PH: 1-800-ANALOGD
<b>Title</b> BLIP2 IMAGE SENSOR		
<b>Size C</b>	<b>Board No.</b> A0573-2013	<b>Rev</b> 1.0
<b>Date</b> 02/05/15	<b>Sheet</b> 8 <b>of</b> 10	



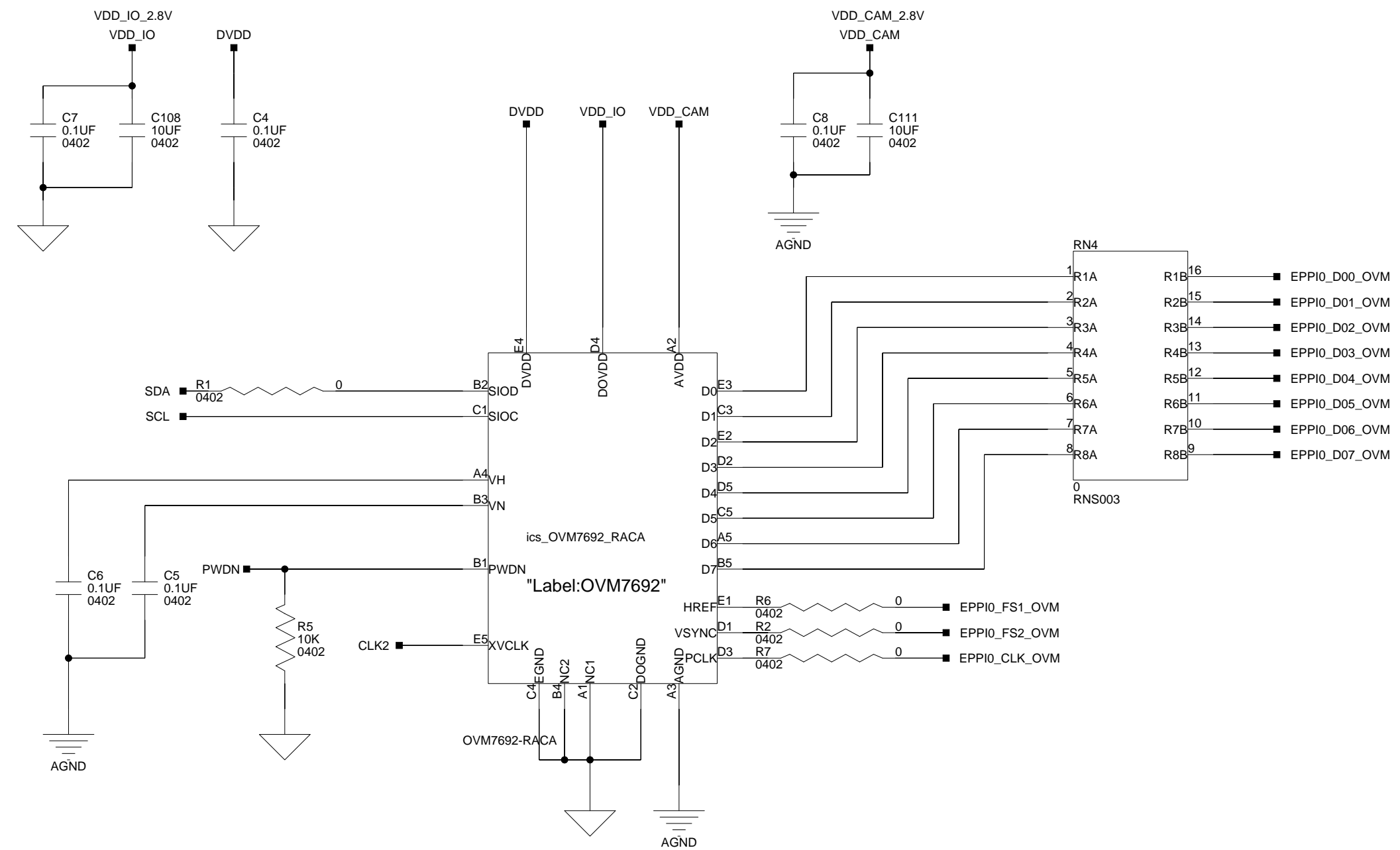

### OVM7692-CMOS SENSOR

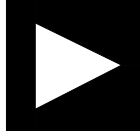
 <b>ANALOG DEVICES</b>		20 Cotton Road Nashua, NH 03063 PH: 1-800-ANALOGD	
		<b>Title</b> BLIP2 IMAGE SENSOR	
<b>Size C</b>	<b>Board No.</b> A0573-2013	<b>Rev</b> 1.0	
<b>Date</b> 02/05/15	<b>Sheet</b> 9		<b>of</b> 10

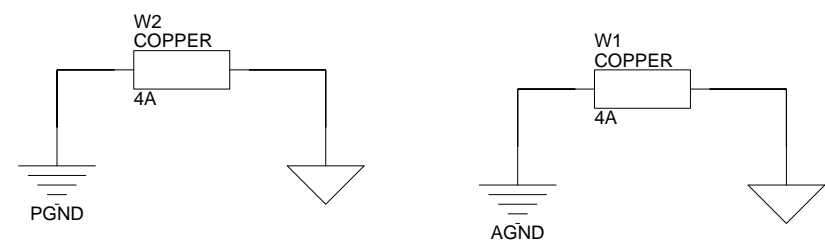
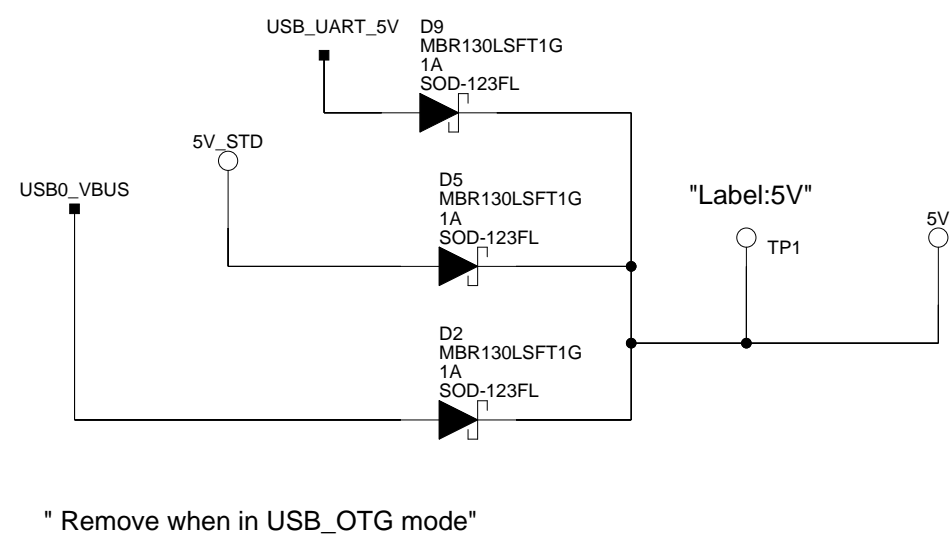
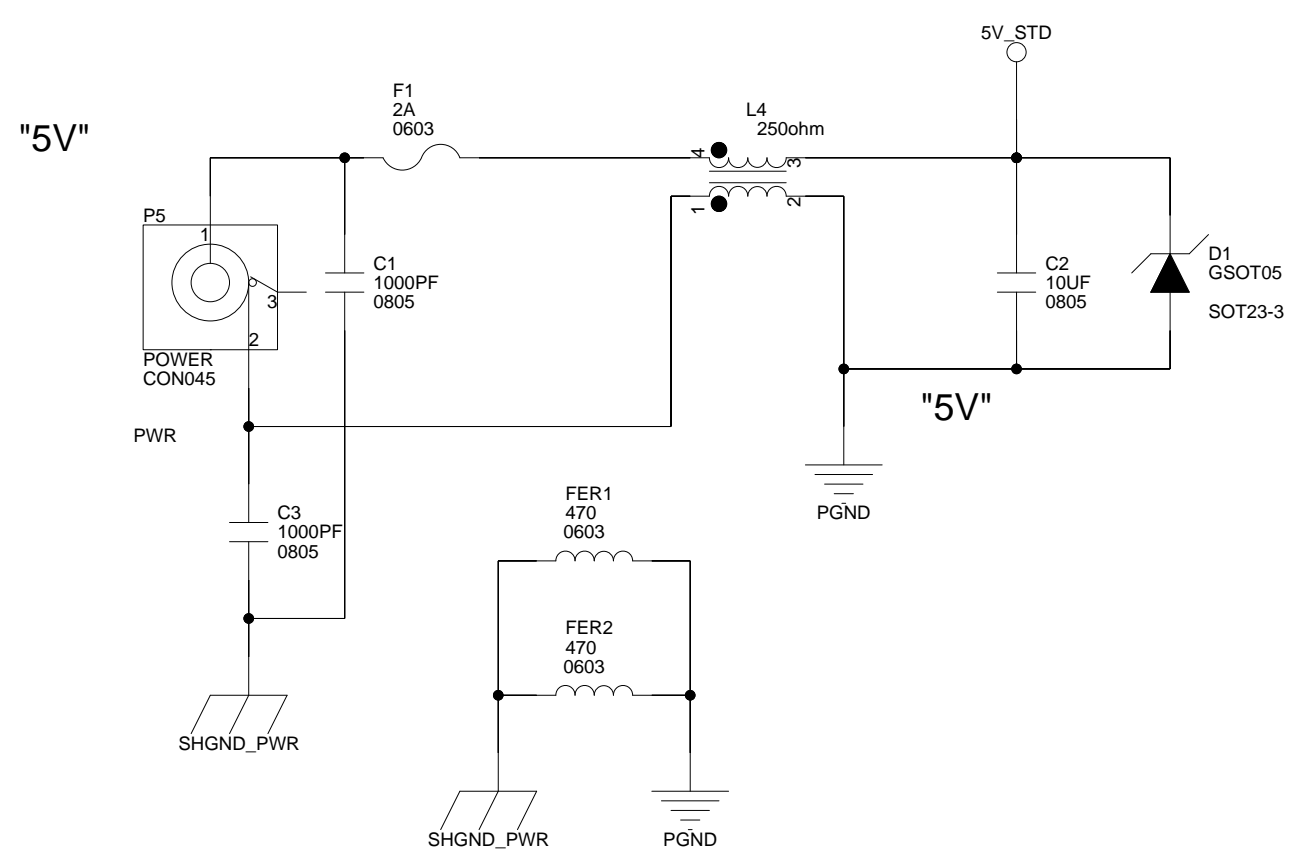
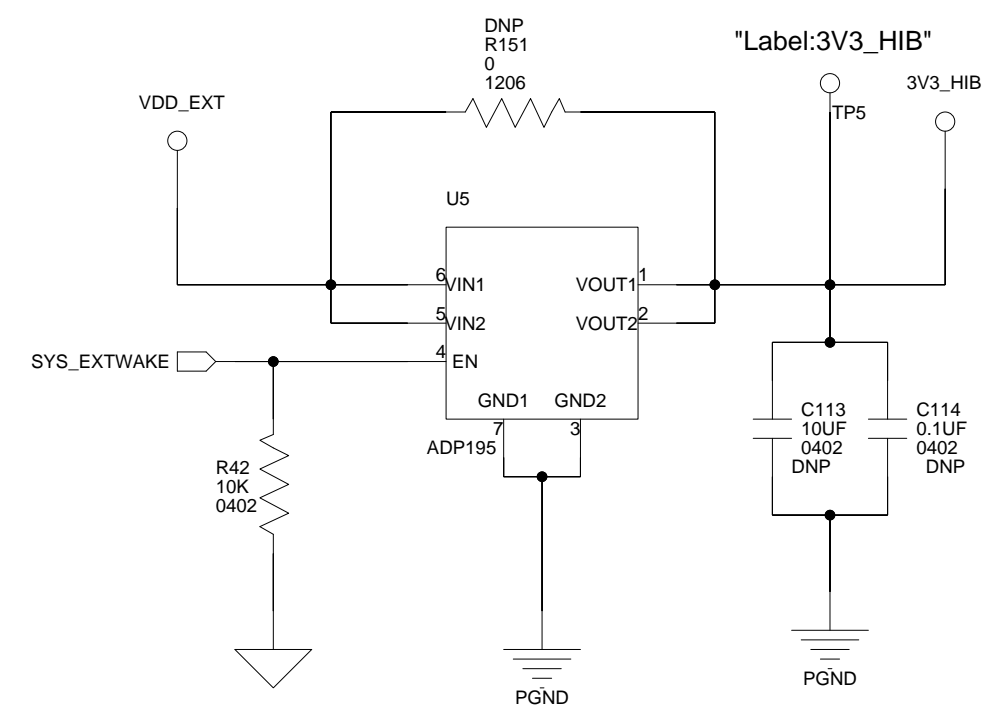
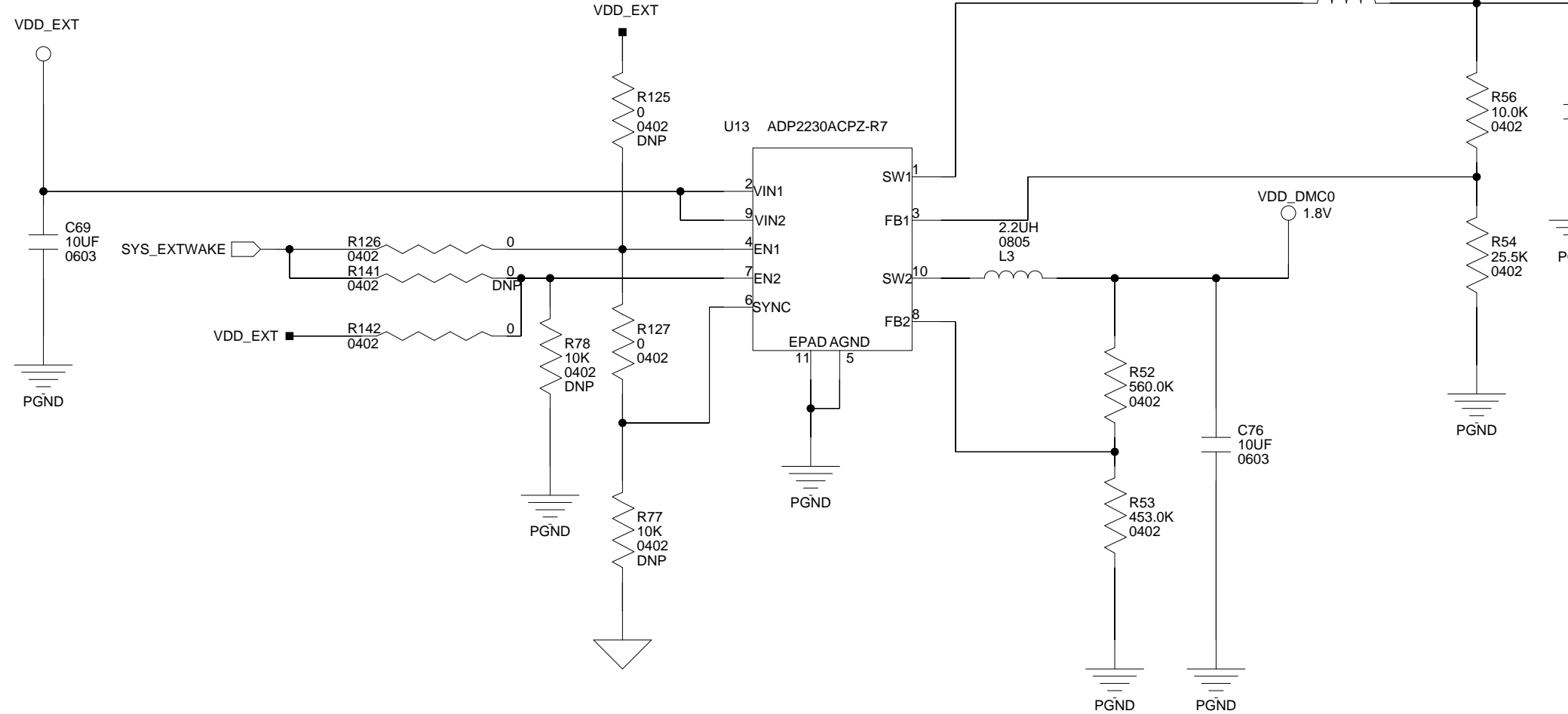
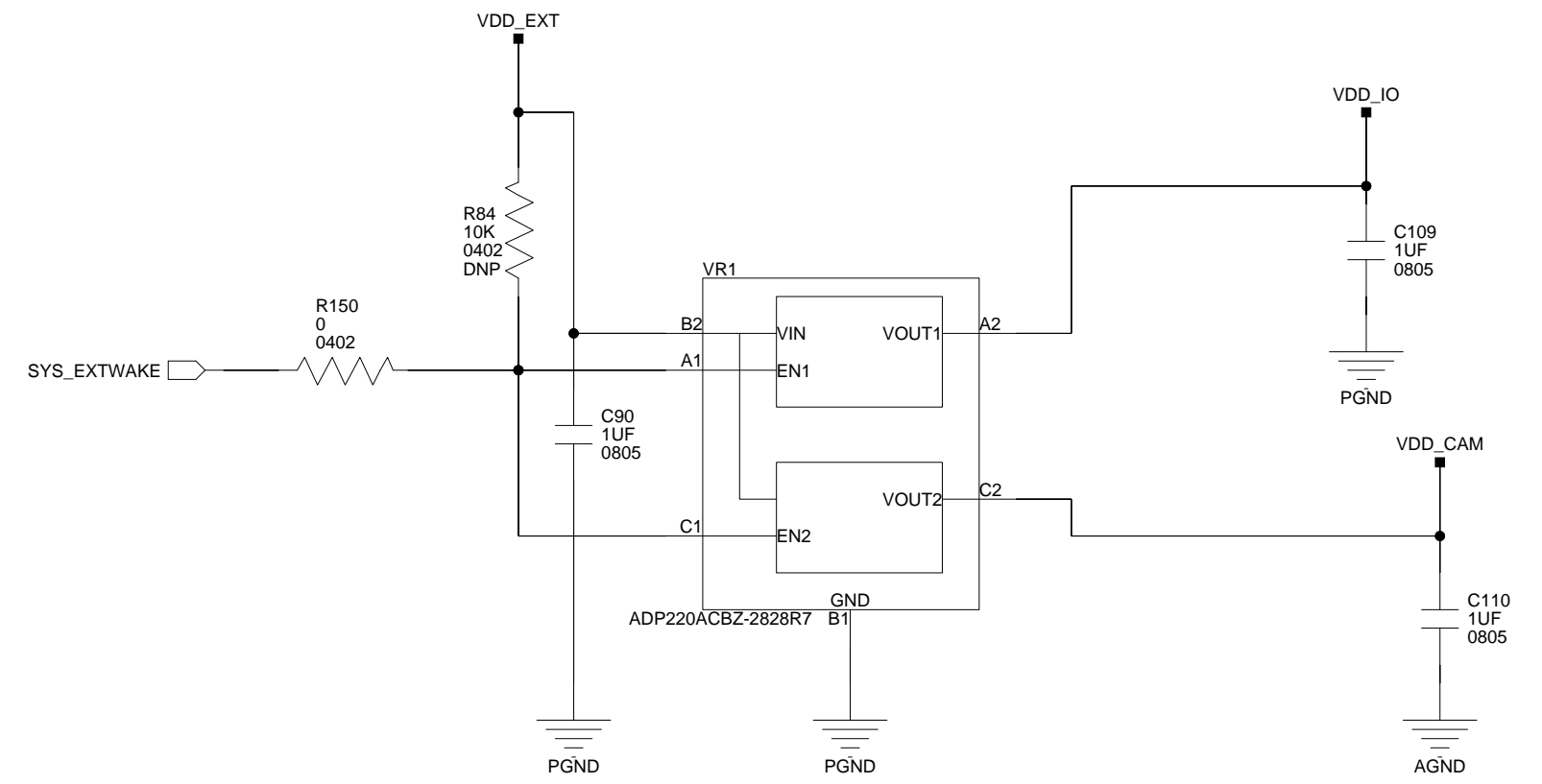
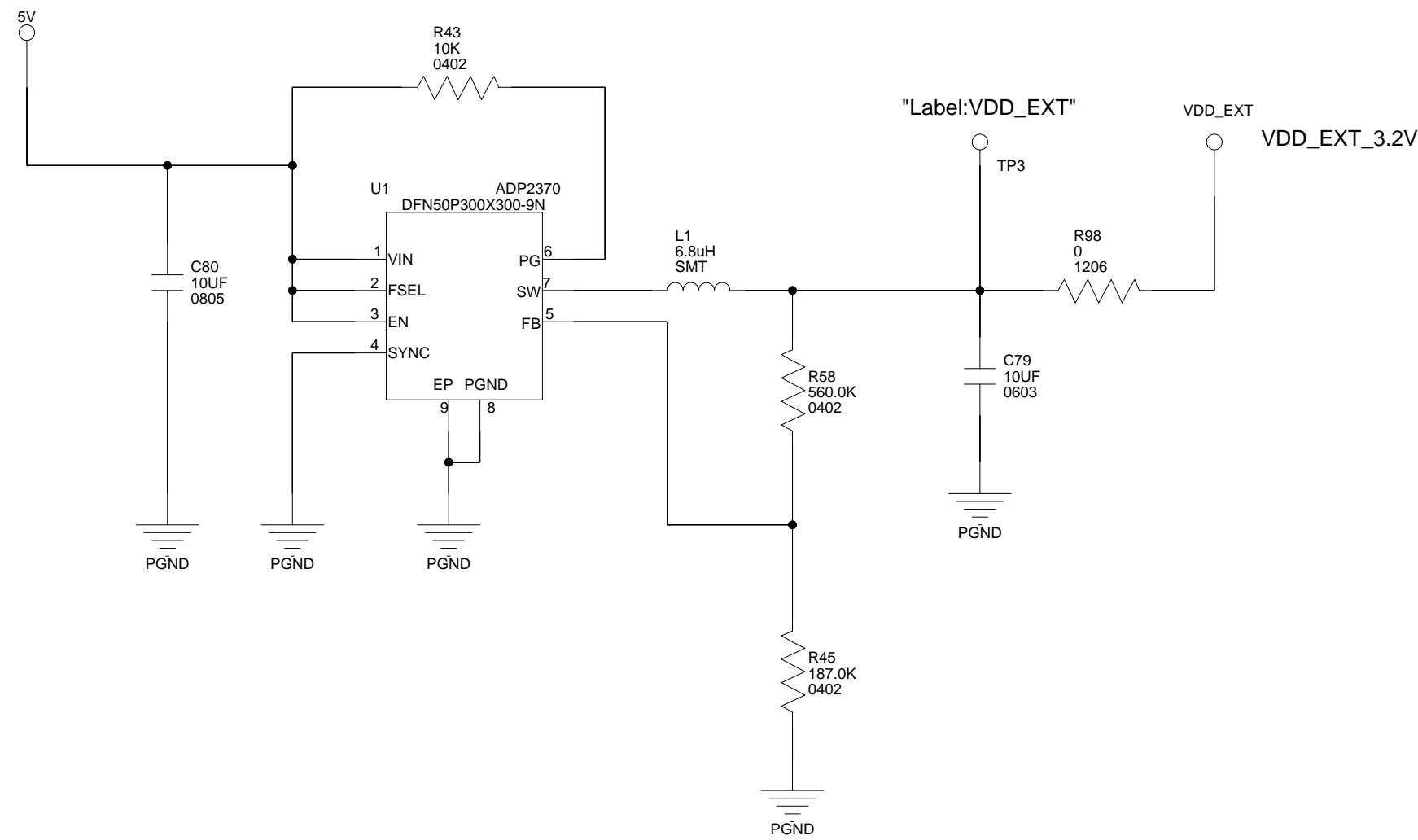

		20 Cotton Road Nashua, NH 03063 PH: 1-800-ANALOGD	
		<b>Title</b> <b>BLIP2 POWER</b>	
<b>Size C</b>	<b>Board No.</b> A0573-2013	<b>Rev</b> 1.0	
<b>Date</b> 02/05/15	<b>Sheet</b> 10 <b>of</b> 10		

# I INDEX

## A

ADSP-BF707 processor, [x](#)  
architecture, of this BLIP2 board, [2-2](#)  
audio interface, [1-9](#)

## B

bill of materials, [A-1](#)  
BLIP2 board installation, [1-3](#)  
BLIP2 board session startup, [1-4](#)  
board schematic (ADZS-BF707-BLIP2), [B-1](#)

## C

configuration, of this BLIP2 board, [1-2](#)  
connectors, [2-8](#)  
    diagram of locations, [2-8](#), [2-9](#)  
    J2 (RF wireless), [2-11](#)  
    J3 (SD), [2-11](#)  
    P3 (JTAG/SWD/SWO), [2-10](#)  
    P4 (USB), [2-10](#)  
    P5 (power), [2-11](#)  
    P8 (USB to UART), [2-10](#)  
contents, of this BLIP2 board package, [1-2](#)

## D

DDR3 memory, [1-7](#)  
debug interface, [1-9](#)  
default configuration, of this BLIP2 board, [1-2](#)

## E

EngineerZone, [xvi](#)  
evaluation license, [1-6](#)  
example programs, [1-10](#)

## G

GPIO push buttons (SW1 and SW2), [2-5](#)  
GPIO Status LED (LED1), [2-7](#)

## I

installation, of this BLIP2 board, [1-3](#)  
interface  
    debug, [1-9](#)  
    SD, [1-9](#)  
    UART, [1-8](#)

## J

JTAG/SWD/SWO connector (P3), [2-10](#)

## L

LEDs, [2-6](#)  
    diagram of locations, [2-6](#)  
    LED1 (GPIO status), [2-7](#)  
    LED4 (SYS\_FAULT), [2-7](#)  
license restrictions, [1-6](#)

## N

notation conventions, [xvi](#)

# Index

## P

- package contents, [1-2](#)
- POST (power-on-self-test), [1-9](#)
- power
  - architecture, [1-10](#)
- power architecture, [1-10](#)
- power connector (P5), [2-11](#)
- power-on-self test (POST), [1-9](#)
- product overview, [x](#)
- push buttons, [2-4](#)
  - GPIO (SW1 and SW2), [2-5](#)
  - reset (SW3), [2-5](#)
  - WAKE IO (SW4), [2-5](#)
- push buttons, diagram of locations, [2-4](#)

## R

- reference design information, [1-11](#)
- reset push button (SW3), [2-5](#)
- RF wireless connector (J2), [2-11](#)

## S

- schematic, of ADZS-BF707-BLIP2 board, [B-1](#)
- SD connector (J3), [2-11](#)
- SD interface, [1-9](#)
- SPI flash, [1-8](#)
- supported tools, [xv](#)
- SW1 and SW2 GPIO push buttons, [2-5](#)
- SW3 reset push button, [2-5](#)
- SW4 WAKE IO push button, [2-5](#)
- SYS\_FAULT LED (LED4), [2-7](#)
- system architecture, of this BLIP2 board, [2-2](#)

## T

- technical support, [xiv](#)

## U

- UART interface, [1-8](#)
- USB connector (P4), [2-10](#)
- USB interface, [1-8](#)
- USB to UART connector (P8), [2-10](#)

## W

- WAKE IO push button (SW4), [2-5](#)