

User Manual

EBPC-5250

Embedded Industrial Computer
Chassis for 5.25" Biscuit SBCs

Trusted ePlatform Services



Copyright

The documentation and the software included with this product are copyrighted 2008 by Advantech Co., Ltd. All rights are reserved. Advantech Co., Ltd. reserves the right to make improvements in the products described in this manual at any time without notice. No part of this manual may be reproduced, copied, translated or transmitted in any form or by any means without the prior written permission of Advantech Co., Ltd. Information provided in this manual is intended to be accurate and reliable. However, Advantech Co., Ltd. assumes no responsibility for its use, nor for any infringements of the rights of third parties, which may result from its use.

Acknowledgements

EBPC-5250, PCM-9581, PCM-9582, PCM-9584, PCM-9586 and PCM-9587 are trademarks of Advantech Co., Ltd. All other product names or trademarks are properties of their respective owners.

On-line Technical Support

For technical support and service, please visit our support website at:
<http://www.advantech.com/support>

Safety Instructions

1. Read these safety instructions carefully.
2. Keep this user manual for later reference.
3. Disconnect this equipment from AC outlet before cleaning. Do not use liquid or spray detergents for cleaning.
4. For pluggable equipment, the power outlet should be installed near the equipment and shall be easily accessible.
5. Keep this equipment away from humidity.
6. Put this equipment on a reliable surface during installation. Dropping it or letting it fall could cause damage.
7. Do not leave this equipment in an environment where the storage temperature is under 0°C (32°F) or above 40°C (104°F), it may damage the equipment.
8. The openings on the enclosure are for air convection thereby protecting the equipment from overheating. **DO NOT COVER THE OPENINGS.**
9. Make sure the voltage of the power source is correct before connecting the equipment to the power outlet.
10. Place the power cord such a way that people can not step on it. Do not place anything over the power cord. The voltage and current rating of the cord should be greater than the voltage and current rating marked on the product.
11. All cautions and warnings on the equipment should be noted.
12. If the equipment is not used for long time, disconnect it from the power source to avoid being damaged by transient over-voltage.
13. Never pour any liquid into ventilation openings. This could cause fire or electrical shock.
14. Never open the equipment. For safety reasons, the equipment should be opened only by qualified service personnel.
15. If any of the following situations arises, get the equipment checked by service personnel:
 - a. The power cord or plug is damaged.
 - b. Liquid has penetrated into the equipment.
 - c. The equipment has been exposed to moisture.
 - d. The equipment does not work well or you cannot get it to work according to user manual.
 - e. The equipment has been dropped and damaged.
 - f. The equipment has obvious signs of breakage.
16. The computer is provided with CD drives that comply with appropriate safety standards including IEC 60825.

KLASS 1 LASER PRODUKT CLASS 1 LASER PRODUCT
--

17. This device complies with Part 15 of the FCC rules. Operation is subject to the following two conditions:
 - 1). this device may not cause harmful interference, and
 - 2). this device must accept any interference received, including interference that may cause undesired operation.

Caution! *The computer is provided with a battery-powered real-time clock circuit. There is a danger of explosion if battery is incorrectly replaced. Replace only with same or equivalent type recommended by the manufacturer. Discard used batteries according to the manufacturer's instructions.*



Caution! *Always completely disconnect the power cord from your chassis whenever you work with the hardware. Do not make connections while the power is on. Sensitive electronic components can be damaged by sudden power surges.*



Caution! *Always ground yourself to remove any static charge before touching the motherboard, backplane, or add-on cards. Modern electronic devices are very sensitive to static electric charges. As a safety precaution, use a grounding wrist strap at all times. Place all electronic components on a static-dissipative surface or in a static-shielded bag when they are not in the chassis.*



Caution! *Any unverified component could cause unexpected damage. To ensure the correct installation, please always use the components (ex. screws) provided with the accessory box.*



Safety Precaution - Static Electricity

Follow these simple precautions to protect yourself from harm and the products from damage.

1. To avoid electrical shock, always disconnect the power from your PC chassis before you work on it. Don't touch any components on the CPU card or other cards while the PC is on.
2. Disconnect power before making any configuration changes. The sudden power surge as you connect a jumper or install a card may damage sensitive electronic components.

A Message to the Customer

Advantech customer service

Each and every Advantech product is built to the most exacting specifications to ensure reliable performance in the harsh and demanding conditions typical of industrial environments. Whether your new Advantech equipment is destined for the laboratory or the factory floor, you can be assured that your product will provide the reliability and ease of operation for which the name Advantech has come to be known. Your satisfaction is our primary concern. Here is a guide to Advantech's customer services.

To ensure you get the full benefit of our services, please follow the instructions below carefully.

Technical support

We want you to get the best performance possible from your products. If you run into technical difficulties, we are here to help. For the most frequently asked questions, you can easily find answers in your product documentation. These answers are normally a lot more detailed than the ones we can give over the phone.

Please consult this manual first. If you still cannot find the answer, gather all the information or questions that apply to your problem, and with the product close at hand, call your dealer. Our dealers are well trained and ready to give you the support you need to get the most from your Advantech products. In fact, most problems reported are minor and can be easily solved over the phone.

In addition, free technical support is available from Advantech engineers every business day. We are always ready to give advice about application requirements or specific information on the installation and operation of any of our products.

Product Warranty (2 years)

Advantech warrants to you, the original purchaser, that each of its products will be free from defects in materials and workmanship for two years from the date of purchase.

This warranty does not apply to any products which have been repaired or altered by persons other than repair personnel authorized by Advantech, or which have been subject to misuse, abuse, accident or improper installation. Advantech assumes no liability under the terms of this warranty as a consequence of such events.

Because of Advantech's high quality-control standards and rigorous testing, most of our customers never need to use our repair service. If an Advantech product is defective, it will be repaired or replaced at no charge during the warranty period. For out-of-warranty repairs, you will be billed according to the cost of replacement materials, service time and freight. Please consult your dealer for more details.

If you think you have a defective product, follow these steps:

1. Collect all the information about the problem encountered. (For example, CPU speed, Advantech products used, other hardware and software used, etc.) Note anything abnormal and list any onscreen messages you get when the problem occurs.
2. Call your dealer and describe the problem. Please have your manual, product, and any helpful information readily available.
3. If your product is diagnosed as defective, obtain an RMA (return merchandise authorization) number from your dealer. This allows us to process your return more quickly.
4. Carefully pack the defective product, a fully-completed Repair and Replacement Order Card and a photocopy proof of purchase date (such as your sales receipt) in a shippable container. A product returned without proof of the purchase date is not eligible for warranty service.
5. Write the RMA number visibly on the outside of the package and ship it prepaid to your dealer.

Initial Inspection

When you open the carton, please make sure that the following materials have been shipped:

- EBPC-5250 Chassis
- User Manual
- Warranty Card
- Accessory box with a package of screws (for fastening the SBC, 3.5" disk drive, slim-type optical disk drive, mounting brackets, riser card), 4 pcs of rubber pads, a pair of mounting brackets, a label (for the pre-punched I/O ports), and a pack of I/O cables.

If any of these items are missing or damaged, contact your distributor or sales representative immediately. We have carefully inspected the product mechanically and electrically before shipment. It should be free of marks and scratches and in perfect working order upon receipt. As you unpack the product, check it for signs of shipping damage. (For example, damaged box, scratches, dents, etc.) If it is damaged or it fails to meet the specifications, notify our service department or your local sales representative immediately. Also, please notify the carrier. Retain the shipping carton and packing material for inspection by the carrier. After inspection, we will make arrangements to repair or replace the unit.

Contents

Chapter 1	General Information	1
1.1	Introduction	2
1.2	Specifications	2
1.3	Power Supply	3
	Table 1.1: Power Supply	3
1.4	Environmental Specifications	3
1.5	Dimensions of the EBPC-5250	3
	Figure 1.1 Dimension diagram of the EBPC-5250.....	3
Chapter 2	System Setup	5
2.1	Removing the Top Cover	6
	Figure 2.1 Removing the top cover.....	6
2.2	Installing the CompactFlash or Mini PCI Module	7
	Figure 2.2 Removing the bottom cover for maintenance of the CompactFlash or mini PCI module.....	7
2.3	Installing the 5.25" Biscuit SBC.....	7
	Figure 2.3 Installing an SBC.....	8
2.4	Installing a PCI Card or PC/104 Module or Riser Card	8
	Figure 2.4 Installing a riser card	9
	Figure 2.5 Remove the round plastic cap to fasten/loose the screw to the add-on cards.....	9
2.5	Installing the Disk Drives.....	10
2.5.1	Installing a 3.5" Hard Disk Drive	10
	Figure 2.6 Installing a 3.5" HDD	10
2.5.2	Installing a Slim-type Optical Disk Drive	11
	Figure 2.7 Install a slim-type optical disk drive into the chassis	11
	Figure 2.8 Small converter for slim-type optical disk drive	11
2.6	Attaching the Mounting Brackets	12
	Figure 2.9 Attaching the mounting brackets	12
Chapter 3	I/O Board, Optional Display Module Kit & Cable Connections	13
3.1	I/O Board Layout.....	14
	Figure 3.1 Front I/O board layout.....	14
3.2	Cable Connections between the PCM-9581/9586 and I/O Board.....	15
	Table 3.1: Cable Connections between PCM-9581/9586 and I/O Board	15
3.3	Cable Connections between the PCM-9582/9587 and I/O Board.....	16
	Table 3.2: Cable Connections between PCM-9582/9587 and I/O Board	16
3.4	Cable Connections between the PCM-9584 and I/O Board.....	17
	Table 3.3: Cable Connections between PCM-9584 and I/O Board	17
3.5	Required Cable Kit Connections between the PCM-9581FG/9582FG/9584 and I/O Board.....	18
	Table 3.4: Optional Cable Kit Connections between PCM- 9581FG/9582FG/9584 and I/O Board	18
3.6	Optional Display Module Layout	19
	Figure 3.2 Display module layout	19
3.7	Cable Connections Between the SBC and the Display Module.....	19

Table 3.5: Cable Connections Between the SBC and the Display Module.....	19
--	----

Chapter 4	Operation	21
4.1	The Front Plate	22
	Figure 4.1 Front plate	22
4.2	The Rear Plate.....	22
	Figure 4.2 Rear plate.....	22
4.3	Replacing the Cooling Fan.....	23
	Figure 4.3 Replacing the system fan.....	23
4.4	Replacing the Power Supply.....	24
	Figure 4.4 Replacing the power supply	24
Appendix A	Exploded Diagram and Parts List....	25
A.1	Exploded Diagram and Parts List	26
	Figure A.1 Exploded diagram	26
	Table A.1: Parts List	26
Appendix B	5.25" Biscuit SBC Options	27
B.1	5.25" Biscuit SBC Options.....	28
	Table B.1: 5.25" Biscuit SBC Options.....	28

Chapter 1

General Information

This chapter provides general information about the EBPC-5250.

Sections include:

- Introduction
- Specifications
- Power Supply
- Environment Specifications
- Dimensions Diagram

1.1 Introduction

The EBPC-5250 is a rugged and compact embedded industrial computer chassis. With an easily customized I/O plate, the unit can be equipped with various 5.25" biscuit SBCs.

Universal, comprehensive and flexible I/O port expansion features

- Built-in universal I/O board that provides external connectivity for all common types of I/O
- Pre-punched I/O ports on the front plate and rear plate for various needs
- Reserved space to expand I/O ports by PCI card, mini PCI, PC/104, PC/104+, or PCI-104 module

Compact and robust construction

- Robust, heavy-duty metal cast construction.
- A specially cushioned design that absorbs vibration of 3.5-inch HDD to ensure maximum reliability

Optimal integration

- Simple and modular design
- Quick installation, easy expansion and maintenance
- Product longevity support to secure investment value

1.2 Specifications

- Construction: Heavy-duty steel
- Disk Drive Capacity: One internal 3.5" disk drive bay and one slim-type optical disk drive bay
- LED Indicators on Front Panel: Single-color LED for Power (green) and HDD activity (red).
- Front I/O Interfaces: Line-in jack, Line-out jack, Mic-in jack, a mini DIN PS/2 mouse connector, a mini DIN PS/2 keyboard connector, four COM ports, a parallel port, a GPIO port, a VGA port, a 10/100 LAN port with LEDs, four USB ports and a GigaLAN port (for PCM-9584). A DVI, four 9-pin D-SUB and four USB openings are also reserved.
- Rear I/O Interfaces: Pre-punched openings for two LVDS ports, one DVI port, one S-Video port and one C-Video port
- Cooling System: one 60 cm x 60 cm (27.5 CFM) cooling fan
- Weight: 2.5 Kg (5.5lb)
- Dimensions (W x H x D): 248 x 118 x 298 mm (9.8" x 4.6" x 11.7")

1.3 Power Supply

The EBPC-5250 accommodates an AC 180W ATX power supply. The detail specifications are listed below:

Table 1.1: Power Supply	
Part Number	1757000277
Wattage	180 W max. (ATX, PFC)
Input rating	100 ~ 240 Vac (Full range)
Output voltage	+5 V @ 12 A, +3.3 V @ 16.8 A, +12 V @ 10 A, -12 V @ 0.8 A, +5 Vsb @ 2 A
Minimum load	+5 V @ 0.3 A, +3.3 V @ 0.3 A, +12 V @ 1.5 A
MTBF	100,000 hours @ 25°C
Safety	UL/TUV/CB/CCC

1.4 Environmental Specifications

- **Temperature:**
(Operating) 0 to 40°C (32 to 104°F)
(Non-Operating) -20 to 60°C (-4 to 140°F)
- **Relative Humidity:** 0% ~ 95% (non-condensing)
- **Vibration During Operation**
1Grms (5 ~ 500 Hz)
- **Shock During Operation**
20G with 11ms duration, half-sine wave

1.5 Dimensions of the EBPC-5250

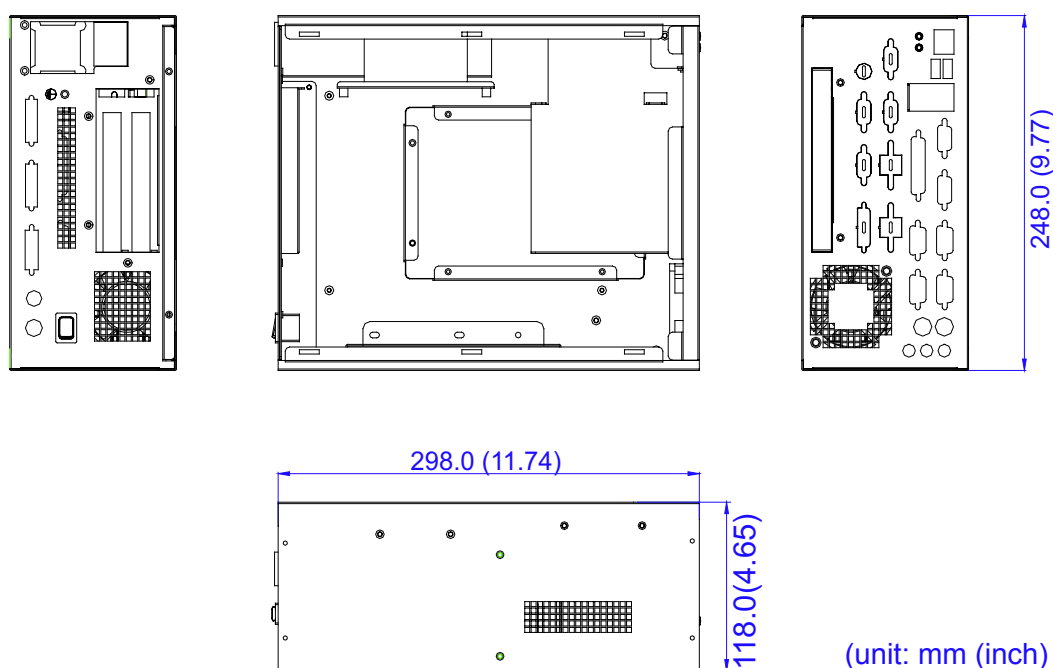

Figure 1.1 Dimension diagram of the EBPC-5250

Chapter 2

System Setup

This chapter introduces the installation process.

Sections include:

- Removing the Top Cover
- Installing the Compact Flash and Mini PCI Module
- Installing the 5.25" SBC
- Installing the Riser Card and Add-on Card
- Installing the 3.5" Disk Drive
- Installing the Slim-type Optical Disk Drive
- Attaching the Mounting Bracket

The following procedures will instruct you how to install a 5.25" SBC, riser card, add-on cards, and disk drive into the chassis.

Note! *Use caution when installing or operating the components with the chassis open. Be sure to turn off the power, unplug the power cord and ground yourself by touching the metal chassis before you handle any components inside the machine.*



2.1 Removing the Top Cover

To remove the top cover, please follow the instructions below:

1. Loosen two screws on the rear of the top cover.
2. Pull the top cover backwards and then lift it up. (see Figure 2.1)

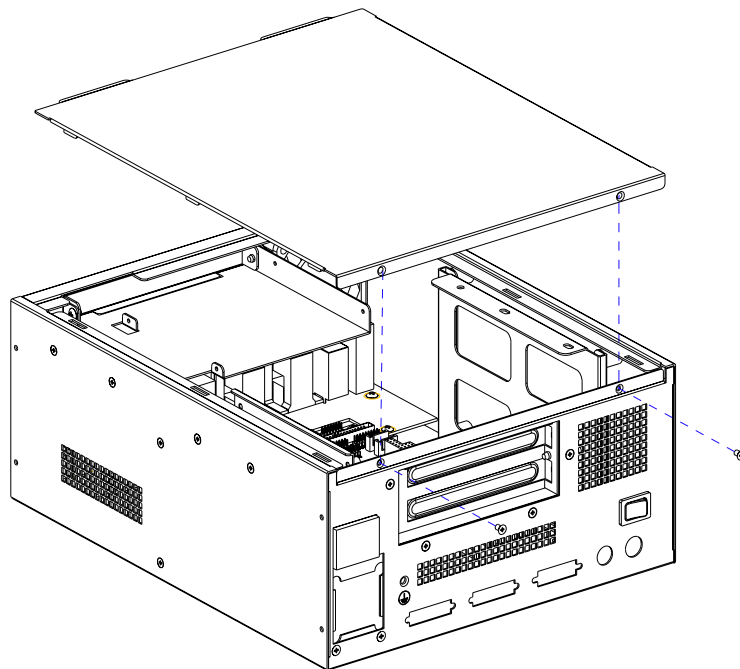

Figure 2.1 Removing the top cover

2.2 Installing the CompactFlash or Mini PCI Module

It's better to insert the CompactFlash or mini PCI module into the socket on the SBC first if it's necessary. After the SBC has been installed into the chassis, users need to open the bottom cover of the chassis by loosening the 6 screws to install or replace the CompactFlash or mini PCI module. (Figure 2.2)

Note! *The CompactFlash is allocated as a Secondary IDE Master.*

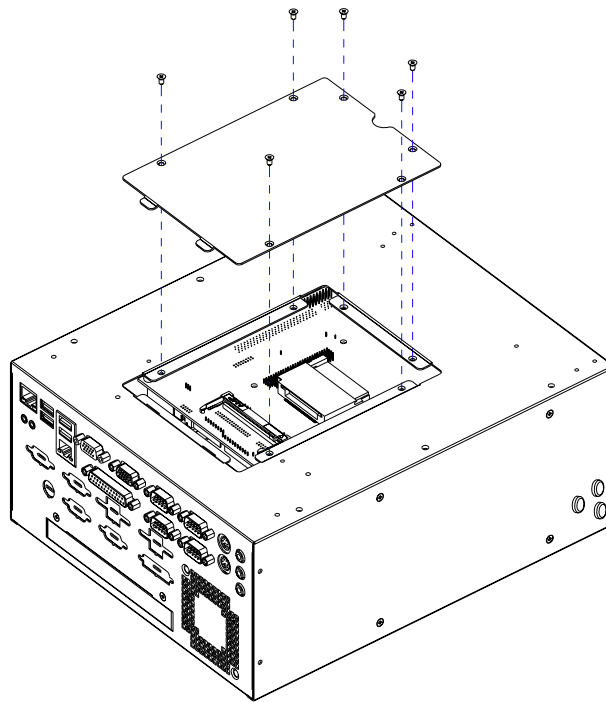

Figure 2.2 Removing the bottom cover for maintenance of the CompactFlash or mini PCI module

2.3 Installing the 5.25" Biscuit SBC

The EBPC-5250 supports the Advantech PCM-958X series of SBCs. To install the SBC, please remove the slim-type ODD bracket first. Then proceed as follows (Figure 2.3):

1. Install the CPU, CPU cooler, RAM, CF or mini PCI module, etc. on the SBC.
2. Fasten the SBC onto the chassis with the four screws provided.
3. Connect the cables provided from the SBC to the front I/O board. (see the detailed cable connection in Chapter 3)
4. Connect the 12-pin power connector from the power supply to the SBC.
5. Connect the power LED, HDD LED and power switch wire from the chassis to the SBC.

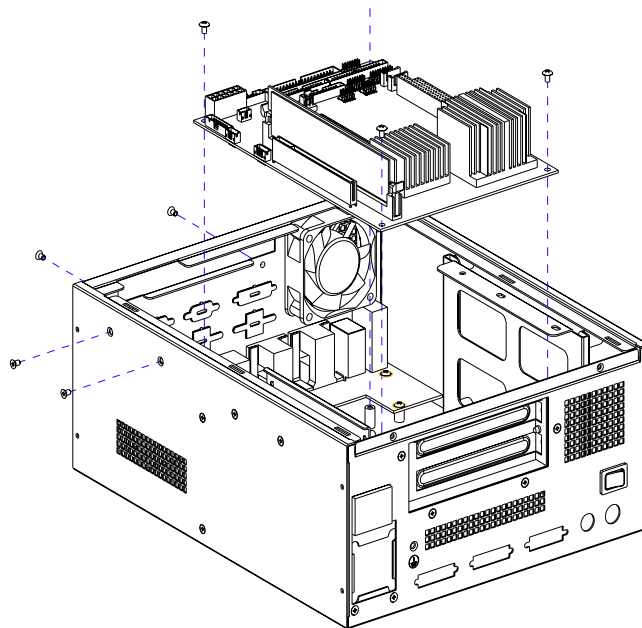

Figure 2.3 Installing an SBC

2.4 Installing a PCI Card or PC/104 Module or Riser Card

The EBPC-5250 can support a PC/104 module or a PCI card depending on the SBC specification. To install the module, simply insert the module in the corresponding slot. Alternatively, it also supports up to 2 PCI cards via the optional riser card. To install the optional riser card, please proceed as follows:

Note! *Use caution when installing a PCI card or PC/104 module, please note the height limit. If users install the PCI card (through the optional riser card) and the PC/104 module at the same time, it may cause a mechanical obstacle if some components on the PCI card or PC/104 module are too high.*



1. Remove the riser card support on top of the power supply with the 2 screws on the outside of the chassis.
2. Fasten the riser card onto the support with the 2 screws provided. Then insert the riser card into the PCI slot of the SBC. (Figure 2.4)
3. When you install the add-on card, please remove the round plastic cap on the chassis so the screwdriver can be inserted to the hole to loosen or fasten the screw on the I/O bracket on the rear plate. (Figure 2.5)
4. Remove the rear I/O bracket and insert a half-size PCI card into the lower slot on the riser card. **When inserting a PCI card into the upper slot, if the length is too long, there may not be enough room for installing the slim-type optical disk drive.**
5. Fasten the add-on card onto the chassis and then replace the round plastic cap.

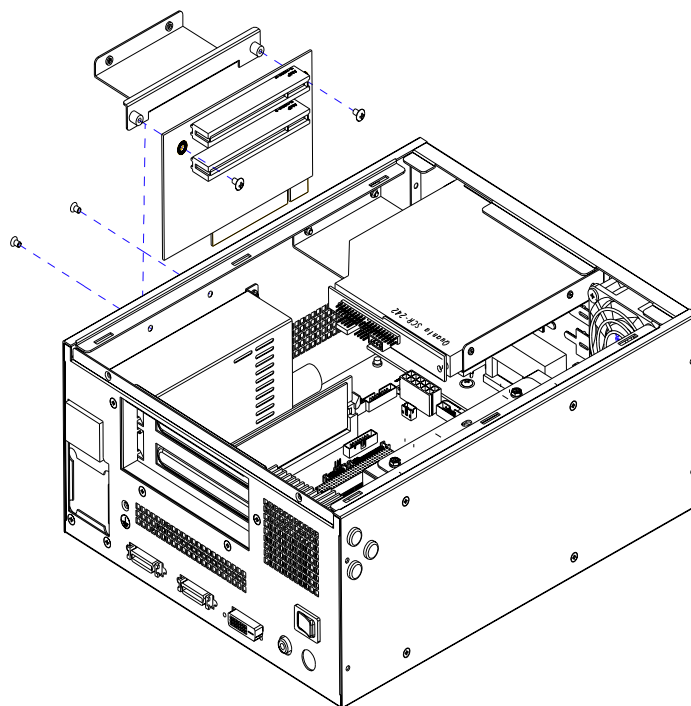

Figure 2.4 Installing a riser card

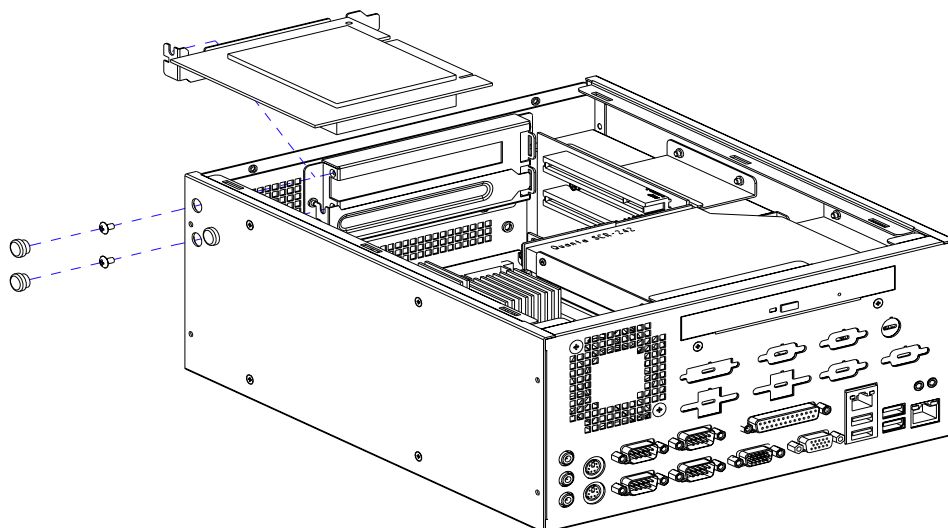

Figure 2.5 Remove the round plastic cap to fasten/loose the screw to the add-on cards

2.5 Installing the Disk Drives

The EBPC-5250 comes with a shockproof housing for an internal 3.5" HDD. It also reserves space for a slim type optical disk drive. Please refer to the following instructions to install the 3.5" hard disk drive and the optical disk drive.

2.5.1 Installing a 3.5" Hard Disk Drive

1. To install the 3.5" internal HDD, remove the disk drive bracket by releasing the four screws (with the rubber cushions) from outside the chassis (see Figure 2.6).
2. Insert the disk drive into the proper bracket location and secure it with the screws provided.
3. Return the disk drive bracket with the 3.5" HDD to the original position and fasten it with the four screws.
4. Connect the IDE flat cable from the SBC; and plug in the power connector from the power supply.

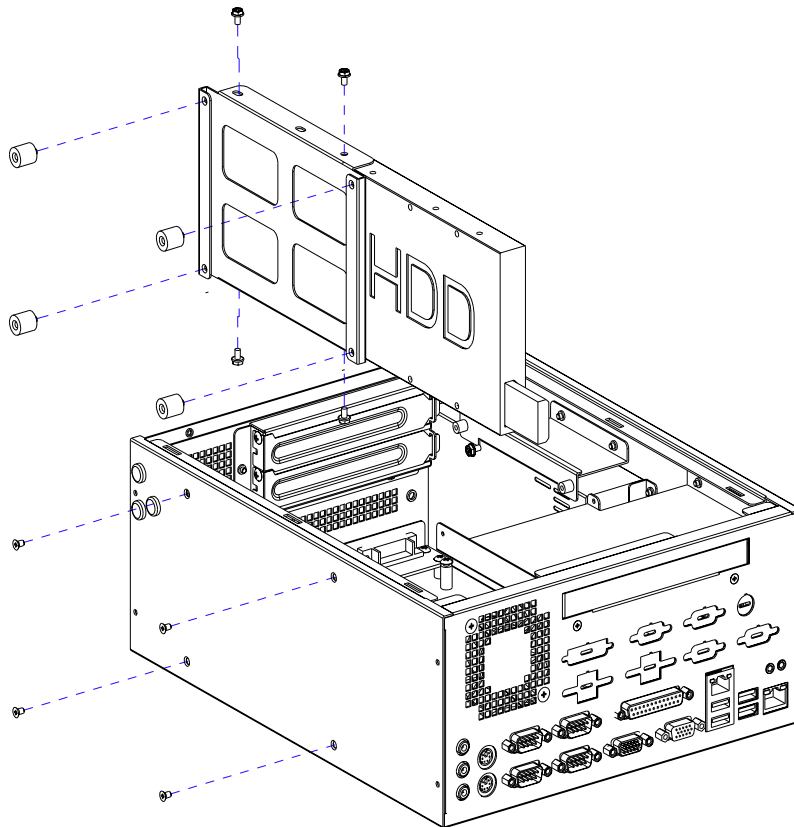

Figure 2.6 Installing a 3.5" HDD

2.5.2 Installing a Slim-type Optical Disk Drive

The EBPC-5250 reserves space for a slim-type optical disk drive. However if it is used, the upper PCI slot on the riser card may not be used. Please follow the installation as listed below.

1. Undo the two screws on the front plate to remove the slim-type ODD bracket (Figure 2.7).
2. Undo the two screws to remove the front cover of the slim-type ODD.
3. Fasten the small converter board (in the accessory package of the slim-type ODD) onto the rear of the slim-type optical disk drive by tightening the two screws provided (See Figure 2.8).
4. Fasten the slim-type optical disk drive to the slim-type ODD bracket.
5. Put the slim-type ODD bracket in place and fasten it onto the chassis with the two screws.
6. Connect the 40-pin IDE flat cable from the SBC. Also plug in the 4-pin power connector from the power supply. Return the bracket to the chassis.

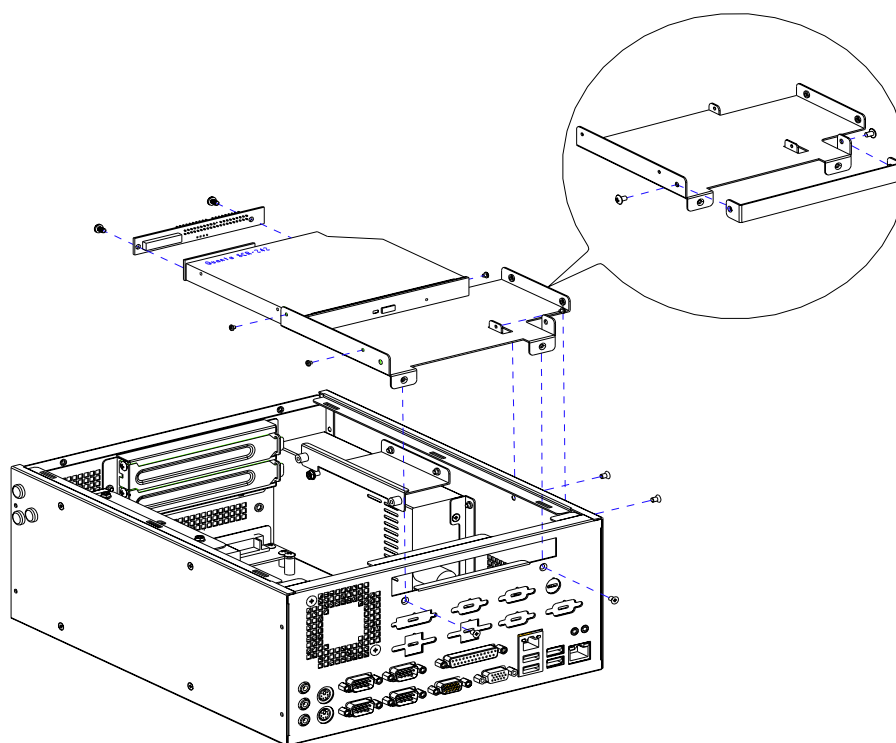

Figure 2.7 Install a slim-type optical disk drive into the chassis

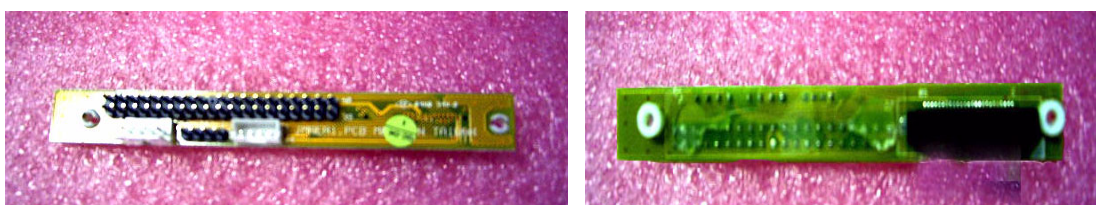

Figure 2.8 Small converter for slim-type optical disk drive

2.6 Attaching the Mounting Brackets

A pair of mounting brackets is included in the accessory box. If you need to install them, please refer to Figure 2.9 which depicts how to fasten them to the bottom-left and bottom-right of the chassis with the six screws provided.

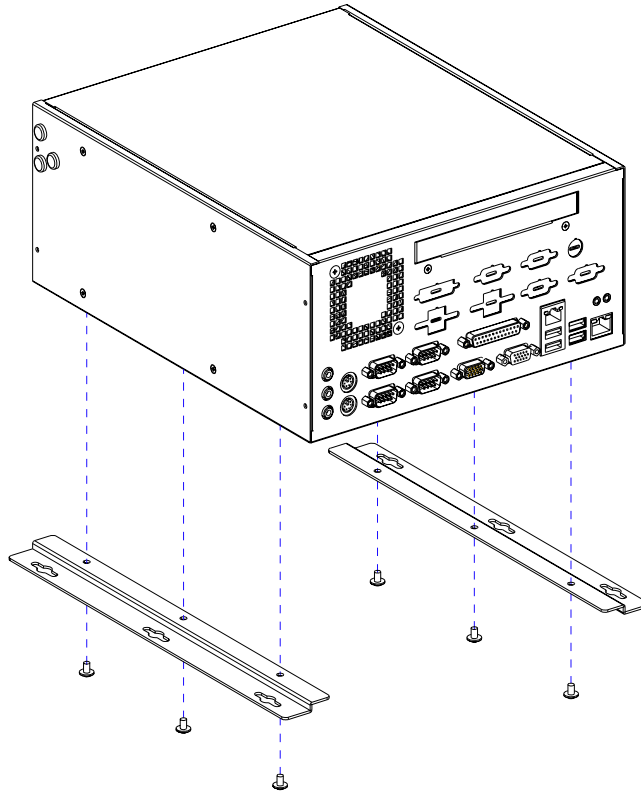

Figure 2.9 Attaching the mounting brackets

Chapter 3

I/O Board, Optional Display Module Kit & Cable Connections

This chapter introduces the I/O board, optional display module kit and cable connections.

Section include:

- I/O Board Layout
- Cable Connections between the 5.25" SBC and I/O Board
- Optional Display Module Layout
- Cable Connections between the SBC & the Display Module Kit

3.1 I/O Board Layout

The layout of the front I/O board is shown below:

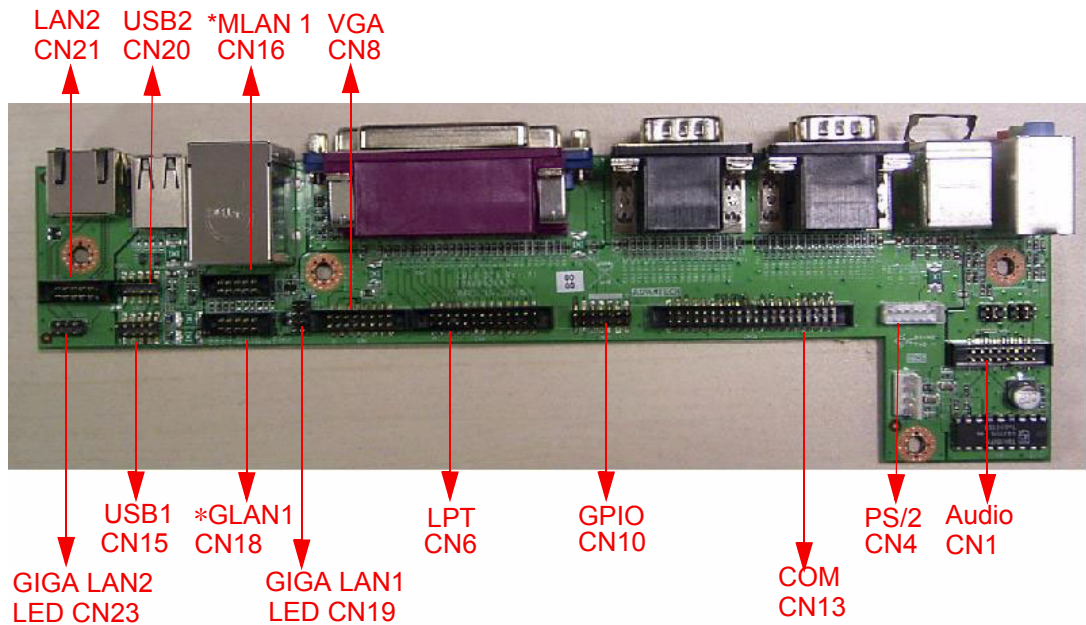

Figure 3.1 Front I/O board layout







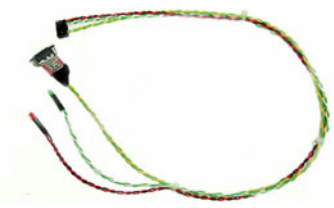

*MLAN1 is 10/100 LAN, *GLAN1 is 10/100/1000 LAN. Depending on the SBC specification, only one of the LAN1 connectors need to be installed.

Note: GPIO Pin Definitions:

CN10 (internal)	Pin	CN9 (D-SUB)	CN10 (internal)	Pin	CN9 (D-SUB)
GPIO0	1	GPIO0	GPIO2	9	X
GPIO4	2	GPIO1	GPIO6	10	X
GND	3	GPIO2	GND	11	Vcc
GND	4	GPIO3	GND	12	Vcc
GPIO1	5	GPIO4	GPIO3	13	GND
GPIO5	6	GPIO5	GPIO7	14	GND
Vcc	7	GPIO6		15	GND
X	8	GPIO7			







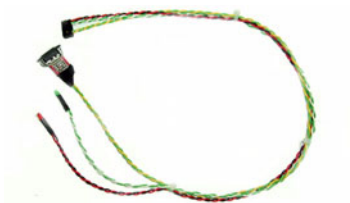

3.2 Cable Connections between the PCM-9581/9586 and I/O Board

Table 3.1: Cable Connections between PCM-9581/9586 and I/O Board

Illustration	Part Number	PCM-9581 PCM-9586	Function	Front I/O board
	1700007921	CN3	Power switch & LED	-
	1700002284	CN23	10/100 LAN	CN18
	1700002365	CN11	COM	CN13
	1700002366	CN4	LPT	CN6
	1700002367	CN13	VGA	CN8
	1700002368	CN9	GPIO	CN10
	1700002437	CN14	Audio	CN1
	1700002591	CN19	KB/MS	CN4
	1700008721	CN25, CN26	USB	CN15, CN20







3.3 Cable Connections between the PCM-9582/9587 and I/O Board

Table 3.2: Cable Connections between PCM-9582/9587 and I/O Board

Illustration	Part Number	PCM-9582 PCM-9587	Function	Front I/O Board
	1700007921	CN22	Power switch & LED	-
	1700002284	CN11	10/100 LAN	CN18
	1700002365	CN21	COM	CN13
	1700002366	CN16	LPT	CN6
	1700002367	CN4	Audio	CN1
	1700002368	CN19	GPIO	CN10
	1700002437	CN7	VGA	CN8
	1700002591	CN19	KB/MS	CN4
	1700008721	CN20, CN18	USB	CN15, CN20

3.4 Cable Connections between the PCM-9584 and I/O Board





Table 3.3: Cable Connections between PCM-9584 and I/O Board

Illustration	Part Number	PCM-9584	Function	Front I/O Board
	1700007921	CN22	Power switch & LED	-
	1700002365	CN19	COM	CN13
	1700002366	CN17	LPT	CN6
	1700002367	CN26	VGA	CN8
	1700002419	CN15	KB/MS	CN4
	1700002437	CN21	Audio	CN1
	1700008721	CN14, CN13	USB	CN15, CN20

3.5 Required Cable Kit Connections between the PCM-9581FG/9582FG/9584 and I/O Board

When purchasing the PCM-9581FG/9582FG/9584 series of SBC, please purchase the appropriate cable kit. The P/N is 9668525004E. The detail of this cable kit is listed below:

Table 3.4: Optional Cable Kit Connections between PCM-9581FG/9582FG/9584 and I/O Board

Illustration	Part Number	PCM-9581FG PCM-9582FG PCM-9584	Function	Front I/O board
	1700002438	CN2	GigaLAN LED	CN19, CN23
	1700002421	CN16	GPIO	CN10
	1700002419	CN15	PS/2 KB/MS	CN4
	1700005051	CN6, CN10	Giga LAN	CN18, CN21

3.6 Optional Display Module Layout

The layout of the optional display module is shown below:

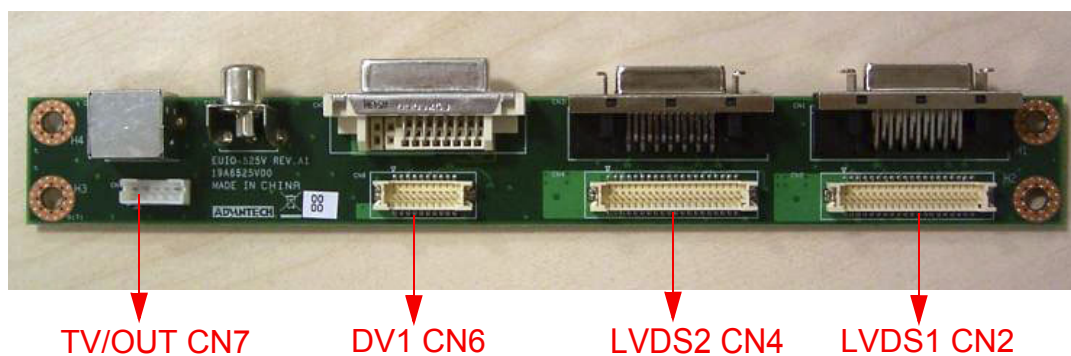





Figure 3.2 Display module layout

3.7 Cable Connections Between the SBC and the Display Module

Table 3.5: Cable Connections Between the SBC and the Display Module

Illustration	Part Number	PCM-9581/86 PCM-9582/87 PCM-9584	Function	Display module
	1700002410	CN11 (9581/86) CN8 (9582/87) CN22, CN25 (9584)	LVDS	CN2, CN4
	1700002422	CN7 (9581/86) CN9 (9582/87)	DVI	CN6
	1700002409	CN2 (9581/86) CN8 (9584)	TV Out	CN7

Chapter 4

Operation

This chapter describes how to maintain the EBPC-5250.

Sections include:

- The Front Plate
- The Rear Plate
- Replacing the Cooling Fan
- Replacing the Power Supply

4.1 The Front Plate

The front panel has a built-in Line-in jack, a Line-out jack, a Mic-in jack, a Mini DIN PS/2 mouse connector, a Mini DIN PS/2 keyboard connector, four COM ports, a parallel port, a GPIO port, a VGA port, four USB ports, a 10/100 LAN port and a Giga LAN port with 'link' & 'activity' LED indicators. The GigaLAN port on the lower right corner is specifically for PCM-9581FG/9582FG/9584 series of biscuit SBC. If users use other 958X series SBCs, there is a cap to cover this port. The front plate also reserves openings to support a DVI, four 9-pin D-SUB, and four USB ports for extra needs. The LEDs indicate the power on/off and the hard disk drive activity. When the system power is on, the POWER LED is always Green. When the HDD LED is blinking Red, it means the HDD is transmitting data.

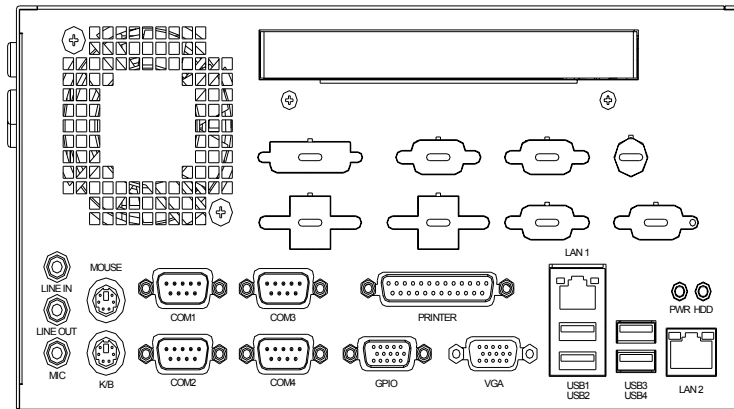

Figure 4.1 Front plate

4.2 The Rear Plate

The rear plate is pre-punched with openings to support two LVDS connectors, a DVI port, an S-Video and a C-Video port for the optional display module kit. The momentary ATX power switch is placed on the rear side to prevent it from being touched by accident.

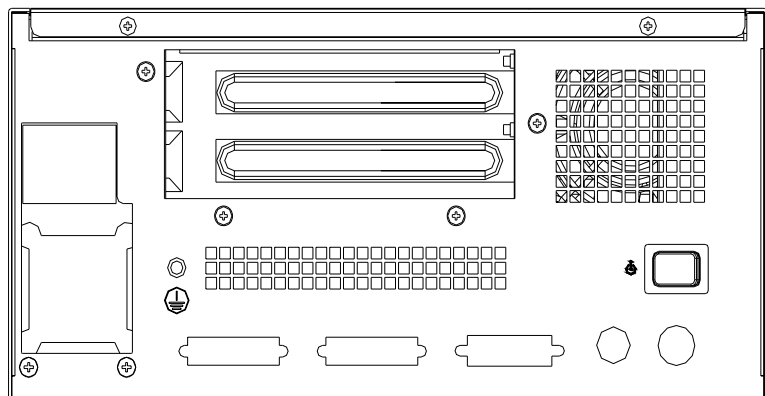

Figure 4.2 Rear plate

4.3 Replacing the Cooling Fan

There is a system cooling fan near the front left of the chassis. To replace the cooling fan, please follow the procedures below:

1. Remove the top cover
2. Unplug the fan power connector.
3. Loosen the four screws on the front plate and take out the fan module. (see Figure 4.3)
4. Remove the two screws on the fan guard.
5. Fasten the fan guard onto a new fan.
6. Return the fan module with the wire facing downward to the chassis and fasten it to the four screws.
7. Plug in the fan power connector.
8. Replace the top cover and fasten it.

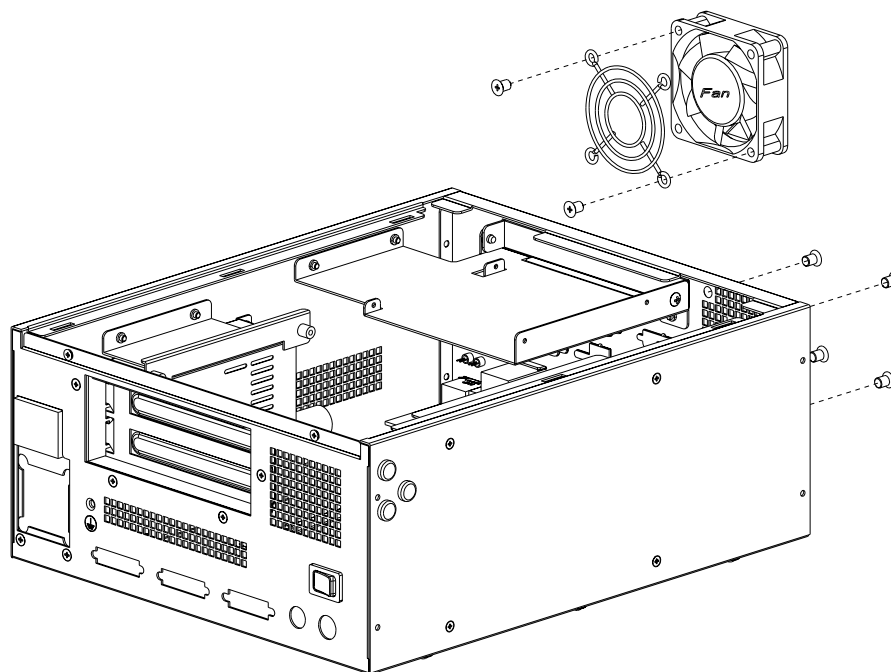

Figure 4.3 Replacing the system fan

4.4 Replacing the Power Supply

The EBPC-5250 supports a single power supply. To replace the power supply, proceed as follows:

1. Unplug the power cord from the power supply.
2. Remove the top cover.
3. Unplug the 12-pin ATX power connector from the SBC, as well as the power connectors from the disk drives and fan.
4. Remove three screws on the rear plate and three screws on the side of the chassis.
5. To remove the power bracket, please loosen the two screws on the riser card first. Then take out the power supply and remove the two screws on the bracket. (see Figure 4.4)
6. Fix a new power supply onto the bracket and then fasten it onto the chassis.
7. Plug the 12-pin ATX power connector to the SBC. And plug other power connectors to the disk drives and fan.
8. Return the top cover and fasten it. Then plug in the power cord.

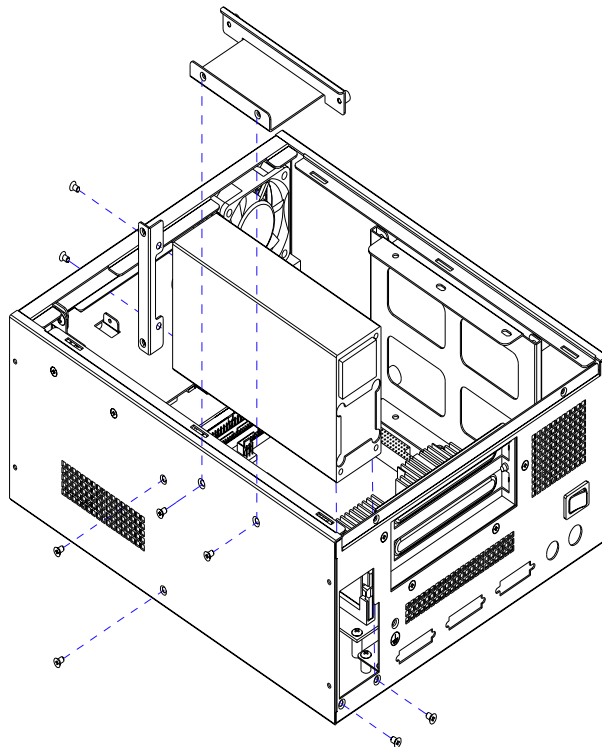

Figure 4.4 Replacing the power supply

Appendix **A**

Exploded Diagram and Parts List

This appendix shows the exploded diagram and parts list of the EBPC-5250.

A.1 Exploded Diagram and Parts List

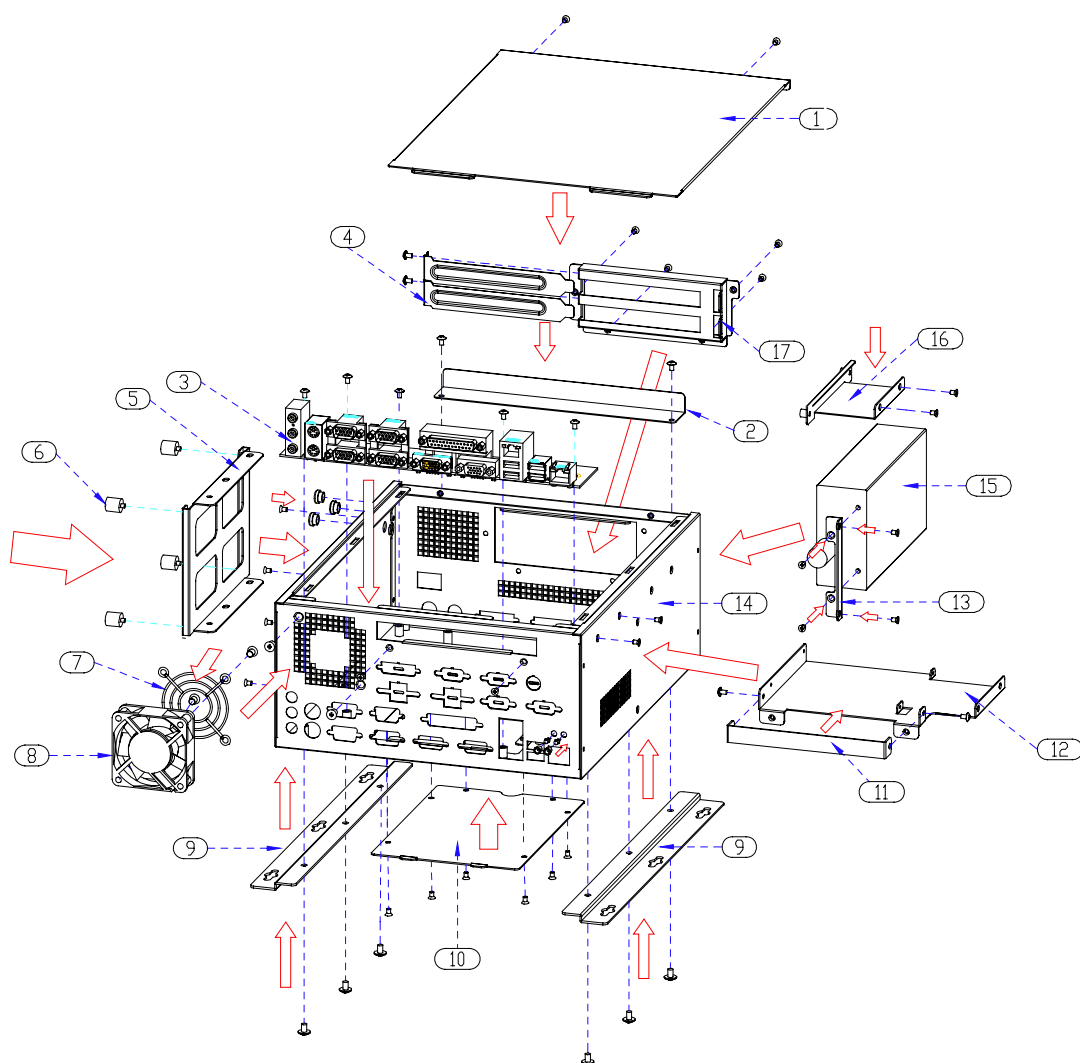

Figure A.1 Exploded diagram

Table A.1: Parts List

1. Top cover	10. Bottom cover
2. Display module cover	11. Slim optical disk drive front cover
3. I/O board	12. Slim optical disk drive bracket
4. Adapter bracket	13. Power supply bracket
5. HDD bracket	14. Chassis
6. Rubber cushion	15. Power supply
7. Fan guard	16. Riser card bracket
8. Fan module	17. Rear window
9. Mounting bracket	

Appendix **B**

5.25" Biscuit SBC Options

This appendix shows the 5.25" SBC options.

B.1 5.25" Biscuit SBC Options

EBPC-5250 supports a variety of Advantech 5.25" biscuit SBCs (listed below). Users can contact a local sales representative for detailed information.

Table B.1: 5.25" Biscuit SBC Options

Model Name	Slot				
	PCI	Mini PCI	PC/104	PC/104+	PCI-104
PCM-9581	1	1	-	-	-
PCM-9582	1	1	1	-	1
PCM-9584	1	1	1	-	-
PCM-9586	1	1	-	-	-
PCM-9587	1	1	1	-	1

* If the user chooses the PCM-9581FG/9582FG/9584, please purchase the necessary cable kit. The P/N is 9668525004E.

Trusted ePlatform Services

ADVANTECH

www.advantech.com

Please verify specifications before quoting. This guide is intended for reference purposes only.

All product specifications are subject to change without notice.

No part of this publication may be reproduced in any form or by any means, electronic, photocopying, recording or otherwise, without prior written permission of the publisher.

All brand and product names are trademarks or registered trademarks of their respective companies.

© Advantech Co., Ltd. 2008