

**INSTALLER: THESE INSTRUCTIONS MUST BE CONVEYED TO AND REMAIN WITH THE HOMEOWNER.**

CERTIFIED UNDER CANADIAN AND AMERICAN NATIONAL STANDARDS, CSA 2.33, ANSI Z21.88 FOR VENTED GAS FIREPLACE HEATERS



# STARfire™

## VENTED GAS FIREPLACE HEATER DIRECT VENT MILLIVOLT SYSTEM

INSTALLATION AND OPERATION INSTRUCTIONS FOR:

NATURAL GAS *MODEL GD70NT-S*  
PROPANE GAS *MODEL GD70PT-S*

CERTIFIED FOR CANADA AND UNITED STATES USING ANSI / CSA METHODS

**WARNING:** If the information in these instructions is not followed exactly, a fire or explosion may result causing property damage, personal injury or death.

### **FOR YOUR SAFETY**

Do not store or use gasoline or other flammable vapours and liquids in the vicinity of this or any other appliance.

### **WHAT TO DO IF YOU SMELL GAS:**

- Do not try to light any appliance.
- Do not touch any electrical switch.
- Do not use any phone in your building.
- Immediately call your gas supplier from a neighbor's phone. Follow the gas supplier's instructions.
- If you cannot reach your gas supplier, call the fire department.

Installation and service must be performed by a qualified installer, service agency or the gas supplier.



Wolf Steel Ltd., 24 Napoleon Rd., Barrie, ON L4M 4Y8 Canada • (705)721-1212 • fax(705)722-6031

[www.napoleonfireplaces.com](http://www.napoleonfireplaces.com) • [ask@napoleon.on.ca](mailto:ask@napoleon.on.ca)

## TABLE of CONTENTS

<b>PG2-5</b>	<b>INTRODUCTION</b> Warranty Dimensions General Instructions General Information Care of Glass & Plated Parts	<b>20</b>	<b>BLOWER INSTALLATION THERMODISC REPLACEMENT</b>
<b>5-10</b>	<b>VENTING</b> Vent lengths Venting Specifications Air Terminal Locations	<b>21-22</b>	<b>OPERATION / MAINTENANCE</b> Operating Instructions Maintenance
<b>11-15</b>	<b>INSTALLATION/FRAMING</b> Wall & Ceiling Protection Using Flexible Vent Components Fireplace Vent Connection Using Rigid Vent Components Restricting Vertical Vents Gas Installation Mobile Home Installation Framing Mantle Clearances and Enclosures	<b>22</b>	<b>ADJUSTMENTS</b> Pilot Burner Adjustment Venturi Adjustment
<b>16-19</b>	<b>FINISHING</b> Door Installation Door Opening and Closing Louvre Installation Log Shipping Bracket Removal Decorative Panels Charcoal Strips Log Placement Baffle Installation Charcoal Embers Accent Lite Replacement	<b>23-24</b>	<b>REPLACEMENTS</b> Ordering Replacement Parts Replacement Parts Terminal Kits Vent Kits Accessories
		<b>25-26</b>	<b>TROUBLE SHOOTING GUIDE</b>
		<b>27</b>	<b>SERVICE HISTORY</b>

## PLEASE RETAIN THIS MANUAL FOR FUTURE REFERENCE

### WARNING

- Do not burn wood or other materials in this fireplace.
- Adults and especially children should be alerted to the hazards of high surface temperatures and should stay away to avoid burns or clothing ignition. Supervise young children when they are in the same room as the fireplace.
- Due to high temperatures, the fireplace should be located out of traffic and away from furniture and draperies.
- Clothing or other flammable material should not be placed on or near the fireplace.
- Any safety screen or guard removed for servicing must be replaced prior to operating the fireplace.
- It is imperative that the control compartments, burners and circulating blower and its passageway in the fireplace and venting system are kept clean. The fireplace and its venting system should be inspected before use and at least annually by a qualified service person. More frequent cleaning may be required due to excessive lint from carpeting, bedding material, etc. The fireplace area must be kept clear and free from combustible materials, gasoline and other flammable vapours and liquids.
- Under no circumstances should this fireplace be modified.
- This fireplace must not be connected to a chimney flue pipe serving a separate solid fuel burning appliance.
- Do not use this fireplace if any part has been under water. Immediately call a qualified service technician to inspect the fireplace and to replace any part of the control system and any gas control which has been under water.
- Do not operate the fireplace with the glass door removed, cracked or broken. Replacement of the glass should be done by a licensed or qualified service person.
- Do not strike or slam shut the fireplace glass door.
- This fireplace uses and requires a fast acting thermocouple. Replace only with a fast acting thermocouple supplied by Wolf Steel Ltd.

**NOTE:** Changes, other than editorial, are denoted by a vertical line in the margin.

*NAPOLEON gas fireplaces are manufactured under the strict Standard of the world recognized ISO 9001 : 2000 Quality Assurance Certificate.*

*NAPOLEON products are designed with superior components and materials, assembled by trained craftsmen who take great pride in their work. The burner and valve assembly are leak and test-fired at a quality test station. The complete fireplace is thoroughly inspected by a qualified technician before packaging to ensure that you, the customer, receives the quality product that you expect from NAPOLEON.*

## **NAPOLEON GAS FIREPLACE PRESIDENT'S LIFETIME LIMITED WARRANTY**

*The following materials and workmanship in your new napoleon gas fireplace are warranted against defects for as long as you own the fireplace. This covers: combustion chamber, heat exchanger, stainless steel burner, PHAZER™ logs and embers, ceramic glass (thermal breakage only), gold plated parts against tarnishing, porcelainized enamelled components and aluminum extrusion trims.*

*Electrical (110V and millivolt) components and wearable parts such as the blower, gas valve, thermal switch, switches, wiring, remote control, ignitor, gasketing, and pilot assembly are covered and NAPOLEON will provide replacement parts free of charge during the first year of the limited warranty. Light bulbs are not covered by this warranty.*

*Labour related to warranty repair is covered free of charge during the first year. Repair work, however, requires the prior approval of an authorized company official. Labour costs to the account of NAPOLEON are based on a pre-determined rate schedule and any repair work must be done through an authorized NAPOLEON dealer.*

## **CONDITIONS AND LIMITATIONS**

NAPOLEON warrants its products against manufacturing defects to the original purchaser only -- i.e., the individual or legal entity (registered customer) whose name appears on the warranty registration card filed with NAPOLEON -- provided that the purchase was made through an authorized NAPOLEON dealer and is subject to the following conditions and limitations:

This factory warranty is nontransferable and may not be extended whatsoever by any of our representatives.

The gas fireplace must be installed by a licenced, authorized service technician or contractor. Installation must be done in accordance with the installation instructions included with the product and all local and national building and fire codes.

This limited warranty does not cover damages caused by misuse, lack of maintenance, accident, alterations, abuse or neglect and parts installed from other manufacturers will nullify this warranty.

This limited warranty further does not cover any scratches, dents, corrosion or discolouring caused by excessive heat, abrasive and chemical cleaners nor chipping on porcelain enamel parts, mechanical breakage of PHAZER™ logs and embers, nor any venting components used in the installation of the fireplace.

NAPOLEON warrants its stainless steel burners against defects in workmanship and material for life, subject to the following conditions: During the first 10 years NAPOLEON will replace or repair the defective parts at our option free of charge. From 10 years to life, NAPOLEON will provide replacement burners at 50% of the current retail price.

In the first year only, this warranty extends to the repair or replacement of warranted parts which are defective in material or workmanship provided that the product has been operated in accordance with the operation instructions and under normal conditions.

After the first year, with respect to this President's Limited Lifetime Warranty, NAPOLEON may, at its discretion, fully discharge all obligations with respect to this warranty by refunding to the original warranted purchaser the wholesale price of any warranted but defective part(s).

After the first year, NAPOLEON will not be responsible for installation, labour or any other costs or expenses related to the reinstallation of a warranted part, and such expenses are not covered by this warranty.

Notwithstanding any provisions contained in this President's Limited Lifetime Warranty, NAPOLEON'S responsibility under this warranty is defined as above and it shall not in any event extend to any incidental, consequential or indirect damages.

This warranty defines the obligations and liability of NAPOLEON with respect to the NAPOLEON gas fireplace and any other warranties expressed or implied with respect to this product, its components or accessories are excluded.

NAPOLEON neither assumes, nor authorizes any third party to assume, on its behalf, any other liabilities with respect to the sale of this product. NAPOLEON will not be responsible for: over-firing, downdrafts, spillage caused by environmental conditions such as rooftops, buildings, nearby trees, hills, mountains, inadequate vents or ventilation, excessive venting configurations, insufficient makeup air, or negative air pressures which may or may not be caused by mechanical systems such as exhaust fans, furnaces, clothes dryers, etc.

Any damages to fireplace, combustion chamber, heat exchanger, brass trim or other component due to water, weather damage, long periods of dampness, condensation, damaging chemicals or cleaners will not be the responsibility of NAPOLEON.

The bill of sale or copy will be required together with a serial number and a model number when making any warranty claims from your authorized dealer. The warranty registration card must be returned within fourteen days to register the warranty.

NAPOLEON reserves the right to have its representative inspect any product or part thereof prior to honouring any warranty claim.

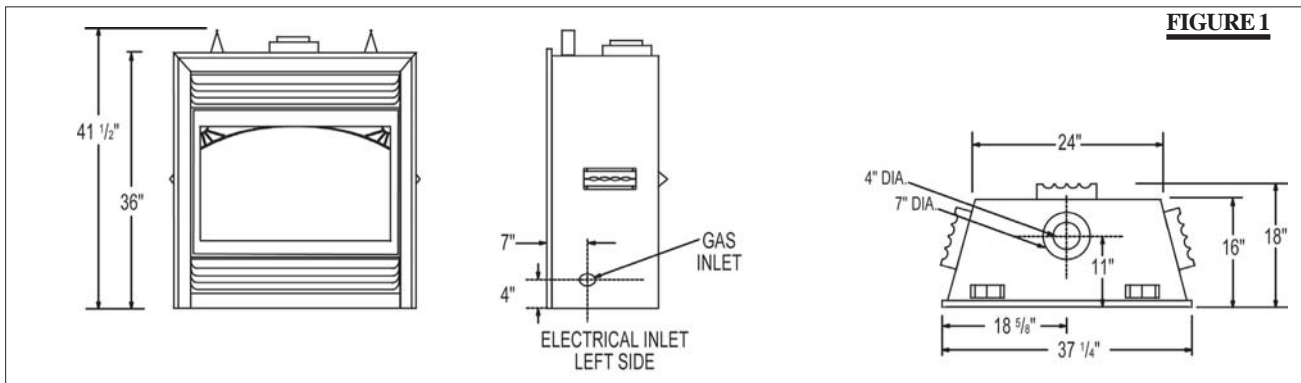

FIGURE 1

**WARNING: The door for this fireplace is sold separately. The door must be installed and closed before operation begins. Refer to "DOOR INSTALLATION" under the "FINISHING" Section for details.**

## GENERAL INSTRUCTIONS

THIS GAS FIREPLACE SHOULD BE INSTALLED AND SERVICED BY A QUALIFIED INSTALLER to conform with local codes. Installation practices vary from region to region and it is important to know the specifics that apply to your area,

for example: in [Massachusetts State](#):

- The fireplace damper must be removed or welded in the open position prior to installation of a fireplace insert or gas log.
- The appliance off valve must be a "T" handle gas cock.
- The flexible connector must not be longer than 36 inches.
- The appliance is not approved for installation in a bedroom or bathroom unless the unit is a direct vent sealed combustion product.
- WARNING: This product must be installed by a licensed plumber or gas fitter when installed within the commonwealth of Massachusetts.

In absence of local codes, install to the current CAN/CGA - B149 Installation Code in Canada or to the National Fuel Gas Code, ANSI Z223.1, and NFPA 54 in the United States. Suitable for mobile home installation if installed in accordance with the current standard CAN/CSA Z240MH Series, for gas equipped mobile homes, in Canada or ANSI Z223.1 and NFPA 54 in the United States.

The fireplace and its individual shutoff valve must be disconnected from the gas supply piping system during any pressure testing of that system at test pressures in excess of 1/2 psig (3.5 kPa). The fireplace must be isolated from the gas supply piping system by closing its individual manual shutoff valve during any pressure testing of the gas supply piping system at test pressures equal to or less than 1/2 psig (3.5 kPa).

When the fireplace is installed directly on carpeting, vinyl tile or other combustible material other than wood flooring, the fireplace shall be installed on a metal or wood panel extending the full width and depth.

The optional heat circulating blower is supplied with a cord. If installed, the junction box must be electrically connected and grounded in accordance with local codes. In the absence of local codes, use the current CSA C22.1 CANADIAN ELECTRICAL CODE in Canada or the ANSI/NFPA 70 NATIONAL ELECTRICAL CODE in the United States.

*Purge all gas lines with the glass door of the fireplace open. Assure that a continuous gas flow is at the burner before closing the door.*

*Under extreme vent configurations, allow several minutes (5-15) for the flame to stabilize after ignition.*

*Eight (8") inches is the minimum bend radius allowed for the 7" diameter flexible air liner.*

*Provide adequate ventilation and combustion air. Provide adequate accessibility clearance for servicing and operating the fireplace. Never obstruct the front opening of the fireplace.*

*Objects placed in front of the fireplace must be kept a minimum of 48" from the front face of the unit.*

### Minimum clearance to combustible construction from fireplace and vent surfaces:

fireplace framing	- 0" to stand-offs (top, rear and sides)
fireplace finishing	- 3" to sides, 7/4" to top of unit
vent pipe	- 2 inches *
recessed depth	- 16 inches

\* The first 2 feet of outer 7 inch diameter vent pipe from the appliance must be wrapped in the 1" thick insulation sleeve (supplied). There must be a 1inch air gap in addition to the insulation sleeve. **See Figure 34.**

## GENERAL INFORMATION

**FOR YOUR SATISFACTION, THIS FIREPLACE HAS BEEN TEST-FIRED TO ASSURE ITS OPERATION AND QUALITY!**

Maximum input is 35,000 BTU/hr for natural gas and 33,000 BTU/hr for propane. When the fireplace is installed at elevations above 4,500ft, and in the absence of specific recommendations from the local authority having jurisdiction, the certified high altitude input rating shall be reduced at the rate of 4% for each additional 1,000ft. Maximum output for natural gas is 28,350 BTU/hr at an efficiency of 81%; and 26,400 BTU/hr for propane at an efficiency of 80%. Minimum A.F.U.E. rating is 64% for natural gas and 65% for propane. Minimum inlet gas supply pressure is 4.5 inches water column for natural gas and 11 inches water column for propane. Maximum inlet gas pressure is 7 inches water column for natural gas and 13 inches water column for propane. Manifold pressure under flow conditions is 3.5 inches water column for natural gas and 10 inches water column for propane.

This fireplace is approved for bathroom, bedroom and bed-sitting room installations and is suitable for mobile home installation. The natural gas model can only be installed in a mobile home that is permanently positioned on its site and fueled with natural gas.

***This fireplace may be installed in an aftermarket permanently located, manufactured (mobile) home, where not prohibited by local codes.***

***This fireplace is only for use with the type of gas indicated on the rating plate. This fireplace is not convertible for use with other gases, unless a certified kit is used.***

***No external electricity (110 volts or 24 volts) is required for the gas system operation.***

Expansion / contraction noises during heating up and cooling down cycles are normal and are to be expected. Change in flame appearance from "HI" to "LO" is more evident in natural gas than in propane.

## VENTING

### VENTING LENGTHS & AIR TERMINAL LOCATIONS

Use only Wolf Steel, Simpson Dura-Vent, **Selkirk Direct Temp** or **American Metal Amerivent** venting components. Minimum and maximum vent lengths, for both horizontal and vertical installations, and air terminal locations for either system are set out in this manual and must be adhered to. For Simpson Dura-Vent, **Selkirk Direct Temp** and **American Metal Amerivent**, follow the installation procedure provided with the venting components.

For vent systems that provide seals on the inner exhaust flue, only the outer air intake joints must be sealed using a red high temperature silicone (RTV). This same sealant maybe used on both the inner exhaust and outer intake vent pipe joints of all other approved vent systems except for the exhaust vent pipe connection to the fireplace flue collar which must be sealed using the black high temperature sealant Mill Pac. High temperature sealant must be ordered separately.

When using Napoleon venting components, use only approved Wolf Steel Ltd. rigid / flexible vent components with the following termination kits: WALL TERMINAL KIT GD222, or 1/12 TO 7/12 PITCH ROOF TERMINAL KIT GD110, 8/12 TO 12/12 ROOF TERMINAL KIT GD111, FLAT ROOF TERMINAL KIT GD112 or PERISCOPE KIT GD201 (for wall penetration below grade). With flexible venting, in conjunction with the various terminations, use either the 5 foot vent kit GD220 or the 10 foot vent kit GD330. These vent kits allow for either horizontal or vertical venting of the fireplace. FIGURES 2, 3, & 5.

***The maximum allowable vertical vent length is 40 feet.*** The maximum number of allowable 4" vent connections is **three horizontally** or **vertically** (excluding the fireplace and the air terminal connections) when using aluminum flexible venting.

For optimum flame appearance and fireplace performance, keep the vent length and number of elbows to a minimum. The air terminal must remain unobstructed at all times. Examine the air terminal at least once a year to verify that it is unobstructed and undamaged.

***When venting, the horizontal run must be kept to a minimum of 12 inches or a maximum of 20 feet. If a 20 foot horizontal run is required, the fireplace must have a minimum vertical rise immediately off the fireplace of 57 inches. FIGURES 2a-c. When terminating vertically, the vertical rise is a minimum 34 inches and a maximum 40 feet above the fireplace. FIGURE 3.***

***Horizontal runs may have a 0 inch rise per foot in all cases using SIMPSON DURA-VENT or NAPOLEON RIGID OR FLEXIBLE venting components when venting as illustrated in Figures 2a, 2b, and 2c.***

### CARE OF GLASS, AND PLATED PARTS

Do not use abrasive cleaners to clean plated parts. Buff lightly with a clean dry cloth. The glass is 3/16" ceramic glass available from your Napoleon / Wolf Steel Ltd. dealer. DO NOT SUBSTITUTE MATERIALS. Clean the glass after the first 10 hours of operation with a recommended gas fireplace glass cleaner. Thereafter clean as required. DO NOT CLEAN GLASS WHEN HOT! If the glass is not kept clean permanent discoloration and / or blemishes may result.

FIGURES 2a-c

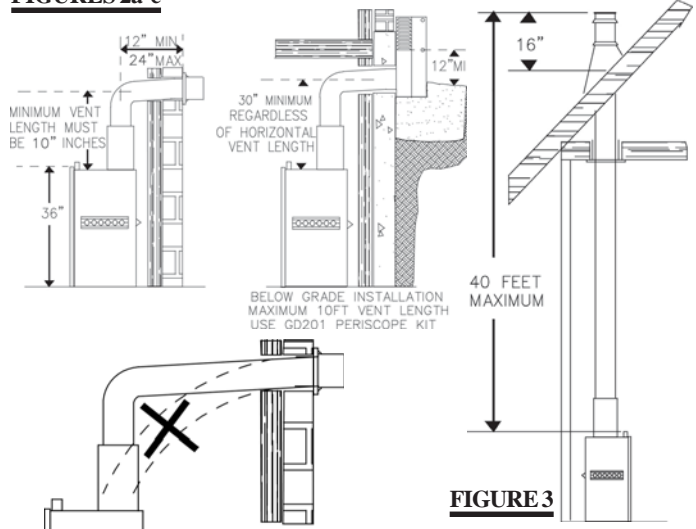

***For optimum performance, it is recommended that all horizontal runs have a minimum ¼ inch rise per foot. Wolf Steel rigid and flexible venting systems must not be combined.***

***Wolf Steel, Simpson Dura-Vent, Selkirk Direct Temp and American Metal Amerivent venting systems must not be combined.***

***Provide a means for visually checking the vent connection to the fireplace after the fireplace is installed.***

***Do not allow the inside liner to bunch up on horizontal or vertical runs and elbows. Keep it pulled tight. A 1¼" air gap between the inner and outer liner all around is required for safe operation.***

***Vent lengths that pass through unheated spaces (attics, garages, crawl space) should be wrapped with a protective insulation sleeve to minimize condensation.***

***Use a firestop when penetrating interior walls, floor or ceiling.***

***In order to avoid the possibility of exposed insulation or vapour barrier coming in contact with the fireplace body, it is recommended that the walls of the fireplace enclosure be 'finished', (i.e. drywall/sheetrock) as would any other outside wall of the home. This will ensure that clearance to combustibles is maintained within the cavity.***

***For safe and proper operation of the fireplace follow the venting instruction exactly.***

***Deviation from the minimum vertical vent length can create difficulty in burner start-up and/or carboning.***

**DEFINITIONS**

for the following symbols used in the venting calculations and examples are:

- > - greater than
- ≥ - equal to or greater than
- < - less than
- ≤ - equal to or less than
- H<sub>T</sub>** - total of both horizontal vent lengths (**H<sub>R</sub>**) and offsets (**H<sub>O</sub>**) in feet
- H<sub>R</sub>** - combined horizontal vent lengths in feet
- H<sub>O</sub>** - offset factor: .03(total degrees of offset - 90°\*) in feet
- V<sub>T</sub>** - combined vertical vent lengths in feet

**ELBOW VENT LENGTH VALUES**

	feet	inches
1°	0.03	0.5
15°	0.45	6.0
30°	0.9	11.0
45°	1.35	16.0
90°*	2.7	32.0

\* the first 90° offset has a zero value and is shown in the formula as **-90°**

**TOP EXIT / HORIZONTAL TERMINATION**

when **(H<sub>T</sub>) ≤ (V<sub>T</sub>)**

Simple venting configuration (only one 90° elbow)

**FIGURE 4**

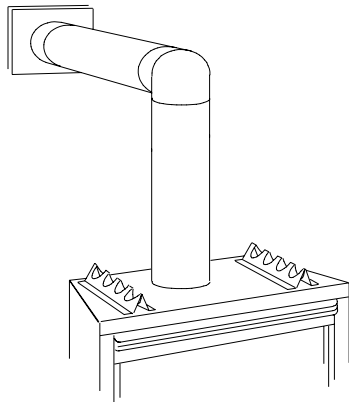

See graph to determine the required vertical rise **V<sub>T</sub>** for the required horizontal run **H<sub>T</sub>**.

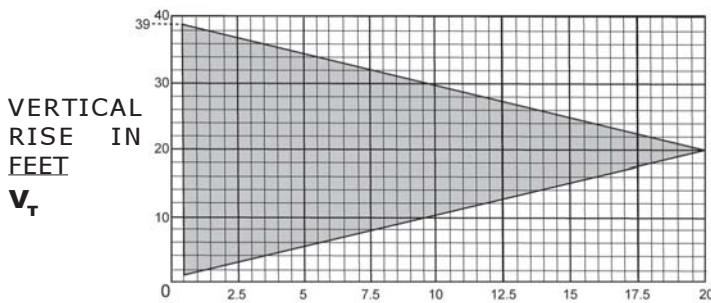

HORIZONTAL VENT RUN PLUS OFFSET IN FEET **H<sub>T</sub>**

The shaded area within the lines represents acceptable values for **H<sub>T</sub>** and **V<sub>T</sub>**.

For vent configurations requiring more than one 90° elbow, the following formulas apply:

**Formula 1: H<sub>T</sub> ≤ V<sub>T</sub>**

**Formula 2: H<sub>T</sub> + V<sub>T</sub> ≤ 40 feet**

**Example 1:**

**FIGURE 5**

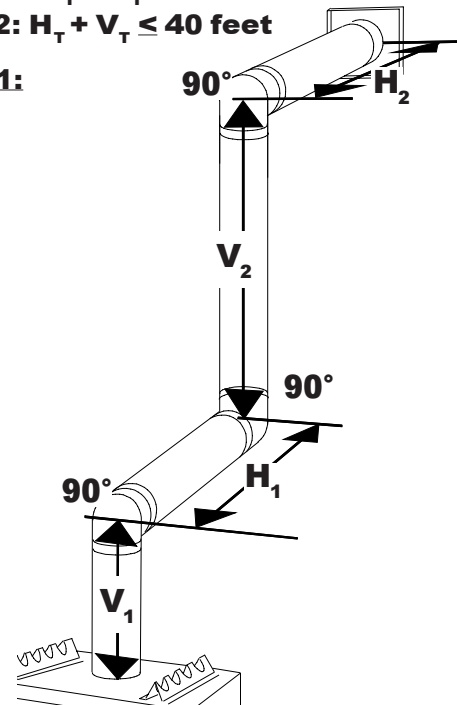

**V<sub>1</sub>** = 3 ft  
**V<sub>2</sub>** = 8 ft  
**V<sub>T</sub>** = **V<sub>1</sub>** + **V<sub>2</sub>** = 3 + 8 = 11 ft

**H<sub>1</sub>** = 2.5 ft  
**H<sub>2</sub>** = 2 ft  
**H<sub>R</sub>** = **H<sub>1</sub>** + **H<sub>2</sub>** = 2.5 + 2 = 4.5 ft

**H<sub>O</sub>** = .03(three 90° elbows - 90°) = .03(270° - 90°) = 5.4 ft

**H<sub>T</sub>** = **H<sub>R</sub>** + **H<sub>O</sub>** = 4.5 + 5.4 = 9.9 ft

**H<sub>T</sub> + V<sub>T</sub>** = 9.9 + 11 = 20.9 ft

Formula 1: **H<sub>T</sub> ≤ V<sub>T</sub>**  
 9.9 ≤ 11

Formula 2: **H<sub>T</sub> + V<sub>T</sub> ≤ 40 feet**  
 20.9 ≤ 40

Since both formulas are met, this vent configuration is acceptable.

# TOP EXIT / HORIZONTAL TERMINATION

when  $(H_T) > (V_T)$

Simple venting configuration (only one 90° elbow)

**FIGURE 6**

See graph to determine the required vertical rise  $V_T$  for the required horizontal run  $H_T$ .

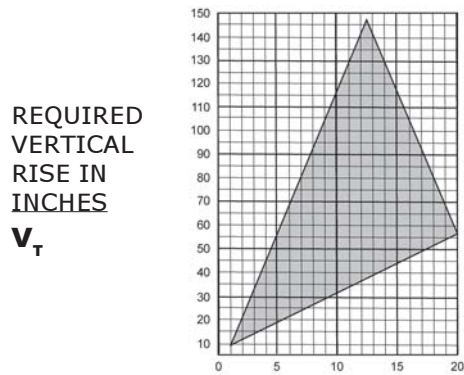

HORIZONTAL VENT RUN PLUS OFFSET IN FEET  $H_T$

The shaded area within the lines represents acceptable values for  $H_T$  and  $V_T$ .

For vent configurations requiring more than one 90° elbow the following formulas apply:

Formula 1:  $H_T \leq 4.2 V_T$

Formula 2:  $H_T + V_T \leq 24.75$  feet

**Example 2:**

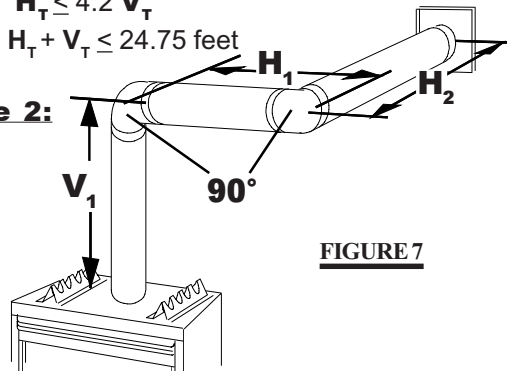

**FIGURE 7**

$V_1 = V_T = 6$  ft

$H_1 = 3$  ft

$H_2 = 5$  ft

$H_R = H_1 + H_2 = 3 + 5 = 8$  ft

$H_O = .03(\text{two } 90^\circ \text{ elbows} - 90^\circ) = .03(180^\circ - 90^\circ) = 2.7$  ft

$H_T = H_R + H_O = 8 + 2.7 = 10.7$  ft

$H_T + V_T = 10.7 + 6 = 16.7$

Formula 1:  $H_T \leq 4.2 V_T$   
 $4.2 V_T = 4.2 \times 6 = 25.2$   
 $10.7 \leq 25.2$

Formula 2:  $H_T + V_T \leq 24.75$  feet  
 $16.7 \leq 24.75$

Since both formulas are met, this vent configuration is acceptable.

**Example 3:**

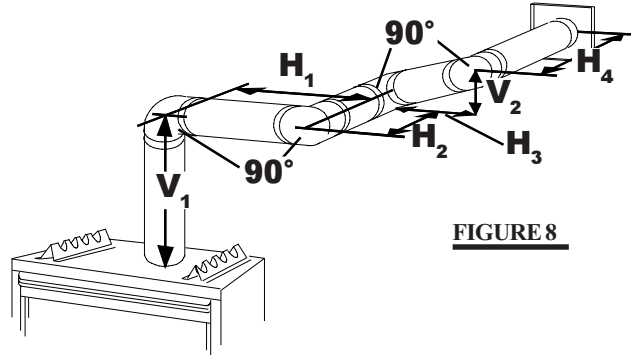

**FIGURE 8**

$V_1 = 4$  ft

$V_2 = 1.5$  ft

$V_T = V_1 + V_2 = 4 + 1.5 = 5.5$  ft

$H_1 = 2$  ft

$H_2 = 1$  ft

$H_3 = 1$  ft

$H_4 = 1.5$  ft

$H_R = H_1 + H_2 + H_3 + H_4 = 2 + 1 + 1 + 1.5 = 5.5$  ft

$H_O = .03(\text{four } 90^\circ \text{ elbows} - 90^\circ) = .03(360^\circ - 90^\circ) = 8.1$  ft

$H_T = H_R + H_O = 5.5 + 8.1 = 13.6$  ft

$H_T + V_T = 13.6 + 5.5 = 19.1$  ft

Formula 1:  $H_T \leq 4.2 V_T$

$4.2 V_T = 4.2 \times 5.5 = 23.1$  ft

$13.6 \leq 23.1$

Formula 2:  $H_T + V_T \leq 24.75$  feet

$19.1 \leq 24.75$

Since both formulas are met, this vent configuration is acceptable.

# VERTICAL TERMINATION

when  $(H_T) \leq (V_T)$

Simple venting configurations

**FIGURE 9**

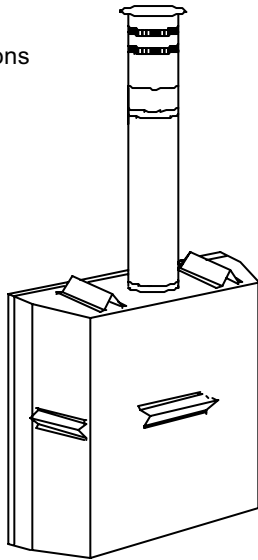

See graph to determine the required vertical rise  $V_T$  for the required horizontal run  $H_T$ .

REQUIRED  
VERTICAL RISE  
IN FEET  
 $V_T$

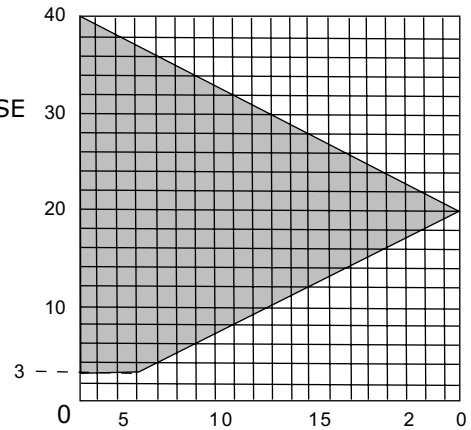

HORIZONTAL VENT RUN PLUS OFFSET IN FEET  $H_T$

*The shaded area within the lines represents acceptable values for  $H_T$  and  $V_T$ .*

For vent configurations requiring more than zero 90° elbow (top exit) or one 90° elbow (rear exit), the following formulas apply:

**Formula 1:  $H_T \leq V_T$**

**Formula 2:  $H_T + V_T \leq 40$  feet**



# VERTICAL TERMINATION

when  $(H_T) > (V_T)$   
Simple venting configurations

**FIGURE 10**

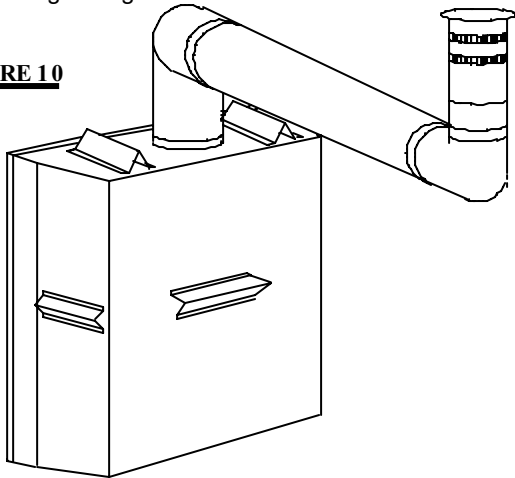

See graph to determine the required vertical rise  $V_T$  for the required horizontal run  $H_T$ .



**The shaded area within the lines represents acceptable values for  $H_T$  and  $V_T$ .**

For vent configurations requiring more than two 90° elbow the following formulas apply:

- Formula 1:  $H_T \leq 3V_T$**
- Formula 2:  $H_T + V_T \leq 40$  feet**

**Example 7:**

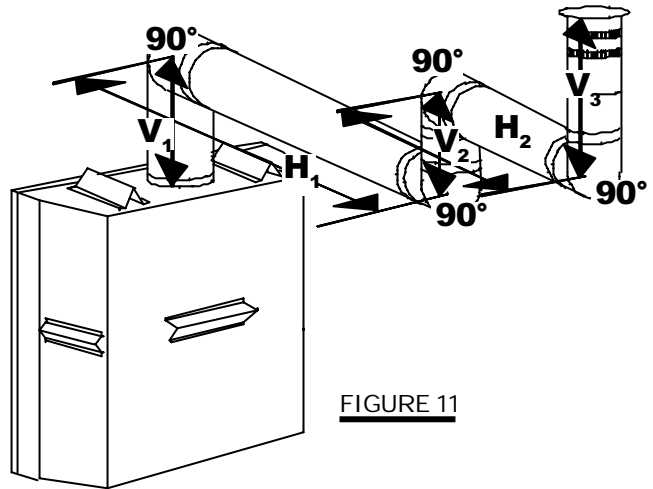

**FIGURE 11**

- $V_1 = 2$  ft
- $V_2 = 1$  ft
- $V_3 = 1.5$  ft
- $V_T = V_1 + V_2 + V_3 = 2 + 1 + 1.5 = 4.5$  ft
- $H_1 = 6$  ft
- $H_2 = 2$  ft
- $H_R = H_1 + H_2 = 6 + 2 = 8$  ft
- $H_o = .03(\text{four } 90^\circ \text{ elbows} - 90^\circ)$   
 $= .03(90 + 90 + 90 + 90 - 90) = 8.1$  ft
- $H_T = H_R + H_o = 8 + 8.1 = 16.1$  ft
- $H_T + V_T = 16.1 + 4.5 = 20.6$  ft

Formula 1:  $H_T \leq 3V_T$   
 $3V_T = 3 \times 4.5 = 13.5$   
 $16.1 > 13.5$

Since this formula is not met, this vent configuration is **unacceptable**.

Formula 2:  $H_T + V_T \leq 40$  feet  
 $20.6 \leq 40$

Since only formula 2 is met, this vent configuration is unacceptable and a new fireplace location or vent configuration will need to be established to satisfy both formulas.

## AIR TERMINAL INSTALLATIONS

**FIGURE 12**

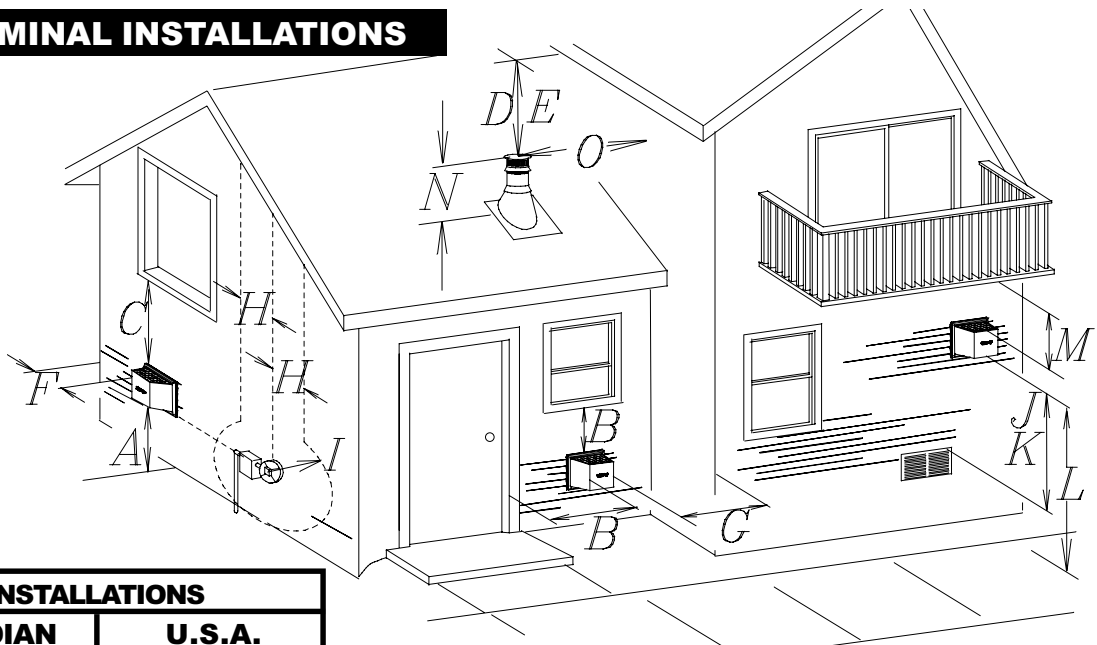

<b>INSTALLATIONS</b>			
	<b>CANADIAN</b>	<b>U.S.A.</b>	
<b>A</b>	<b>12 INCHES</b>	<b>12 INCHES</b>	Clearance above grade, veranda porch, deck or balcony.
<b>B</b>	<b>12 INCHES</b>	<b>9 INCHES</b>	Clearance to windows or doors that open.
<b>C</b>	<b>12 INCHES*</b>	<b>12 INCHES*</b>	Clearance to permanently closed windows.
<b>D</b>	<b>18 INCHES**</b>	<b>18 INCHES**</b>	Vertical clearance to ventilated soffit located above the terminal within a horizontal distance of 2 feet from the centerline of the terminal.
<b>E</b>	<b>12 INCHES**</b>	<b>12 INCHES**</b>	Clearance to unventilated soffit.
<b>F</b>	<b>0 INCHES</b>	<b>0 INCHES</b>	Clearance to an outside corner wall.
<b>G</b>	<b>0 INCHES***</b>	<b>0 INCHES***</b>	Clearance to an inside <i>non</i> -combustible corner wall or protruding <i>non</i> -combustible obstructions (chimney, etc.).
	<b>2 INCHES***</b>	<b>2 INCHES***</b>	Clearance to an inside combustible corner wall or protruding combustible obstructions ( vent chase, etc.).
<b>H</b>	<b>3 FEET</b>	<b>3 FEET****</b>	Clearance to each side of the centerline extended above the meter / regulator assembly to a maximum vertical distance of 15ft.
<b>I</b>	<b>3 FEET</b>	<b>3 FEET****</b>	Clearance to a service regulator vent outlet.
<b>J</b>	<b>12 INCHES</b>	<b>9 INCHES</b>	Clearance to a non-mechanical air supply inlet to the building or a combustion air inlet to any other appliance.
<b>K</b>	<b>6 FEET</b>	<b>3 FEET†</b>	Clearance to a mechanical air supply inlet.
<b>L</b>	<b>7 FEET‡</b>	<b>7 FEET****</b>	Clearance above a paved sidewalk or paved driveway located on public property unless fitted with a heat shield kit GD-301.
<b>M</b>	<b>12 INCHES††</b>	<b>12 INCHES****</b>	Clearance under a veranda, porch, deck or balcony.
<b>N</b>	<b>16 INCHES</b>	<b>16 INCHES</b>	Clearance above the roof.
<b>O</b>	<b>2 FEET†*</b>	<b>2 FEET†*</b>	Clearance from an adjacent wall including neighbouring buildings.

\* Recommended to prevent condensation on windows and thermal breakage

\*\* It is recommended to use a heat shield and to maximize the distance to vinyl clad soffits.

\*\*\* The periscope GD-201 requires a minimum 18 inches clearance from an inside corner.

\*\*\*\* This is a recommended distance. For additional requirements check local codes.

† Three feet above if within 10 feet horizontally.

‡ A vent shall not terminate directly above a sidewalk or paved driveway that is located between two single family dwellings and serves both dwellings.

†† Permitted only if the veranda, porch, or deck is fully open on a minimum of two sides beneath the floor.

†\* Recommended to prevent recirculation of exhaust products. For additional requirements check local codes.

# INSTALLATION

## WALL AND CEILING PROTECTION

For optimum performance it is recommended that all horizontal runs have a minimum  $\frac{1}{4}$  inch rise per foot using flexible venting.

For safe and proper operation of the fireplace, follow the venting instructions exactly.

**HORIZONTAL TERMINATION:** A clearance to combustibles of 2" must be maintained during the first 24" of venting when penetrating combustible walls. The firestop spacer (GD-500.106) supplied with the unit should be used to maintain this clearance. The first two feet of outer 7" diameter vent pipe, from the appliance must be wrapped in the 1 inch thick insulation sleeve (supplied) as well as having a 1 inch air gap. Thereafter a 1" clearance to combustibles may be maintained using firestop spacer (GD-500.96 for use with flexible venting or GD-500.136 for use with rigid venting).

**VERTICAL TERMINATION:** Only a clearance to combustibles of 1" all around the vent pipe is required.

### HORIZONTAL INSTALLATION

#### HORIZONTAL INSTALLATION:

This application occurs when venting through an exterior wall. **FIGURES 2a-d.** Having determined the air terminal location, cut and frame a hole in an exterior wall with a minimum square or round opening of  $11\frac{1}{2}$ "\*. (As an alternative to framing, a vent pipe shield may be installed, ensuring a 1" clearance to combustibles.

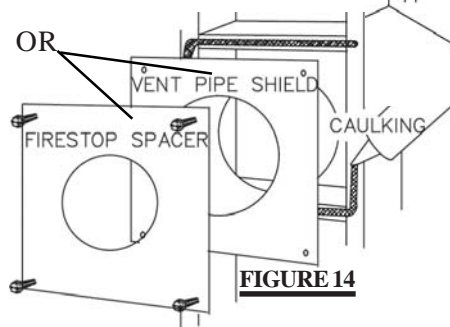

Mark and cut the vent pipe shield to the determined depth of the combustible wall. Apply a bead of caulking (not supplied) to the framework or to the shield plate (in the case of a finished wall) and secure the shield through the opening to the interior wall. The final location of the vent pipe shield should maintain the required clearance to the 7" vent pipe / liner. Do not fill this cavity with any type of material. Apply a bead of caulking all around and place a firestop spacer over the vent shield to restrict cold air from being drawn into the room or around the fireplace. Ensure that both spacer and shield maintain the required clearance to combustibles. Once the vent pipe / liner is installed in its final position, apply sealant between the pipe / liner and the firestop spacer.

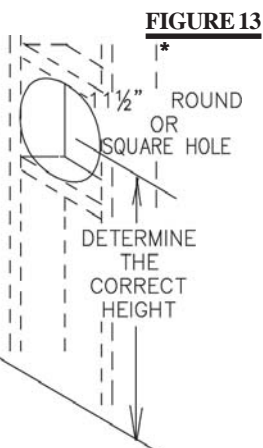

### VERTICAL INSTALLATION

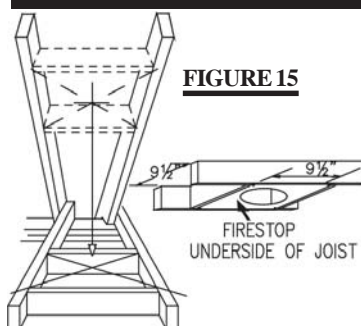

This application occurs when venting through a roof. Installation kits for various roof pitches are available from your Napoleon dealer. See Accessories to order the specific kit required.

1. Determine the air terminal location, cut and frame  $9\frac{1}{2}$  inch openings in the ceiling and the roof to provide the minimum clearance between the fireplace pipe / liner and any combustible material. Try to center the exhaust pipe location midway between two joist to prevent having to cut them. Use a plumb bob to line up the center of the openings.

DO NOT FILL THIS SPACE WITH ANY TYPE OF MATERIAL.

A vent pipe shield will prevent any materials such as insulation, from filling up the 1" air space around the pipe. Nail headers between the joist for extra support.

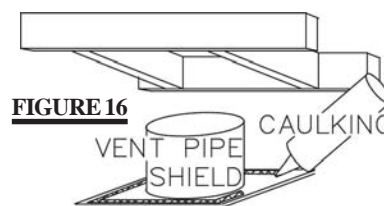

2. Apply a bead of caulking (not supplied) to the framework or to the Wolf Steel vent pipe shield plate or equivalent (in the case of a finished ceiling), and secure over the opening in the ceiling. A firestop must be placed on the bottom of each framed opening in a roof or ceiling that the venting system passes through. Apply a bead of caulking all around and place a firestop spacer over the vent shield to restrict cold air from being drawn into the room or around the fireplace. Ensure that both spacer and shield maintain the required clearance to combustibles. Once the vent pipe / liner is installed in its final position, apply sealant between the pipe / liner and the firestop spacer.

3. In the attic, after the pipe / liner has been installed, slide the vent pipe collar down to cover up the open end of the shield and tighten. This will prevent any materials, such as insulation, from filling up the 1" air space around the pipe.

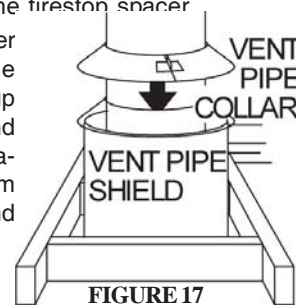

\* The  $11\frac{1}{2}$  inch framing dimension may be reduced to a  $9\frac{1}{2}$  inch opening if the vent length, from the fireplace to the framed hole, is 24 inches or greater. If not, it is recommended to use a terminal extension plate, W500-0103, when mounting the air terminal.

## USING FLEXIBLE VENT COMPONENTS



Use only approved aluminum flexible liner kits marked "Wolf Steel Approved Venting" as identified by the stamp only on the 7" outer liner.

For optimum performance it is recommended that all horizontal runs have a minimum  $\frac{1}{4}$  inch rise per foot using flexible venting.

### HORIZONTAL AIR TERMINAL INSTALLATION

1. Stretch the 4" diameter aluminum flexible liner to the required length taking into account the additional length needed for the finished wall surface. Apply a heavy bead of the high temperature sealant Mill Pac, to the inside of the 4" liner approximately 1" from the end. Slip the liner a minimum of 2" over the fireplace vent collar and secure with 3 #8 screws.

2. Using the 7" diameter flexible aluminum liner, apply sealant, slide a minimum of 2" over the fireplace combustion air collar and secure with 3 #8 screws.

3. Insert the liners through the firestop. Position and secure the fireplace using the nailing tabs (2 per side) and/or secure to the floor using screws inserted through the two  $\frac{1}{4}$ " diameter holes in the front left and right corners of the base. The liners should be flush with the exterior wall.

The air terminal may be recessed into the exterior wall or siding by  $1\frac{1}{2}$ ", the depth of the return flange.

FIGURE 18

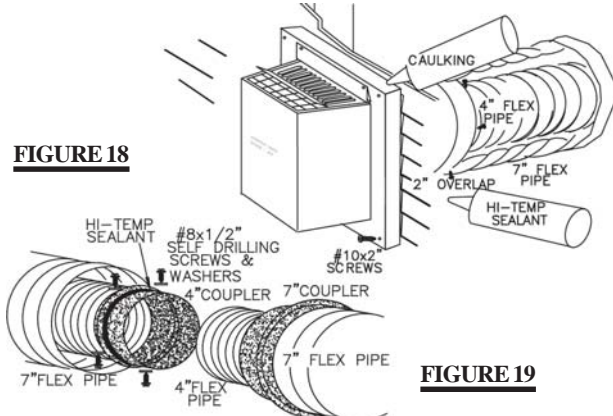

FIGURE 19

4. From outside, apply a bead of the high temperature sealant to the inside of both liners, approximately 1" from the end of each liner.

5. Holding the air terminal (lettering in an upright, readable position), insert into both liners with a twisting motion to ensure that both the terminal sleeves engage into the liners / sealant. Secure the terminal to the exterior wall and make weather tight by sealing with caulking (not supplied).

6. If more liner needs to be used to reach the fireplace, couple them together as illustrated in FIGURE 13. The vent system must be supported approximately every 3 feet for both vertical and horizontal runs. Use Napoleon support ring assembly **W010-0370** or equivalent noncombustible strapping to maintain the minimum 1" clearance to combustibles.

For safe and proper operation of the fireplace, follow the venting instructions exactly.

All inner exhaust and outer intake vent pipe joists may be sealed using either Red RTV high temp silicone sealant or Black high temp Mill Pac with the exception of the fireplace exhaust flue collar which must be sealed using Mill Pac (not supplied).

### VERTICAL AIR TERMINAL INSTALLATION

1. Fasten the roof support to the roof using the screws provided. The roof support is optional. In this case the venting is to be adequately supported using either an alternate method suitable to the authority having jurisdiction or the optional roof support.

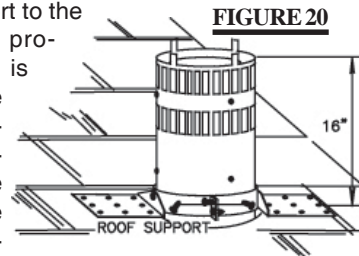

FIGURE 20

2. Stretch the 4" diameter aluminum flexible liner to the required length. Slip the liner a minimum of 2" over the inner sleeve of the air terminal and secure with 3 #8 screws. Seal using a heavy bead of the high temperature sealant.

3. Repeat using 7" diameter aluminum flexible liner.

4. Thread the air terminal pipe assembly down through the roof. The air terminal must be located vertically and plumb. Attach the air terminal assembly to the roof support, ensuring that a minimum 16" of air terminal will penetrate the roof when fastened.

**DO NOT CLAMP THE FLEXIBLE ALUMINUM LINER.**

5. Remove nails from the shingles, above and to the sides of the chimney. Place the flashing over the air terminal and slide it underneath the sides and upper edge of the shingles. Ensure that the air terminal is properly centered within the flashing, giving a  $\frac{3}{4}$ " margin all around. Fasten to the roof. Do **not** nail through the lower portion of the flashing. Make weather-tight by sealing with caulking. Where possible, cover the sides and top edges of the flashing with roofing material.

6. Apply a heavy bead of weatherproof caulking 2 inches above the flashing. Slide the storm collar around the air terminal and down to the caulking. Tighten to ensure that a weather-tight seal between the air terminal and the collar is achieved. Attach the other storm collar centered between the air intake and the air exhaust slots onto the air terminal. Tighten securely. Attach the vertical rain cap.

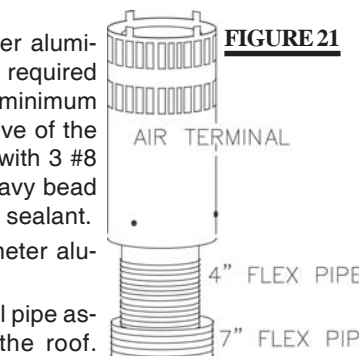

FIGURE 21

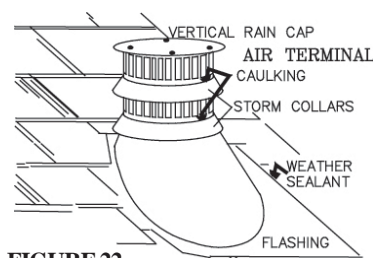

FIGURE 22

Spacers are attached to the 4" inner flex liner at predetermined intervals to maintain a 1-1/4" air gap to the 7" outer liner. These spacers must not be removed.

7. If more liner needs to be used to reach the fireplace, couple them together as illustrated in **FIGURE 13**. The vent system must be supported approximately every 3 feet for both vertical and horizontal runs. Use Wolf Steel support ring assembly **W010-0370** or equivalent noncombustible strapping to maintain a clearance to combustibles of 1".

## FIREPLACE VENT CONNECTION

1. Install the 4 inch diameter aluminum flexible liner to the fireplace. Secure with 3 screws and flat washers. Seal the joint and screw holes using the high temperature sealant Mill Pac.

2. Install the 7 inch diameter aluminum flexible liner to the fireplace. Attach and seal the joints.

**FIGURE 23**

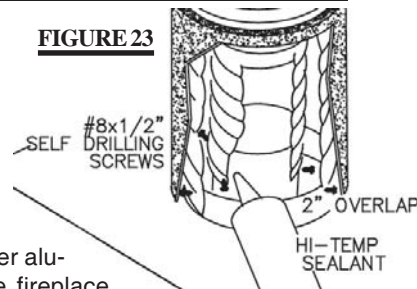

## USING RIGID VENT COMPONENTS

*For optimum performance it is recommended that all horizontal runs have a 1/4 inch rise per foot.*

*For safe and proper operation of the fireplace, follow the venting instructions exactly.*

The vent system must be supported approximately every 3 feet for both vertical and horizontal runs. Use Napoleon vent spacers **W615-0033** every 3 feet and on either side of each elbow to maintain the minimum 1 1/4" clearance between the outer and inner vent pipes. Use Napoleon support ring assembly **W010-0370** or equivalent noncombustible strapping to maintain the minimum 1" clearance to combustibles for both vertical and horizontal runs.

*All inner exhaust and outer intake vent pipe joists may be sealed using either Red RTV high temp silicone sealant or Black high temp Mill Pac with the exception of the fireplace exhaust flue collar which must be sealed using Mill Pac (not supplied).*

### HORIZONTAL AIR TERMINAL INSTALLATION

1. Move the fireplace into position. Measure the vent length required between terminal and fireplace taking into account the additional length needed for the finished wall surface and any 1 1/4" overlaps between venting components.

2. Apply high temperature sealant Mill Pac to the outer edge of the 4" inner collar of the fireplace. Attach the first vent component and secure using 3 self tapping screws. Repeat using 7" piping.

3. Holding the air terminal (lettering in an upright, readable position), insert into both vent pipes with a twisting motion to ensure that both the terminal sleeves engage into the vent pipes and the sealant. Secure the terminal to the exterior wall and make weather tight by sealing with caulking (not supplied). **The air terminal may be recessed into the exterior wall or siding by 1 1/2", the depth of the return flange.**

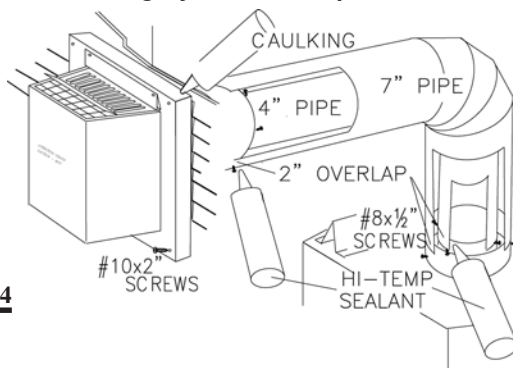

**FIGURE 24**

### VERTICAL VENTING INSTALLATION

1. Move the fireplace into position.

2. Fasten the roof support to the roof using the screws provided. **FIGURE 16**. The roof support is optional. In this case the venting is to be adequately supported using either an alternate method suitable to the authority having jurisdiction or the optional roof support.

3. Apply high temperature sealant to the outer edge of the inner sleeve of the air terminal. Slip a 4" diameter coupler a minimum of 2" over the sleeve and secure using 3 screws.

4. Apply high temperature sealant to the outer edge of the outside sleeve of the air terminal. Slip a 7" diameter coupler over the sleeve and secure as before. **FIGURE 19**. Trim the 7" coupler even with the 4" coupler end.

5. Thread the air terminal pipe assembly down through the roof support and attach, ensuring that a minimum 16" of air terminal will penetrate the roof when fastened. **FIGURE 18**. **If the attic space is tight, we recommend threading the Wolf Steel vent pipe collar or equivalent loosely onto the air terminal assembly as it is passed through the attic.** The air terminal must be located vertically and plumb.

6. Remove nails from the shingles, above and to the sides of the chimney. Place the flashing over the air terminal and slide it underneath the sides and upper edge of the shingles. Ensure that the air terminal is properly centered within the flashing, giving a 3/4" margin all around. Fasten to the roof. Do NOT nail through the lower portion of the flashing. Make weather-tight by sealing with caulking. Where possible, cover the sides and top edges of the flashing with roofing material.

7. Apply a heavy bead of waterproof caulking 2 inches above the flashing. Slide the storm collar around the air terminal and down to the caulking. Tighten to ensure that a weather-tight seal between the air terminal and the collar is achieved. Attach the other storm collar centered between the air intake and air exhaust slots onto the air terminal. Tighten securely. Attach the rain cap.

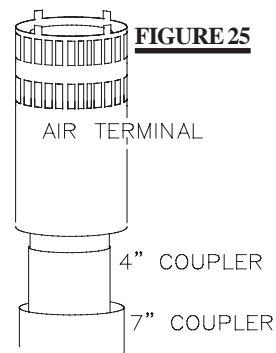

**FIGURE 25**

8. Continue adding rigid venting sections, sealing and securing as above. Attach a 4" collapsed telescopic pipe to the last section of rigid piping. Secure with screws and seal. Repeat using a 7" telescopic pipe.

9. Run a bead of high temperature sealant around the outside of the 4" elbow. Pull the adjustable pipe a minimum 2" onto the elbow. Secure with 3 screws. Repeat with the 7" telescopic pipe.

10. In the attic, slide the vent pipe collar down to cover up the open end of the shield and tighten. This will prevent any materials, such as insulation, from filling up the 1" air space around the pipe.

**RESTRICTING VERTICAL VENTS**

Vertical terminations may display a very active flame. If this appearance is not desirable, the vent exit must be restricted using restrictor supplied. This reduces the velocity of the exhaust gases, slowing down the flame pattern and creating a more traditional appearance.

1. Remove all obstructing obstacles i.e.: brick panels, logs, etc.
2. Remove the baffle plate from the rear wall of the firebox, exposing the two screws from the flue pipe assembly.

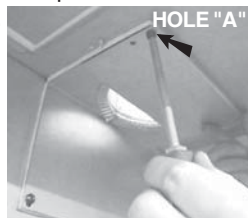

3. Line up the "A" holes on the restrictor plate with the pipe assembly holes and replace the screws.
4. Replace brick panels, logs, etc.

**GAS INSTALLATION**

*Proceed once the vent installation is complete.*

1. Route a 3/8" N.P.T. black iron gas line, 1/2" type-L copper tubing or equivalent to the fireplace.

2. For ease of accessibility, an optional remote wall switch or millivolt thermostat may be installed in a convenient location. Route 2 strand (solid core) millivolt wire through the electrical hole located at the bottom left side of the unit. The recommended maximum lead length depends on wire size:

WIRE SIZE	MAX. LENGTH
14 gauge	100 feet
16 gauge	60 feet
18 gauge	40 feet

Attach the two leads to terminals 1 and 3 located on the gas valve.

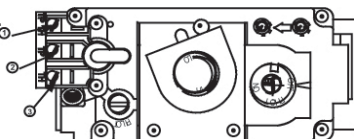

FIGURE 26

**Do not connect either the wall switch, thermostat or gas valve to electricity (110 volts).**

3. Install rigid black pipe, 1/2" type-L copper tubing or, if local codes permit, a 3/8" flex connector and shutoff valve to the gas line and the fireplace gas valve. Seal and tighten securely. An adaptor fitting is required between the gas valve and the copper tubing or flex connector. **DO NOT KINK THE FLEXIBLE CONNECTOR.**

4. Check for gas leaks by brushing on a soap and water solution. **DO NOT USE OPEN FLAME.**

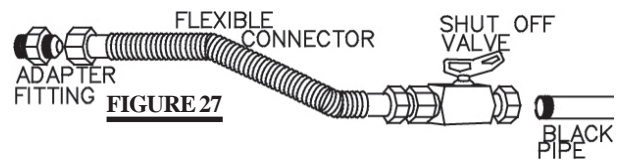

FIGURE 27

**Purge all gas lines with the glass door of the fireplace open. Assure that a continuous gas flow is at the burner before closing the door.**

**MOBILE HOME INSTALLATION**

The fireplace is equipped with two 1/4" diameter holes located in the front left and right corners of the base. For mobile home installations, the fireplace must be fastened in place. Use #10 screws, inserted through the holes in the base to secure. It is recommended that the fireplace be secured in all installations.

**FRAMING**

**Note:** In order to avoid the possibility of exposed insulation or vapour barrier coming in contact with the fireplace body, it is recommended that the walls of the fireplace enclosure be "finished" (ie: drywall/ sheetrock), as you would finish any other outside wall of a home. This will ensure that clearance to combustibles is maintained within the cavity.

It is not necessary to install a hearth extension, but the fireplace should be raised up to be flush with either the hearth or the finished floor.

When roughing in the fireplace, raise the fireplace to accommodate for the thickness of the finished floor materials, i.e. tile, carpeting, hard wood, which if not planned for will interfere with the opening of the lower access door and the installation of many decorative flashing accessories.

Objects placed in front of the fireplace should be kept a minimum of 48" away from the front face.

**PROTRUDING FINISH**

Non-combustible material (brick, stone or ceramic tile) may protrude over the black painted surface of the fireplace front and is required for use in conjunction with the GD425 kit. This kit is designed to accommodate a noncombustible material to a maximum finished thickness of 3/4".

**\*When using the optional ornamental facia and panels, the minimum height from the top of the unit to the mantle is 7".**

**\*\*A steel stud header is recommended, however traditional combustible header material may be used.**

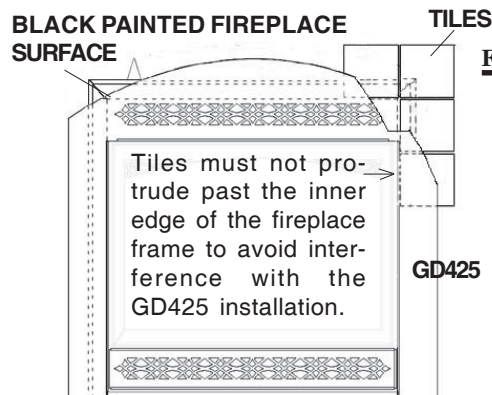

FIGURE 33

**EXAMPLE A - NON-COMBUSTIBLE MATERIAL**

It is best to frame your fireplace after it is positioned and the vent system is installed. Use 2x4's and frame to local building codes. To install the fireplace face flush with the finished wall, position the framework to accommodate the thickness of the finished wall.

**MAINTAIN THESE MINIMUM CLEARANCES TO COMBUSTIBLES:**

Fireplace framing - 0" to stand-offs (top, rear & sides)  
 Fireplace finishing - 3" to sides, 7 1/4" to top of unit

**FIGURE 28**

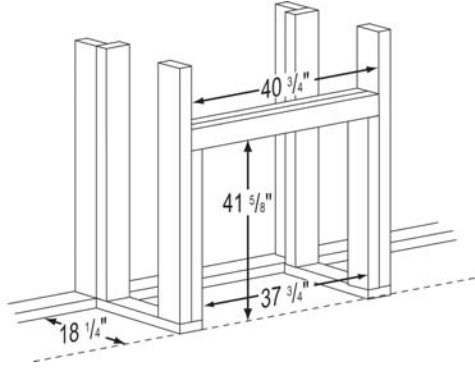

**FIGURE 29**

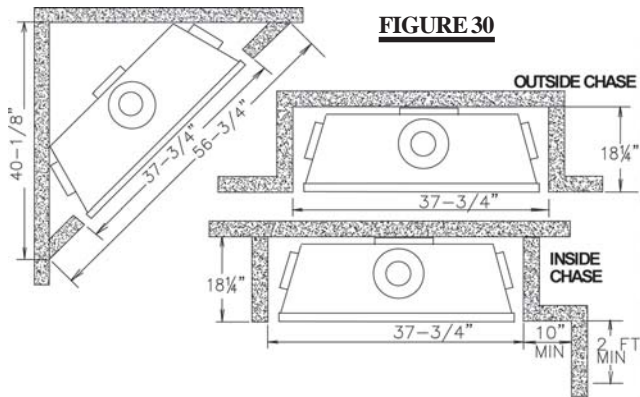
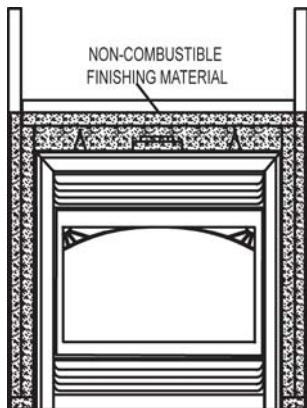

**FIGURE 30**

**FLUSH FINISH**

To install the fireplace face flush with the finished wall, position the framework to accommodate the thickness of the finished wall.

**FIGURE 31**



**FIGURE 32**

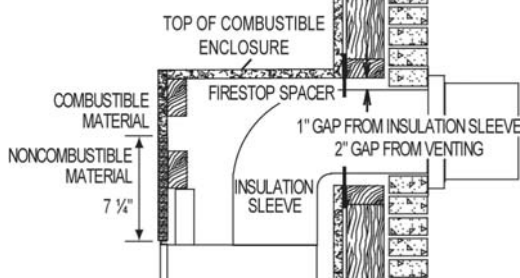

**EXAMPLE B - BEVELLED TRIM**

The non-combustible finishing material may be eliminated if the intent is to finish the unit with the optional 6" bevelled trim.

**FIGURE 34**

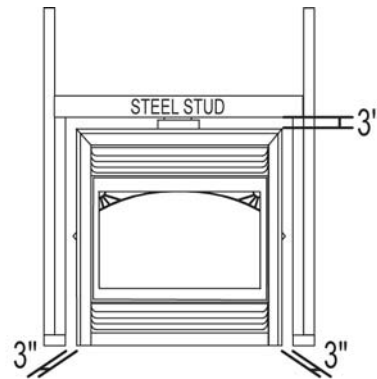
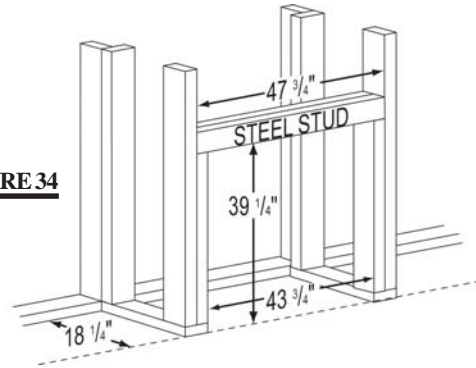

**FIGURE 35**

**FIGURE 36**

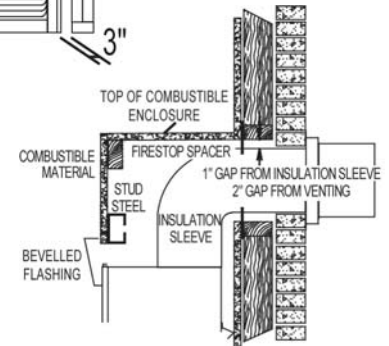

**MANTLE CLEARANCES**

Combustible mantle clearance can vary according to the mantle depth. Use the graph to help evaluate the clearance needed.

**FIGURE 37**

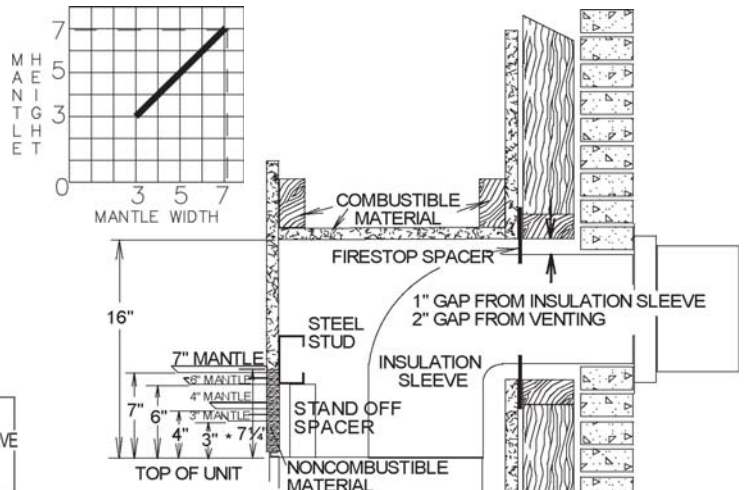

# FINISHING

## DOOR INSTALLATION

Loosely thread a screw provided with the door kit into the top hole on the left side of the firebox. Hang the door by the hinge onto the screw. Insert the remaining 4 screws and tighten.

**IMPORTANT:** Ensure screws are driven in straight or the hole thread may be damaged.

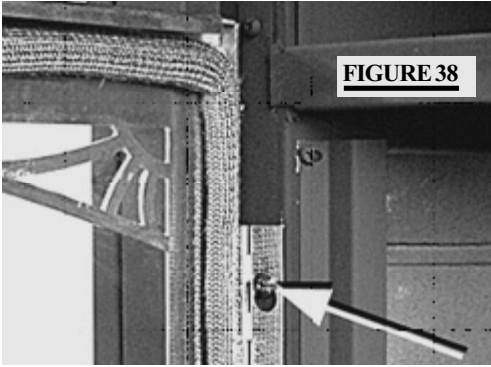

**FIGURE 38**

## DOOR CLOSING AND OPENING

Open the valve control door. Hook the top and bottom door latches, located at the right side of the door into the corresponding slots in the door.



**FIGURE 39**

**The door latch holes are elongated for door levelling. To level the door, it may need to be lifted up at the right side before latching to ensure the door is level.**

Prior to opening the door, lift up and remove the upper louvres or ornamental insets.

## GDLV LOUVRE INSTALLATION

Remove the protective plastic wrap from the louvres and install as illustrated.

Clip each upper louvre into a slot on the louvre bracket. Ensure that the louvres are centered within the opening.

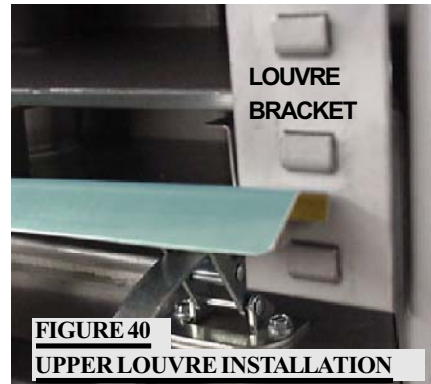

**FIGURE 40**  
**UPPER LOUVRE INSTALLATION**

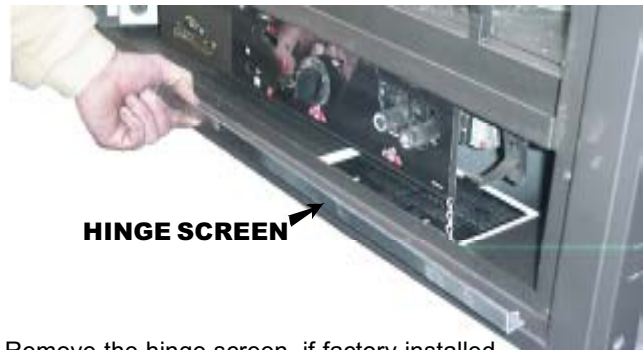

**HINGE SCREEN**

Remove the hinge screen, if factory installed.

**FIGURE 41**

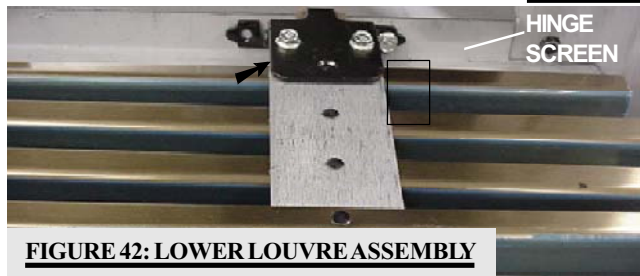

**FIGURE 42: LOWER LOUVRE ASSEMBLY**

Screw the lower louvre assembly to the lip of the fireplace base as shown. Position the hinge screen into place and with the control door open, secure to the firebox using three screws.



## L38 LOUVRE INSTALLATION

FIGURE 43 a-c

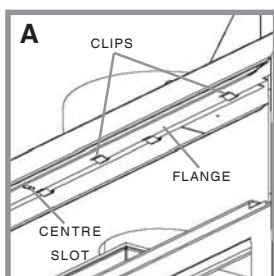
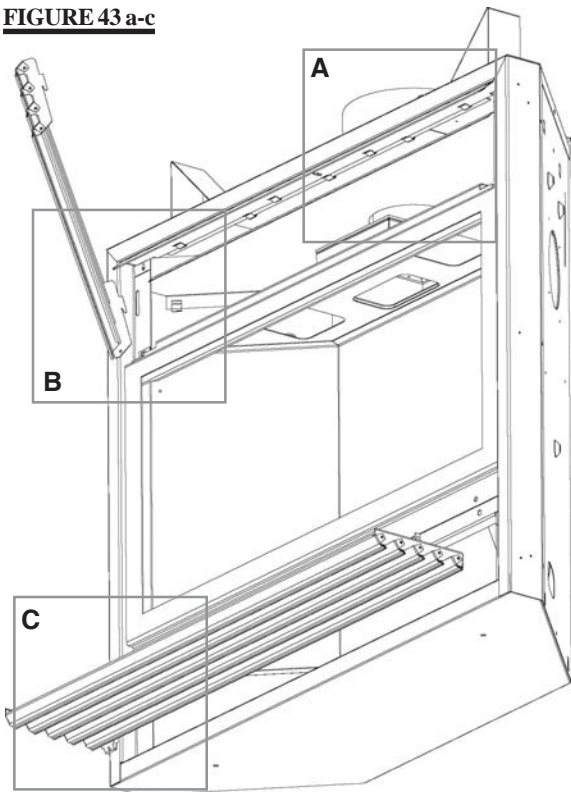

### HOOD

Attach the hood by pressing the top flange into the clips along the top of the louvre opening. Secure using a screw through the centre slot.

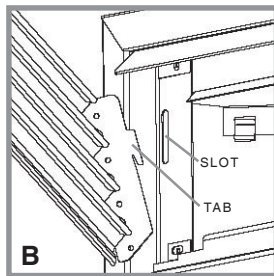

### UPPER LOUVRES

Insert the louvre tabs into the slots located at the top left and right corners of the unit.

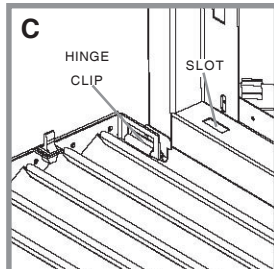

### LOWER LOUVRES

Insert the hinge clips into the slots located at the bottom left and right corners of the unit.

To remove the louvres, pull the back tabs of the clips forward, while pushing the louvre assembly back. Lift the clip.

## LOG SHIPPING BRACKET

FIGURE 45



Before installing the logs, you must first remove the log shipping bracket. Loosen the securing screw indicated. Slide the bracket to the right and lift up to remove.

## DECORATIVE PANELS

This fireplace does not include decorative brick panels, however, panels are required.

You now have the option of choosing 1 of 4 panel kits **SOLD SEPARATELY**. (See Accessories).

## CHARCOAL STRIPS

The charcoal strips have been shipped in place. Protective foam must be removed before operation.

**LOG PLACEMENT**

PHAZER™ logs, exclusive to Napoleon Fireplaces, provide a unique and realistic glowing effect that is different in every installation. **FIGURES 46a-e**

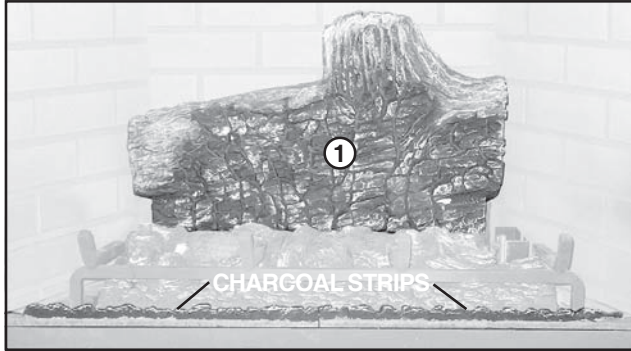

**1.** Centre the two charcoal strips, as shown, along the inside front edge of the firebox. Place the rear log #1 onto the locating studs along the back edge of the PHAZERAMIC™ burner.

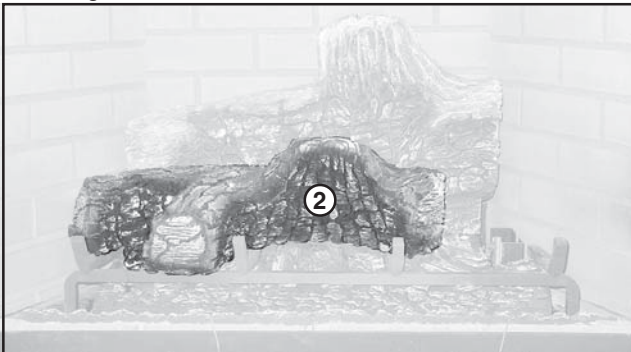

**2.** Position log #2 onto the locators on the PHAZERAMIC™ burner.

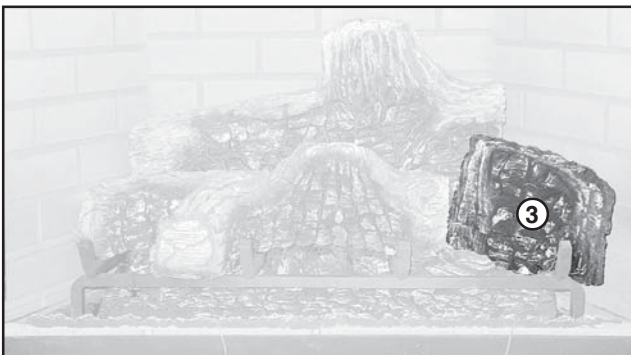

**3.** Position log #3 onto the right most grate rail with the charred face to the front. Align the groove on the underside of the log, with the rail of the grate. Push the log back to the pilot housing. Log #3 should fit tight against log #2.

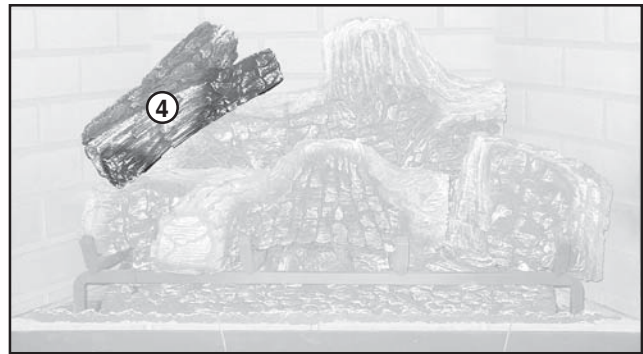

**4.** Place log #4, with the charred branch pointed inward. Locate the pins into the holes in log#1 and log#2, this will hold the rear log in position.

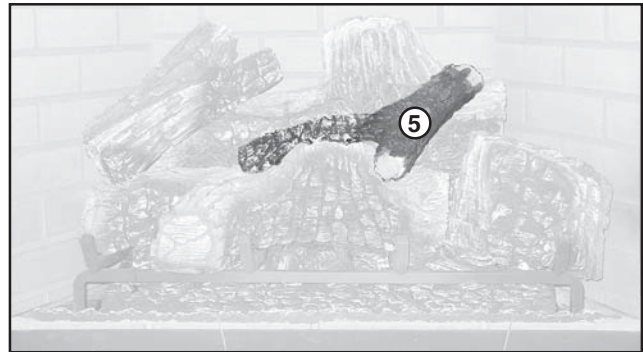

**5.** Place the end of log #5 on the right end of log #1. The fork in the log should straddle the knot on top of log #2.

**GLOWING EMBERS**

Glowing embers (not supplied) maybe used to enhance the flame's appearance.

**BAFFLE INSTALLATION**

Your fireplace has been supplied with the decorative brick panels installed. It will be necessary, however, to install the fibre baffle, on top of the side and rear panels.

**CHARCOAL EMBERS**

Charcoal provided should be randomly placed in the triangular trays on either side of the of the burner.

**Log colours may vary. During the initial use of the fireplace, the colours will become more uniform as colour pigments burn in during the heat activated curing process.**

**Positioning the logs improperly will cause flame impingement and carboning.**

Blocked burner ports can cause an incorrect flame pattern, carbon deposits and delayed ignition. **PHAZER™** logs glow when exposed to direct flame. Use only certified **PHAZER™** logs available from your Napoleon dealer.

## ACCENT LITE REPLACEMENT

Your Napoleon STARfire comes equipped with our “Accent Lite”. The light has been pre-wired and can be controlled from the switch on the control panel.

***It is recommended that the ACCENT LITE be in the off position when the fireplace is on.***

If in the event the lamp or lens needs to be replaced, follow the instructions below.

Unplug the light from inside the fireplace.



**FIGURE 47**

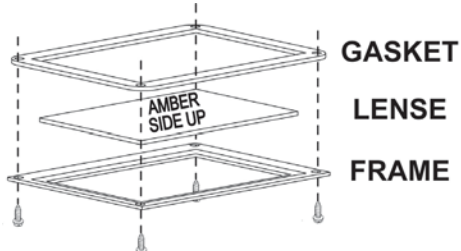

**FIGURE 48**

Remove the four screws that secure the lens frame.

This frame retains the glass lens. The lamp can now be accessed.

**FIGURE 49**



***Note: Do not handle the lamp (bulb) with bare fingers, protect with a clean dry cloth.***

The lamp will pull straight out of the socket. Replace with Wolf Steel parts only, as lamp and lens are special “high temperature” products.

When re-installing, ensure integrity of gasket seal.

***THE FIREBOX MUST BE SEALED.***

***Over tightening the screws could break the lens.***

***“Light Leakage” from the upper louvre area may be noticed. The holes in the lamp housing are necessary for ventilation and must not be covered.***

## IN LINE SWITCH

The FIRE LOG ACCENT LIGHT is provided with a manual “in-line” switch to turn the light on and off. There are alternate methods of operating the light.

An example of one method would be to “hard-wire” a wall switch. The switch could be installed in desired location to operate the FIRE LOG ACCENT LIGHT plugged into one of the two receptacles on the fireplace junction box. The other receptacle would still have power to operate other accessories (see schematic below).

This switch could be:

- Toggle
- Photo cell
- Remote
- Motion Sensor

All switches are available at your building store.

**NOTE**

***ELECTRICAL INSTALLATION TO BE DONE BY A QUALIFIED INSTALLER and must be connected and grounded in accordance with local codes.***

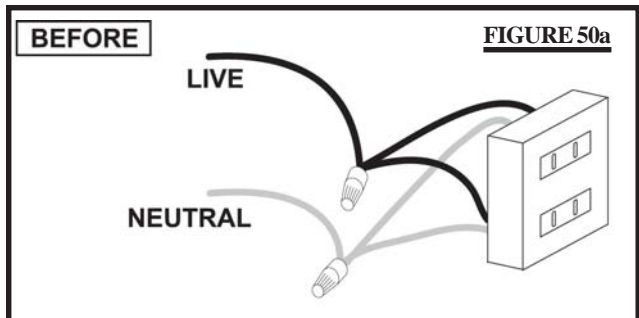

**FIGURE 50a**

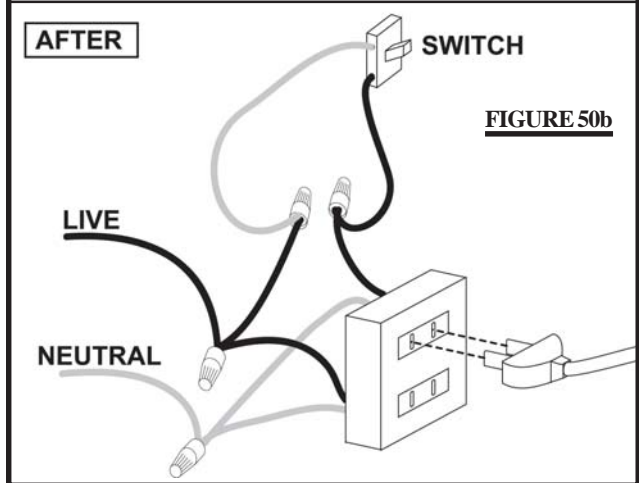
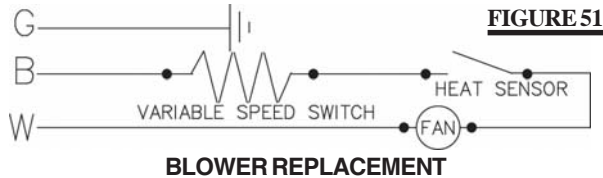

**FIGURE 50b**

## BLOWER INSTALLATION

### BLOWER SYSTEM

The Napoleon STARfire comes equipped with a blower, a heat sensor, variable on/off speed control and a power cord. The blower is thermally activated, so when it is turned on, it will automatically start approximately 15 minutes after lighting the fireplace and will run for approximately 30 minutes after the fireplace has been turned off. Use of the fan increases the output of heat. Air, drawn in through the lower louver access door, is driven up the back of the firebox, and exhausted as hot air between the upper louvers.



1. Open the lower control area.
2. Remove the control panel (3 screws).
3. Unplug the blower from the junction box or turn off the power to the fireplace if hardwired.

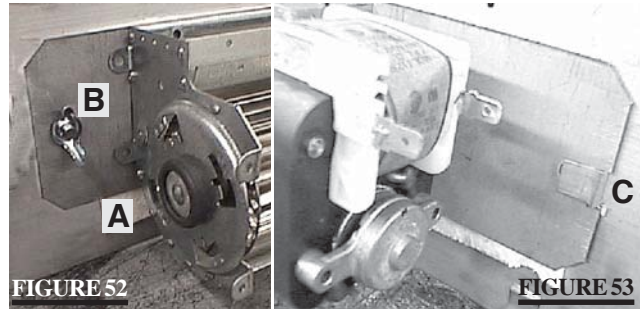

4. Undo the fastener at the left side of the blower mounting plate. The blower should now slide to the left, away from the mounting tab.

5. Finally, disconnect the slip-on connectors at the motor of the blower.

***The wire harness provided in this kit is a universal harness. When installed, ensure that any excess wire is contained, preventing it from making contact with any moving or hot objects.***

***Drywall dust will penetrate into the blower bearings, causing irreparable damage. Care must be taken to prevent drywall dust from coming into contact with the blower or its compartment. Any damage resulting from this condition is not covered by the warranty policy.***

## THERMODISC REPLACEMENT

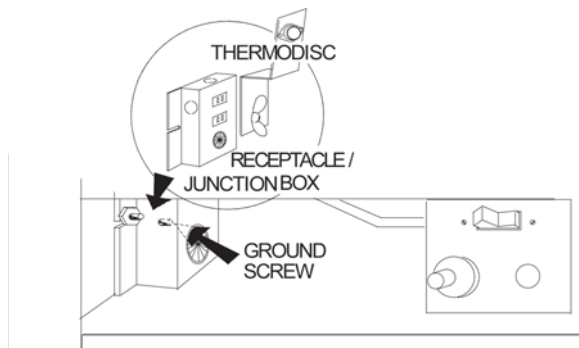

The thermodisc is located to the left side of the lower control area, on a bracket and mounted beside the junction box.

1. Unplug the blower from the junction box or turn off the power to the fireplace if hardwired.
2. Remove the fastener. Pivot the bracket out from the firebox side.
3. Disconnect the slip-on connectors and remove the thermodisc from the bracket.

# OPERATION / MAINTENANCE

## OPERATING INSTRUCTIONS

When lit for the first time, the fireplace will emit a slight odour for a few hours. This is a normal temporary condition caused by the curing of the logs and the "burn-in" of internal paints and lubricants used in the manufacturing process and will not occur again. Simply open a window to sufficiently ventilate the room.

After extended periods of non-operation such as following a vacation or a warm weather season, the fireplace may emit a slight odour for a few hours. This is caused by dust particles in the heat exchanger burning off. Open a window to sufficiently ventilate the room.

**PURGE ALL GAS LINES WITH THE GLASS DOOR OF THE FIREPLACE OPEN. ASSURE THAT A CONTINUOUS GAS FLOW IS AT THE BURNER BEFORE CLOSING THE DOOR.**

### FOR YOUR SAFETY READ BEFORE LIGHTING:

- A.** This fireplace is equipped with a pilot which must be lit by hand while following these instructions exactly.
- B.** Before operating smell all around the fireplace area for gas and next to the floor because some gas is heavier than air and will settle on the floor.
- C.** Use only your hand to turn the gas control knob. Never use tools. If the knob will not turn by hand, do not try to repair it. Call a qualified service technician. Force or attempted repair may result in a fire or explosion.
- D.** Do not use this fireplace if any part has been under water. Immediately call a qualified service technician to inspect the fireplace and replace any part of the control system and any gas control which has been under water.

### WHAT TO DO IF YOU SMELL GAS

- Turn off all gas to the fireplace.
- Open windows.
- Do not try to light any appliance.
- Do not touch any electric switch; do not use any phone in your building.
- Immediately call your gas supplier from a neighbour's phone. Follow the gas supplier's instructions.
- If you cannot reach your gas supplier, call the fire department.

**FIGURE 55**





### LIGHTING INSTRUCTIONS

**WARNING:** The gas valve has an interlock device which will not allow the pilot burner to be lit until the thermocouple has cooled. Allow approximately 60 seconds for the thermocouple to cool.

When lighting and re-lighting, the gas knob cannot be turned from pilot to off unless the knob is **depressed slightly**.



1. Stop! Read the above safety information on this label.
2. Turn off all electric power to the fireplace.
3. Turn the gas knob clockwise  to off.
4. Wait five (5) minutes to clear out any gas. If you smell gas including near the floor. Stop! Follow "B" in the above safety information on this label. If you don't smell gas go the next step.

5. Turn gas knob counter-clockwise  to pilot.
6. Depress slightly and hold gas knob while lighting the pilot with the push button ignitor. Keep knob depressed for one minute, then release. If pilot does not continue to burn, repeat steps 3 through 5.
7. With pilot lit, depress and turn gas knob counter-clockwise  to on.
8. If equipped with remote on-off switch/thermostat, main burner may not come on when you turn valve to on. Remote switch must be in the on position to ignite burner.
9. Turn on all electric power to the fireplace.

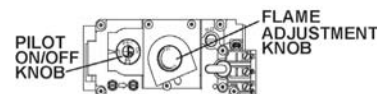
**FIGURE 56**



### TO TURN OFF GAS

1. Turn off all electric power to the fireplace if service is to be performed.
2. For a complete shut-down procedure: push in gas control knob slightly and turn clockwise  to off. Do not force.
3. For a temporary shut-down procedure: set thermostat to lowest setting or remote switch to off. Press and turn the gas knob clockwise  to pilot.

## MAINTENANCE

### TURN OFF THE GAS AND ELECTRICAL POWER BEFORE SERVICING THE FIREPLACE.

**CAUTION:** Label all wires prior to disconnection when servicing controls. Wiring errors can cause improper and dangerous operation. Verify proper operation after servicing. This fireplace and its venting system should be inspected before use and at least annually by a qualified service person. The fireplace area must be kept clear and free of combustible materials, gasoline or other flammable vapours and liquids. The flow of combustion and ventilation air must not be obstructed.

1. In order to properly clean the burner and pilot assembly, remove the logs to expose both assemblies.
2. Keep the control compartment, logs, burner, air shutter opening and the area surrounding the logs clean by vacuuming or brushing, *at least once a year*.

3. Check to see that all burner ports are burning. Clean out any of the ports which may not be burning or are not burning properly.
4. Check to see that the pilot flame is large enough to engulf the thermocouple and thermopile and reaches toward the burner with the third jet.
5. Replace the cleaned logs.
6. Check to see that the main burner ignites completely on all openings when the gas knob for the burner is turned on. A 5 to 10 second total light-up period is satisfactory. If ignition takes longer, consult your Napoleon dealer / distributor.
7. Check that the gasketing on the sides, top and bottom of the door is not broken or missing. Replace if necessary.

## ADJUSTMENTS

### PILOT BURNER ADJUSTMENT

Adjust the pilot screw to provide properly sized flame. Turn in a clockwise direction to reduce the gas flow.

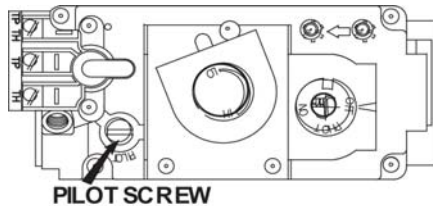

**FIGURE 57**

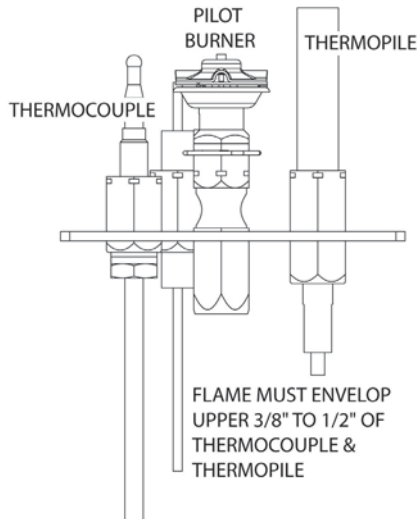
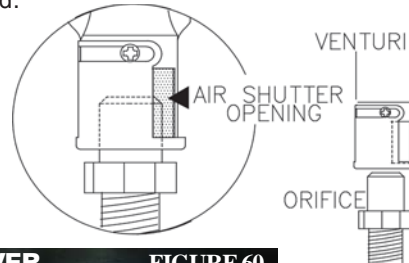

**FIGURE 58**

### VENTURI ADJUSTMENT

Air Shutter Openings	
LP	$\frac{1}{2}$ "
NG	$\frac{1}{4}$ "

Closing the air shutter will cause a more yellow flame, but can lead to carboning. Opening the air shutter will cause a more blue flame, but can cause flame lifting from the burner ports. The flame may not appear yellow immediately; allow 15 to 30 minutes for the final flame colour to be established.



**FIGURE 59**



**COVER** **FIGURE 60**

**AIR SHUTTER ADJUSTMENT MUST ONLY BE DONE BY A QUALIFIED GAS INSTALLER!**

To access the air shutter, remove the two screws that secure the cover to the air housing, taking care not to damage the gasket.

The air shutter on this GD70 STARfire has been set for the longest horizontal vent length possible - 20 ft. **Failure to adjust the air shutter on shorter vent runs will result in a much smaller than intended flame appearance.** The air shutter opening may be adjusted to as little as 1/4" (for propane models) depending on length and configuration. Please refer to the installation manual for adjustment procedure.

# REPLACEMENTS

Contact your dealer for questions concerning prices and availability of replacement parts. Normally all parts can be ordered through your Napoleon dealer or distributor.

When ordering replacement parts always give the following information:

**FOR WARRANTY REPLACEMENT PARTS, A PHOTOCOPY OF THE ORIGINAL INVOICE WILL BE REQUIRED TO HONOUR THE CLAIM.**

1. MODEL & SERIAL NUMBER OF FIREPLACE

2. INSTALLATION DATE OF FIREPLACE

3. PART NUMBER

4. DESCRIPTION OF PART

5. FINISH

*\* IDENTIFIES ITEMS WHICH ARE NOT ILLUSTRATED. FOR FURTHER INFORMATION, CONTACT YOUR NAPOLEON DEALER.*

## REPLACEMENT PARTS

#	PART NO.	DESCRIPTION
1	W135-0205	#1 - REAR LOG
2	W135-0206	#2 - MIDDLE LOG
3	W135-0207	#3 - RIGHT LOG
4	W135-0208	#4 - LEFT LOG
5	W135-0218	#5 - CROSSOVER LOG
6	GL-644	LOG SET ASSEMBLY
7*	W090-0095	L CHARCOAL STRIP
8*	W090-0096	R CHARCOAL STRIP
9*	W390-0002	DOOR LATCH (EA)
10	W725-0025	NATURAL GAS VALVE
10	W725-0026	PROPANE GAS VALVE
11*	W380-0010	PILOT ON/OFF KNOB EXTENSION
12*	W380-0011	FLAME ADJUSTMENT KNOB EXTENSION
13	W455-0058	#35 NATURAL GAS ORIFICE
13	W455-0051	#51 PROPANE GAS ORIFICE
14	W357-0001	PIEZO IGNITER
15	W680-0005	THERMOCOUPLE
16	W240-0005	ELECTRODE c/w LEAD
17	W680-0004	THERMOPILE
18	W010-0801	NATURAL GAS PILOT ASSEMBLY
18	W010-0800	PROPANE GAS PILOT ASSEMBLY
19	W455-0070	NG PILOT INJECTOR
19	W455-0068	LP PILOT INJECTOR
20*	W385-0245	NAPOLEON LOGO
21*	W361-0027	INSULATION SLEEVE
22*	W010-0621	GLASS c/w GASKET
23*	W562-0009	DOOR GASKET (100 INCHES)
24*	W500-0106	FIRESTOP (2 INCH CLEARANCE)
25	W010-1135	BURNER ASSEMBLY
26*	W200-0146	COVER PLATE
27*	W290-0080	COVER PLATE GASKET
28	W062-0005	BLOWER
29	W690-0002	THERMODISC
30*	W750-0050	BLOWER WIRE
31*	W660-0019	VARIABLE SPEED SWITCH
32*	W300-0067	FIRE LOG ACCENT LIGHT GLASS
33*	W387-0006	ACCENT LAMP
34*	W750-0107	FIRE LOG ACCENT LIGHT WIRE
35*	W290-0080	ACCENT LENSE GASKET
36*	W500-0130	RESTRICTOR PLATE

## ROOF TERMINAL KITS

### GD-110 - ROOF TERMINAL KIT - 1/12 TO 7/12 PITCH

37	W120-0036	VERTICAL CAP
38	W010-0569	AIR TERMINAL
39	W010-0567	ROOF SUPPORT
40	W170-0063	STORM COLLAR
41	W263-0054	ROOF FLASHING

### GD-111 - ROOF TERMINAL KIT - 8/12 TO 12/12 PITCH

37	W120-0036	VERTICAL CAP
38	W010-0569	AIR TERMINAL
39	W010-0567	ROOF SUPPORT
40	W170-0063	STORM COLLAR
41	W263-0055	ROOF FLASHING

### GD-112 - ROOF TERMINAL KIT - FLAT ROOF

37	W120-0036	VERTICAL CAP
38	W010-0569	AIR TERMINAL
39	W010-0567	ROOF SUPPORT
40	W170-0063	STORM COLLAR
41	W263-0056	ROOF FLASHING

## TERMINAL KITS

42 **GD-201 - PERISCOPE**

43 **GD-222 - WALL TERMINAL KIT**

## VENT KITS

### GD-220 (5 FOOT)

44	W010-0397	4" FLEXIBLE ALUMINUM LINER c/w SPACERS
45	W410-0017	7" FLEXIBLE ALUMINUM LINER

44	W010-0300	4" FLEXIBLE ALUMINUM LINER c/w SPACERS
45	W410-0018	7" FLEXIBLE ALUMINUM LINER
52	W010-0370	WALL SUPPORT ASSEMBLY

## ACCESSORIES

#	PART NO.	DESCRIPTION
46	W615-00044	FIRE STOP - FLEXIBLE VENTING
46	W500-0136	FIRESTOP - RIGID VENTING
47	W500-0103	TERMINAL EXTENSION PLATE
48*	W573-0008	HI-TEMP SEALANT
49	GD101	WINDSHIELD KIT
50	GD301	HEAT GUARD
51	GA-566	HOT AIR DISTRIBUTION KIT
52	GA-72	HOT AIR EXHAUST KIT
53	GA-70	EXTENSION KIT, 5FT FLEX VENT
54*	W010-0370	WALL SUPPORT ASSEMBLY
55*	W175-0001	4" COUPLER
56*	W175-0013	7" COUPLER
57*	W175-0221	CONVERSION KIT - NG TO LP
57*	W175-0222	CONVERSION KIT - LP TO NG
58*	GD825-N	MODULATING REGULATOR NG
58*	GD825-P	MODULATING REGULATOR LP
59	GDLVPB	UPPER & LOWER LOUVRE KIT - POLISHED BRASS
59	GDLVSS	UPPER & LOWER LOUVRE KIT - STAINLESS STEEL
59	GDLVK	UPPER & LOWER LOUVRE KIT - BLACK
59	GDLVG	UPPER & LOWER LOUVRE KIT - GOLD
60	L38K	LOUVRE KIT - UPPER & LOWER - BLACK
60	L38AB	LOUVRE KIT - UPPER & LOWER - ANTIQUE BRASS
60	L38PB	LOUVRE KIT - UPPER & LOWER - POLISHED BRASS
60	L38SS	LOUVRE KIT - UPPER & LOWER - STAINLESS STEEL
61	KB35	VARIABLE SPEED SWITCH
62*	W500-0033	V.S.S. MOUNTING PLATE FOR WALL SWITCH
63*	W690-0001	MILLIVOLT THERMOSTAT
64*	W690-0005	110 VOLT THERMOSTAT - FOR USE WITH GA-566
65	D70K	BLACK DOOR
65	D70G	GOLD PLATED DOOR
65	D70SS	STAINLESS STEEL DOOR
66*	GD427-K	BLACK DOOR KIT c/w FACEPLATE
67*	W573-0007	10.3OZ TUBE HIGH TEMP SEALANT MILL PAC
68	GD799-KT	OLD TOWN RED BRICK KIT
68	GD804-KT	SANDSTONE BRICK KIT
68	GD805-KT	HERRINGBONE/SANDSTONE BRICK KIT
68	PRP70	PORCELAIN REFLECTIVE PANELS BRICK KIT

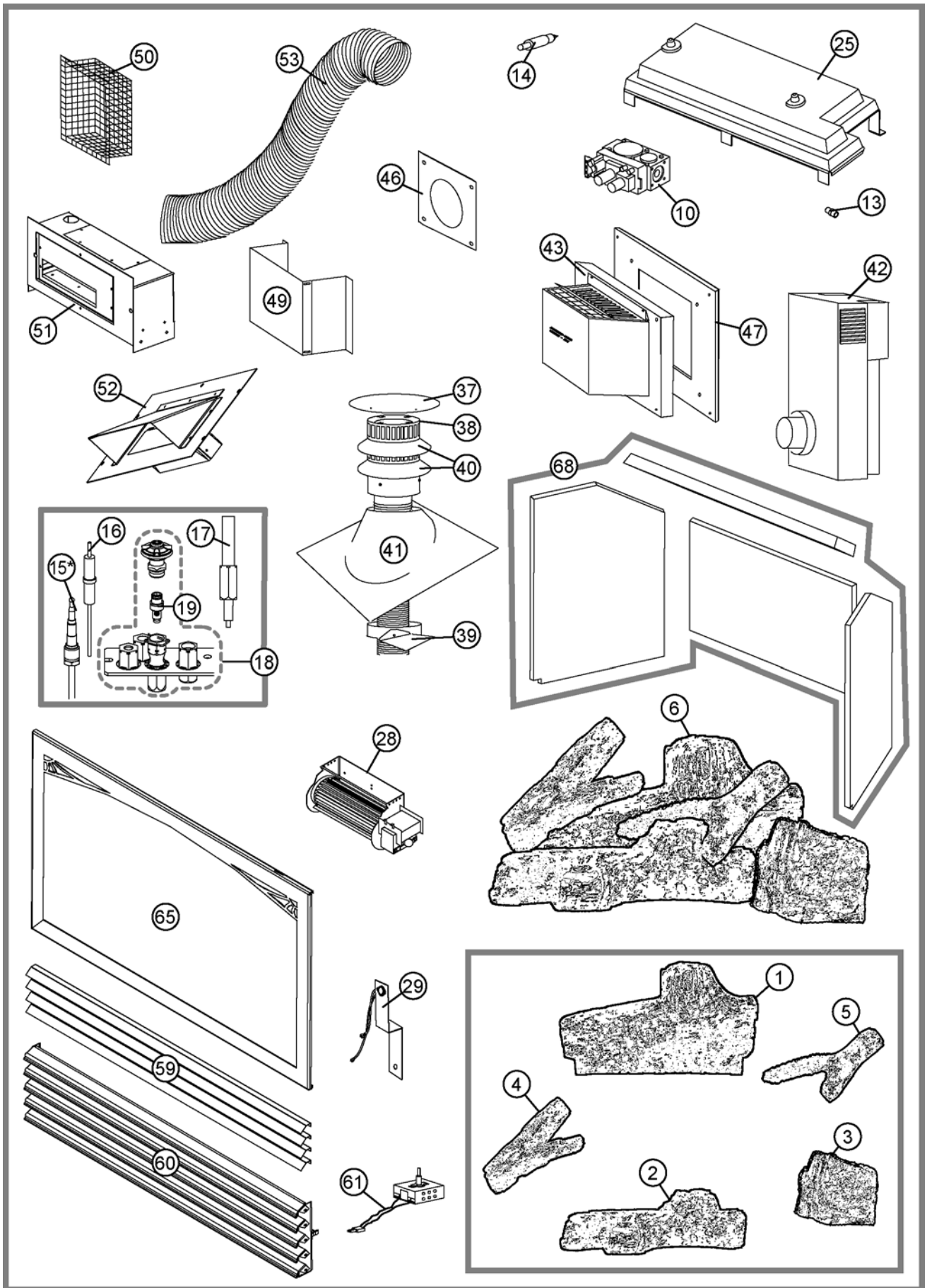



# TROUBLE SHOOTING GUIDE

BEFORE ATTEMPTING TO TROUBLESHOOT, PURGE YOUR UNIT AND INITIALLY LIGHT THE PILOT AND THE MAIN BURNER WITH THE GLASS DOOR OPEN.

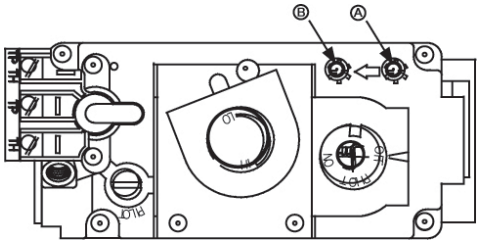
SYMPTOM	PROBLEM	TEST SOLUTION
Main burner flame is a blue, lazy, transparent flame.	Blockage in vent. Incorrect installation.	- remove blockage. In really cold conditions, ice buildup may occur on the terminal and should be removed as required. - refer to Figure 13 to ensure correct location of storm collars.
Flames are consistently too large or too small. Carboning occurs.	Unit is over-fired or under-fired.	- check pressure readings: Inlet pressure can be checked by turning screw (A) counter-clockwise 2 or 3 turns and then placing pressure gauge tubing over the test point. Gauge should read 7" (minimum 4.5") water column for natural gas or 13" (11" minimum) water column for propane. Check that main burner is operating on "HI". Outlet pressure can be checked the same as above using screw (B). Gauge should read 3.5" water column for natural gas or 10" water column for propane. Check that main burner is operating on "HI". <b>AFTER TAKING PRESSURE READINGS, BE SURE TO TURN SCREWS CLOCKWISE FIRMLY TO RESEAL. DO NOT OVERTORQUE.</b> Leak test with a soap and water solution.
		
Carbon is being deposited on glass, logs or combustion chamber surfaces.	Air shutter has become blocked Flame is impinging on the logs or combustion chamber.	- ensure air shutter opening is free of lint or other obstructions. - check that the logs are correctly positioned. - open air shutter to increase the primary air. - check the input rate: check the manifold pressure and orifice size as specified by the rating plate values. - check that the door gasketing is not broken or missing and that the seal is tight. - check that both 4" and 7" vent liners are free of holes and well sealed at all joints. - check that minimum rise per foot has been adhered to for any horizontal venting.
White / grey film forms.	Sulphur from fuel is being deposited on glass, logs or combustion chamber surfaces.	- clean the glass with a gas fireplace glass cleaner. <b>DO NOT CLEAN GLASS WHEN HOT.</b> If deposits are not cleaned off regularly, the glass may become permanently marked.
Exhaust fumes smelled in room, headaches.	Fireplace is spilling.	- check door seal and relief flap seal. - check for chimney blockage - check that the paint curing process is complete
Pilot goes out when the gas knob is released.	System is not correctly purged.	- purge the gas line with the glass door open.
<b>The gas valve has an interlock device which will not allow the pilot burner to be lit until the thermocouple has cooled. Allow approximately 60 seconds for the thermocouple to cool.</b>	Out of propane gas. Pilot flame is not large enough Pilot flame is not engulfing the thermocouple. Thermocouple shorting / faulty.	- fill the tank. - turn up the pilot flame. - gently twist the pilot head to improve the flame pattern around the thermocouple. - loosen and tighten thermocouple. - clean thermocouple and valve connection. - replace thermocouple. - replace valve.
	Faulty valve.	- replace.

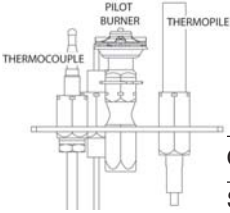
SYMPTOM	PROBLEM	TEST SOLUTION
Pilot burning; no gas to main burner; gas knob is on 'HI'; wall switch / thermostat is on.	Thermostat or switch is defective.	- connect a jumper wire across the wall switch terminals; if main burner lights, replace switch / thermostat.
	Wall switch wiring is defective.	- disconnect switch wires & connect a jumper wire across terminals 1 & 3; if the main burner lights, check the wires for defects and / or replace wires.
	Main burner orifice is plugged.	- remove stoppage in orifice.
	Faulty valve.	- replace.
Pilot goes out while standing; Main burner is in 'OFF' position.	Gas piping is undersized.	- turn on all gas appliances and see if pilot flame flutters, diminishes or extinguishes, especially when main burner ignites. Monitor appliance supply working pressure. - check if supply piping size is to code. Correct all undersized piping.
	Pilot will not light.	- check if pilot can be lit by a match - check that the wire is connected to the push button ignitor. - check if the push button ignitor needs tightening. - replace the wire if the wire insulation is broken or frayed. - replace the electrode if the ceramic insulator is cracked or broken. - replace the push button ignitor. - fill the tank.
	No spark at pilot burner	- check if pilot can be lit by a match - check that the wire is connected to the push button ignitor. - check if the push button ignitor needs tightening. - replace the wire if the wire insulation is broken or frayed. - replace the electrode if the ceramic insulator is cracked or broken. - replace the push button ignitor. - fill the tank.
	Out of propane gas	- replace the push button ignitor. - fill the tank.
	Spark gap is incorrect	- spark gap should be 0.150" to 0.175" (5/32" to 11/64" approx.) from the electrode tip and the pilot burner. To ensure proper electrode location, tighten securing nut (finger tight plus 1/4 turn).
	No gas at the pilot burner	- check that the manual valve is turned on. - check the pilot orifice for blockage. - replace the valve. - call the gas distributor.
Main burner goes out; pilot stays on.	Pilot flame is not large enough or not engulfing the thermopile	- turn up pilot flame. - replace pilot assembly.
	Thermopile shorting	- clean thermopile connection to the valve. Reconnect. - replace thermopile / valve.
	Remote wall switch wire is too long; too much resistance in the system.	- shorten wire to correct length or wire gauge.
	Faulty thermostat or switch.	- replace.
	Refer to "MAIN BURNER GOES OUT; PILOT STAYS ON"	
Main burner goes out; pilot goes out.	Vent is blocked	- check for vent blockage.
	Vent is re-circulating	- check joint seals and installation.
	4" flexible vent has become disconnected from fireplace.	- re-attach to fireplace.
Remote wall switch is in "OFF" position; main burner comes on when gas knob is turned to "ON" position.	Wall switch is mounted upside down	- reverse.
	Remote wall switch is grounding.	- replace.
	Remote wall switch wire is grounding.	- check for ground (short); repair ground or replace wire.
	Faulty valve.	- replace.

## Wolf Steel Fireplace Service History

This fireplace must be serviced annually depending on usage.

Date	Dealer Name	Service Technician Name	Service Performed	Special Concerns

