

Warranty and Service Information

For Warranty and Product support contact Authorized
SANYO DISTRIBUTOR

Alcom Electronics Pte Ltd - Singapore

Phone: (65) 68412668

Fax: (65) 68412628

Alcom Communications Sdn Bhd - Malaysia

Phone: (60) 3 7803 7676

Fax: (60) 3 7803 0660

Email: support@alcom.com.sg

Website: www.alcomonline.com

Due to continuous product development all features and specifications are subject to change without prior notice.

USER'S MANUAL

Caller ID Phone

MODEL NO. TEL-2095

SANYO



MAIN DIAGRAM

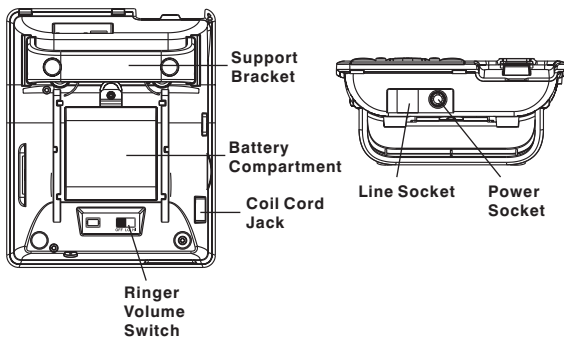
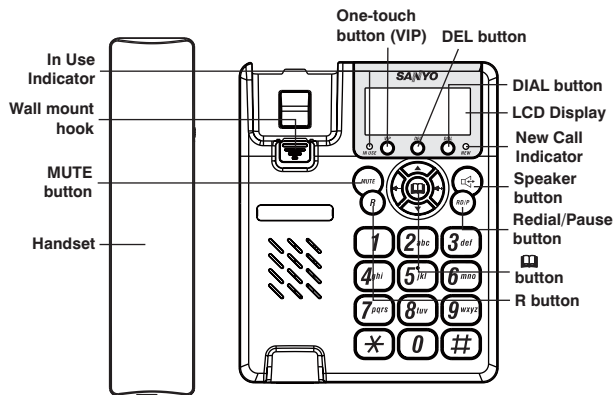

TROUBLESHOOTING

If you have problems with your phone, please check below for helpful hints:

- BLANK OR FAINT SCREEN**
 - Check the line cord. Connect the telephone cord. Check batteries, Check adaptor.
- CALLER ID WILL NOT WORK PROPERLY**
 - Call your telephone company to verify that your Caller ID services are active.
- PHONE WILL NOT RING**
 - You may have too many communication devices hooked to a single line. A communication device can be a phone, modem or facsimile (FAX) machine. Contact your telephone company for help in calculating the limit for your residence or business line.
- NO DIAL TONE**
 - Verify that the line cord is plugged in correctly.
 - Verify that the line cord connection is correct and tightly secured.
- NO DATA SENT**
 - Call your telephone company to verify that your caller ID services are active.
 - If you have an answering machine connected to this Phone, ensure that your answering machine is set to answer after at least two rings.
 - You answer the call before two rings.
 - Contact your telephone company if the problem continues for more than 24 hours. The telephone company may be experiencing temporary disconnection.
- NO RESPONSE ON LCD DISPLAY**
 - If you have experienced a power failure when using optional AC adaptor, the batteries for memory back up could become weak or dead. If the power is restored and the display screen does not respond then You must replace the batteries with new ones.

● **Using the call back feature** (NOTE: If the number is blocked or is not available, it can not be called back.)

A. Call back the outgoing number: The unit can store up to 10 outgoing numbers.

1. In the on-hook state, press the **DIAL** button once, the last dialled number will show on the LCD, then use the ▲ or ▼ button to select the number that you want to dial out.

2. Pick up the handset or press the  button, the phone number can be dialled out automatically.

B. Call back the incoming number: The unit can store minimum 76 incoming numbers.

1. Lift the handset or press the  button to get a dial tone.

2. Select the caller that you want to call back by pressing the ▲ or ▼ button.

3. Press the **DIAL** button to automatically dial the phone number.

Or

In the on-hook state, use the ▲ or ▼ button to select the call you want to call back, then pick up the handset or press the  button, the phone number can be dialled out automatically.

TABLE OF CONTENTS

FEATURE LIST	1
SAFETY INSTRUCTIONS	2
INTRODUCTION	3
FUNCTION BUTTONS	4
FUNCTION OPERATIONS	7
RECEIVING CALL RECORDS	12
REVIEWING DISPLAY MESSAGES	12
MESSAGE WAITING	
TOTAL & NEW CALLS	
PRIVATE	
REPEAT CALLS	
END OF LIST	
OUT OF AREA	
BATTERY LOW INDICATOR	
CALLER ID SYSTEM OPERATIONS	14
TROUBLESHOOTING	16

FEATURE LIST

1. FSK standard caller ID system
2. Stores minimum 76 incoming calls number, date & time
3. Stores up to 10 outgoing calls number
4. Stores up to 70 names & numbers in phone book
5. LCD displays calling number
6. Call back function
7. Delete individual or all records
8. Real time clock (Set time)
9. New call indicator
10. Area & long distance code setting
11. Languages selection
12. Message waiting function
13. LCD contrast selection
14. Last number redial
15. Speakerphone
16. One-touch memory (VIP)
17. Flash, Pause, Mute
18. Timer

CALLER ID SYSTEM OPERATIONS

Subscription to Caller ID service from your local phone company is required before the first use.

● **New call indicator** - The red indicator light of your phone will flash to indicate that you have new calls until all the new calls have been reviewed.

● **Review your call records** - Use the ▲ or ▼ button to scroll through the caller display list. If the incoming telephone number is longer than 13 digits, an arrow will show in the right corner of the LCD display. Use ▲ or ▼ button once to review the other digits, use ▲ or ▼ button again to move on to the next record. At the end of the caller display list, you will see the **END OF LIST** message. Press the ▲ or ▼ button to continue.

● **Save call records** - Save specific calls by deleting old or unnecessary call records.

NOTE: Your phone stores minimum 76 call records before the memory becomes full. When the next call comes in, the oldest record automatically drops off to make room for the new call record.

● **DEL single or all record number(s)** - In the on-hook state, use the ▲ or ▼ button to select the number which you want to remove, press the **DEL** button, the LCD will show **DEL?** and then press the **DEL** button again to remove this number, press other button to exit. If you press the **DEL** button for about 6 seconds, the LCD will show **ALL DEL?** and press the **DEL** button to remove all numbers and the LCD will show **NO CALL**.

TOTAL & NEW CALLS - This shows you the total and new calls to be reviewed. In this example, you have 4 calls in total which include 2 new calls and it is MONDAY.

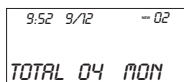

9:52 9/12 -- 02
TOTAL 04 MON

PRIVATE - If the caller has exercised the option to prevent his name and number from being sent, **PRIVATE** will show on the screen.

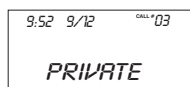

9:52 9/12 CALL 03
PRIVATE

REPEAT CALLS - If a call comes repeatedly, the display will show **REPEAT** icon in the upper right corner of the LCD.

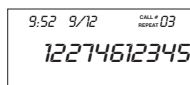

9:52 9/12 CALL 03
REPEAT 03
12274612345

END OF LIST - This message displays when reaching the top (end) of the call history list by using the ▲ or ▼ button. If there is no call, then LCD shows **NO CALL**.

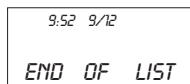

9:52 9/12
END OF LIST

OUT OF AREA - This message will display when some one calls from an area where the telephone company is not offering the caller identification services or is not yet providing number delivery to your area via the long distance network.

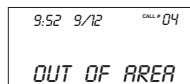

9:52 9/12 CALL 04
OUT OF AREA

BATTERY LOW INDICATOR: If the battery is low, the battery low icon  will appear and flash.

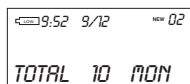

 9:52 9/12 MAX 02
TOTAL 10 MON

SAFETY INSTRUCTIONS

To reduce the risk of fire, electrical shock, and injury, please follow these basic safety precautions before you use this equipment.

1. Carefully read the instructions in this manual.
2. Follow all warnings and instructions marked on the unit.
3. When cleaning, unplug the telephone jack from the wall outlet. Use a damp cloth. Do not use liquid or aerosol cleaners.
4. Do not use this equipment near water e.g.: near a kitchen sink, bathtub, washbowl, laundry tub, swimming pool or in a wet basement.
5. Install in a protected location. Ensure all lines and cords are away from foot traffic. Do not place objects on the line cord that may cause damage or abrasion.
6. Avoid spilling any liquid on the unit. This may cause internal shorting, fire or shock. Otherwise, the phone is not covered under your warranty.
7. Do not overload wall outlets and extension cords as this can result in the risk of fire or electrical shock.
8. Never push objects of any kind into this telephone as they can touch dangerous voltage points or short out parts that could result in a risk of fire or electrical shock.
9. Take the phone to a qualified technician when it requires repair work or service. To reduce the risk of electrical shock, do not disassemble the telephone. Opening or removing covers can expose you to dangerous voltages or other risks. Incorrect re-assembly can cause electrical shock during subsequent use.
10. Avoid using the telephone during an electrical storm. There can be a slight risk of electrical shock from lightning.
11. Do not use the telephone to report a gas leak, if in the vicinity of the leak.
12. Unplug this telephone from the wall outlet and refer servicing to qualified service personnel under the following conditions:
 - If liquid is spilled into the unit.
 - If the unit is exposed to rain or water.
 - If the unit does not operate normally by following the operating instructions.
 - If the unit is dropped or the casing is damaged.
 - If the unit exhibits a distinct change in performance.

INTRODUCTION

CHECK THE CONTENTS OF THE BOX

Box should contain:

- Handset with handset cord and phone base
- Four 1.5V AA size batteries
- Support bracket
- Telephone line cord
- User's manual
- Warranty card

BATTERY INSTALLATION

The Caller ID phone requires four 1.5V AA size batteries for LCD display.

1. Remove the battery cover from the back of your Caller ID phone
2. Insert four AA size 1.5V batteries by observing the +/- polarity marked in the compartment.
3. Replace battery compartment cover.

NOTE: You can also insert adapter for LCD display (optional).

CONNECTING LINE CORDS

Plug one end of the supplied modular cord into the line jack. Then plug the other end into telephone line jack.

RECEIVING CALL RECORDS

A caller ID record consists of the following information:

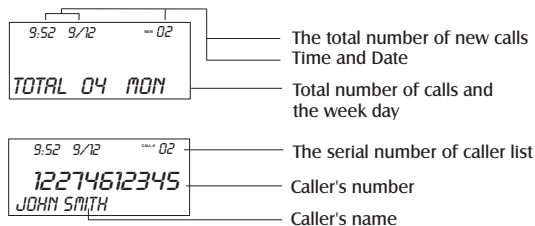

REVIEWING DISPLAY MESSAGES

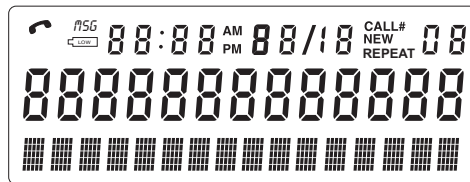

MESSAGE WAITING - If you have voice mail service from your telephone company and a recorded message is left, the screen will display **MESSAGE WAITING**. The **MSG** will appear in the upper left corner. The icon will remain until you have retrieved your voice mail and the **MESSAGE WAITING** will be saved as a call.

***NOTE: This function should be supported by your telephone company.**

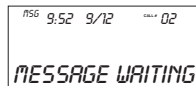

7. HOUR FORMAT SELECTING

Press the **DIAL** button to enter this setting when the LCD shows **HOUR FORMAT** and then the current value will display.

Use the **▲** or **▼** button to select the hour format (12 HOUR/24 HOUR). Press the **DIAL** button to confirm and exit.

8. DATE FORMAT SELECTING

Press the **DIAL** button to enter this setting when the LCD shows **DATE FORMAT** and then the current value will display.

Use the **▲** or **▼** button to select the date format (DD-MM/MM-DD). Press the **DIAL** button to confirm and exit.

In the DD-MM mode, the time display sequence is day-month and in the MM-DD mode, the sequence is month-day.

FUNCTION BUTTONS

1. Ringer Volume Selection

Set the ringer volume switch to the desired position (HI/LO/OFF). To have the maximum ringer volume, move the ringer volume switch to the **HI** position. To have a low ringer volume, move the ringer volume switch to the **LO** position. If you would prefer the ringer not to disturb you, move the ringer volume switch to the **OFF** position.

2. Receiver and Speaker Volume Adjustment

There are 4 levels for selection. When your phone is in use mode, you can press the **🔊+** or **🔊-** button to adjust the receiver and speaker volume, and the corresponding level will show on the LCD.

3. Redial Function

Lift the handset or press the **📞** button, then press the **RD/P** button to redial the last dialed number.

4. Speaker Function

To switch your call to speaker phone, press the **📞** button and replace the handset in the cradle. To switch back, simply lift the handset and speak as normal. In the speaker state, you can make or answer a call.

5. Flash Button

Press the **R** button to terminate a call and institute a dialling tone for another call or to get another call from "Call Waiting" (a special telephone service).

*NOTE: If you do not have any special telephone service, such as Call Waiting, pressing **R** button during a call may disconnect your current conversation.*

In the on-hook state, press and hold the **R** button to enter the **TIME SETTING**. (Refer to "FUNCTION OPERATIONS", section "TIME SETTING" for details).

6. Pause Function

Allows you to insert a temporary pause during dialling sequence. For example, dialling an international number (e.g.: 011-886-22-795-1234), some telephone company systems will not register the entire number entry without a pause between the prefix numbers. You may have to dial 011- **RD/P** dial 886 - **RD/P**. This allows adequate timing for the phone number to register with the telephone company's system and complete the call.

7. Mute Function

If you wish to speak privately to someone else in the room without your caller overhearing, just press the **MUTE** button once and the LCD will display **MUTE**. To resume normal conversation, just press the **MUTE** button once again.

8. DEL Button

When the number you want to remove displayed on the LCD, press the **DEL** button, the LCD will show "**DEL?**", press the **DEL** button again to remove this number.

When your Caller ID phone is in use mode, you can press the **DEL** button once to stop the timer, press it once more to restart it. Also the timer can start after dialling out the call about 10 seconds and stop when hanging up.

9. Phonebook Button

Press the **☰** button to enter the phone book directly. Refer to "**FUNCTION OPERATIONS**", section "**PHONE BOOK**".

4. LANGUAGES SELECTING

The unit support multi languages, including *English1, Greek, Australian, Czech, Slovak, Turkish, English2, Spanish, Dutch, French, German, Polish, Swedish, Danish, Finnish and Norwegian.*

Press the **DIAL** button when the LCD shows **SET LANGUAGE** to enter the language setting. Use **▲** or **▼** button to select the language. Press the **DIAL** button to confirm and exit.

5. AREA & LONG DISTANCE CODE SETTING

(Only under "English1", "English2", "Greek", "Austral", "Czech", "Slovak" and "Turkish" language and in on-hook state, the setting can be done.) When you use this phone for the first time, or move to an area that has different area code, you must enter your area code. This is necessary because the phone must distinguish local or long distance calls to properly dial calls from the Caller ID list.

1. Press the **DIAL** button when the LCD shows **SET AREA & LDS** to enter the setting.
2. Press **▲** or **▼** button to select the correct digit.
3. Press the **DIAL** button to confirm and enter the next digit setting.
4. When the area code setting has been completed, press the **DIAL** button to confirm and the LCD displays **SET LDS CODE**. The unit enters the long distance code setting.
5. Repeat the step 2~3 to finish the setting for LDS code and press the **DEL** button to exit.



6. FLASHING TIME SETTING

Press the **DIAL** button to enter this setting when the LCD shows **SET FLASH** and then the current value will display. Use the **▲** or **▼** button to set the flash time (100ms/120ms/300ms/600ms). Press the **DIAL** button to confirm and exit.

e. To delete a single number in the phone book:

During the reviewing process, use ▲ or ▼ button to select the number you want to delete, press the **DEL** button once, the LCD shows **DEL?**. Press the **DEL** button again to delete it.

f. To copy the Caller ID numbers and last 10 dialled numbers to phonebook

When the LCD shows the CID or last 10 dialled number, press and hold the  button about 3 seconds to add the number to phonebook. The first character of the name will flash to indicate you can modify it, then press the  button to confirm and enter the next new number adding, press the **DEL** button to exit.

2. LCD CONTRAST SETTING

Press the **DIAL** button to enter the LCD contrast setting when the LCD shows **LCD CONTRAST**, then the current contrast level (**HI/LO**) will show on the LCD. Press ▲ or ▼ button to make a selection, press the **DIAL** button to confirm and exit.

3. TIME SETTING

Press the **DIAL** button when the LCD shows **SET TIME**, use ▲ or ▼ button to select the correct number. Press the **DIAL** button to confirm and move to the next digit, press the **DEL** button to exit.

NOTES:

1. When you receive a first call to this unit, time and date will be set automatically if you have Caller ID service (FSK standard).
The setting sequence is *hour - minute - month - day - year - week*.
2. After the *year* setting, the cursor for *week* will flash, you can use ▲ or ▼ button to activate/deactivate this setting. If it is activated, the *week* will set automatically, or instead of showing the week day, the LCD will only show the **TOTAL CALLS XX** in the standby state.
3. You need to select the *year* to ensure the week displays correctly.

10. One-touch Memory

a. To store a number to VIP button

You can store a number to the one-touch memory in on-hook state.

1. Enter the telephone number you want to store.
2. Press and hold the **VIP** button until the LCD shows **SAVE OK**.

b. To dial the number from one-touch memory

1. Lift the handset or press the  button.
2. Press the **VIP** button to dial out the matching number.

c. To review the number in one-touch memory

In the on-hook state, press the **VIP** button, the matching stored number will show on the LCD.

FUNCTION OPERATIONS

This unit contains the following special functions, press the **DEL** button **twice** to enter the setting mode and press **▲** or **▼** button to select one. The setting sequence is *PHONE BOOK - LCD CONTRAST - SET TIME - SET LANGUAGE - SET AREA& LDS - SET FLASH - HOUR FORMAT - DATE FORMAT*. Press the **DIAL** button to confirm or press the **DEL** to exit.

1. PHONE BOOK

a. To add number and name to the phone book

Key	Characters	Key	Characters
1	1 . , ? ! - ' ()	6	M N O m n o 6 Ö Ø Ñ
2	A B C a b c 2 Ä Å Æ	7	P Q R S p q r s 7
3	D E F d e f 3	8	T U V t u v 8 Ü
4	G H I g h i 4	9	W X Y Z w x y z 9
5	J K L j k l 5	0	0 + & @ / \$ %

- Press the **DIAL** button to select the phonebook menu and the LCD will show: **REVIEW >>**. Press **▲** or **▼** to select the **ADD >>** menu. Press the **DIAL** button to enter the function of adding name and number. (You can enter it directly by pressing and holding the **☎** button.)
- Enter the telephone number by keypad. Press the **DEL** button to delete the previous digit. The maximum number of digits to be entered is **20**, if the number exceeds **20**, the LCD will show **TOO LONG** and the exceeding digits will not be stored.
- After finishing the number setting, press and hold the **DIAL** button (or press the **☎** button) to enter the name setting, press the appropriate keypad to get the following characters. If the next character is on the same button as the previous one, you should first press the **DIAL** button before the entering. Press **DEL** button to delete the previous character if necessary.

4. When the setting is completed, press and hold the **DIAL** button (or press the **☎** button once) to store the records and meanwhile enter the next number presetting.

b. To review the number/name in phone book

1. Press the **DIAL** button to select the phonebook menu and the LCD will show **REVIEW >>**. Press the **DIAL** button to enter the function of reviewing the name and number. (Also you can press the **☎** button once, then the last record in the phone book will show on the LCD.)

Use **▲** or **▼** button to review. You can also quickly review the call by the first letter of the name, when press the first letter of the name, the LCD will display the matching name(s), then use **▲** or **▼** button to get the right one.

2. In the on-hook state, press sequence of the number+# to review. e.g.: If you want to review the seventh number, just press 7#, the LCD will show the seventh number and name. In this state, you can continue review the other numbers by pressing **▲** or **▼** button.

NOTE: If the number is longer than 13 digits, an arrow will show on the bottom right of LCD, press **▲** or **▼** button to review the other digits, press **▲** or **▼** button again to move on to the next record.

c. To speed dial the number from the phone book

During the reviewing process, use **▲** or **▼** button to select the number you want, when it shows on the LCD, pick up the handset or press the **☎** button to dial it out.

d. To modify phone book name

During the reviewing process, use **▲** or **▼** button to select the number you want. When it shows on the LCD, press and hold the **☎** button for about 3 seconds, then the first character of the name will flash to indicate you enter the function of name modification.